

おりがみはうす ガレージブックシリーズ 7

西川誠司 作品集

Works of
Seiji Nishikawa

西川誠司・著

山口真・編 立石浩一・英訳

Model Designer : Seiji Nishikawa

Editor : Makoto Yamaguchi

Translator : Koichi Tateishi



ドラゴン / Dragon (P.28)



魔女 / Witch (P.10)



マーメイド / Mermaid (P.16)



鳥獣戯画の蛙 / A Frog in "Chouju Giga (Frolicking Birds and Animals)" (P.44)



ペガサス / Pegasus (P.21)



カニ / Crab (P.142)

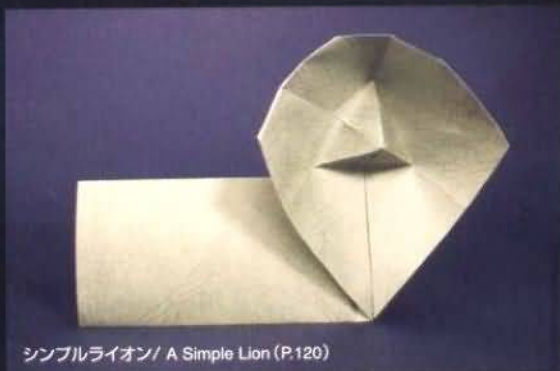

シンプルライオン / A Simple Lion (P.120)



岩の上の鷹 / A Hawk on a Rock (P.122)



トラ / Tiger (P.99)

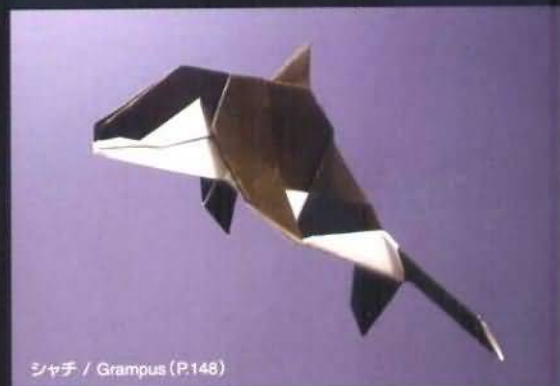

シャチ / Grampus (P.148)



ライオン / Lion (P.78)



キリン / Giraffe (P.72)



縞のあるトラ / Tiger (with Stripes) (P.115)



始祖鳥 / Archaeopteryx (P.132)



ピエロ(フリルバージョン) / Clown (A Frilled Version) (P.178)



馬 / Horse (P.108)



ピエロ(帽子バージョン) / Clown (A Hatted Version) (P.178)



シェパード / Shepherd (P.85)



セキレイ / Wagtail (P.126)



プードル / Poodle (P.90)



はくちょう座 / Cygnus (P.169)



わし座 / Aquila (P.167)



こと座 / Lyra (P.171)



さそり座 /
Scorpius (P.174)



スペースシャトル / Space Shuttle (P.151)



天体望遠鏡 / Telescope (P.157)



星の短冊 / A Strip of Paper with a Star (P.176)



天狗 / Tengu (A Japanese Legendary Mountain Goblin) (P.186)

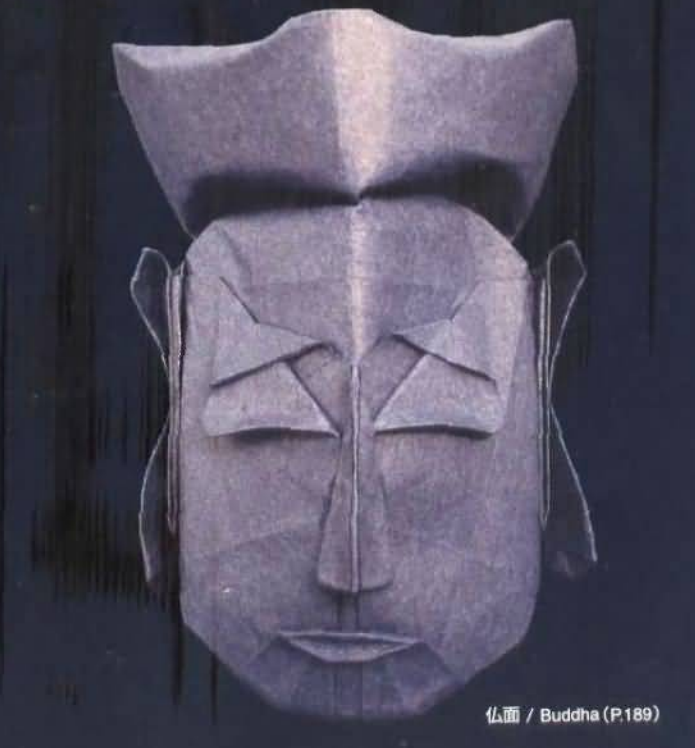

仏面 / Buddha (P.189)

まえがき Foreword

本書に収載した作品はその創作年が1977年から1998年と20年以上にわたっています。この約20年間というのは、私にとって折り紙を通じて本当にかげがえのない体験を重ねた充実した年月です。この間に作品に何らかの進歩が見受けられるかどうかは別にして、こうしてあらためて気に入った作品を眺めてみるとそれぞれに思い出があって感慨無量です。作品は動物、空想上の生き物、宇宙などのテーマを中心に選んでいます。おりがみはうす刊の「折紙図鑑・昆虫I」（川畑文昭・西川誠司共著）の昆虫作品と併せて楽しんでいただけると幸いです。

ところで、自作を眺めて大きく2つの傾向に気がつきました。ひとつはインサイドアウト作品が多いことです。表裏を上手く活用することに関心を向けるこの技法は、近代折り紙の重要な特徴ではないでしょうか。この技法なしに作品作りがほとんど成立しない自分を再認識しました。もう一つは折り出しの感覚を重視している点です。本書に収載のカニ、キリン、ライオン、パンダ（胴体）など、折り出しの非常に早い段階の形に魅力を感じて折り進めていたことをハッキリと思い出すことが出来ます。

折り紙の魅力にとりつかれてからすでに30年以上の月日を数えますが、自分の作品だけで一冊の本を作ることが出来るとは、考えてみれば何という幸運でしょう。紙を手にしてあれこれ折って何か新しい形を作ってみることと、それを折り図（しかも多くの人が十分再現可能なステップに細分化して）に仕上げるの間には大きな隔たりがあります。作品と折り図が有っても、それを出版物に出来るかどうかということにも大変な隔たりがあります。本書は、作品：西川誠司、作図：おりがみはうす、編集：山口真さん、というように、本作りの一番大変なところを、山口真さんとおりがみはうすのスタッフの皆さんの尽力に依っています。本書の制作を決断下さった山口さんをはじめ、折図、校正、英訳など制作にご協力戴いた方々には、感謝の言葉も見つかりません。そして、本書を手にしていただいた折り紙ファンの皆さんにも心から感謝いたします。

This book contains origami works I created in twenty-two years (1977-1998). This period represents my full life as an origami artist. All models bring me some good memories, so they are like a part of myself. Among works in that period, insects were already published in *Origami Insects* (co-authored by Fumiaki Kawahata and Seiji Nishikawa, Origami House), so this book and the insect book are complementary to each other.

From the creator's point of view, works in this book are notable in two points. First, so many inside-out works are included. The inside-out method using a sheet of paper colored differently on the two sides is one of the significant characteristics of modern origami. I myself would have a hard time if I did not use the inside-out method. Secondly, the flavor of my works are revealed in the very early steps of folding. For example, the basic skeletal shapes of many works (like *Crab*, *Giraffe*, *Lion*, and *Panda*) can be already grasped after only a few steps at the beginning. Perhaps the early steps and outputs are one of the most attractive parts of creation of origami works for me.

This is the first book which contains only origami works of mine. However, creating a book cannot in any sense be my sole work. The staff members of the Gallery Origami House, especially Mr. Makoto Yamaguchi who took responsibility of all the editorial work, did a marvelous job of putting my works into one printed book. I would like to express my gratitude to them first of all. It is also true that a book of this kind cannot be possible without origami enthusiasts all over the world, so I would like to thank them as well.

西川 誠司
Seiji Nishikawa

目次 Contents

はじめに Foreword	5
折り図記号の凡例 Symbols for Folding	7
基本形／沈め折り Preliminary Bases and Sink	8

第1章 ファンタジー Fantasy

魔女 Witch	10
マーメイド Mermaid	16
ペガサス Pegasus	21
ドラゴン Dragon	28
鳥獣戯画の蛙 A Frog in "Choju Giga (Frolicking Birds and Animals)"	44

第2章 動物 Animals

ウサギ Rabbit	55
カンガルー Kangaroo	59
パンダ Panda	66
キリン Giraffe	72
ライオン Lion	78
シェパード Shepherd	85
プードル Poodle	90
トラ Tiger	99
馬 Horse	108
縞のあるトラ Tiger (with Stripes)	115
シンプルライオン A Simple Lion	120
岩の上の鷹 A Hawk on a Rock	122
セキレイ Wagtail	126
始祖鳥 Archaeopteryx	132
カニ Crab	142
シャチ Grampus	148

第3章 宇宙 The Universe

スペースシャトル Space Shuttle	151
天体望遠鏡 Telescope	157
わし座・はくちょう座・こと座・さそり座 Aquila, Cygnus, Lyra, Scorpius	167
星の短冊 A Strip of Paper with a Star	176

第4章 面 Mask

ピエロ(フリルバージョン／帽子バージョン) Clown (A Frilled Version / A Hatted Version)	178
天狗 Tengu (A Japanese Legendary Mountain Goblin)	186
仏面 Buddha	189

折り図記号 Symbols for Folding

折り線の種類 Types of crease lines

谷折り線 Valley fold

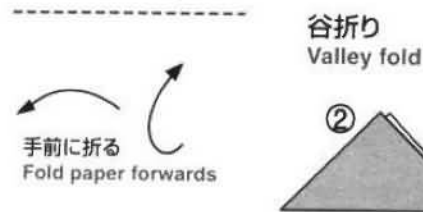

山折り線 Mountain fold

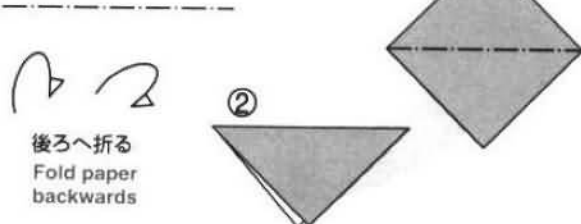

折り方の技法 Basic Folding Skills

中わり折り Inside-reverse fold

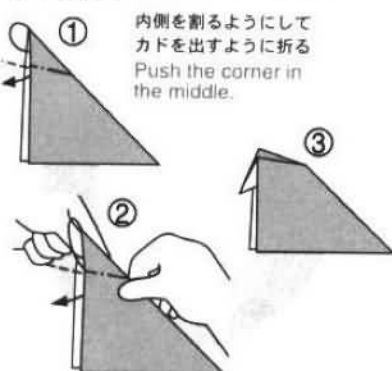

かぶせ折り Outside-reverse fold

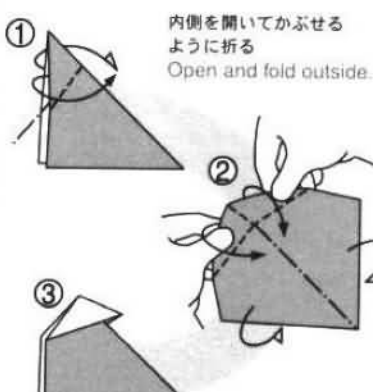

内側をひろげてつぶすように折る Squash fold

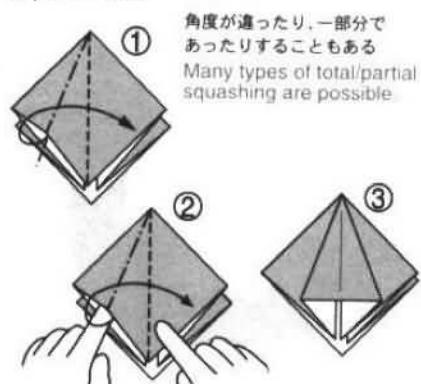

いろいろな記号 Symbols

折り筋をつける Making a crease line

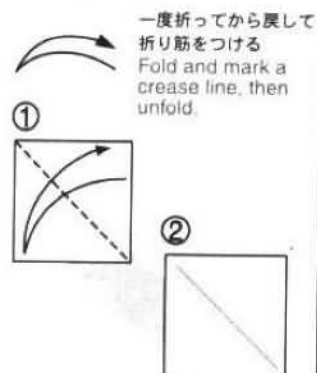

裏返す Turn paper over

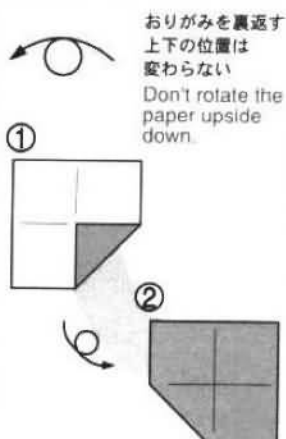

段折り Pleat fold

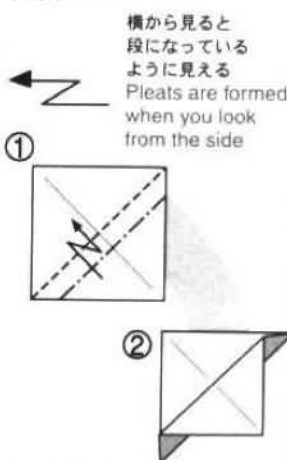

下の部分を出すように折る Release bottom flap when making a fold

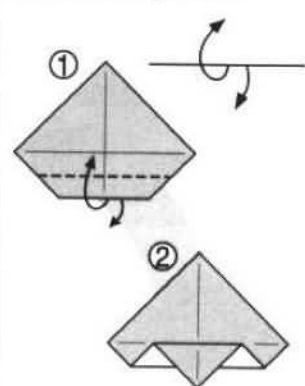

次の図が大きくなる A magnified view

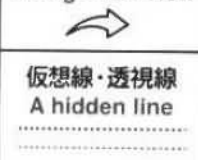

ひろげる Open up



次の図の見る位置が変わる Paper position changes (rotation)

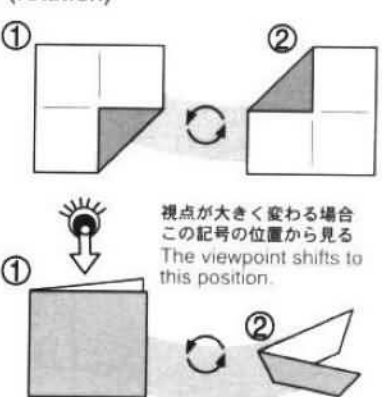

等分記号 Division

長さの等分 Dividing the length

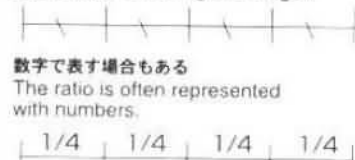

角度の等分 Dividing the angle

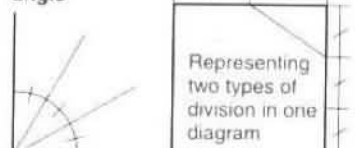

押す・つぶす Push paper in



巻くように折る Roll the flap by repeated folds

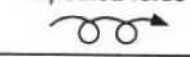

引き出す Pull out



注意するところ Marked points

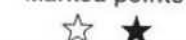

基本形 / 沈め折り Preliminary Bases and Sink

基本形 Preliminary bases

風船基本形 Water Bomb Base

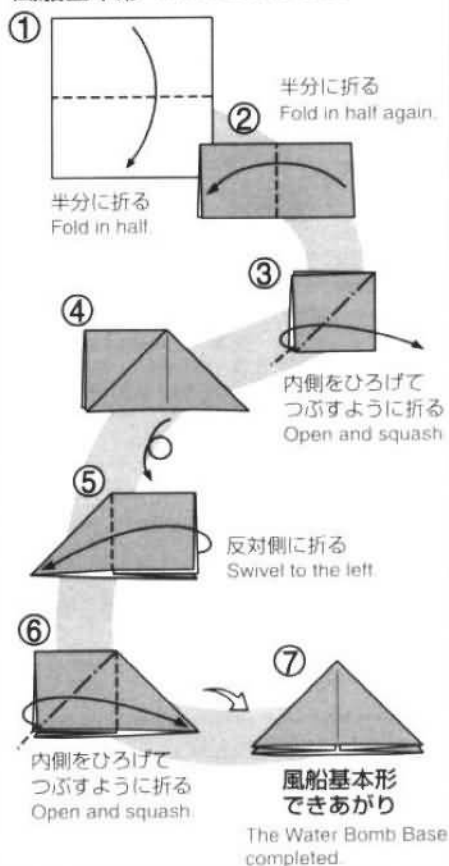

正方基本形と鶴の基本形 Preliminary Base / Bird Base

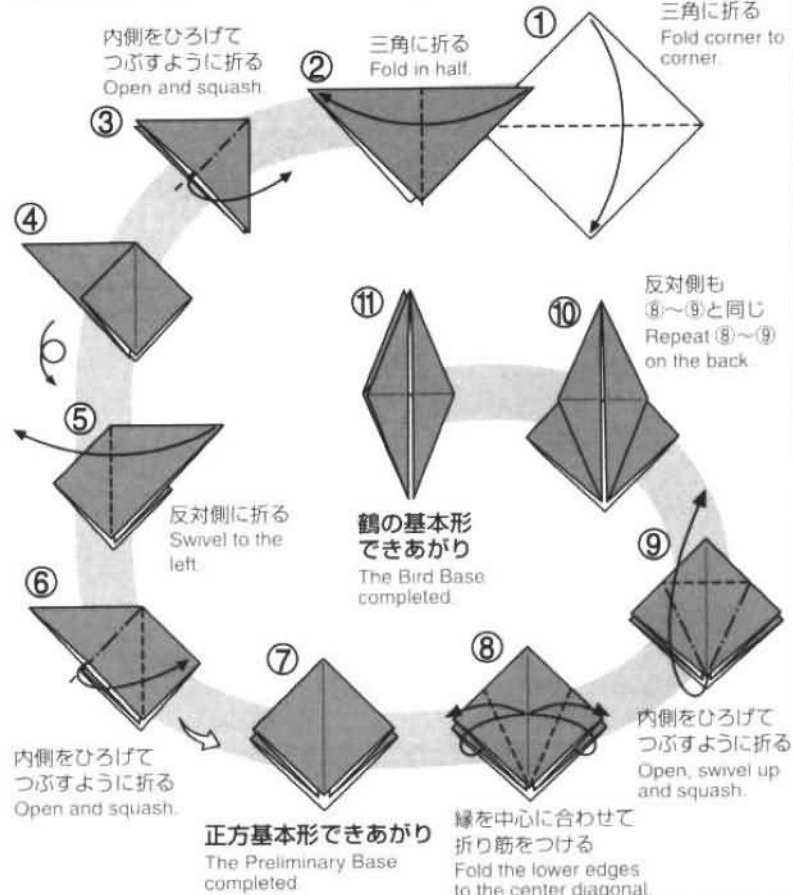

沈め折り Open sink / Closed sink

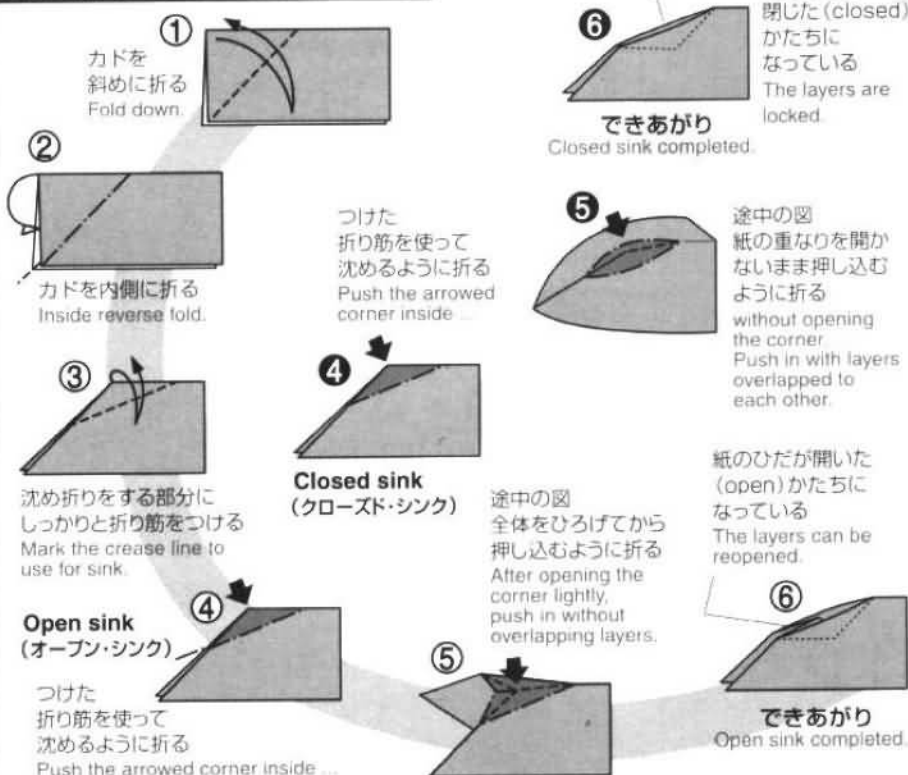

ひだの形によってはclosed sink
にしかできない場合もあります
Certain complexes of layers allows
only for closed sink.

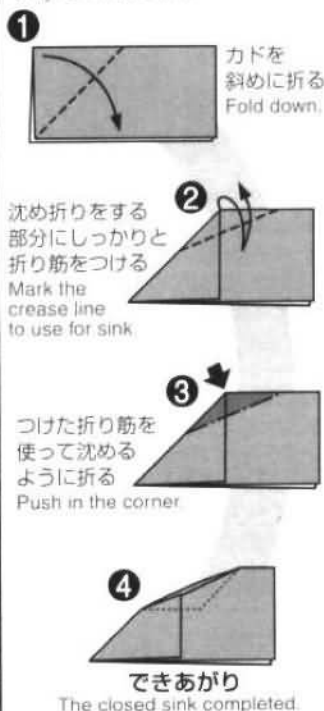

西川誠司作品集

西川誠司 著

山口 真 編 / 立石浩 · 英訳



Works of Seiji Nishikawa

Model Designer : Seiji Nishikawa

Editor : Makoto Yamaguchi

Translator : Koichi Tateishi

魔女

Witch

大きな袖をデザインの特徴にしました。鷲鼻を作れば、自然と“魔女顔”となりますが、ちょっと凝って顎を分離させたのが顔のシルエットをはっきりさせる大事なポイントになっていると思います。杖など持たせると更にそれらしくなります。

The wide sleeves and the detached jaw, not speaking of the hooked nose, make this work witchlike. Let her hold a staff for a better result.



Created 1991 Paper 不切正方一枚折り: 1 piece

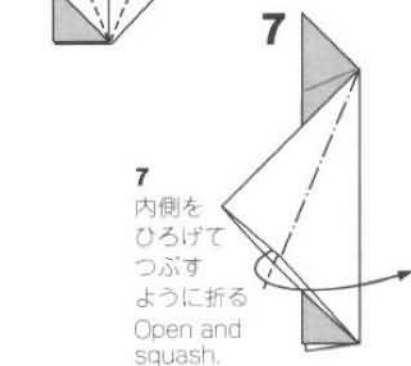
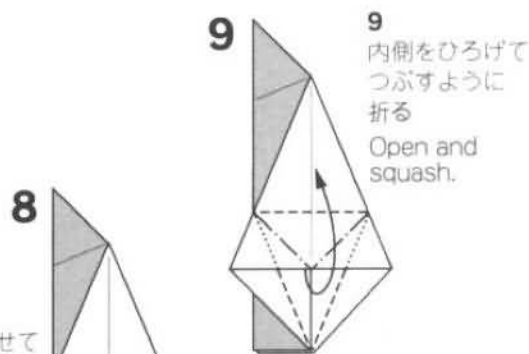
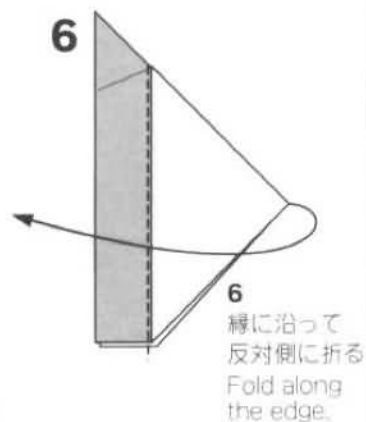
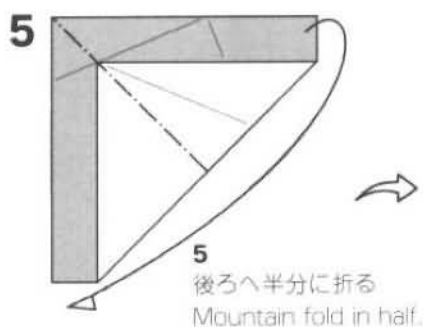
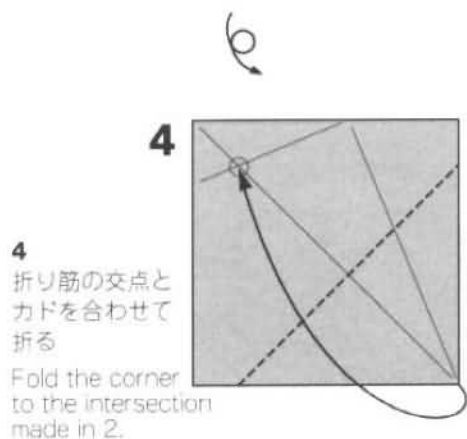
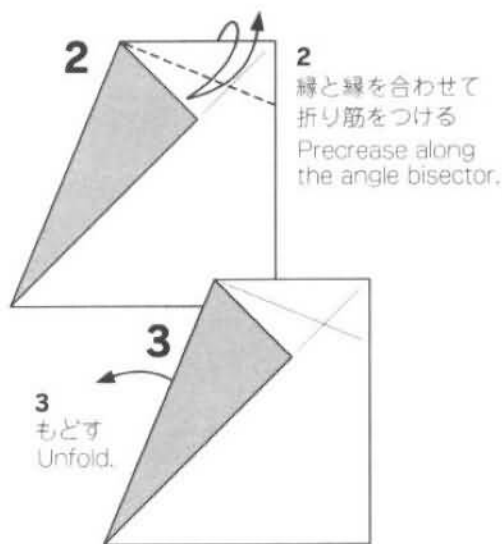
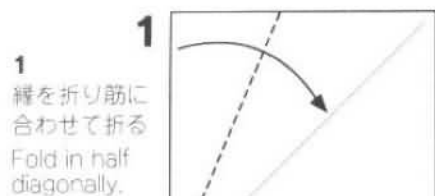

11
内側をひろげて
つぶすように折る
Open and squash.

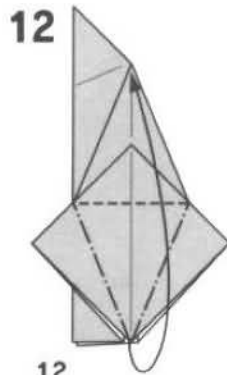
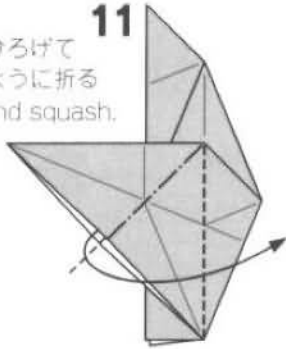

12
ついている折り筋で
内側をひろげて
つぶすように折る
Swivel along
the precrease.

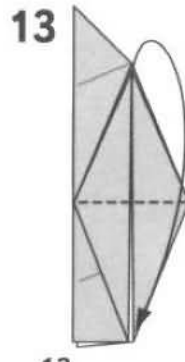

13
カドを下に折る
Fold down.

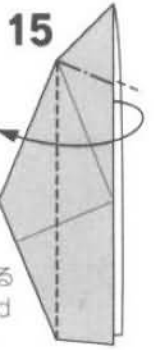
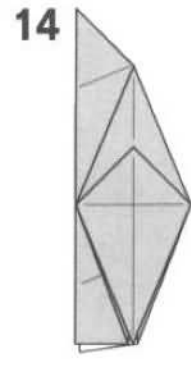

15
内側を
ひろげて
つぶす
ように折る
Open and
squash.

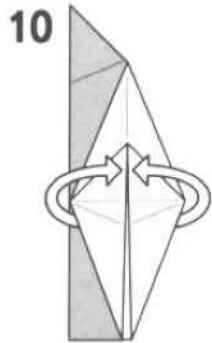

10
紙の裏が
出ている部分を
はがすようにして
ひろげる
Detach the white
layer from the
inner layer.

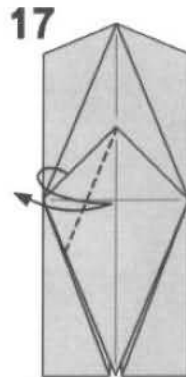

17
線を中心に合わせ
て折り筋をつける
Fold along the
angle bisector.

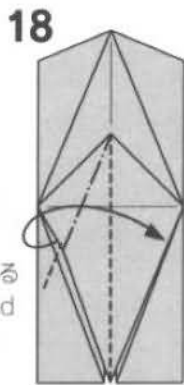

18
内側を
ひろげて
つぶす
ように折る
Open and
squash.

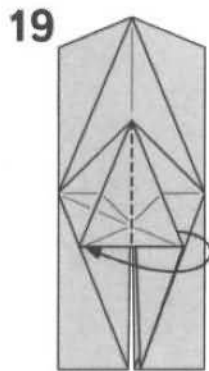

19
カドを反対側に折る
Fold one layer to the left.

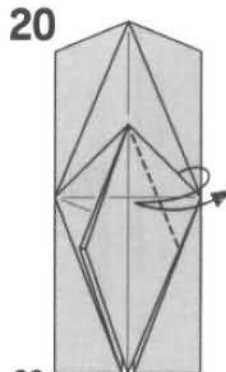

20
反対側も17~19と同じ
Repeat 17~19 on
the right side.

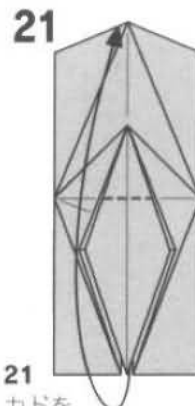

21
カドを
ひらくところで上に折る
Fold up and open
inner folded layers.

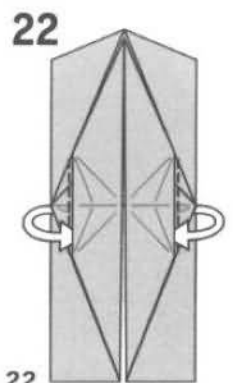

22
上の線のところ
でカドを内側に折る
Fold inside along the
edges on the top.

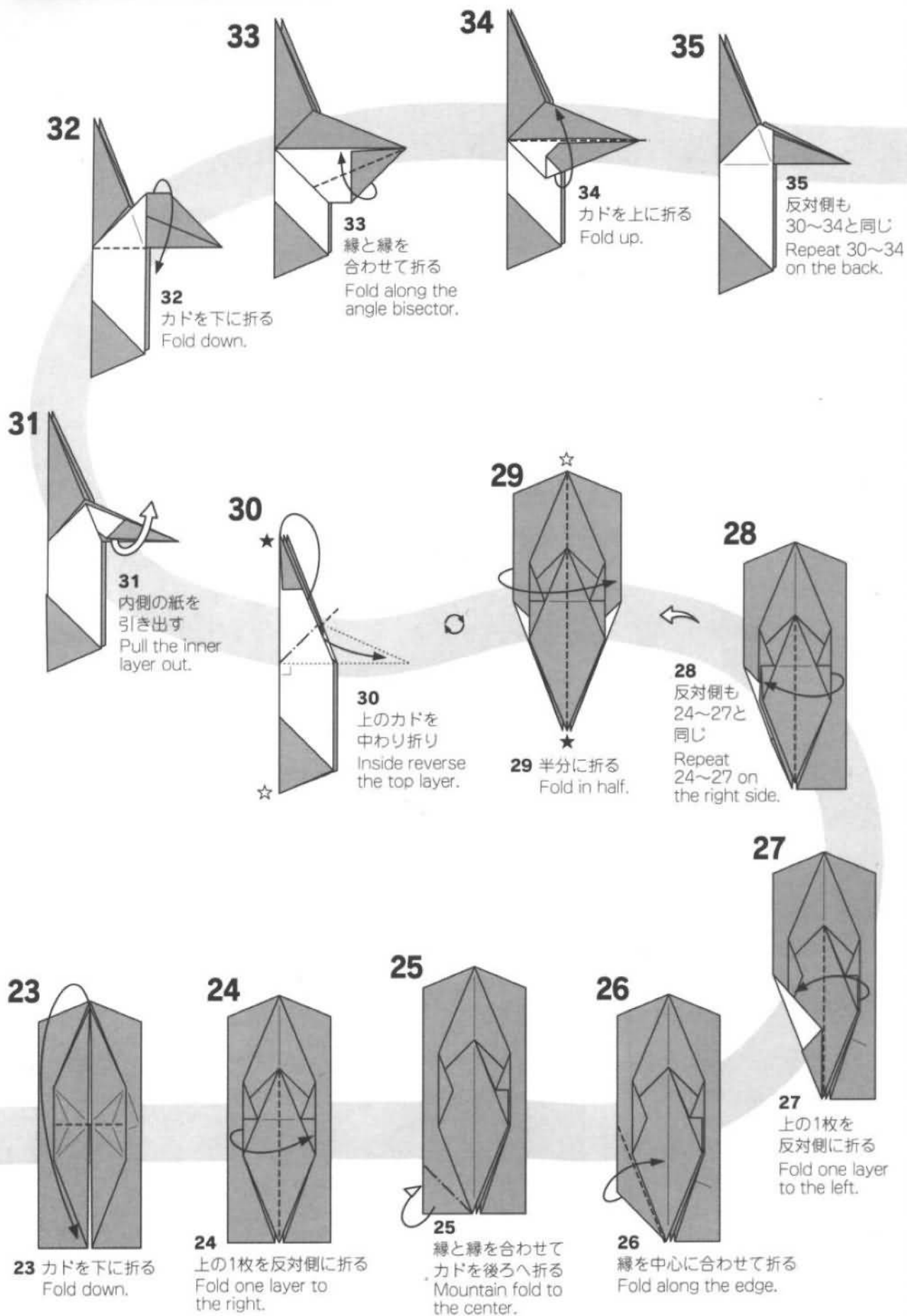

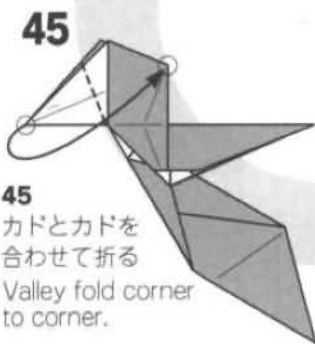
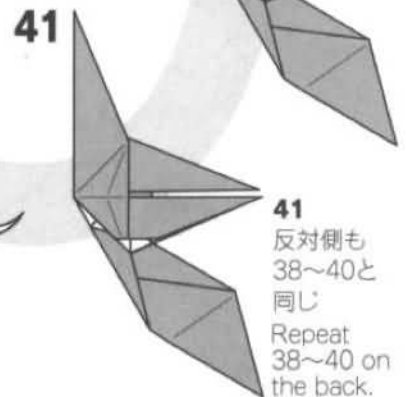
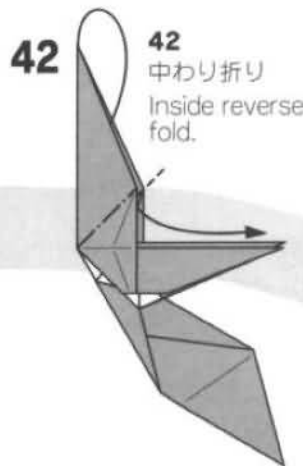
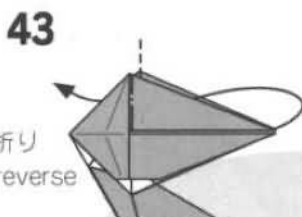
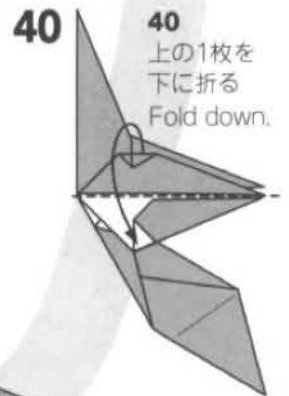
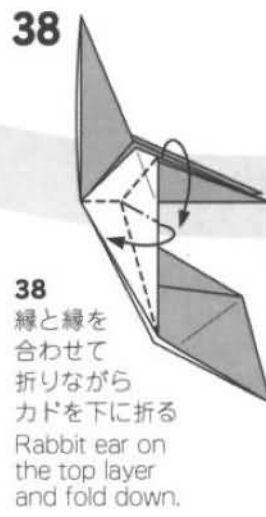
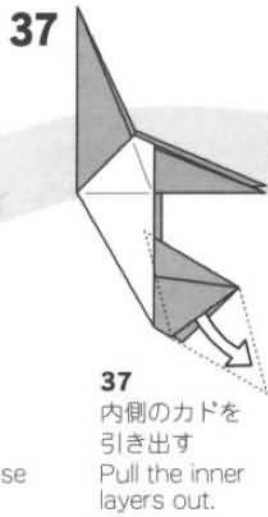
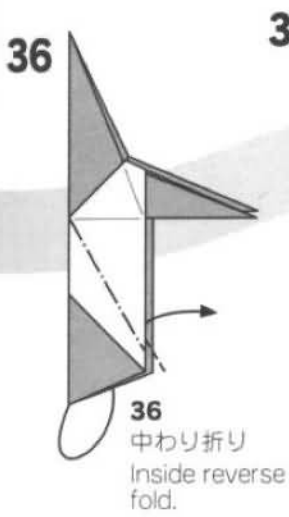

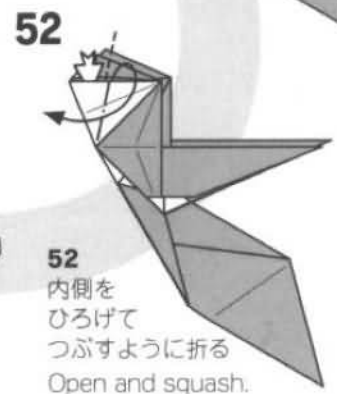
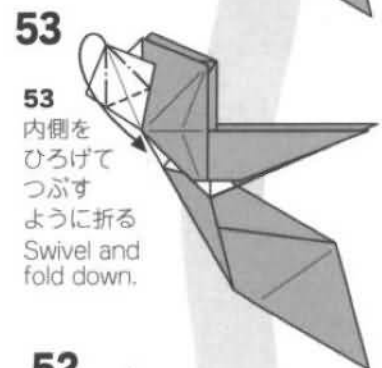
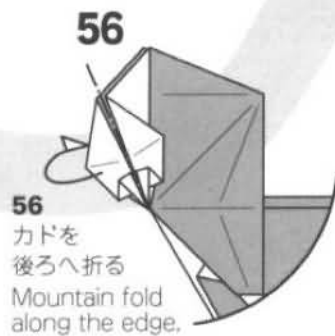
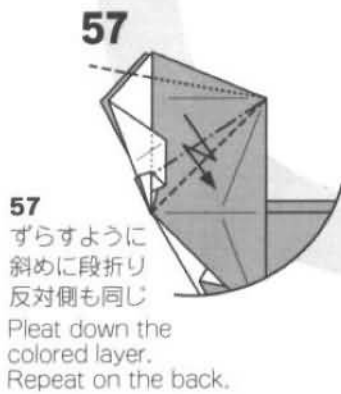
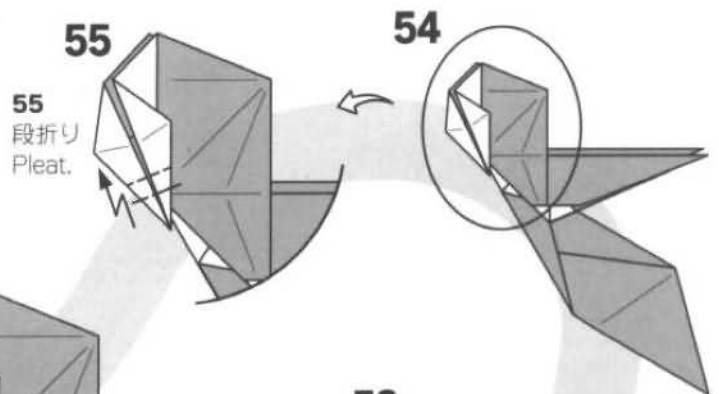
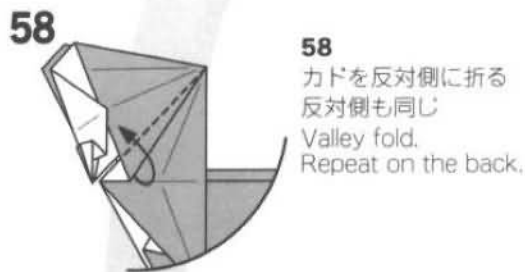
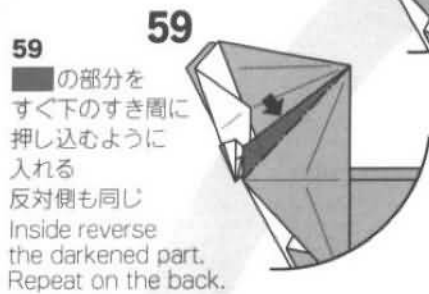
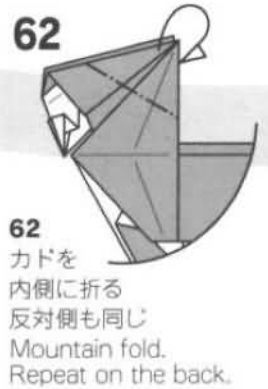
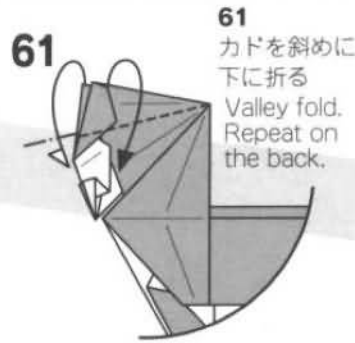

63

63
鼻の部分を
引き出す
Pull out
the nose.



64



65

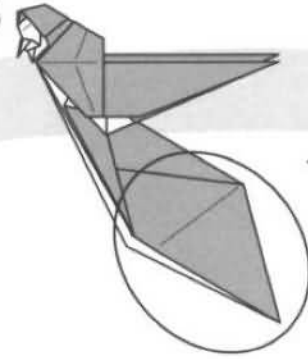

66

66
中わり折り
Inside reverse
fold.



67

67
カドを内側に折る
Inside reverse
along the edge.

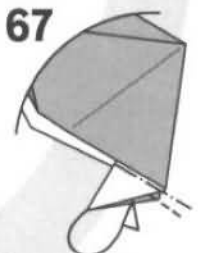

70

70
内側のカドを
縁と縁を合わせて
内側に折る
Inside reverse so
that the inner edge
aligns with the
outer edge.

70

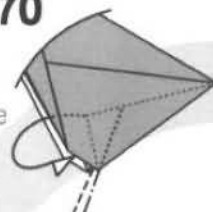

69

69
内側に
斜めに段折り
Pleat internally.

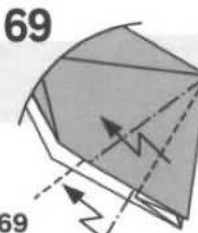

68

68
縁を折り筋に合わせ
て折り筋をつける
反対側も同じ
Precrease along
the angle bisector.

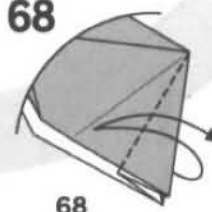

71

71
残りのカドも同じ
Repeat 70 on
the lower layers.

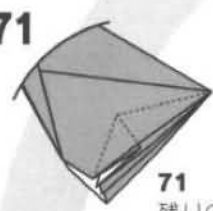

72

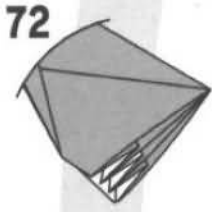

76

できあがり
Model
Completed

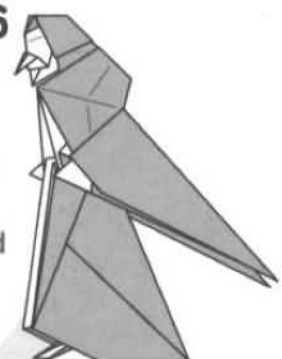

73

73
かぶせる
ように
斜めに
段折り
Pleat outside.

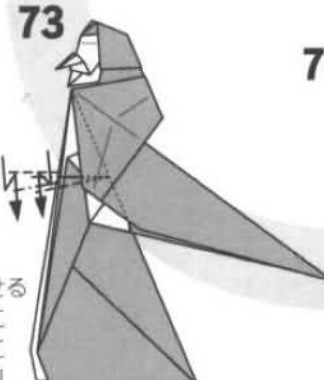

74

74
斜めに段折り
反対側も同じ
Pleat outside.
Repeat on the back.



75

75
カドを内側に折る
Mountain fold so
that the feet show.

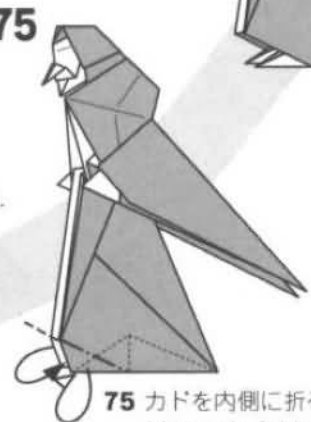

マーメイド

Mermaid

人魚の髪が水中で腕にからみつくようになびく。頭の中で“これしかない!”と思った形が、実際に手の中に現れたときの感動が忘れられません。構造が理解できれば2:3の長方形から1枚折りで試してみてください。小さく折ると結構かわいいですよ。

With her hair beautifully streamed in the sea current, this is the image of a mermaid I have in mind. You can try folding it from one 2:3 sheet of paper.



Created 1984 Paper 複合作品・2枚: 2 pieces

[上半身] Upper Part of the Body

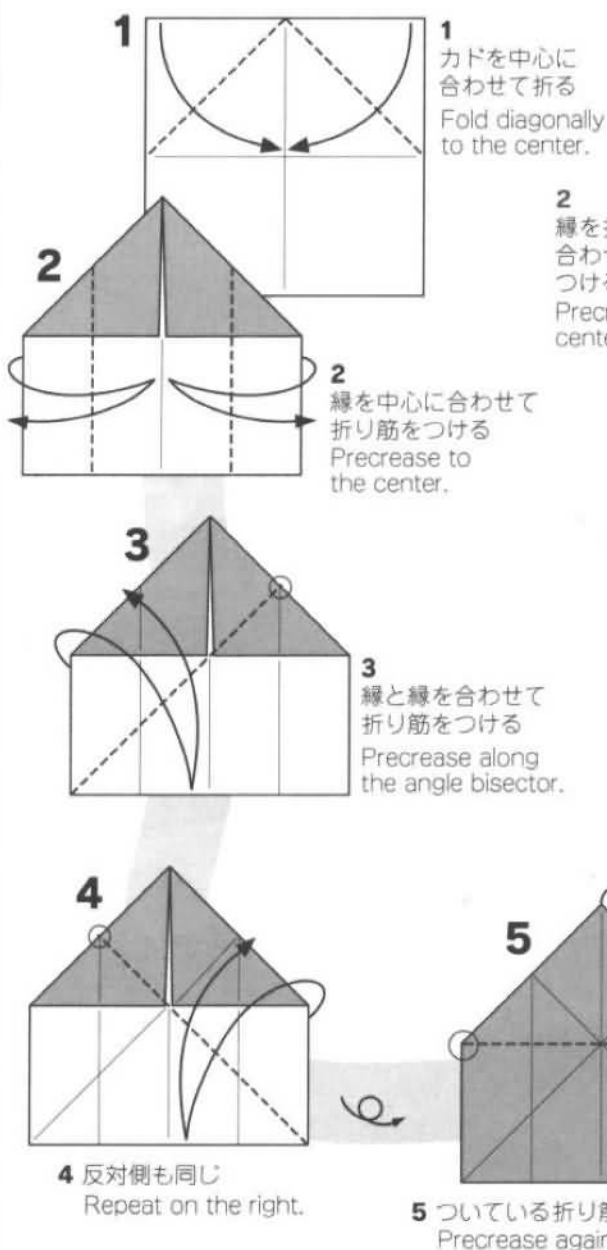

[下半身] Lower Part of the Body

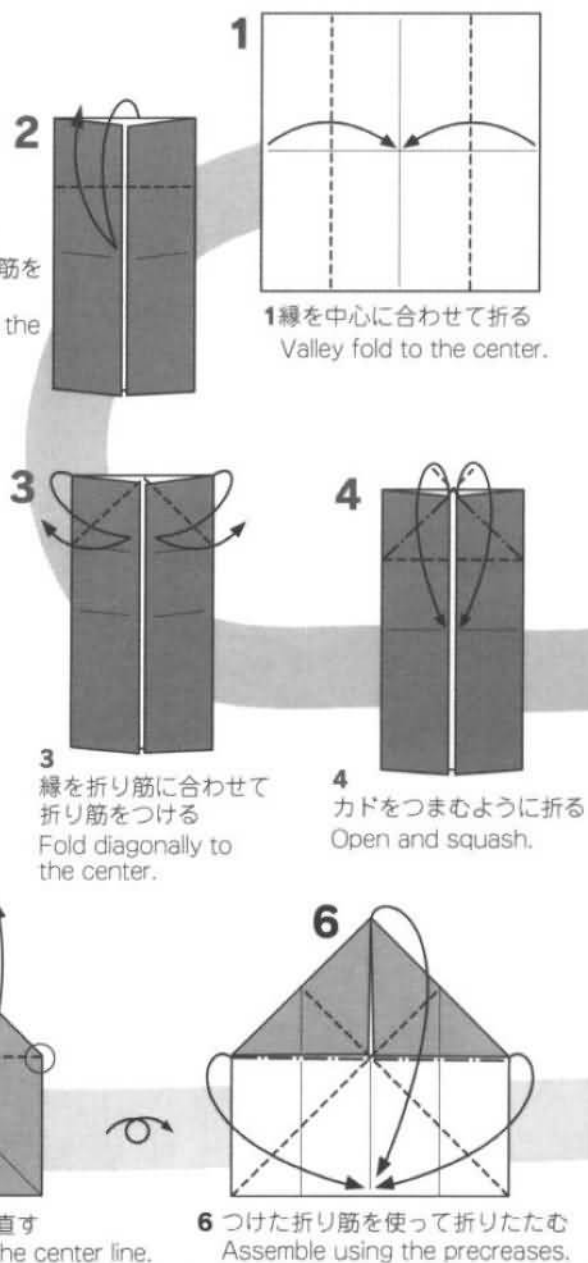

14
反対側も同じように
差し込んで組み合わせる
Repeat on the right.

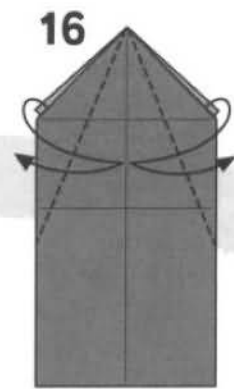
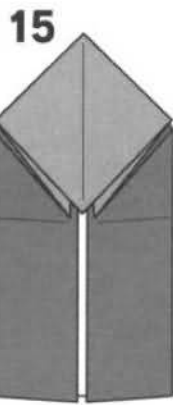
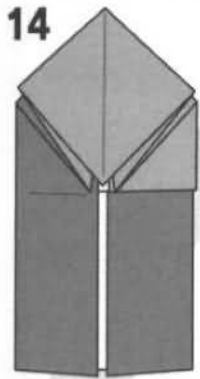

16
縁を中心に合わせて
折り筋をつける
Fold along the angle
bisectors.

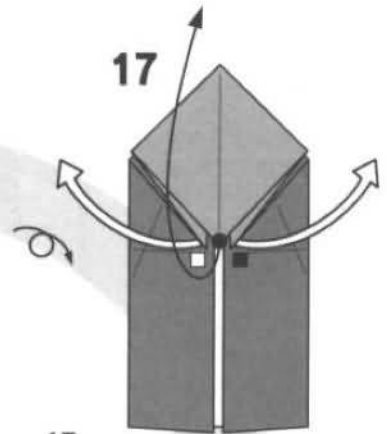

17
内側をひろげ●のカドを
後ろに倒すようにして折りたたむ
Pull up the top layer and
open the two hidden corners.

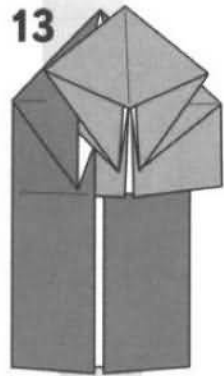

13
途中の図
Inserting...

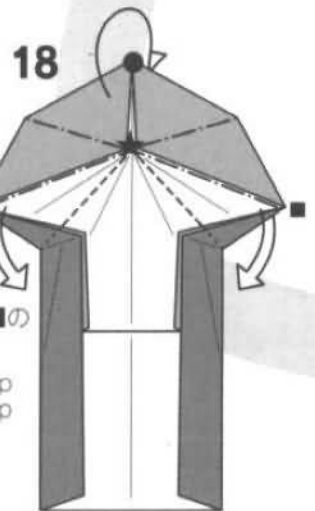

18
途中の図
カドを後ろに倒し□と■の
カドを元の位置に戻す
Outside reverse the top
layer and swivel the top
corner, and then fold
back the rest.

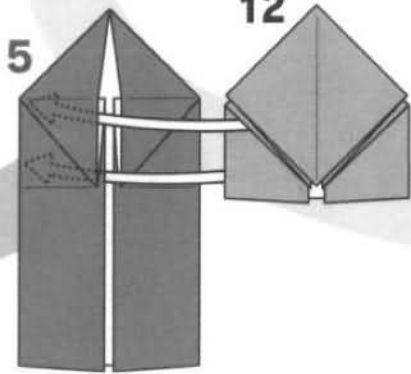

5
下半身のすき間に上半身を差し込む
Insert the bottom two layers on the
left of the upper body into the
corresponding two pockets of the
lower body.

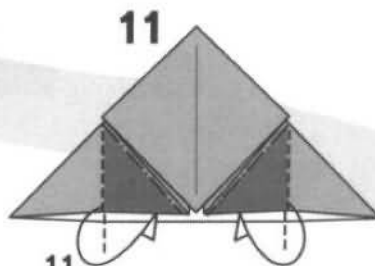

11
■の部分の内側に折る
Mountain fold the darkened
parts so that the corners
are squashed.

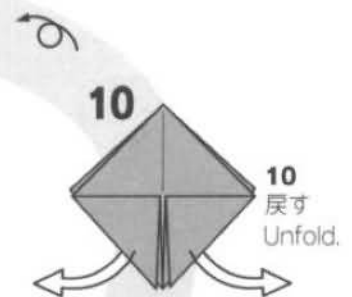

10
戻す
Unfold.

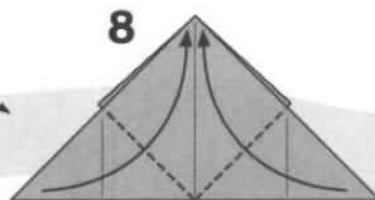
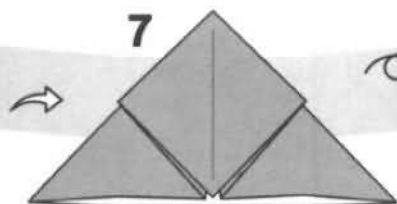

8
カドとカドを合わせて折る
Fold corner to corner.

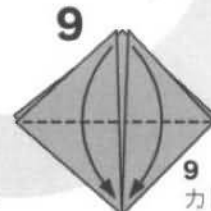

9
カドとカドを合わせて折る
Fold down to the bottom
corner.

28

矢印の部分を
押し込むようにして折る
Push and valley fold
along the line indicated
by an arrow, while
making a white bird
base around.

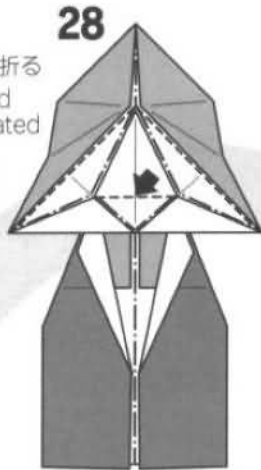

29

途中の図
Fold the white
bird base up
in half.



30

カドを内側に折る
Inside reverse fold.

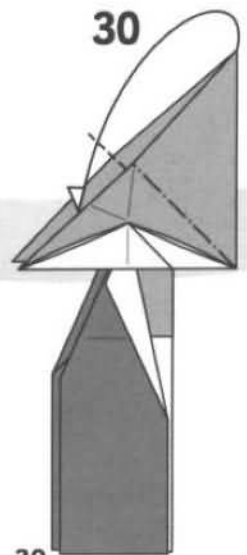

27

ひろげる
Open up.

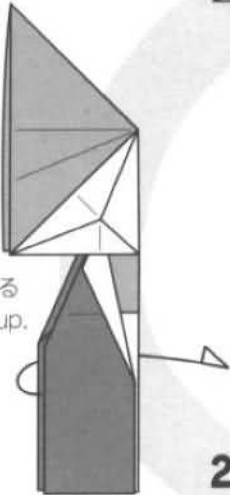

26

カドを引き上げる
ようにして内側の
部分を引き出す
Pull out the hidden
layers.

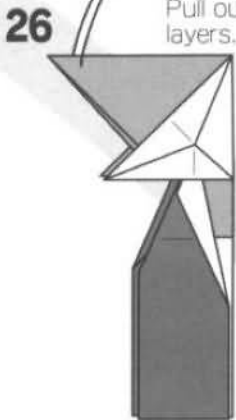

19

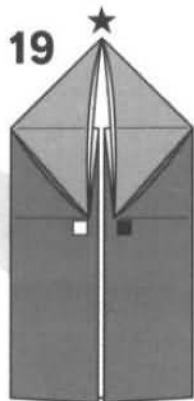

25

反対側も
23~24と
同じ
Repeat
23~24 on
the back.



24

この部分は
内側だけ折る

24
縁と縁を
合わせて折る
Fold the inner
layer so that
the short edge
on the right
aligns with
the long edge
on the left.



6

20

この部分は
内側だけ折る

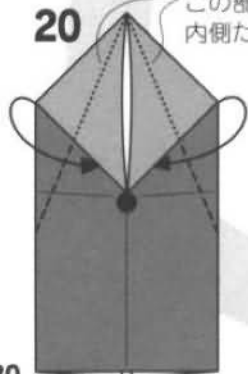

20
カドを中心に合わせて折る
Fold only inner layers to
the center.

21

21
半分に折る
Fold in half.



22

22
内側のカドを
引き出す
Pull out the
inner layer.



23

23
縁を折り筋に
合わせて折る
このとき
持ち上がってくる
部分をつぶす
ように折る
Valley fold along
the hidden edge
while squashing
the hidden layer.



31



31
カドを少し折る
反対側も同じ
Fold up the inner
layer a little.
Repeat on the back.

この部分は
内側だけ
折る

40

内側のカドを
うしろに折る
Mountain fold
the inner corner.

40

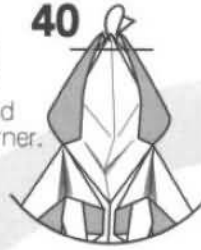

41



41
ずらした紙を戻す
Put back the slided
layers.

39



39
上の紙をつまんで
かるくずらすようにする
Open and slide the
top layers slightly.

32

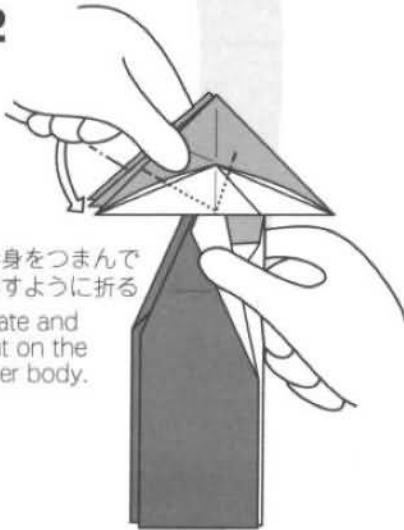

32
上半身をつまんで
ずらすように折る
Rotate and
pleat on the
upper body.



38



38
見る位置が
変わる
Front view.

37



37
反対側も
35~36と同じ
Repeat
35~36
on the back.

33

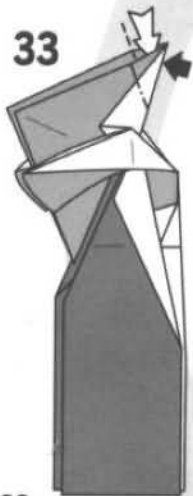

33
内側をひろげて
押しつぶすように折り
顔になる部分を
平らにする
Squash and mold
the face to the taste.

34

34 途中の図
Squashing...

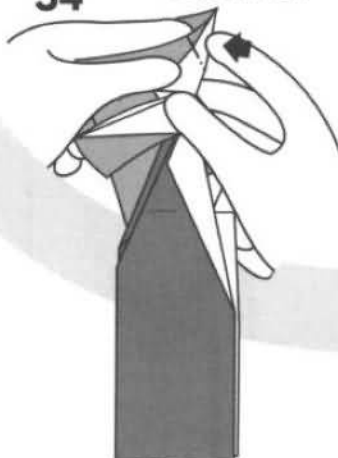

35



35
カドを下の線のところで折る
Fold down along the edge.

36

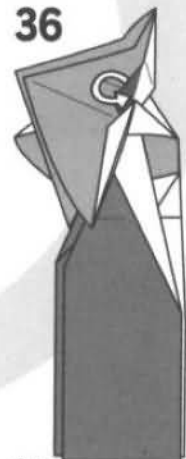

36
カドをすき間に差し込む
Tuck the corner
into the pocket.



42

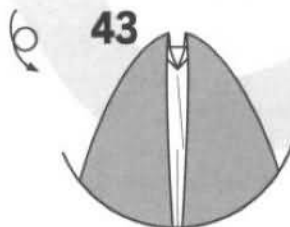

43



44

44 カドを内側に折り込む
Inside reverse fold.



45

45 反対側も同じ
Repeat on the back.



46

46 中わり折り
Inside reverse fold.

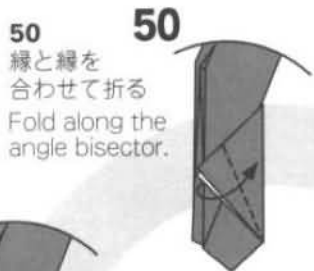

50

50 縁と縁を合わせて折る
Fold along the angle bisector.

50

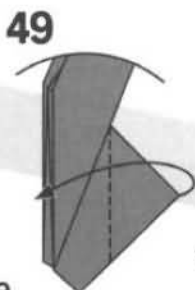

49

49 カドを反対側に折る
Valley fold.

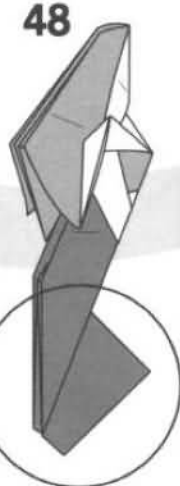

48



47

47 縁に沿って中わり折り
Inside reverse fold along the edges.



51

51 戻す
Unfold.



52

52 つけた折り筋で内側に折る
Inside reverse fold along the precrease.

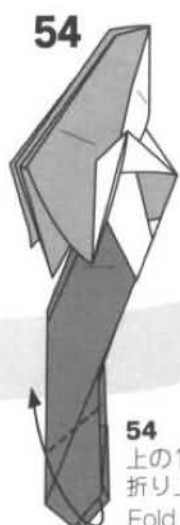

54

54 上の1枚を折り上げる
Fold up the tail.



55

55 体をひねる
Twist the body to the taste.



53

53 つけた折り筋で内側に折る
Inside reverse fold along the precrease.



56

できあがり
Model Completed

ペガサス

Pegasus

ペガサスは、馬か鳥か? 馬に翼を付けようとして苦勞していたある時、ふと鳥に足を付ければと思いついて、鶴の基本形から一気に原型ができました。鶴の背中に当たるところのボックスプリーツの隙間に余分な角を差し込み、同時に後ろ足が出来る工程がお気に入り。

Structurally, this Pegasus is a bird with four legs rather than a horse with wings. Starting from a bird base, this work makes a good use of the "back of a crane" (note 56-61).



Created 1993 Paper 不切正方一枚折り: 1 piece

P. 8 [鶴の基本形] からはじめる
Start with [Bird Base] (P.8)

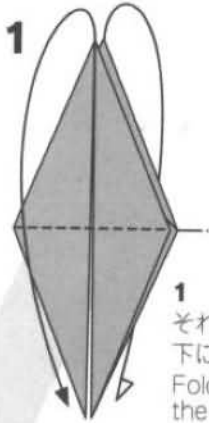

1
それぞれカドを
下に折る
Fold down
the top layers.

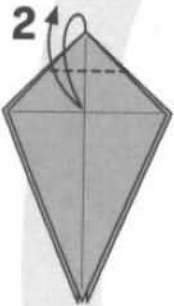

2
カドを折り筋に
合わせて
折り筋をつける
Fold down to
the intersection.

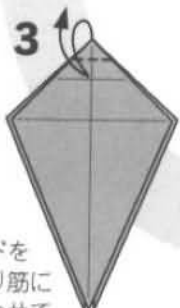

3
カドを
折り筋に
合わせて
折り筋をつける
Fold down to
the intersection
made in 2.

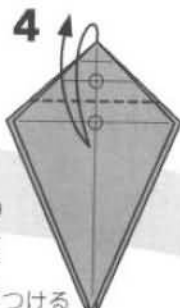

4
○と○の
折り筋を
合わせて
折り筋をつける
Fold down so that
the circled intersections
align with each other.

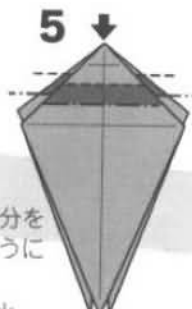

5
■の部分
沈めるように
段折り
Open sink
the middle portion.

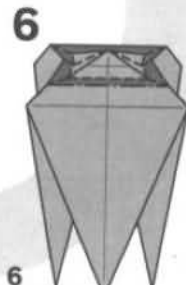

6
途中の図
Note the pleats
on the four sides.

9
反対側も同じ
Repeat on
the left.

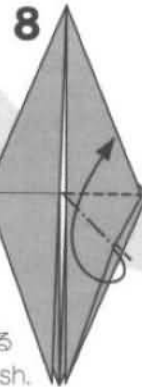
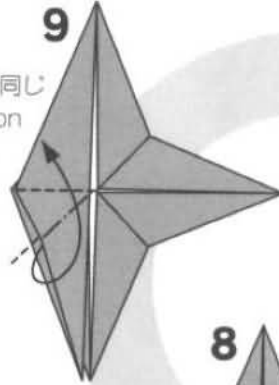

8
内側をひろげて
つぶすように折る
Open and squash.

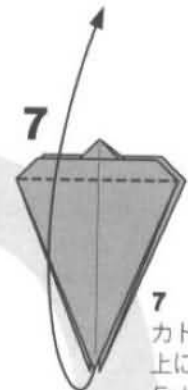

7
カドを
上に折る
Fold up.

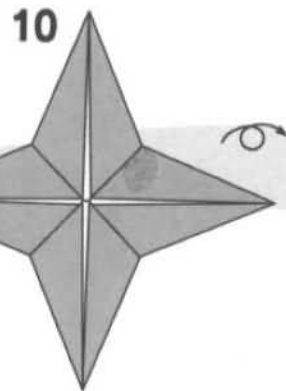

10

12
途中の図
Squashing.

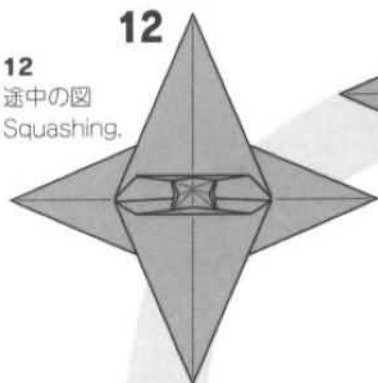

13
中わり折り
Inside reverse folds.

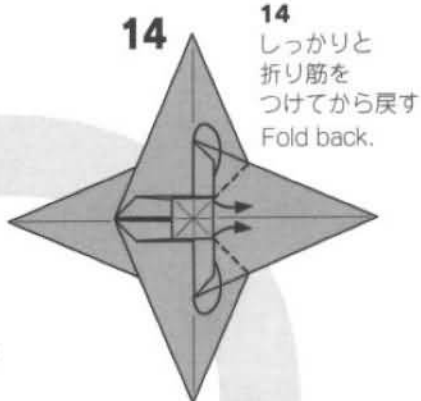

14
しっかりと
折り筋を
つけてから戻す
Fold back.

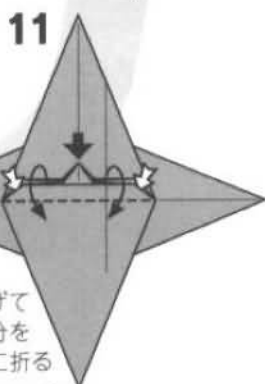

11
内側をひろげて
黒矢印の部分
つぶすように折る
Open and squash
the corner into
a small square.

15
カドを内側に折る
Inside reverse on
the lower next
layers.

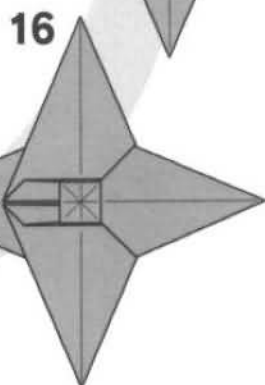
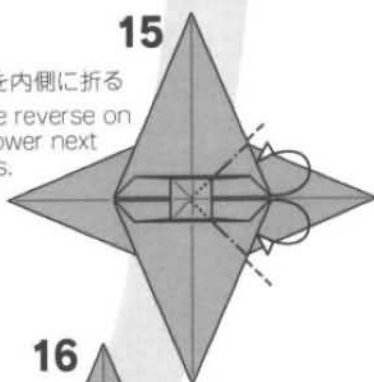

17
カドを中心より
少し離れたところに
合わせて
折り筋をつける
Fold the corner to
the point slightly
left of the center.

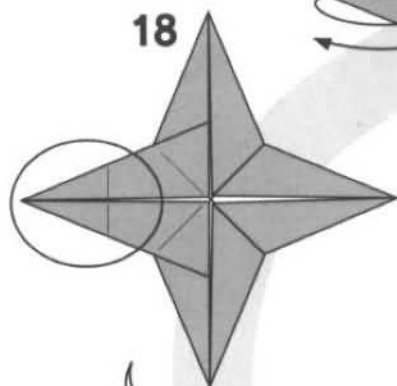

19
縁を折り筋に
合わせて
折り筋をつける
Align the lower edge to
the precreased line.

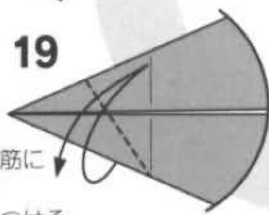

20
縁を折り筋に
合わせて折る
Align the upper edge to
the precreased line.

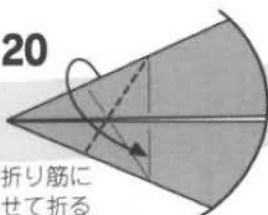

21
カドをつまむ
ように折る
Rabbit ear and fold up.

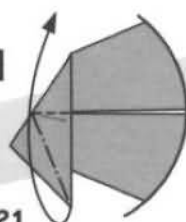

22
中わり折り
Inside reverse fold.

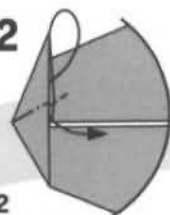

32

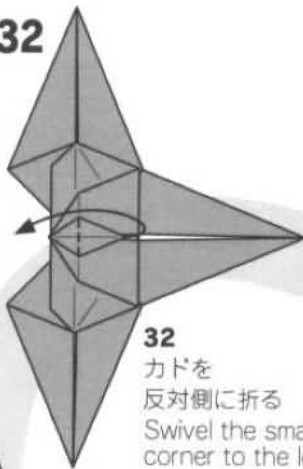

32
カドを
反対側に折る
Swivel the small
corner to the left.

33

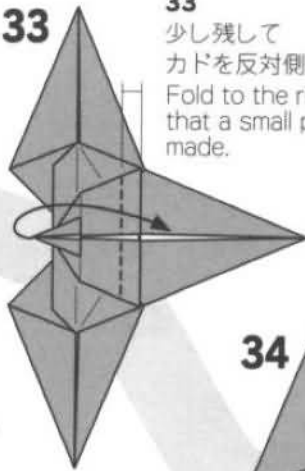

33
少し残して
カドを反対側に折る
Fold to the right so
that a small pleat is
made.

35

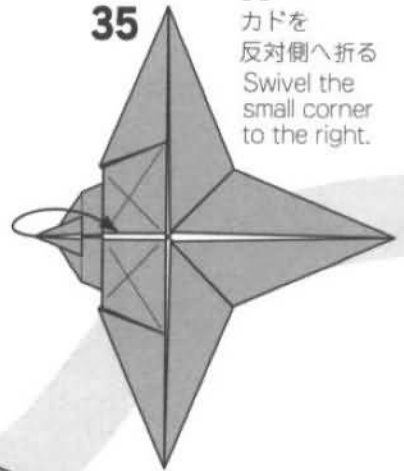

35
カドを
反対側へ折る
Swivel the
small corner
to the right.

31

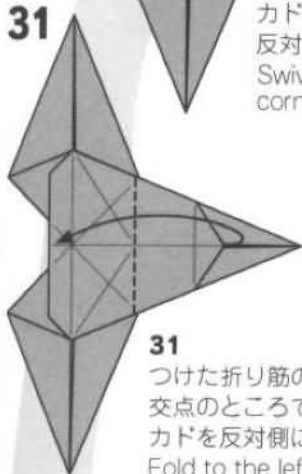

31
つけた折り筋の
交点のところで
カドを反対側に折る
Fold to the left at
the intersection.

34

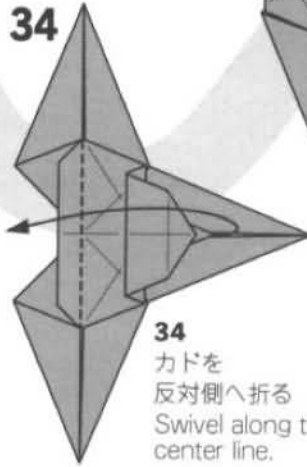

34
カドを
反対側へ折る
Swivel along the
center line.

30

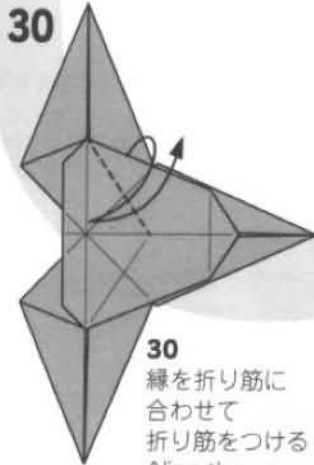

30
縁を折り筋に
合わせて
折り筋をつける
Align the upper edge
to the center line.

29

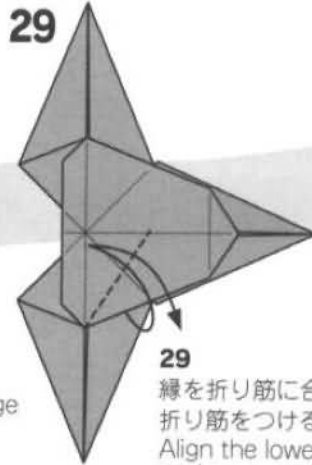

29
縁を折り筋に合わせて
折り筋をつける
Align the lower edge
to the center line.

28

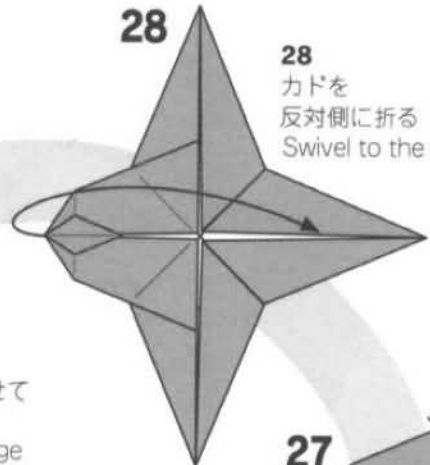

28
カドを
反対側に折る
Swivel to the right.

27

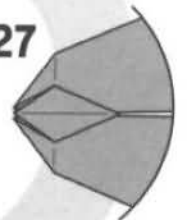

23

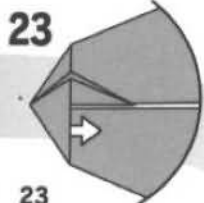

23
内側のカドを
引き出す
Pull out the inner
layer.

24

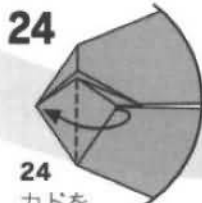

24
カドを
反対側に折る
Swivel.

25

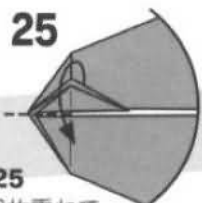

25
2枚重ねて
カドを下に折る
Fold down two layers.

26



26
反対側も
23~24と同じ要領で
27の図になるように折る
Repeat 23~24 on the upper part.

36

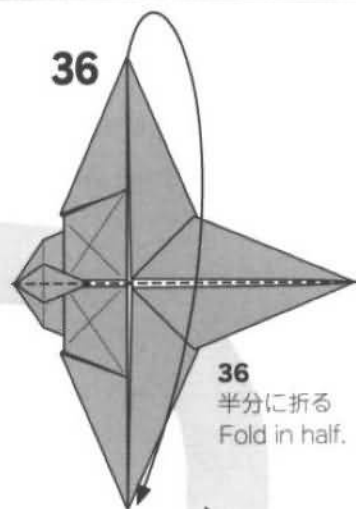

36
半分に折る
Fold in half.

37

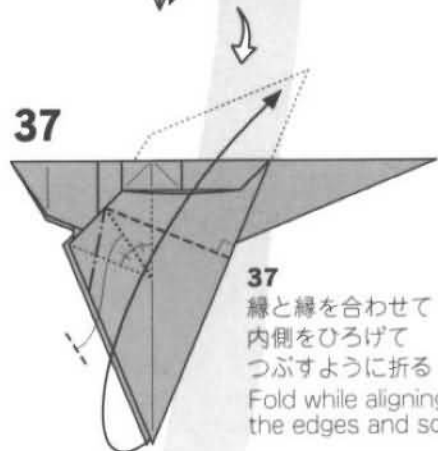

37
縁と縁を合わせて
内側をひろげて
つぶすように折る
Fold while aligning
the edges and squash.

38

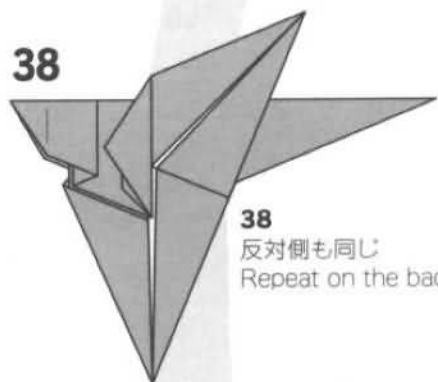

38
反対側も同じ
Repeat on the back.

39

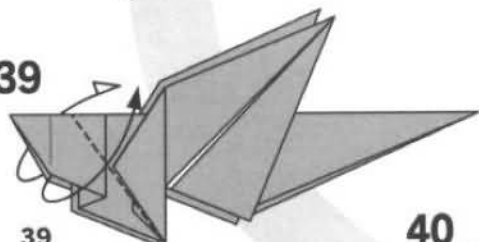

39
かぶせ折り
Outside reverse fold.

40

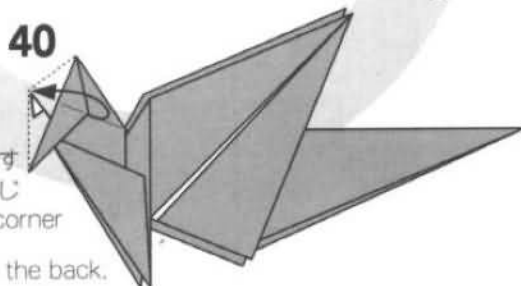

40
カドを起こす
反対側も同じ
Bring the corner
to the left.
Repeat on the back.

46



46
重なる部分を
内側から引き出す
反対側も同じ
Slide and separate
one layer.
Repeat on the back.

47

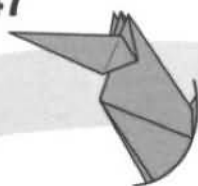

45

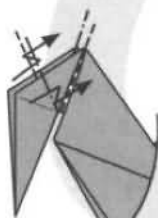

45
かぶせるように
斜めに段折り
Pleat outside.

44



44
しっかりと
折り筋を
つけてから戻す
Unfold.

43



43
2枚いっしょに
カドを縁に合わせて折る
Valley fold two layers
so that the middle corner
touches the left edge.

42

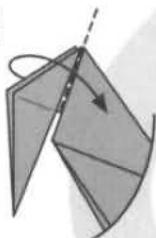

42
2枚いっしょに
縁のところで折る
Valley fold two layers
together.

41

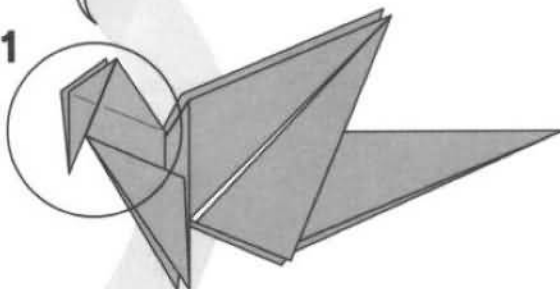

48

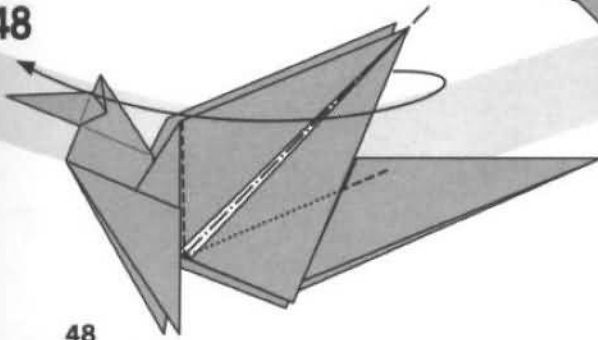

48

上の縁のところで
カドをつまむように折る
Fold a huge rabbit ear.

49

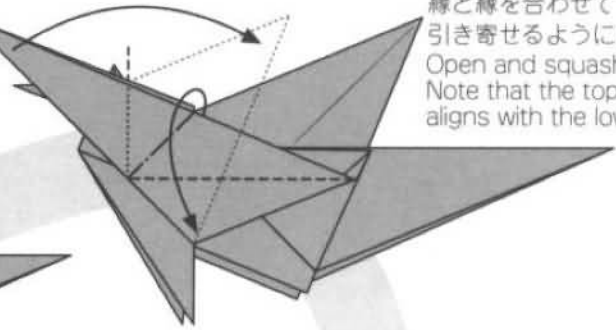

49

縁と縁を合わせて
引き寄せるように折る
Open and squash.
Note that the top edge now
aligns with the lower edge.

50

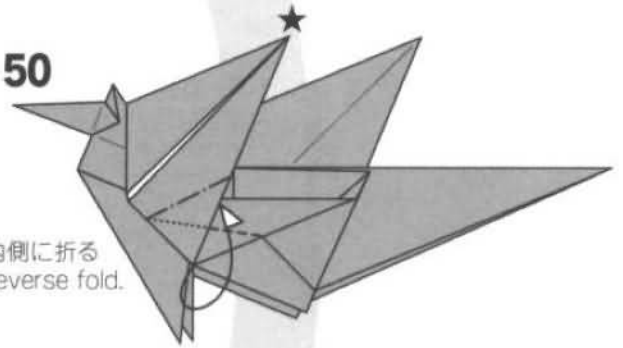

50

カドを内側に折る
Inside reverse fold.

51

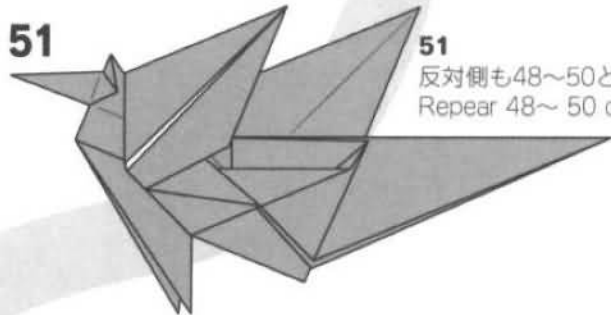

51

反対側も48~50と同じ
Repeat 48~ 50 on the back.

52

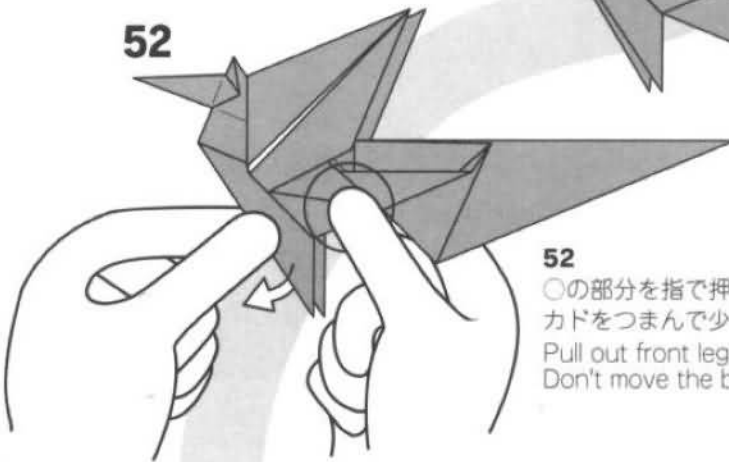

52

○の部分を指で押さえながら
カドをつまんで少し引き出す
Pull out front legs a little.
Don't move the body,

53

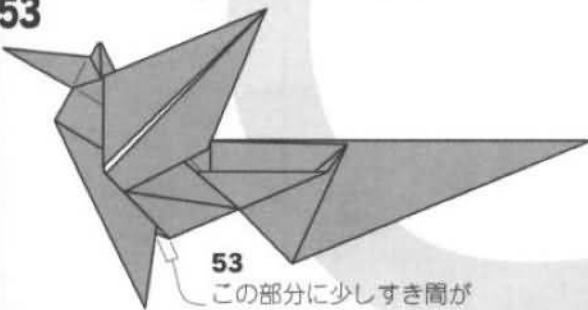

53

この部分に少しすき間が
できるようにする
... so that a small space can
be seen between legs and
the body.

54

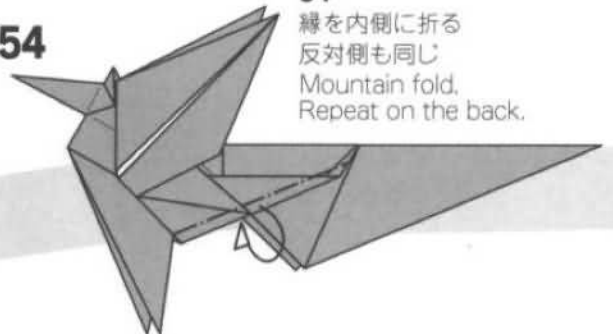

54

縁を内側に折る
反対側も同じ
Mountain fold.
Repeat on the back.

59

59
57の形に戻す
Unfold to 57.

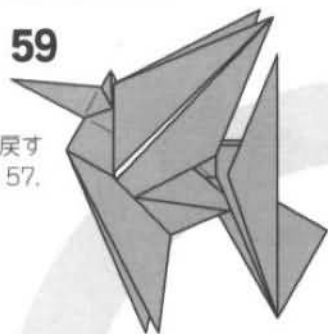

60

60
つけた折り筋で
かぶせるように段折り
Pleat outside on
the precreases.

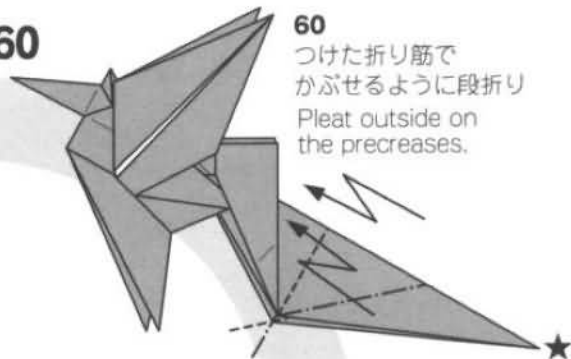

58

58
縁と縁を合わせて
カドを斜めに折る
Valley fold so that
the lower edge aligns with
the edge of the legs.

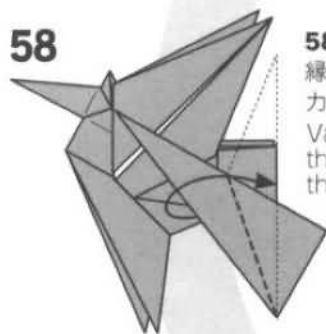

61

61
縁のところで
カドを内側へ折る
Inside reverse fold
along the edge.

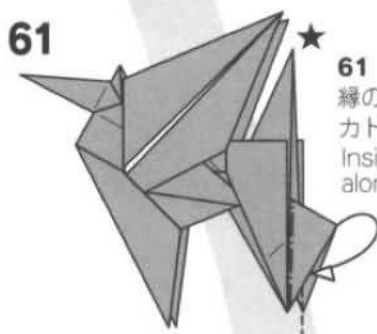

57

57
縁と縁を合わせて
カドを斜めに折る
Fold at a right angle.

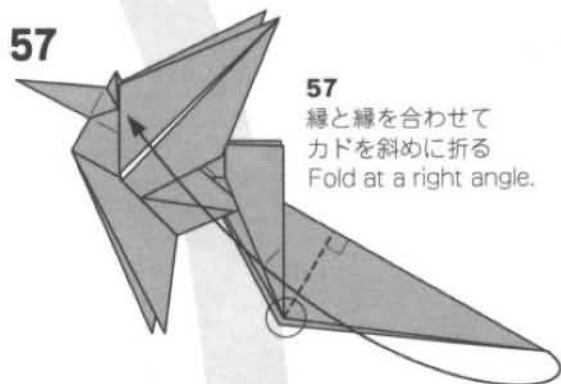

62

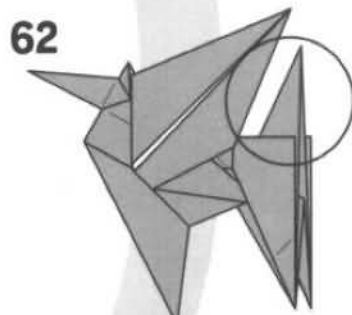

56

56
カドを折って
すき間に差し込む
反対側も同じ
Valley fold and tuck
the tip into the pocket.
Repeat on the back.

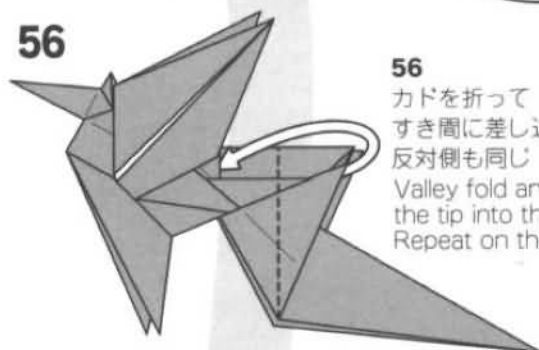

63

63
中わり折り
Inside reverse fold.

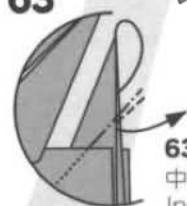

55

55
カドをつまんで
ずらすように折る
Slide the rear legs down.

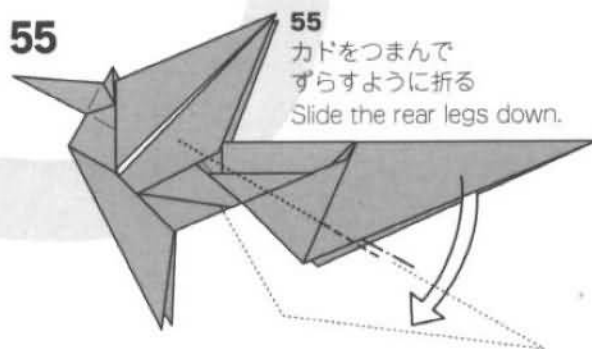

64

64
かぶせ折り
Outside reverse
fold.



65

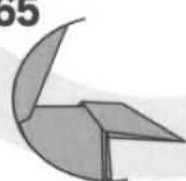

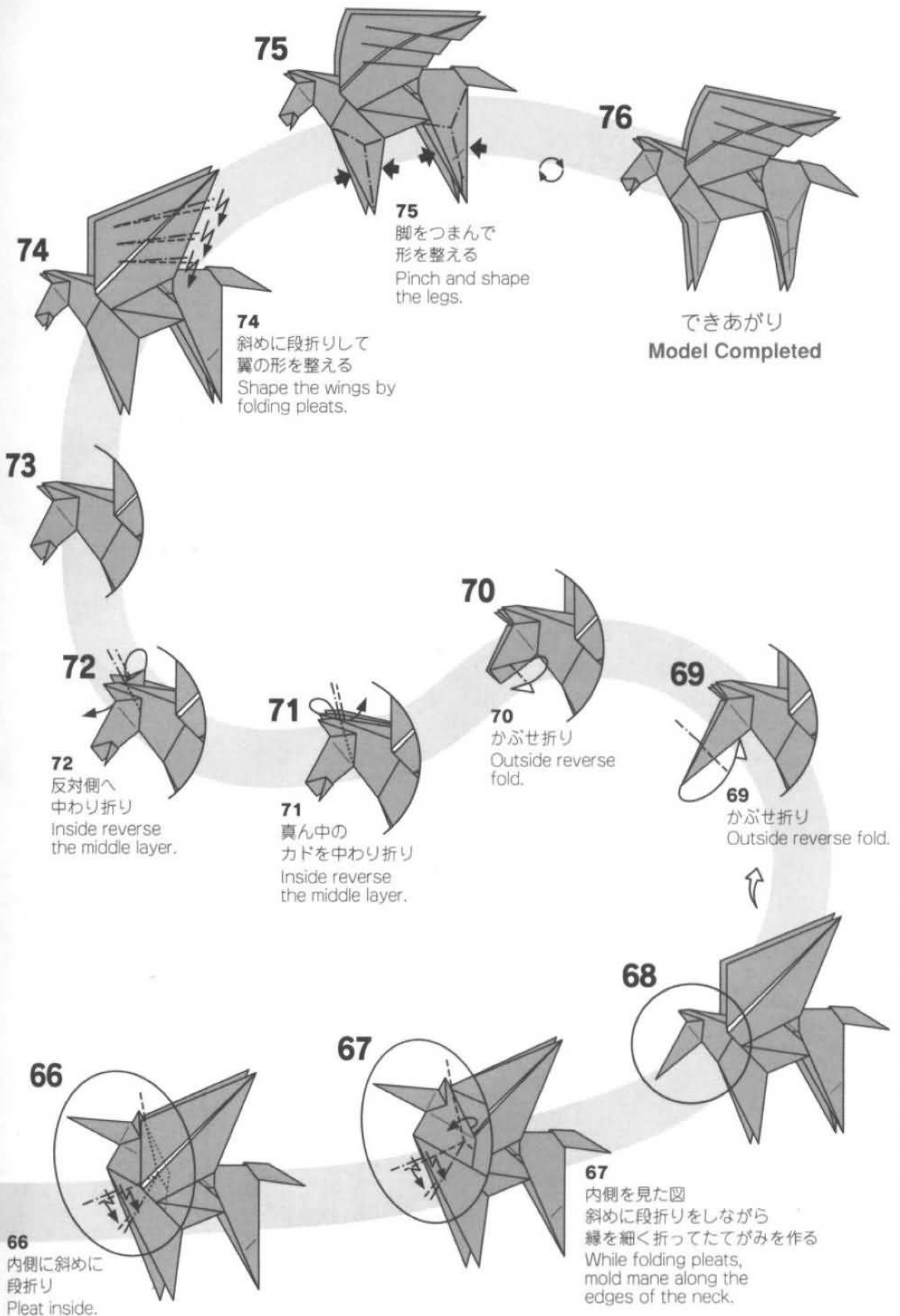

ドラゴン

Dragon

足と翼の点配置の原型は以前からあったものですが、1998年頃に前足の爪の折り方を中心に手順をまとめたものが本作です。翼の大きさを決めるはじめの仕込み折りは自由度が高くて、少くらしい比率が変わっても折り進んでいきます。頭部をしっかりと作るには、35センチ以上の用紙がおすすめです。

The base of this dragon has been in my mind for quite a while. This is a new version with more sophisticated folding methods on the nails. You can change the size of the wings to your taste. Use a large sheet to fold details.



Created 1998 Paper 不切正方一枚折り: 1 piece

1
縁を中心に合わせて
印をつける
Bend so that the
edges align with the
center line.
Put marks at
intersections.

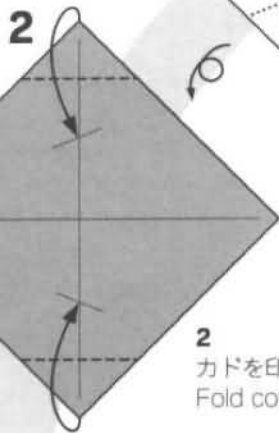
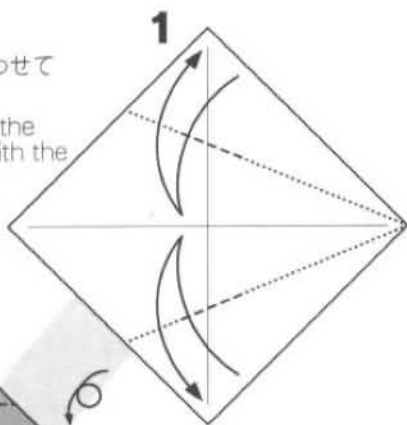

2
カドを印に合わせて折る
Fold corners to the marks.

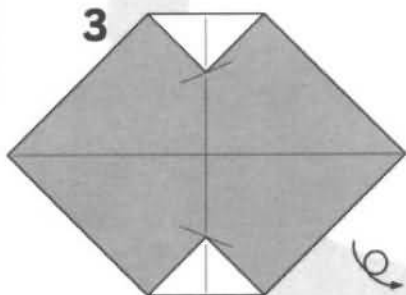

4
縁を折り筋に
合わせて折る
Valley fold so that
the upper edge aligns
with the center line.

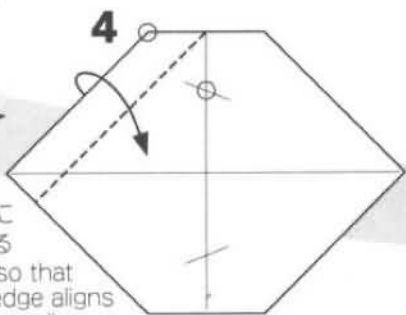

8
縁と縁を合わせて
折り筋をつける
Fold edge
to edge.

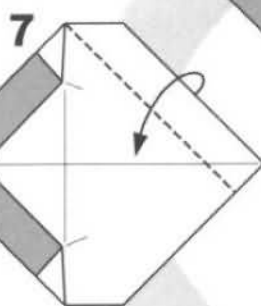
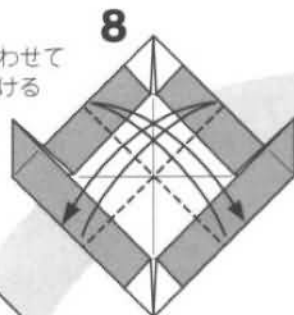

7
反対側も
4~6と同じ
Repeat 4-6
on the right.

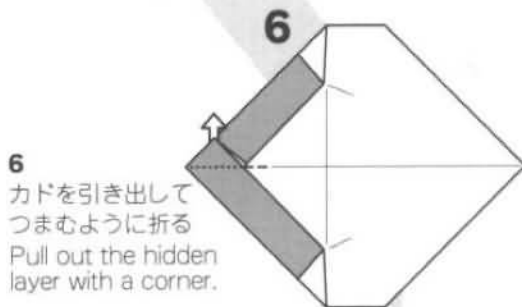

6
カドを引き出して
つまむように折る
Pull out the hidden
layer with a corner.

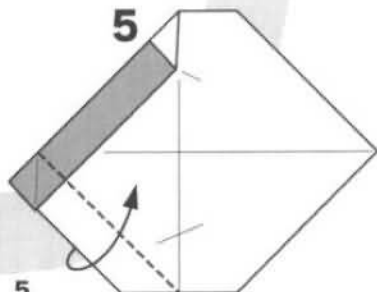

5
縁を折り筋に
合わせて折る
Repeat at the bottom.

10
カドとカドを
合わせて折る
Fold down
in half.

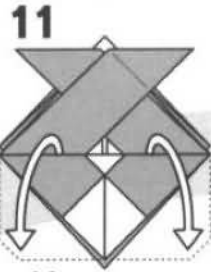
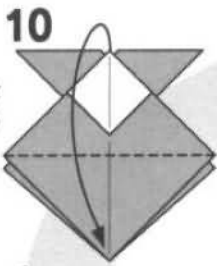

11
内側の紙を
引き出して開く
Pull out the hidden
layers on the left
and right.

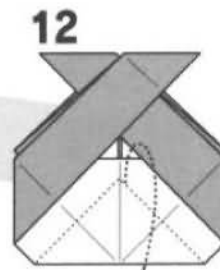

12
下のカドを出す
Pull down the
hidden corner.

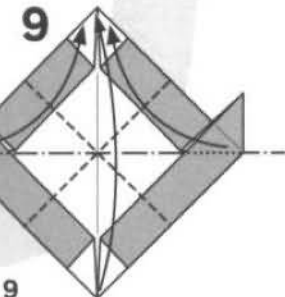
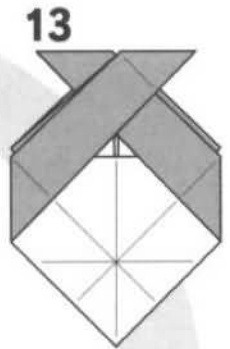

9
つけた折り筋で
折りたたむ
Fold like a preliminary
base.

14
10~12と
同じに折る
Repeat 10~12
on this side.

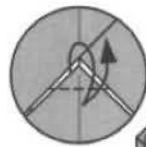
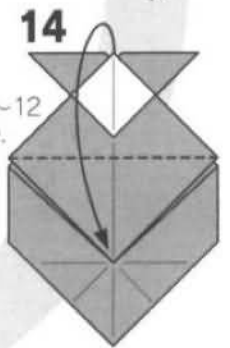

16
下の縁のところで
折り筋をつける
Precrease where
the hidden white edge is.

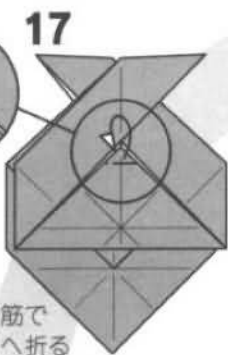

17
つけた折り筋で
カドを後ろへ折る
Mountain fold the tip.

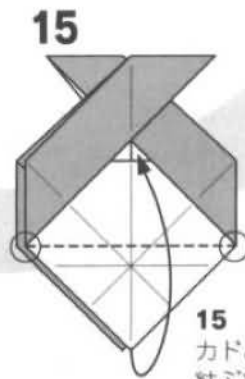

15
カドとカドを
結ぶ線で折る
Fold the white
square in half.

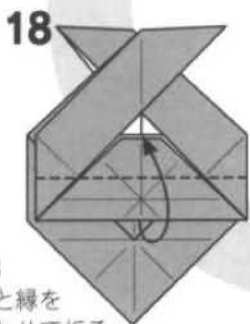

18
縁と縁を
合わせて折る
Fold up at
a half length.

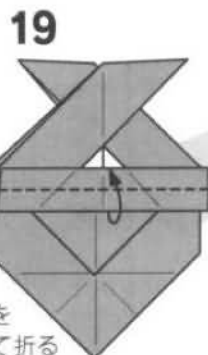

19
縁と縁を
合わせて折る
Fold up at a half length.

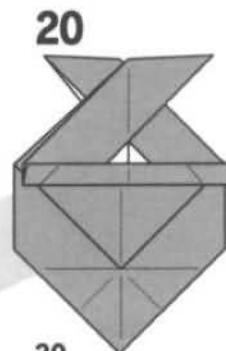

20
18の形まで戻す
Unfold to 18.

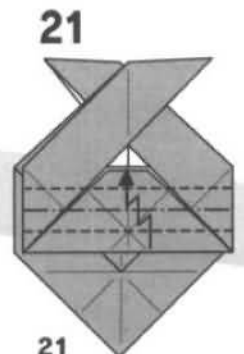

21
つけた折り筋を
使って段折り
Pleat along the
preceases.

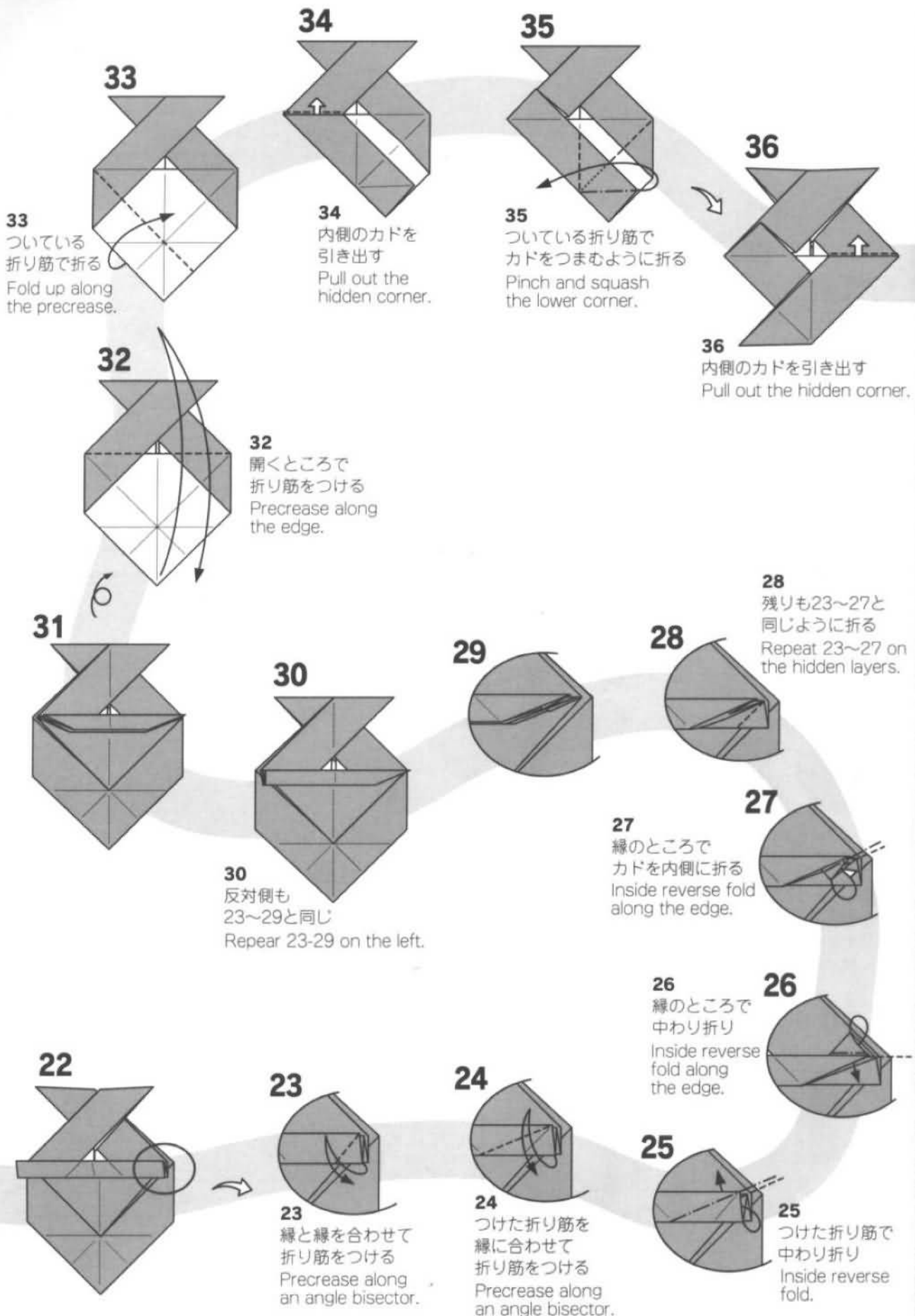

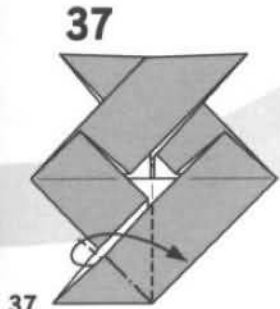

37
内側をひろげて
つぶすように折る
Open and squash.

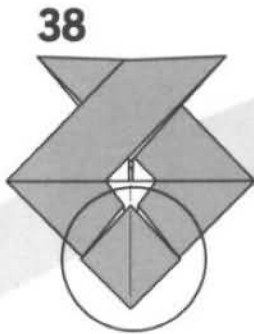

38

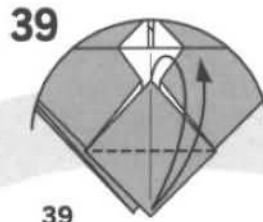

39

39
カドとカドを合わせて
折り筋をつける
Precrease along the
diagonal.

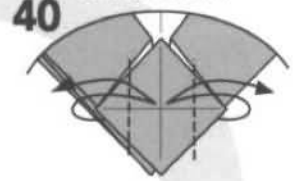

40

40
カドを中心に合わせて
折り筋をつける
Precrease the corners
to the center.

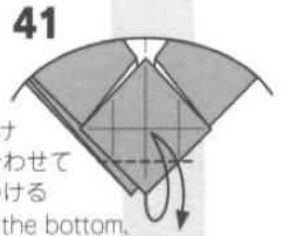

41

41
上の1枚だけ
折り筋に合わせて
折り筋をつける
Repeat at the bottom.

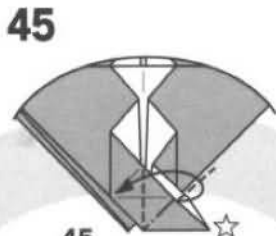

45

45
内側をひろげて
つぶすように折る
Open and squash.

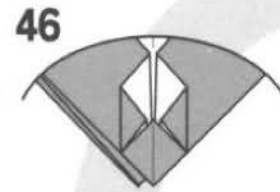

46

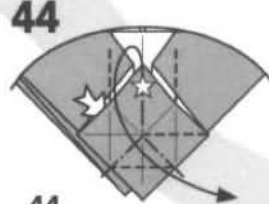

44

44
☆のカドをつまんで
つぶすように折る
Pinch the top corner
and fold down.

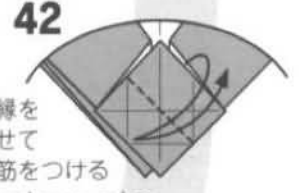

42

42
縁と縁を
合わせて
折り筋をつける
Fold edge to edge.

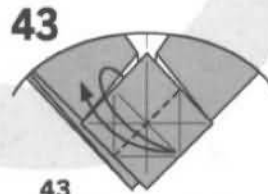

43

43
縁と縁を合わせて
折り筋をつける
Fold edge to edge.

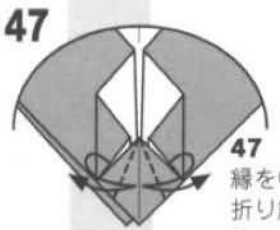

47

47
縁を中心に合わせて
折り筋をつける
Precrease along
angle bisectors.

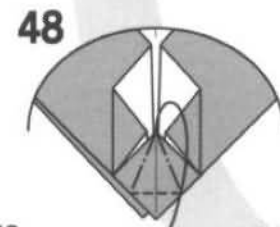

48

48
内側をひろげて
つぶすように折る
Form a bird base.

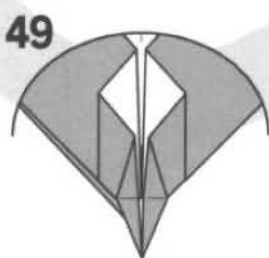

49

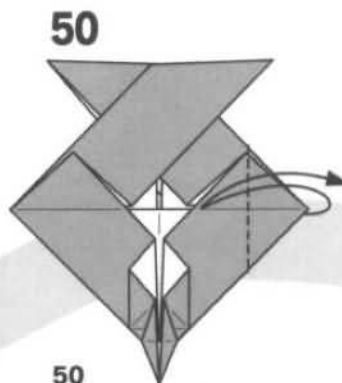

50

50
上の1枚だけ縁と縁を
合わせて折り筋をつける
Fold the corner to
the inner edge.

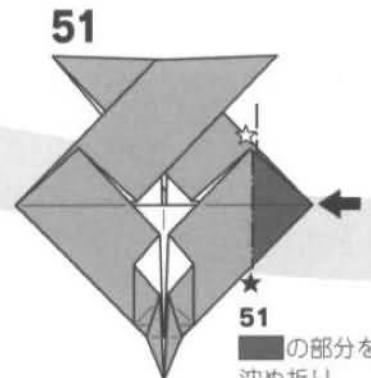

51

51
★の部分
を沈め折り
Open sink.

60
この部分は
立体になっている
These parts are
not flattened.

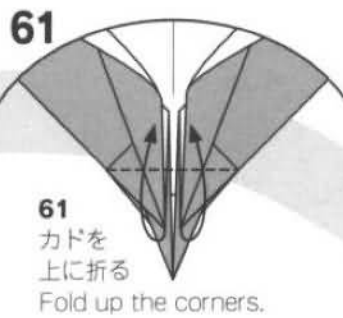
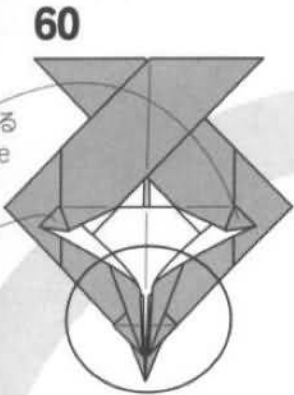

61
カドを
上に折る
Fold up the corners.

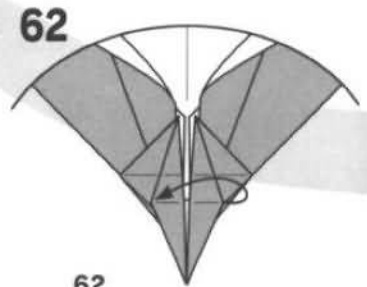

62
カドを反対側に折る
Fold the top layers
to the left.

59

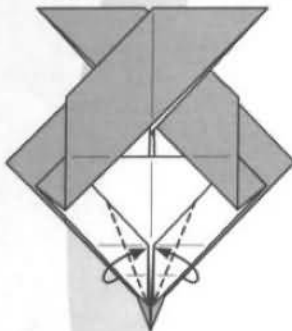

59
縁と縁を合わせて折る
Fold the two lower
edges to the center.

58

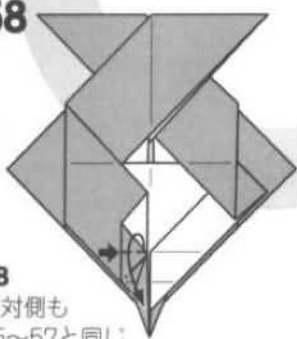

58
反対側も
55~57と同じ
Repeat 55~57 on the left.

57

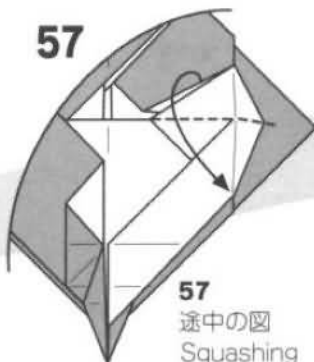

57
途中の図
Squashing
the top ...

56

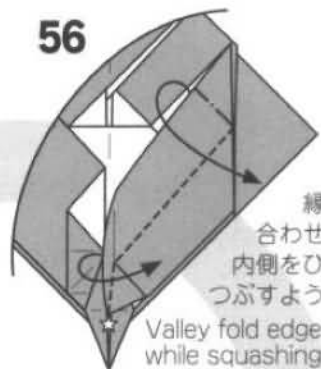

56
縁と縁を
合わせながら
内側をひろげて
つぶすように折る
Valley fold edge to edge,
while squashing the top
and bottom parts.

55

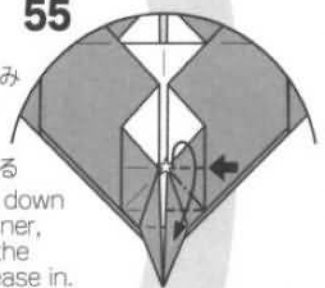

55
☆のカドをつまみ
黒矢印の部分
を押して全体を
起こすようにする
Pinch and fold down
the starred corner,
while pushing the
arrowed precrease in.

53

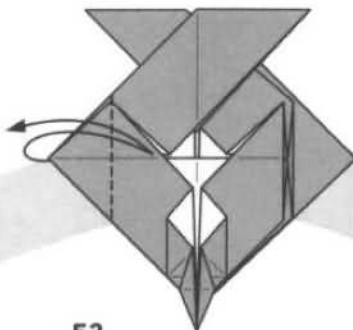

53
反対側も50~52と同じ
Sunk. Repeat 50~52
on the left.

52

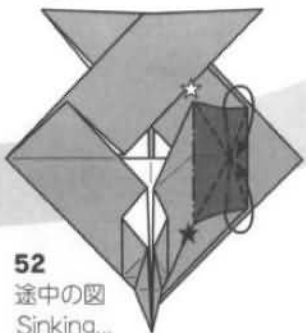

52
途中の図
Sinking...

54

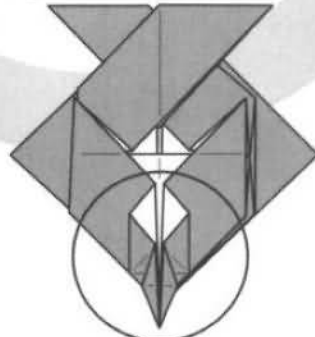

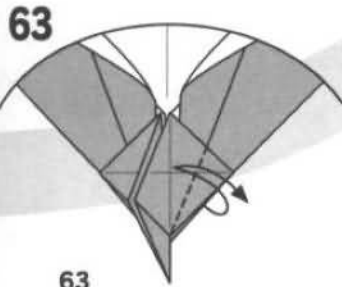

63
 縁を折り筋に合わせて
 折り筋をつける
 Fold the lower edge
 to the center line.

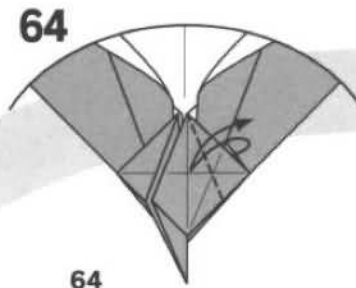

64
 縁を折り筋に合わせて
 折り筋をつける
 Fold the upper edge
 to the center line.

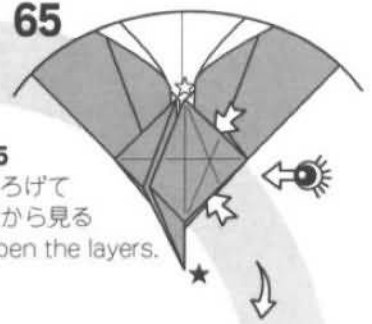

65
 ひろげて
 横から見る
 Open the layers.

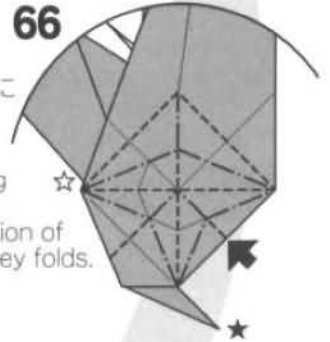

66
 図のような折り筋に
 つけなおして
 折りまとめる
 Reassemble using
 the precreases.
 Note the distribution of
 mountain and valley folds.

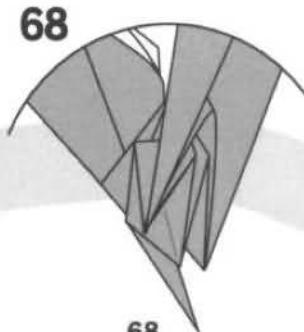

68
 途中の図
 Assembling ...

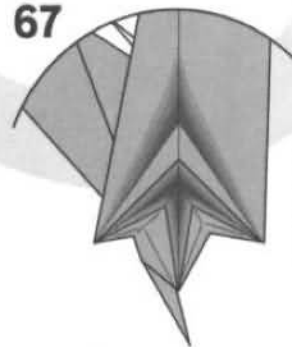

67
 途中の図
 そのまま
 折りまとめる
 Assembling ...

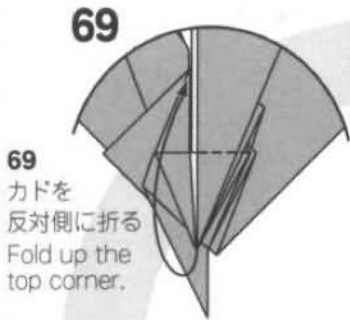

69
 カドを
 反対側に折る
 Fold up the
 top corner.

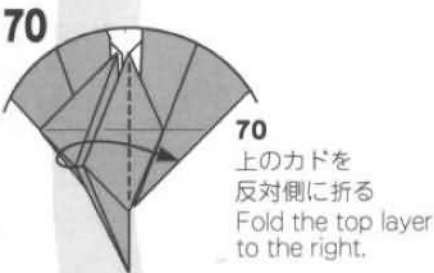

70
 上のカドを
 反対側に折る
 Fold the top layer
 to the right.

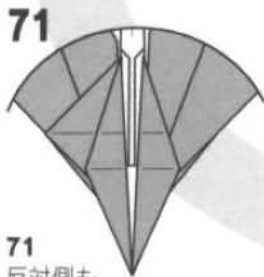

71
 反対側も
 62~70と同じ
 Repeat 62~70
 on the left.

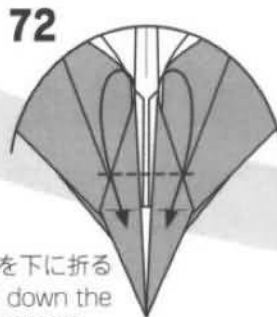

72
 カドを下に折る
 Fold down the
 top corners.

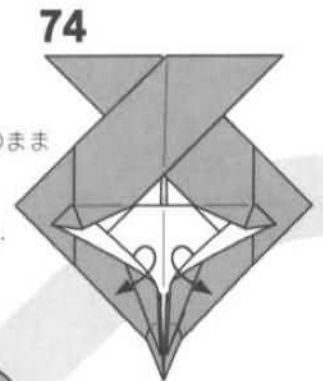
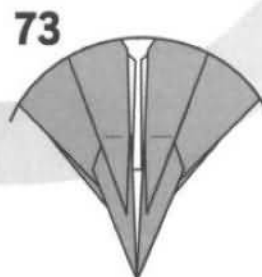

74
 この状態のまま
 縁を戻す
 Reopen
 the edges.

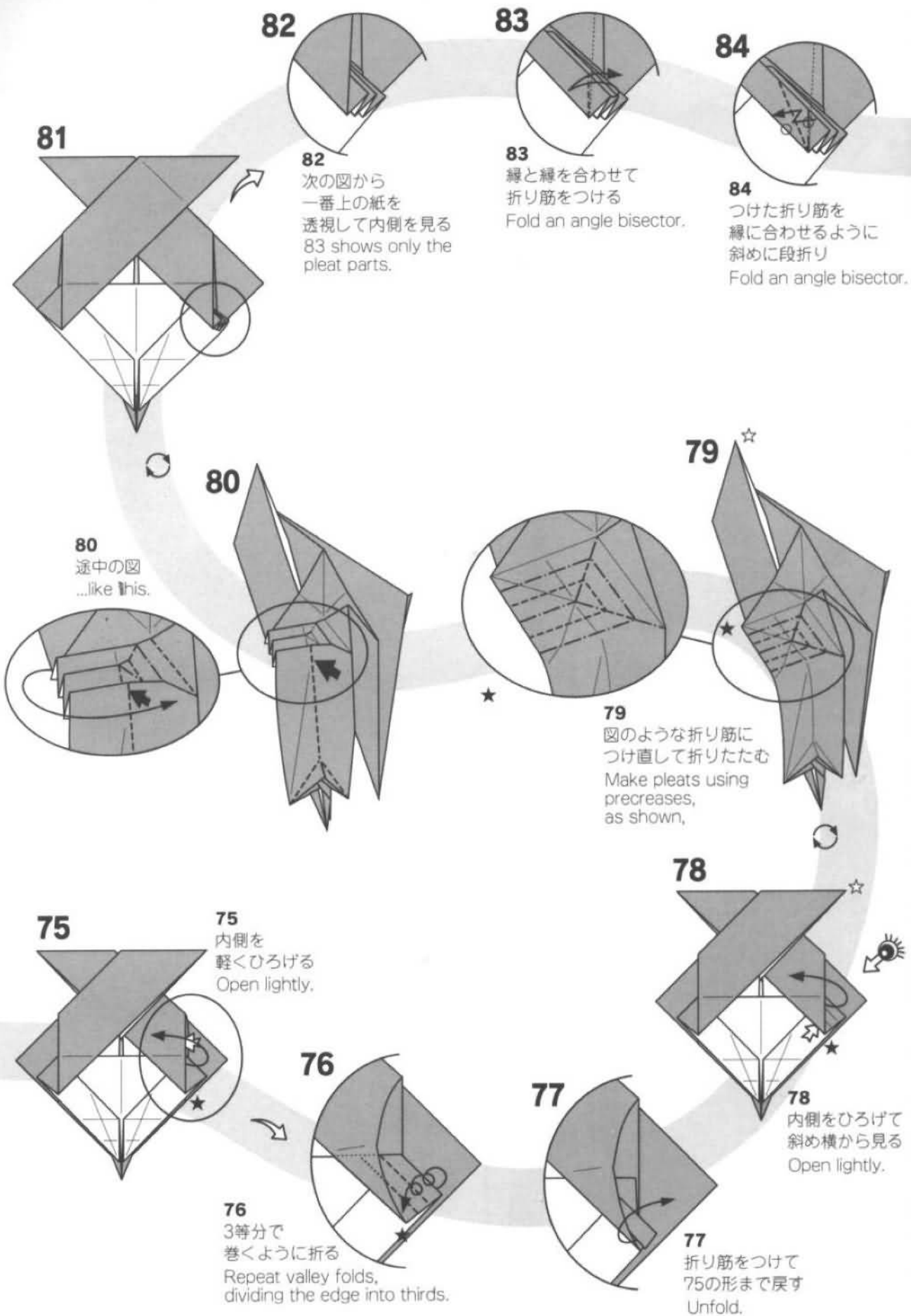

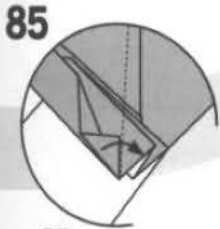

85
折り筋をつけてから戻す
Unfold.

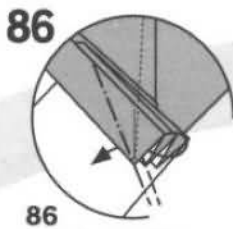

86
つけた折り筋で
中わり折り
Inside reverse fold.

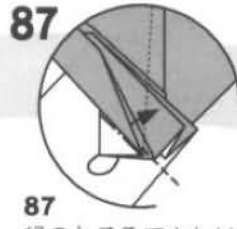

87
縁のところで中わり折り
Inside reverse fold
along the edge.

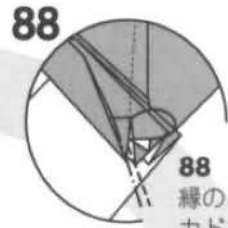

88
縁のところで
カドを内側に折る
Inside reverse fold
along the edge.

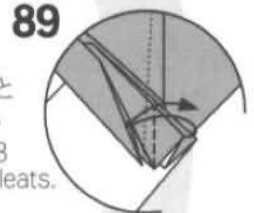

89
残りも83~88と
同じように折る
Repeat 83~88
on the other pleats.

92

92
○の部分のカドを
それぞれ75~91と
同じように折る
Repeat 75~91
on the left.

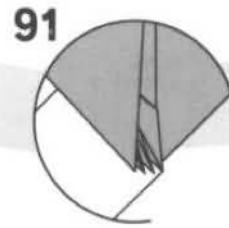
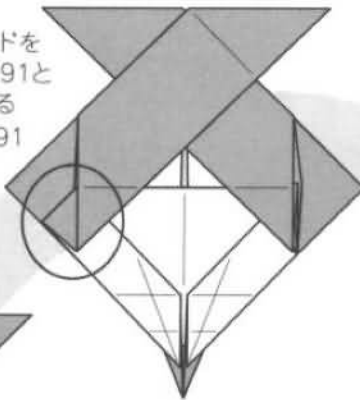

91

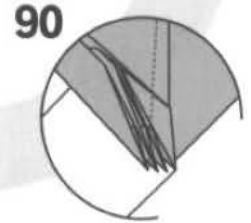

90

93

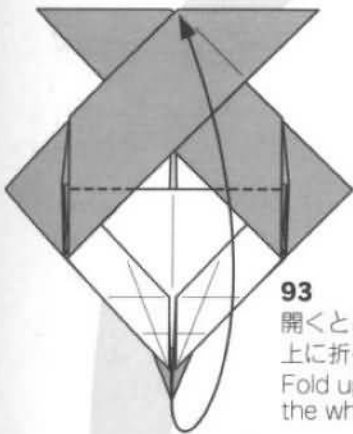

93
開くところでカドを
上に折る
Fold up along
the white edge.



97
縁と縁を
合わせて折る
Fold angle
bisectors.

94

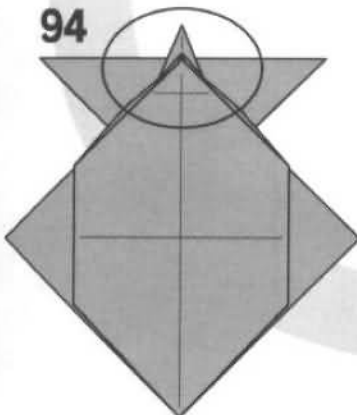

95

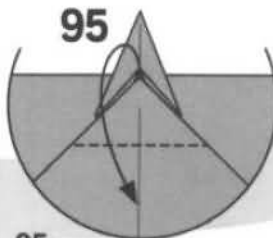

95
開くところでカドを
下に折る
Open folding down
as far as possible.

96



96
少し残してカドを上
に折る
Valley up, forming a
small pleat.

100

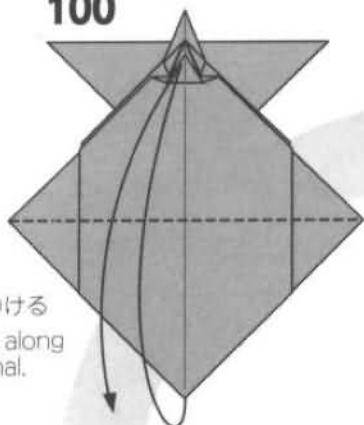

100
折り筋をつける
Precrease along
the diagonal.

101

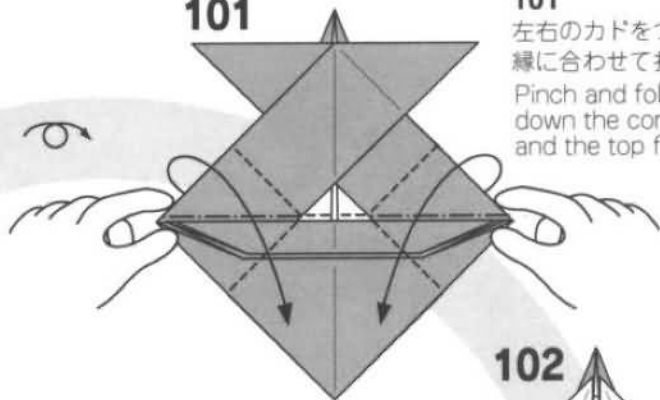

101
左右のカドをつまんで
縁に合わせて折る
Pinch and fold
down the corners
and the top flaps.

99



98



98
■の部分
すく下の内側に折り込む
Mountain folds along
the line connecting
the corners.

102

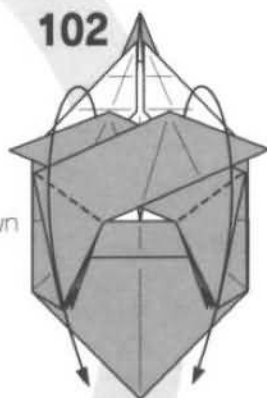

102
途中の図
Folding down
the flaps.

103

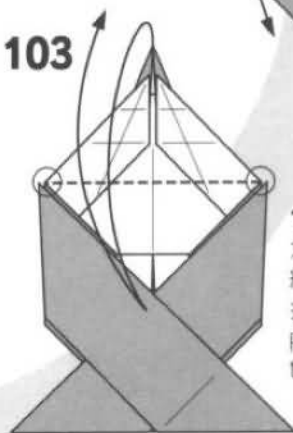

103
カドとカドを
結ぶ線で
折り筋をつける
Precrease corner
to corner.

104

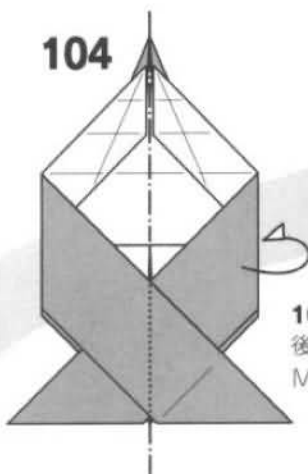

104
後ろへ半分に折る
Mountain fold in half.

105

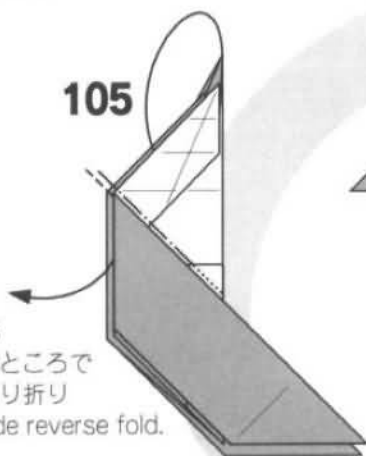

105
縁のところで
中わり折り
Inside reverse fold.

106



106
103でつけた折り筋と
縁を合わせて中わり折り
Inside reverse fold,
so that the precrease
made in 103 aligns with
the edge on the right.

107

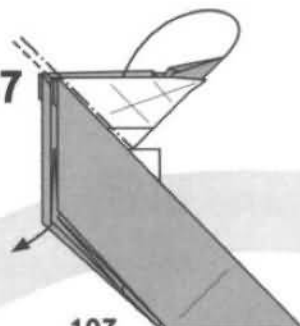

107
縁のところで
カドを内側に折る
Inside reverse
along the edge.

116
 縁と縁を合わせて
 内側のカドを
 内側に折る
 Inside reverse
 folds so that the
 edges align with
 the vertical lines.

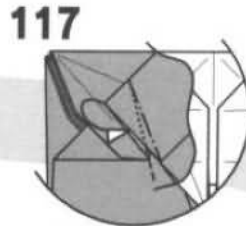
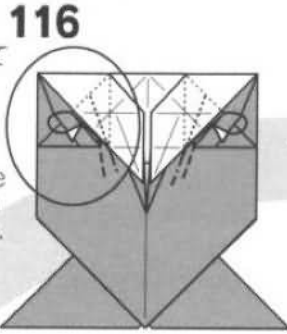

117
 内側を見た図
 反対側も同じ
 Inside view.
 Repeat on
 the right.

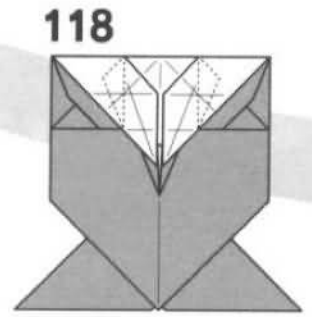

115
 途中の図
 The top part is
 folded down by
 folding 114.

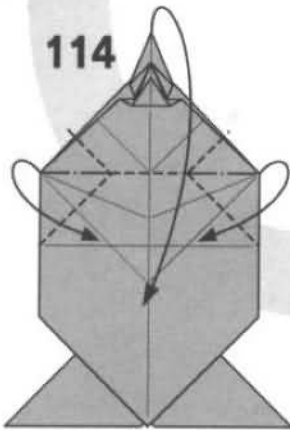

114
 つけた折り筋で
 左右のカドをつまんで
 折りまとめる
 Pinch and fold down
 the side corners.

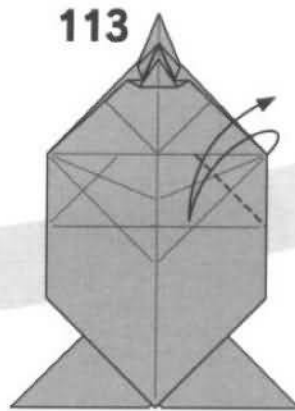

113
 反対側も111~112と同じ
 Repeat 111~112
 on the right.

この部分だけ
 折り筋をつける
 Precrease only
 this part.

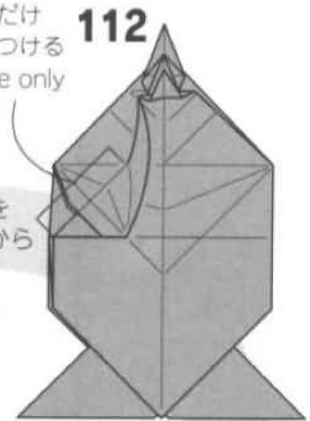

112
 折り筋を
 つけてから
 戻す
 Unfold.

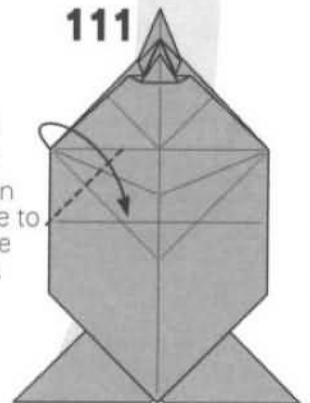

111
 縁と折り筋を
 合わせて折る
 Fold and align
 the side edge to
 the precrease
 in the middle.

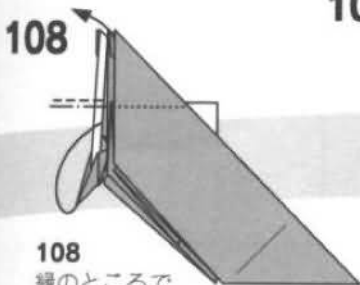

108
 縁のところで
 内側のカドを中わり折り
 Inside reverse
 along the
 hidden edge.

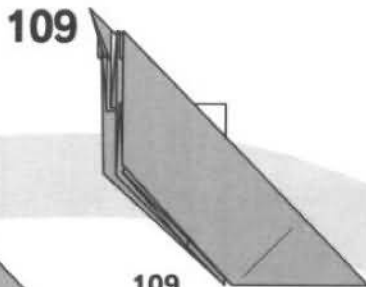

109
 しっかりと
 折り筋をつけて
 105の形まで戻す
 Unfold to 105.

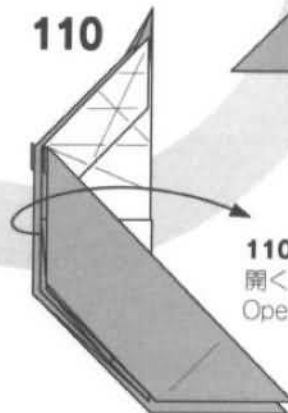

110
 開く
 Open up.

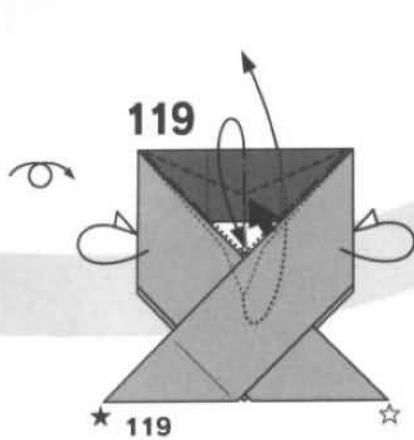

119
 ☆ 106でつけた折り筋で
 ■の部分押し込むように
 縁と縁を合わせて折りながら
 後ろへ半分に折る
 Mountain fold in half,
 while forming pleats on the top.

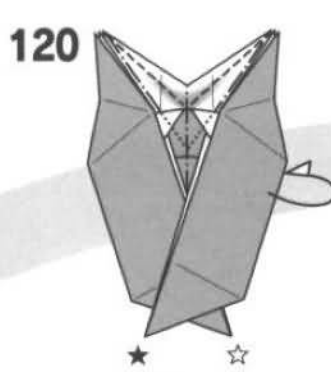

120
 ☆ ☆ 途中の図
 Assembling ...

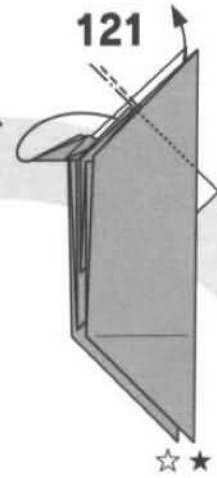

121
 ついている
 折り筋で
 内側のカドを
 中わり折り
 Inside reverse
 the inner corner
 using the
 precreases.

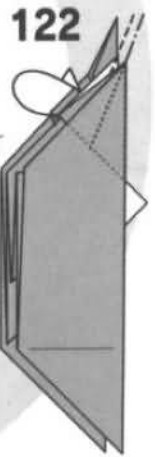

122
 内側のカドを
 縁と縁を合わせて
 内側に折る
 反対側も同じ
 Inside reverse
 fold edge to
 edge on the
 inner corners.

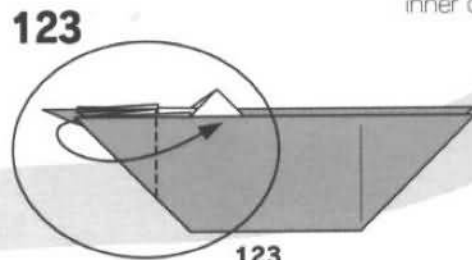

123
 開くところで
 カドを反対側に折る
 Open as far as possible.



124
 つられて
 持ち上がる部分を
 開いてつぶす
 Squash the part
 pulled up.

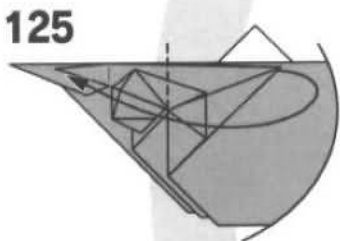

125
 カドを
 反対側に折る
 Fold back.



128
 しっかりと
 折り筋を
 つけてから戻す
 Fold back.

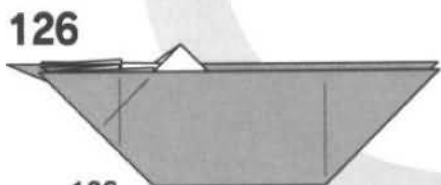

126
 反対側も 123~125と同じ
 Repeat 123~125 on
 the back.

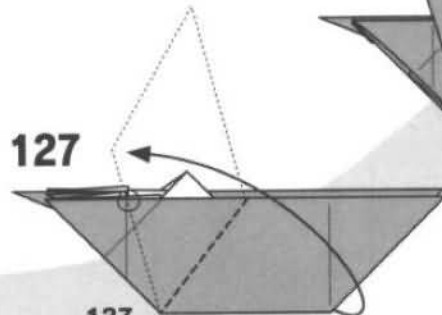

127
 ○の折り筋と縁を合わせて
 カドを斜めに折る
 Fold up so that the bottom edge
 reaches the circled intersection.

136



136
反対側も
127~135と同じ
Repeat 127~135
on the back.

137

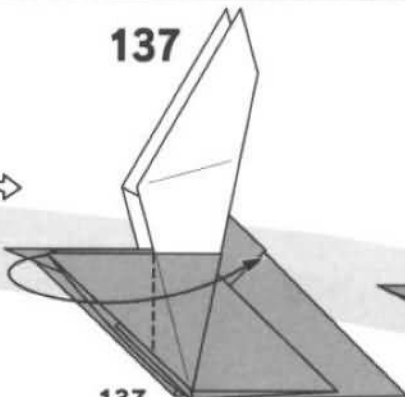

137
開くところで
カドを反対側に折る
反対側も同じ
Open as far as possible.
Repeat on the back.

138

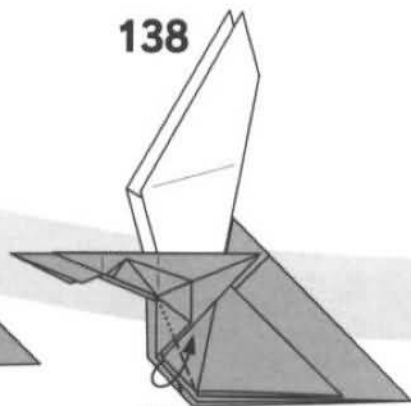

138
内側の1枚目の
カドを斜めに折る
Fold up the inner corner.

135

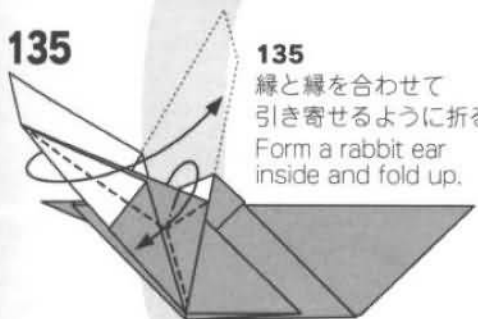

135
緑と緑を合わせて
引き寄せるように折る
Form a rabbit ear
inside and fold up.

134

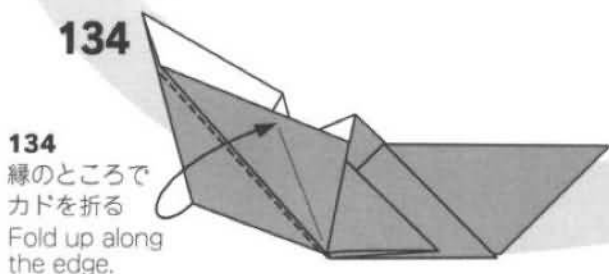

134
緑のところで
カドを折る
Fold up along
the edge.

133

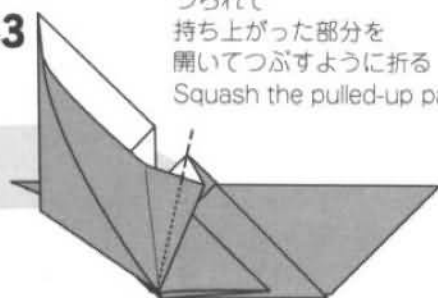

133
つられて
持ち上がった部分を
開いてつぶすように折る
Squash the pulled-up part.

129

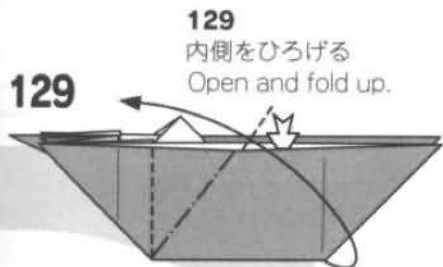

129
内側をひろげる
Open and fold up.

132

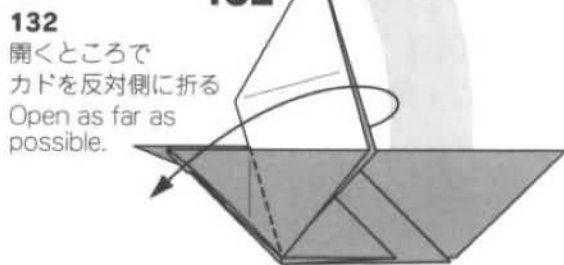

132
開くところで
カドを反対側に折る
Open as far as
possible.

130

130

黒矢印の部分を
押し込むようにして
ひっくり返す
Push the arrowed part and sink.

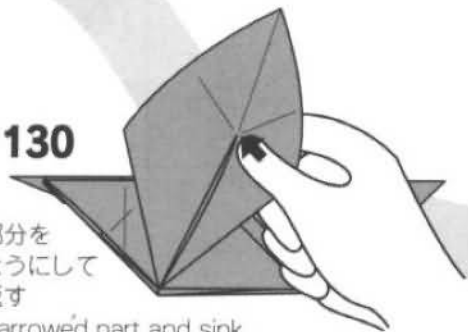

131

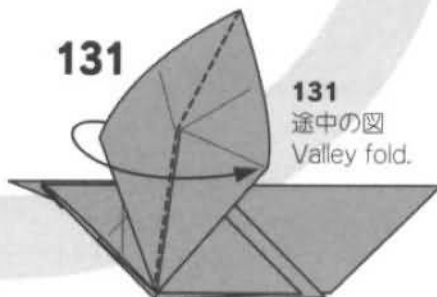

131
途中の
Valley fold.

139

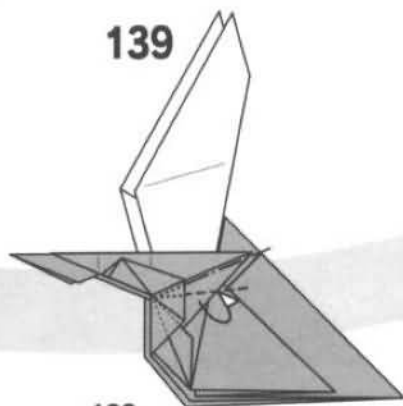

139
縁のところで後ろへ引き寄せ折り
Mountain fold along the edge
and stretch the hidden layer.

140

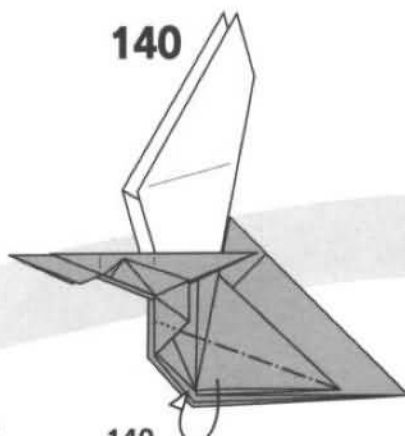

140
カドを内側に折る
Mountain fold the
inner corner.

141

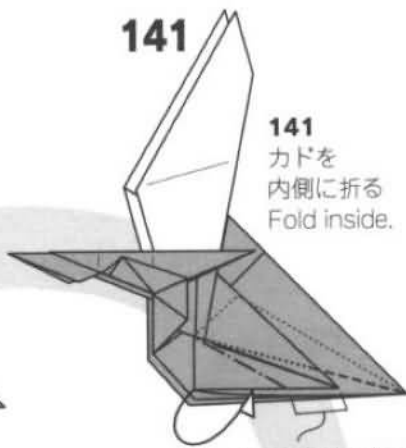

141
カドを
内側に折る
Fold inside.

ここをあけて折る
Leave some length
of an edge intact.

144

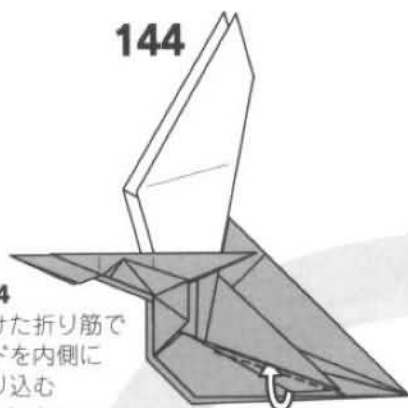

144
つけた折り筋で
カドを内側に
折り込む
Tuck the corner
inside.

143

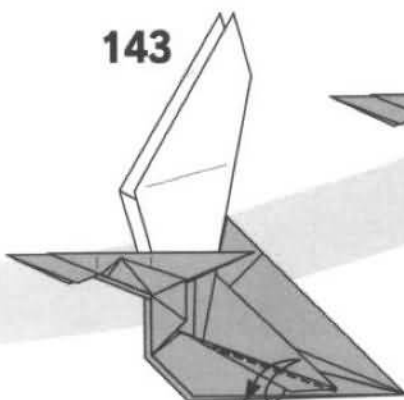

143
縁のところで
折り筋をつける
Precrease along
the edge.

142

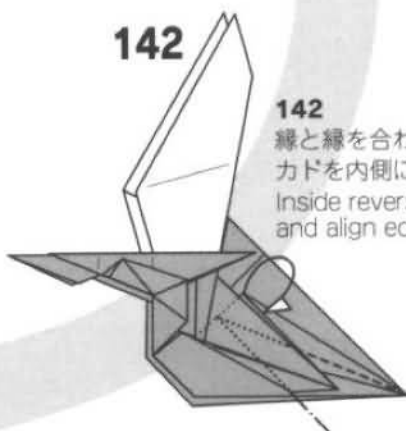

142
縁と縁を合わせて
カドを内側に折る
Inside reverse fold
and align edges.

145

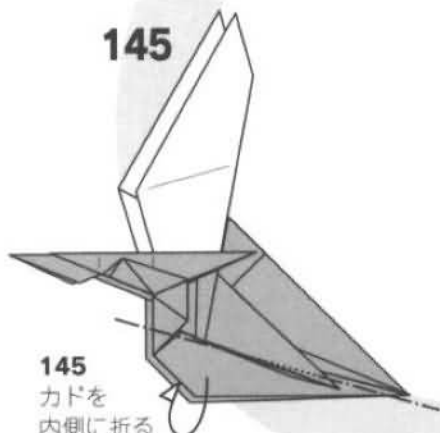

145
カドを
内側に折る
Tuck inside.

146

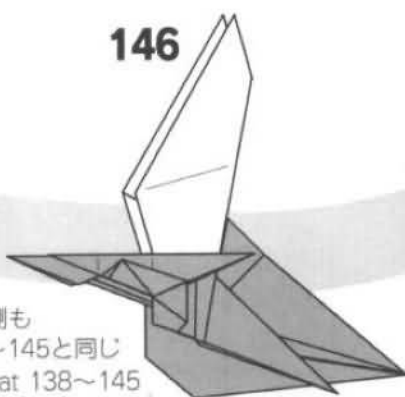

146
反対側も
138~145と同じ
Repeat 138~145
on the back.

147

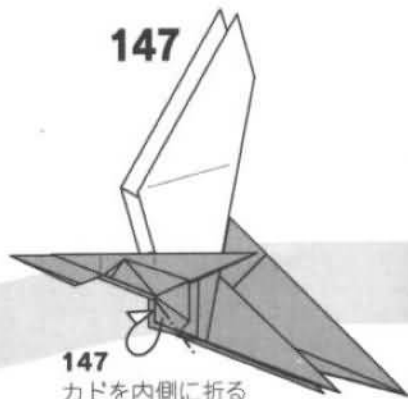

147
カドを内側に折る
反対側も同じ
Tuck the corner inside.

155

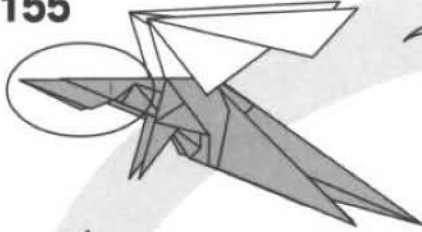

156

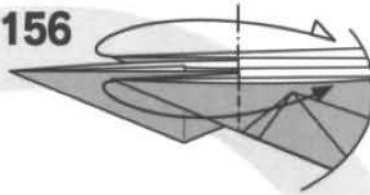

156
それぞれカドを
反対側に折る
Fold the corners
to the right.

154

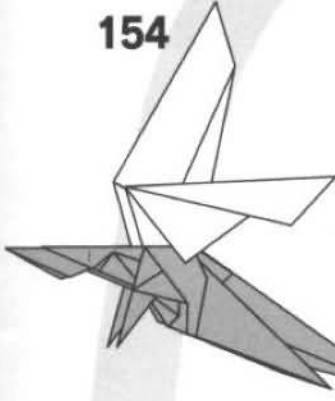

154
反対側も
151~153と同じ
Repeat 151~153
on the back.

157

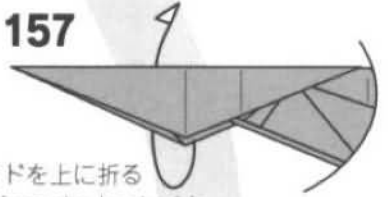

157
下のカドを上
に折る
Open from the
back side..

158

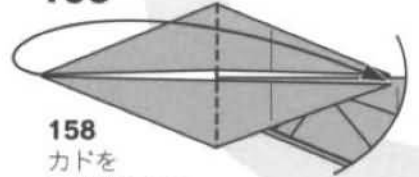

158
カドを
反対側に折る
Swivel to the
right.

153

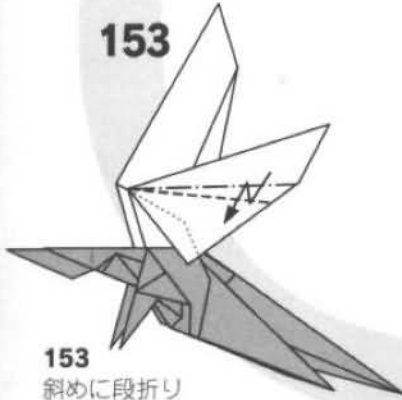

153
斜めに段折り
Form a pleat.

152

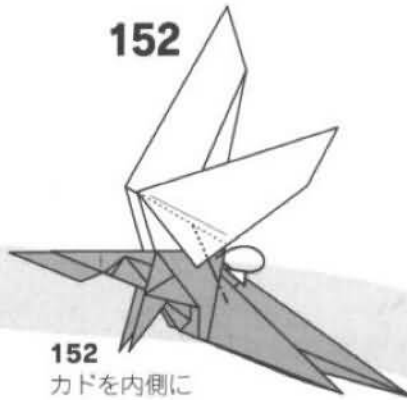

152
カドを内側に
折り込む
Tuck the corner
inside and lock.

151

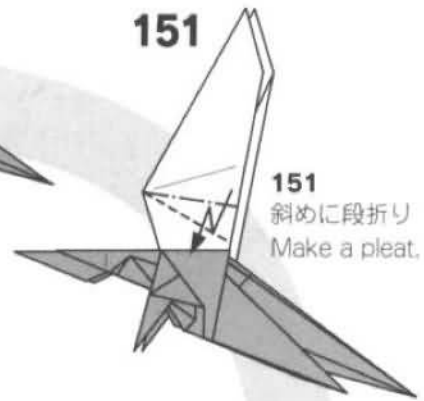

151
斜めに段折り
Make a pleat.

148

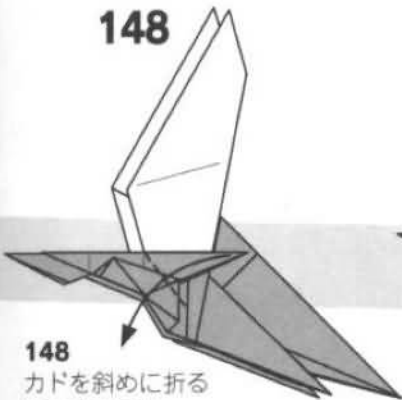

148
カドを斜めに折る
反対側も同じ
Fold down the
front leg.

149

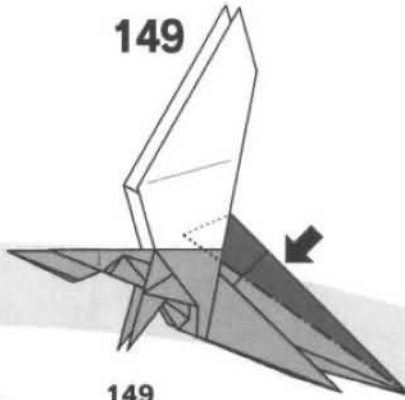

149
■の部分
を沈め折り
Sink the
darkened part.

150

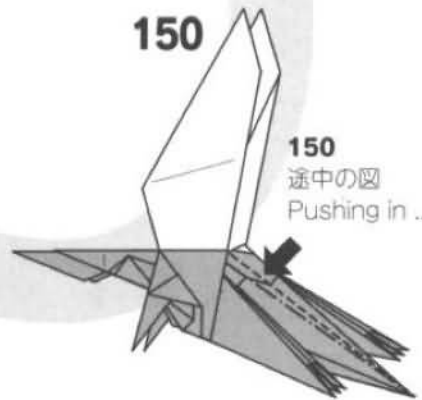

150
途中の図
Pushing in ...

169

169
内側を通して
カドを斜めに折る
反対側も同じ
Fold inside.
Repeat on the back.



170

170
斜めに段折り
反対側も同じ
Form pleats.
Repeat on the back.

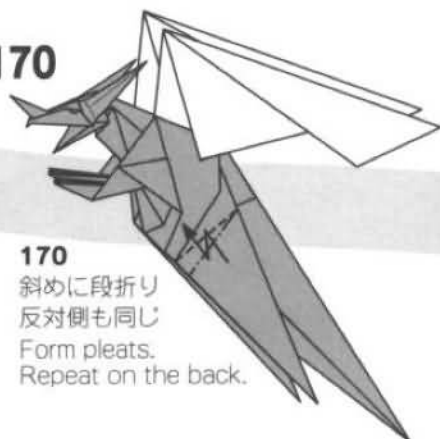

168

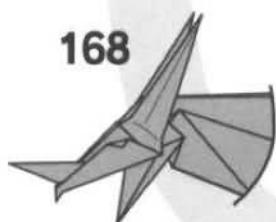

167

167
かぶせるように
斜めに段折り
Form pleats and
bend the neck.

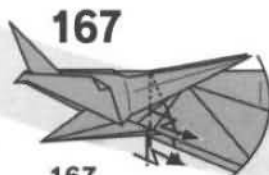

159

159
カドを少し残して
反対側に折る
Fold back, forming
a small pleat.

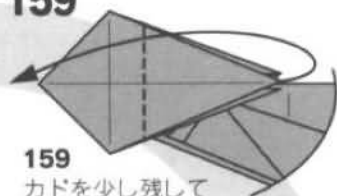

166

166
カドを少し中わり折り
Inside reverse on the
tip of the nose.

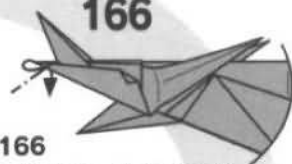

160
カドを後ろへ折る
Closing back.

160



165

165
カドをつまんで
形を整える
反対側も同じ
Pinch and form horns.

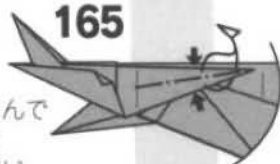

161

161
かぶせ折り
Outside reverse fold.

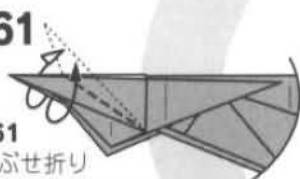

164

164
内側のカドを
引き出して
あごを作る
Pull down the inner
corner to form a jaw.

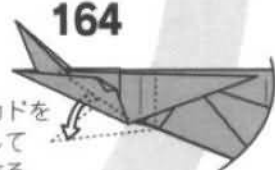

162

162
カドと縁を
合わせて折る
反対側も同じ
Fold angle bisectors
on the front and the back.

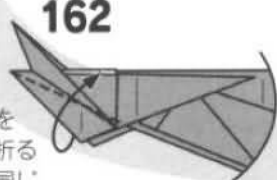

163

163
カドを少し折る
反対側も同じ
Fold down the tips
of the corners.

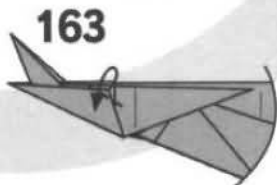

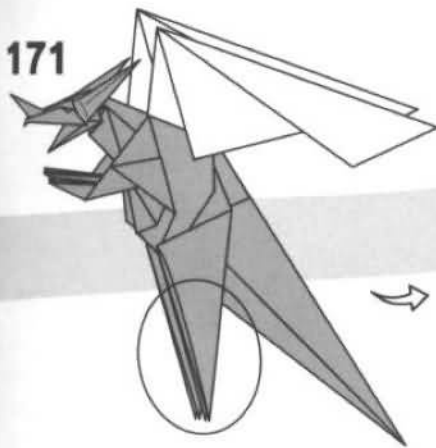

171

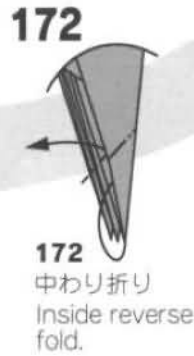

172

172
中わり折り
Inside reverse fold.

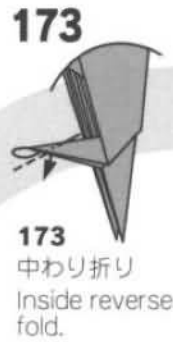

173

173
中わり折り
Inside reverse fold.



174

174
残りのカドも
172~173と同じ
Repeat 172~173
on the other
fingers.



175

175
反対側も
172~174と同じ
Repeat 172~174
on the other foot.

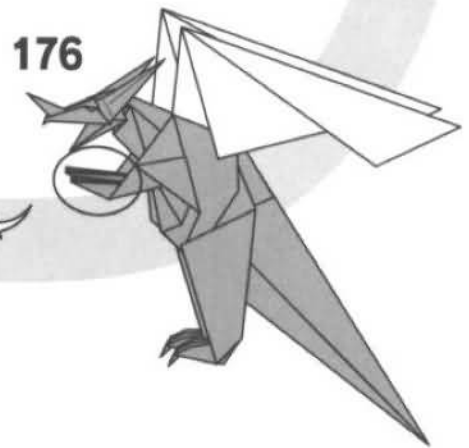

176



177

177
指をひろげて
表情をつける
Open the palm
and shape it.



178

178
反対側も同じ
Repeat on the
other hand.

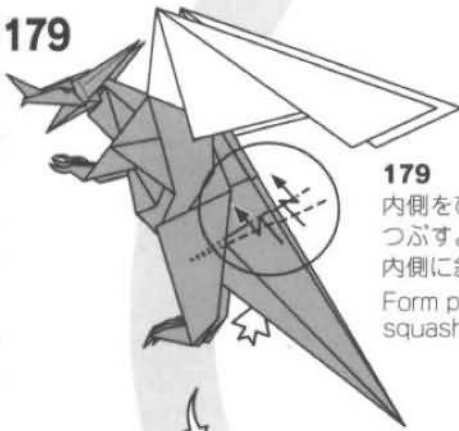

179

179
内側をひろげて
つぶすように
内側に斜めに段折り
Form pleats while
squashing inside,

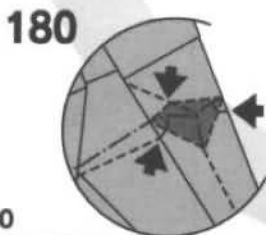

180

180
内側を見た図
沈め折りした部分を平らにして
黒矢印の部分押し込んで
つぶすように折る
... like this.

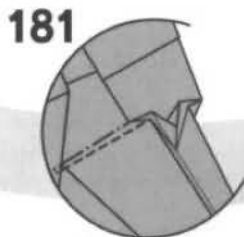

181

181
途中の図
Finished tail.

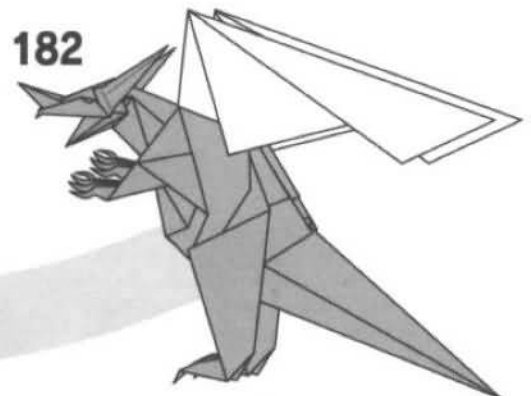

182

できあがり
Model Completed

鳥獣戯画の蛙

A Frog in "Choju Giga (Frolicking Birds and Animals)"

指のある造形は、もちろん前川淳さんの「悪魔」がインスピレーションの源泉です。本書「カニ」の手法を指表現に応用しました。漫画の原点とも言われる鳥獣戯画の蛙は指先の表現が何とも滑稽さを強調していて、本作を作ってみて造形上の指表現の威力を実感しました。

Inspired by Maekawa's famous "Devil", fingers in this work is an application of my own method (see "Crab"). The frog described here is a character in the first manga in Japan.



Created 1982 Paper 複合作品・2枚：2 pieces

[上半身] Upper Part of the Body

1
カドを中心に合わせて
折り筋をつける
Fold the corners
to the center.

2
カドを折り筋に
合わせて
折り筋をつける
Fold the corners to the
intersection made in 1.
on the far side.

3
2でつけた
折り筋を
中心に合わせる
ように段折り
Fold pleats along
the center line.

4
カドを縁に
合わせて折る
Fold and align corners
to the inner colored
edges.

5
後ろへ
半分に折る
Mountain fold.

6

7
縁のところで
折り筋をつける
Precrease along
the edge.

8
内側をひろげて
つぶすように折る
Open up and squash.

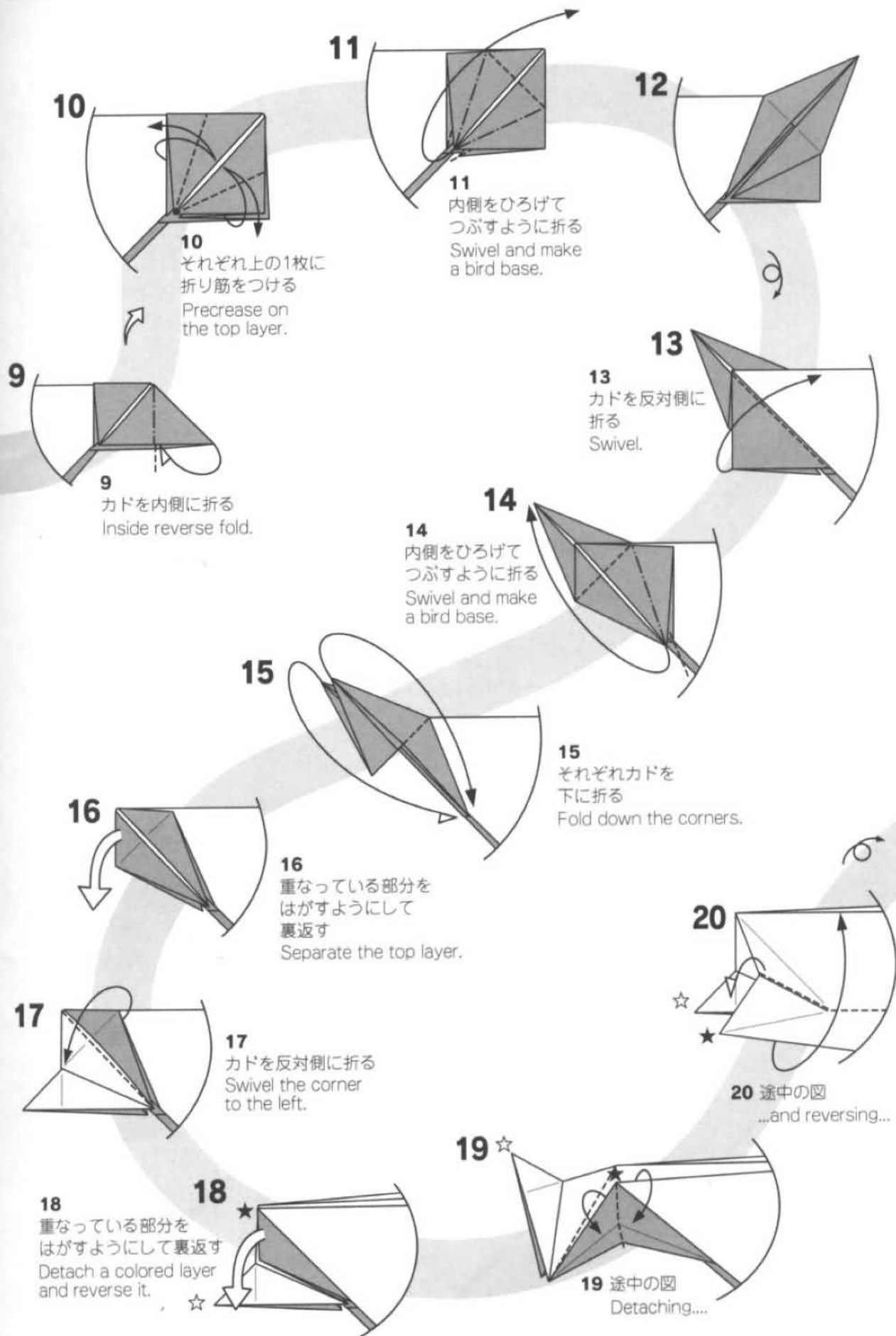

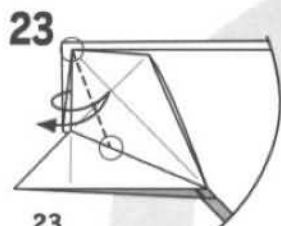

23
縁を折り筋に合わせて
折り筋をつける
Precrease along
the angle bisector.

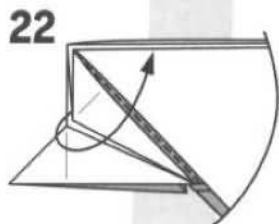

22
カドを反対側に折る
Swivel the top layer
to the right.

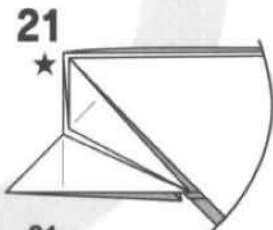

21
★
反対側も17~20と同じ
Repeat 17~20
on the back.

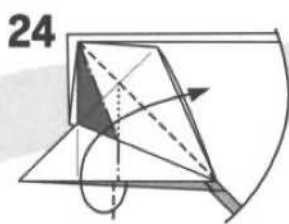

24
内側をひろげて
■の部分
つぶすように折る
Open and squash
the lower corner and
the darkened part.

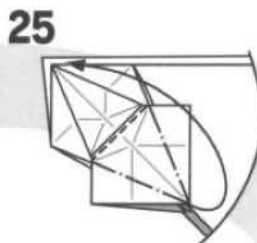

25
内側をひろげて
つぶすように折る
Swivel and fold
like a bird base.

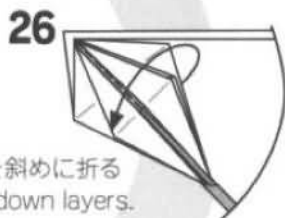

26
カドを斜めに折る
Fold down layers.

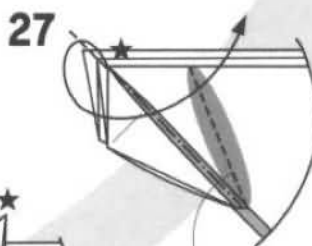

27
カドをつまむ
ように折る
Pinch and pull
the starred
corner to the
right.



28
★
縁を
折り筋に合わせて
折り筋をつける
Fold along an angle
bisector.

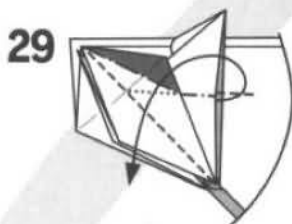

29
内側をひろげて■の部分
つぶすように折る
Open and squash
the lower part
and the colored part.

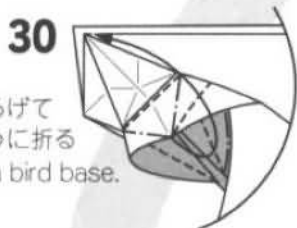

30
内側をひろげて
つぶすように折る
Fold like a bird base.



31
反対側も
22~30と同じ
Repeat 22~30
on the back.

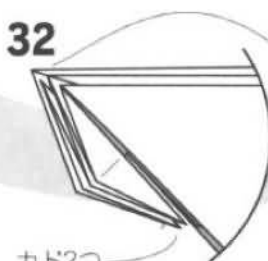

32
カド4つ
(真ん中の2つが重なっている)
Note that there are
four corners on the top,
of which two overlap
each other,
and two corners on the bottom.

33
反対側も7~32と同じ
Repeat 7~32 on the right side.

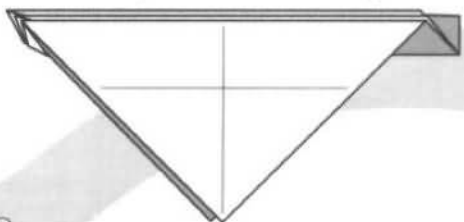

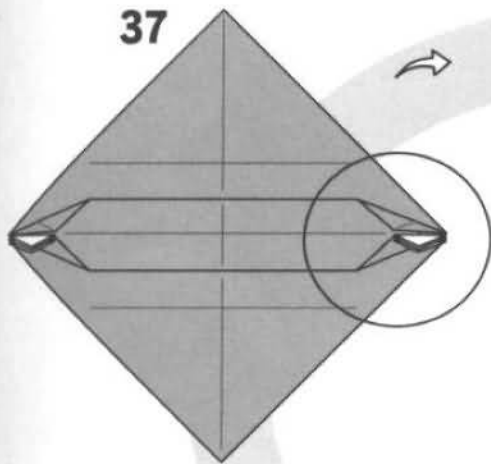

37

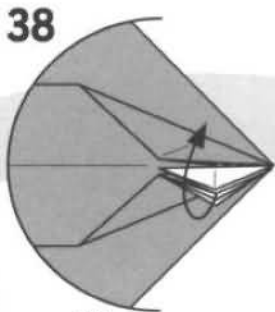

38

38
カドを2枚まとめて
上に折る
Fold up two white
layers.

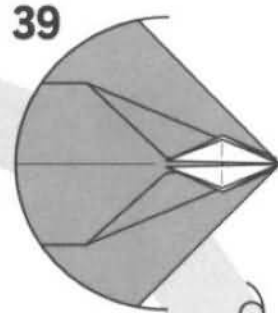

39

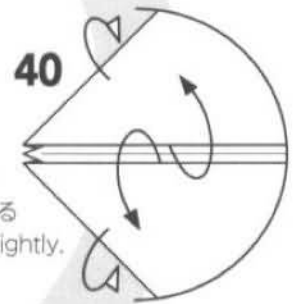

40

40
内側を
ひろげる
Open lightly.

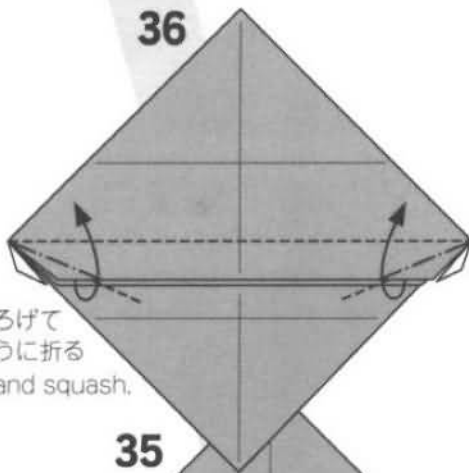

36

36
内側をひろげて
つぶすように折る
Fold up and squash.

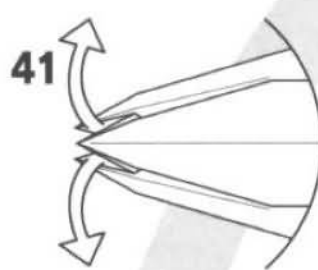

41

41
カドをつまんで
かるくひろげる
Pinch the two
corners and show
the innermost layer
of corners.

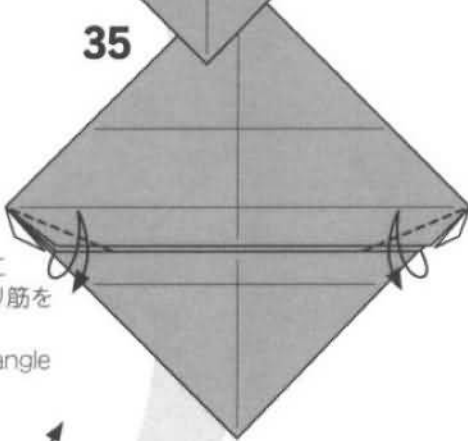

35

35
線を折り筋に
合わせて折り筋を
つける
Fold along angle
bisectors.

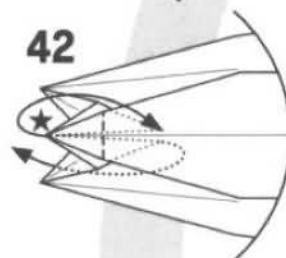

42

42
上のカドを反対側に
折りながら
下のカドを起こす
ように折る
Swiveling the top
corner to the left,
pull up the lower
corner.

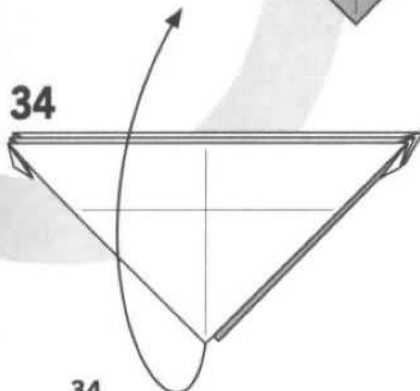

34

34
上の1枚をひろげる
Fold up the top layer.

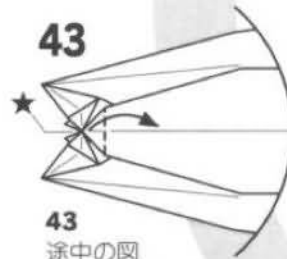

43

43
途中の図
Swiveling...

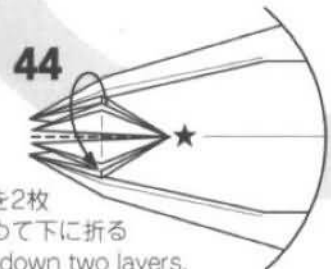

44

44
カドを2枚
まとめて下に折る
Fold down two layers.

53
カドとカドを
合わせて
折り筋を
つける
Precrease on
the diagonal.

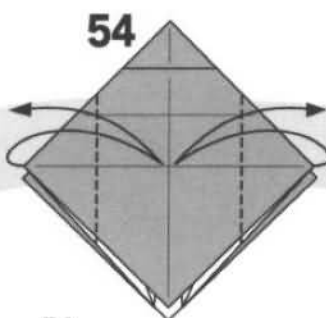
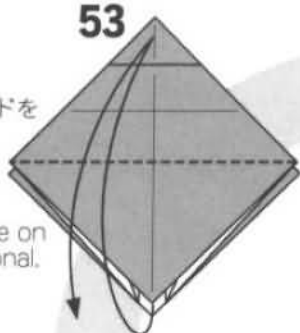

54
カドを中心に合わせて
折り筋をつける
Precrease side corners
to the center.

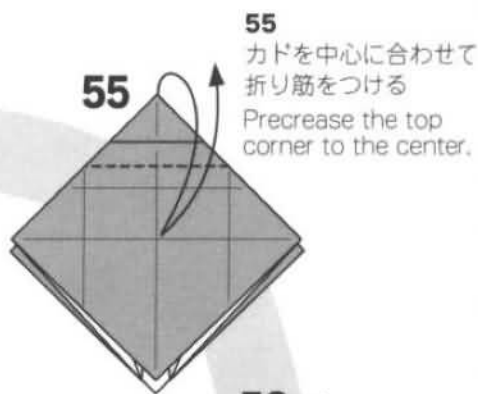

55
カドを中心に合わせて
折り筋をつける
Precrease the top
corner to the center.

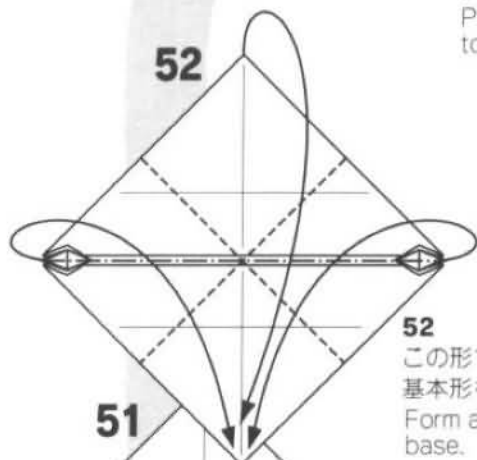

52
この形で正方
基本形を折る
Form a preliminary
base.

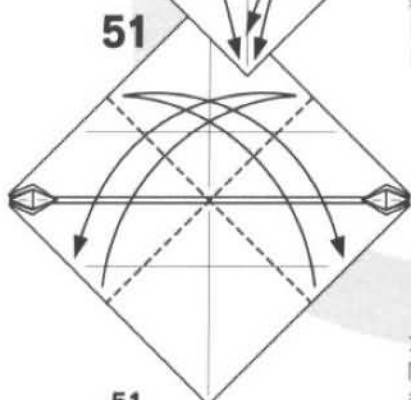

51
縁と縁を合わせて
折り筋をつける
Precrease along
the center lines.

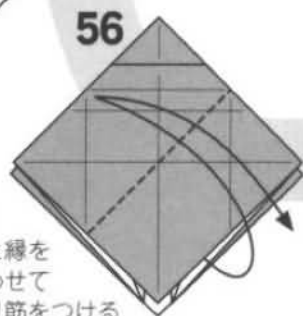

56
縁と縁を
合わせて
折り筋をつける
Precrease along
the center line.

カド5つ
Note that there
are five fingertips.

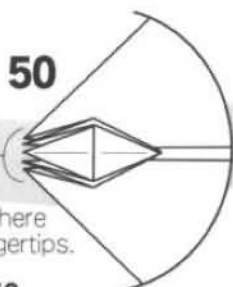

50
反対側も38~48と同じ
Repeat 38~48 on the left.

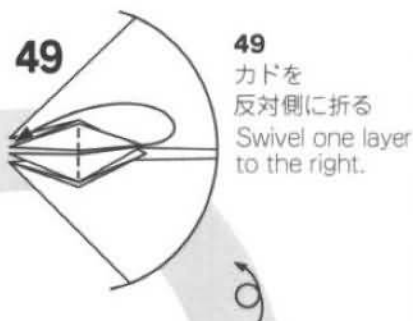

49
カドを
反対側に折る
Swivel one layer
to the right.

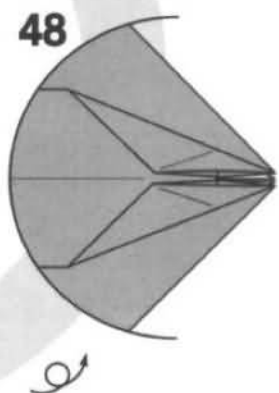

48

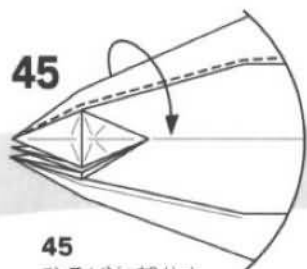

45
ひろげた部分を
かぶせるようにして戻す
Fold back the opening
on the top.

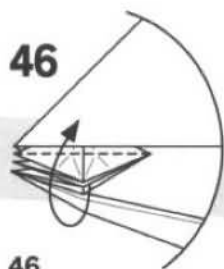

46
カドをかぶせるように
上へ折る
Fold back two corners up.

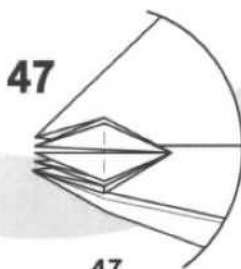

47
反対側も44~46と同じ
Repeat 44~46 on
the lower side.

58
つけた折り筋を使って
内側をひろげて
つぶすように折る
Fold using the
precreases and
squash.

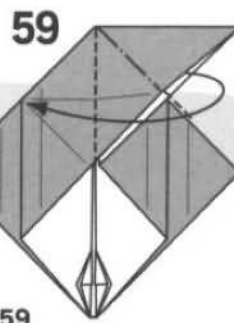
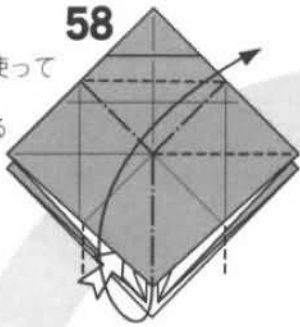

59
内側をひろげて
つぶすように折る
Open and squash.

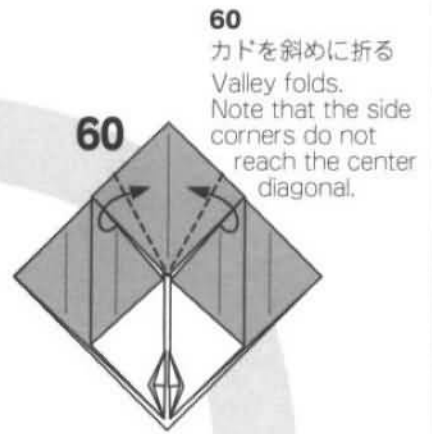

60
カドを斜めに折る
Valley folds.
Note that the side
corners do not
reach the center
diagonal.

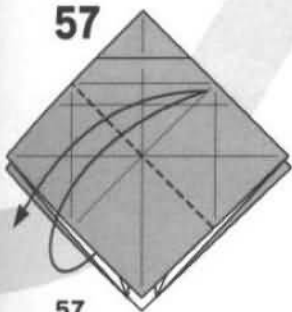

57
縁と縁を合わせて
折り筋をつける
Precrease along
the center line.

61
縁と縁を合わせて
折り筋をつける
Precrease along
the edges.

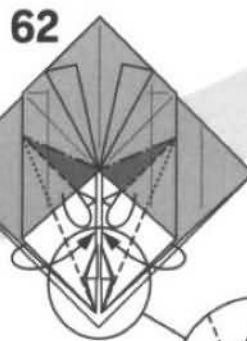
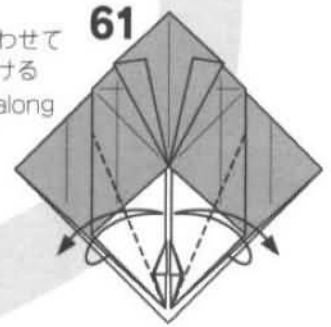

62
■の部分の内側に折る
Tuck the darkened parts
to the inside.

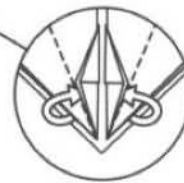

縁をすき間に
差し込む
Tuck the folded
edges under the
white fingertips.

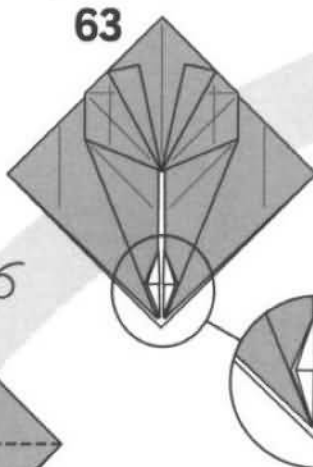

63

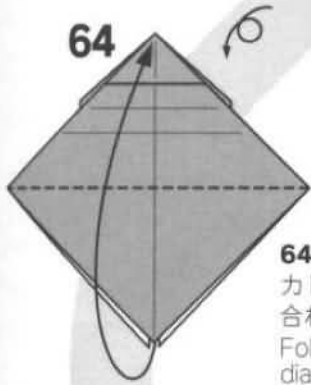

64

64
カドとカドを
合わせて折る
Fold up
diagonally.

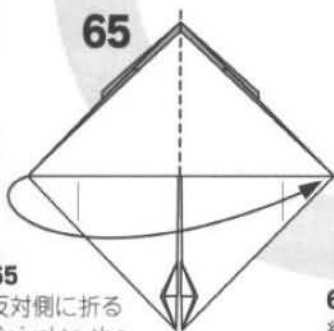

65

65
反対側に折る
Swivel to the
right.

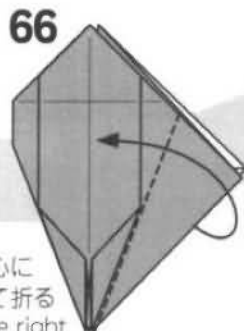

66

66
縁を中心に
合わせて折る
Fold the right
edge to the center.

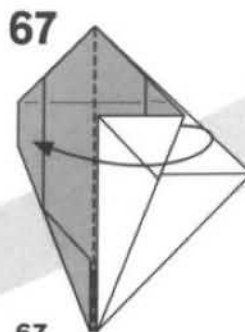

67

67
カドを反対側に折る
Swivel to the left.

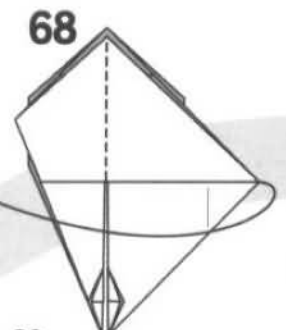

68

68
反対側も65~67と同じ
Repeat 65~67 on the
right side.

[下半身]
Lower Part of
the Body

1

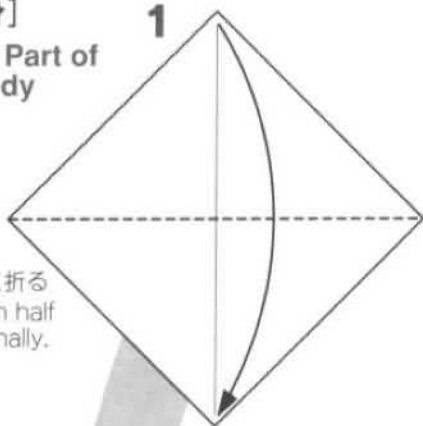

1
三角に折る
Fold in half
diagonally.

2

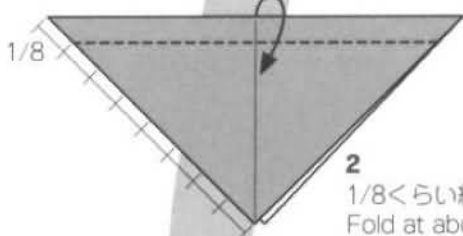

2
1/8くらい縁を折る
Fold at about one
eighth of the height.

3

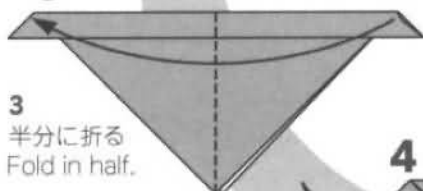

3
半分に折る
Fold in half.

4

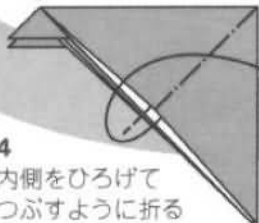

4
内側をひろげて
つぶすように折る
Open and squash.

8

カドを中心に合わせて
折り筋をつける
Precrease side
corners to the
center.

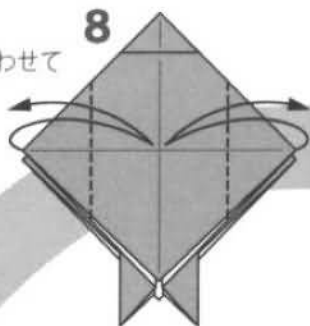

7

7
カドとカドを
合わせて
折り筋をつける
Precrease corner
to corner.

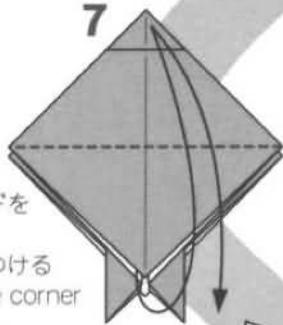

6

6
上のカドと
下のカドを
それぞれ
反対側に折る
Swivel on the top
and bottom,
to different directions.

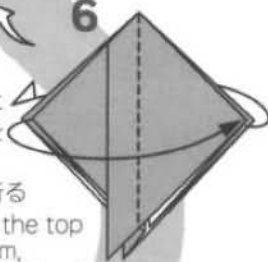

5

5
反対側も
同じように折る
Repeat on the
back.

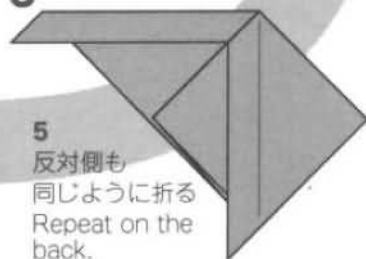

69



70

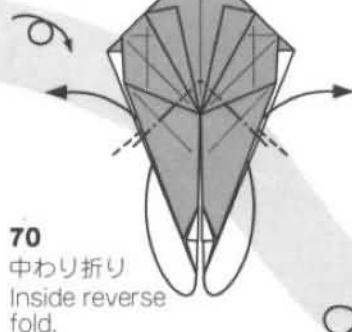

70
中わり折り
Inside reverse
fold.

71

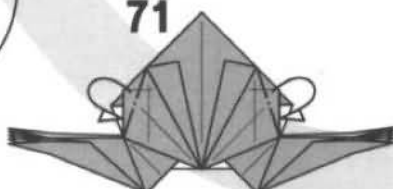

71 カドを内側に折る
Mountain folds.

73



[上半身]のできあがり
[Upper Part] Completed

72



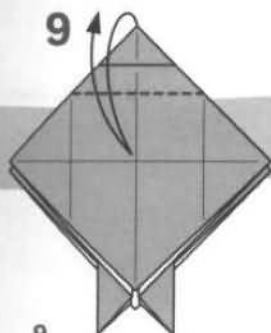

9
カドを中心に合わせて
折り筋をつける
Precrease the top
corner to the center.

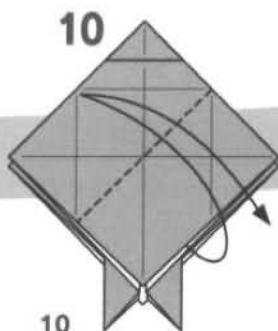

10
縁と縁を合わせて
斜めに折り筋をつける
Precrease edge to
edge.

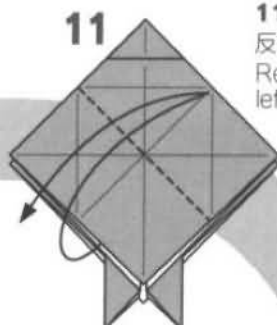

11
反対側も同じ
Repeat on the left side.

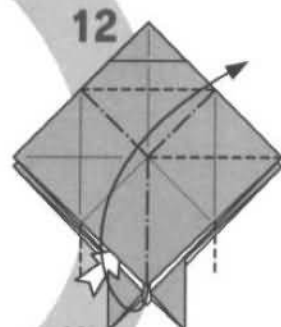

12
つけた折り筋を使って
内側をひろげて
つぶすように折る
Fold using preceases
and squash.

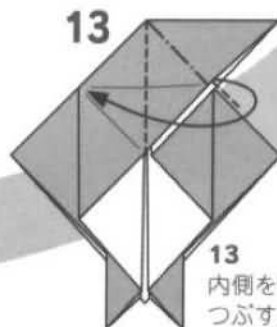

13
内側をひろげて
つぶすように折る
Open and squash.

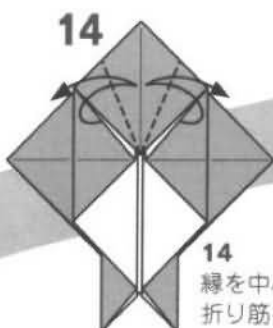

14
縁を中心に合わせて
折り筋をつける
Precrease so that
the lower side edges
align with the center
diagonal.

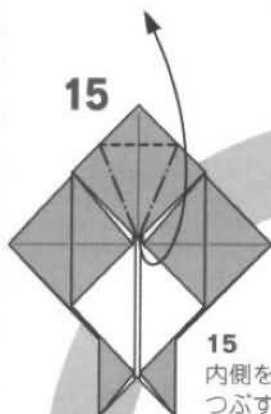

15
内側をひろげて
つぶすように折る
Swivel and
form a bird base.

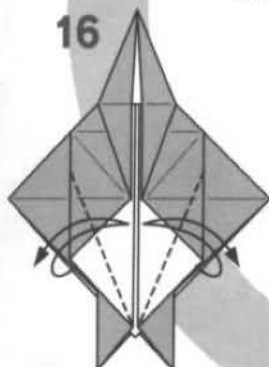

16
縁と縁を合わせて
折り筋をつける
Precrease so that
the lower edges
align with the
center line.

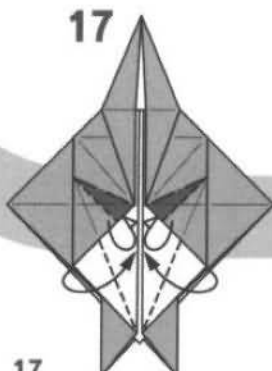

17
■の部分の内側に折る
Tuck the darkened part inside.

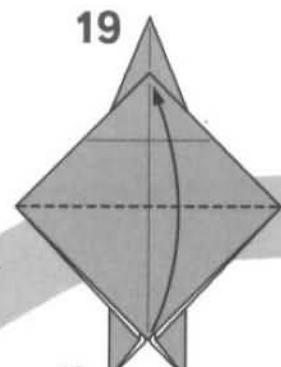
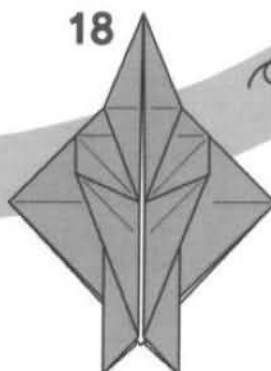

19
カドとカドを
合わせて折る
Fold up diagonally.

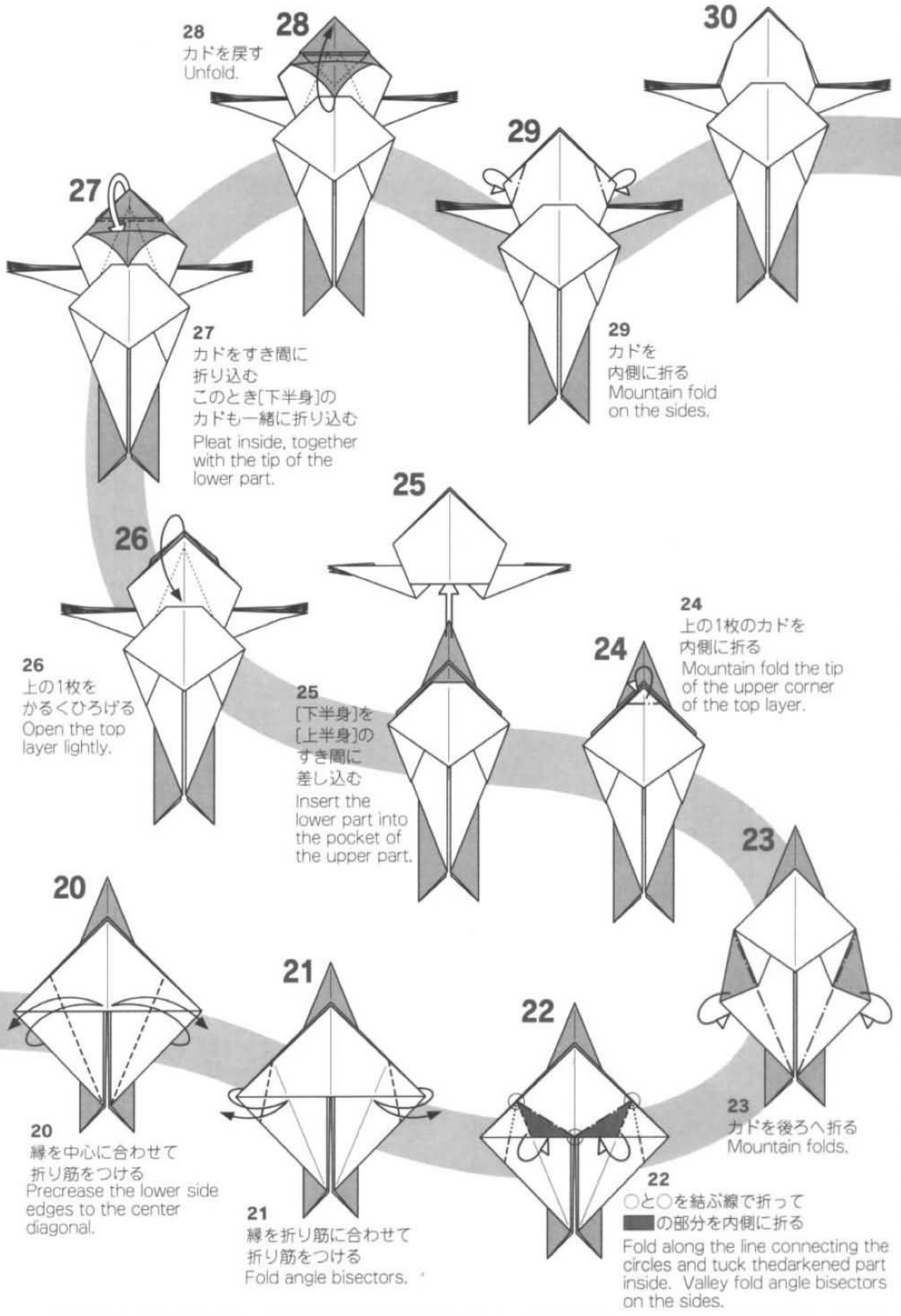

28
カドを戻す
Unfold.

30

27

27
カドをすき間に
折り込む
このとき[下半身]の
カドも一緒に折り込む
Pleat inside, together
with the tip of the
lower part.

29

29
カドを
内側に折る
Mountain fold
on the sides.

26

25

25
[下半身]を
[上半身]の
すき間に
差し込む
Insert the
lower part into
the pocket of
the upper part.

24
上の1枚のカドを
内側に折る
Mountain fold the tip
of the upper corner
of the top layer.

26
上の1枚を
かるくひろげる
Open the top
layer lightly.

24

23

23
カドを後ろへ折る
Mountain folds.

20

21

21
罫を折り筋に合わせて
折り筋をつける
Fold angle bisectors.

22

22
○と○を結ぶ線で折って
■の部分の内側に折る
Fold along the line connecting the
circles and tuck the darkened part
inside. Valley fold angle bisectors
on the sides.

20
罫を中心に合わせて
折り筋をつける
Precrease the lower side
edges to the center
diagonal.

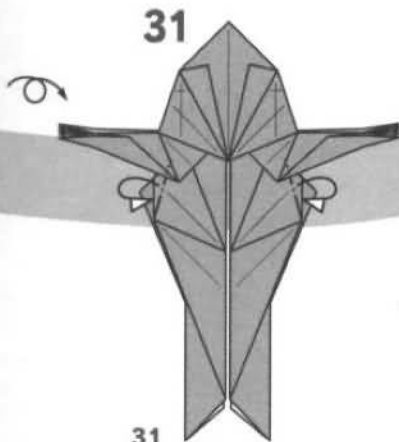

31
カドを内側に折る
Fold the corners of the body inside.

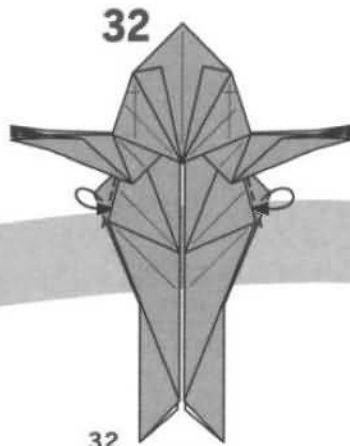

32
カドを内側に折る
Repeat on the other side.

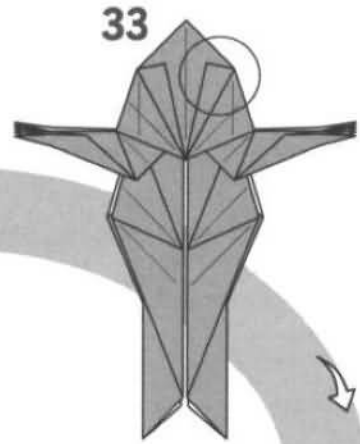

34
側をひろげて
つぶすように折る
Open and squash.

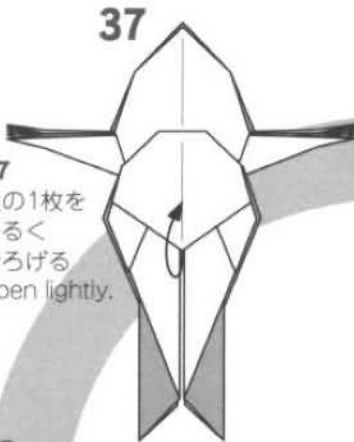

37
上の1枚を
かるく
ひろげる
Open lightly.

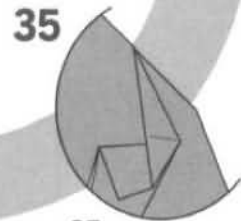
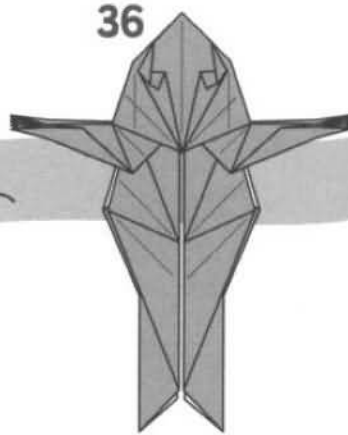

35
反対側も同じ
Repeat on the left side.

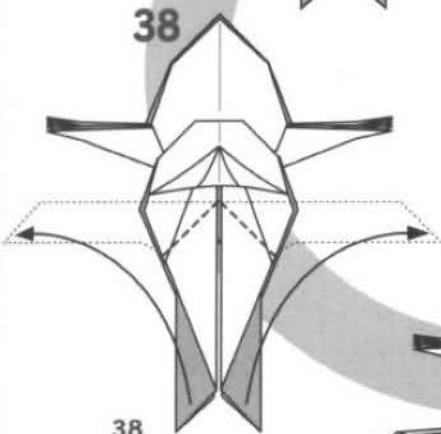

38
カドを横に
ひろげるように折る
Fold up the rear legs.

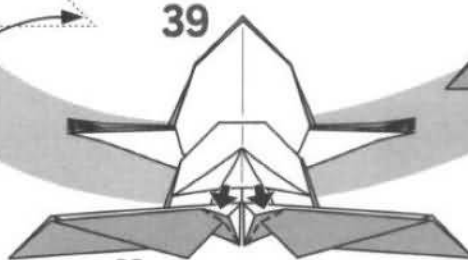

39
つられて持ち上がった部分を
つぶすように折る
Squash the small part
between the rear legs.

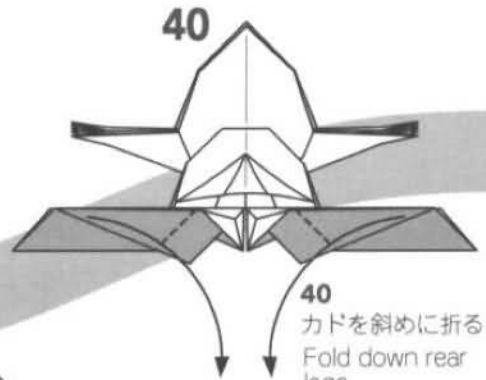

40
カドを斜めに折る
Fold down rear
legs.

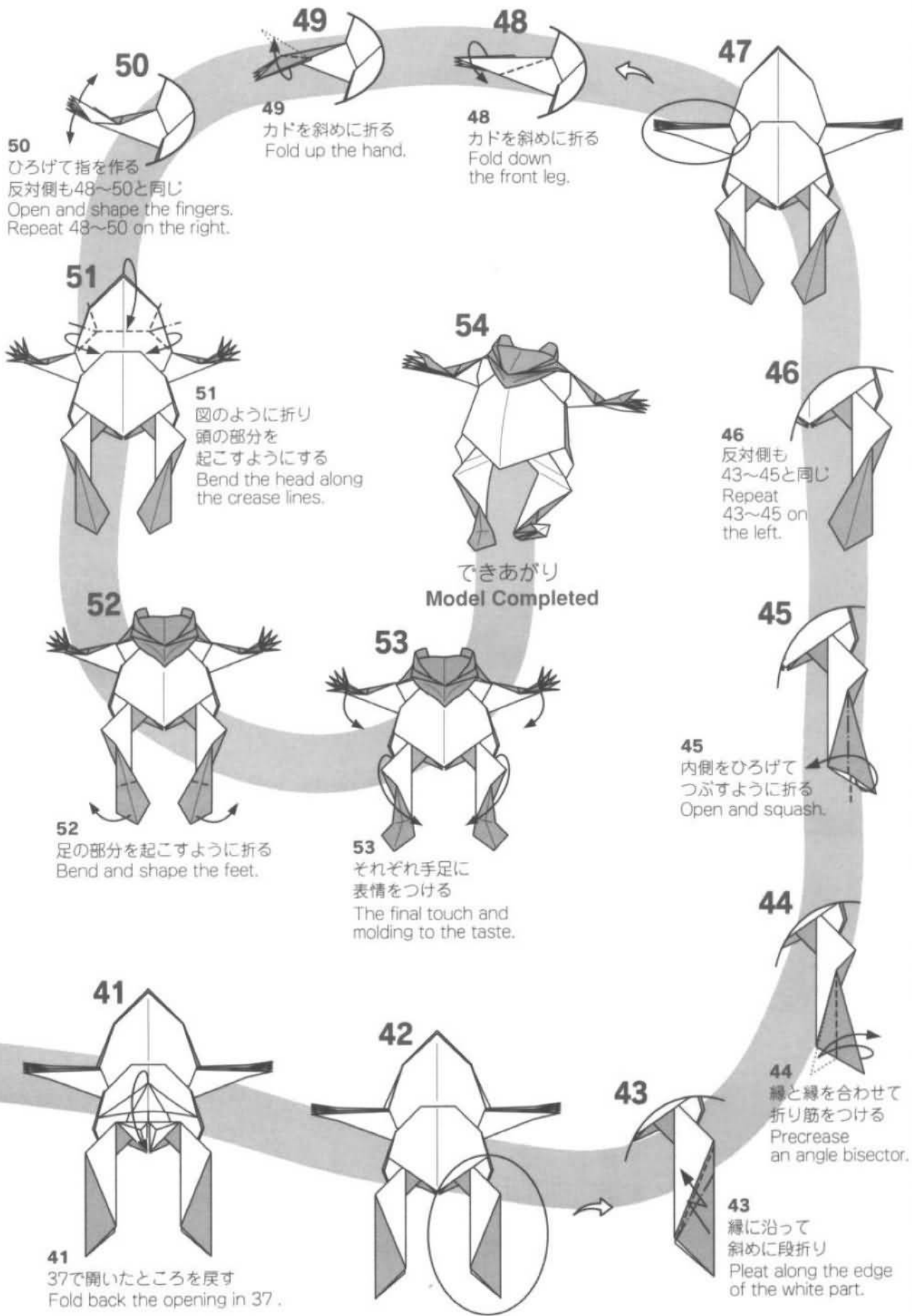

ウサギ

Rabbit

“ちょっと振り返る動物”3種(本作・カンガルー・パンダ)は、ほぼ同時期に創作したものです。イラストチックな仕上がりを目指したのに加え、複合作品を作るにあたっての、ささやかな狙いを定めました。複合作品は角の数を容易に揃える手段と見る傾向がありますが、本連作に対する作者の思いは違うところにありました。

A series of three animals turning back (Rabbit, Kangaroo, and Panda) are created at about the same time. Besides their caricaturistic appearances, I was thinking of something new when I decided that I would make them modular. (Continued ...)



Created 1982 Paper 複合作品・2枚: 2 pieces

[体] Body

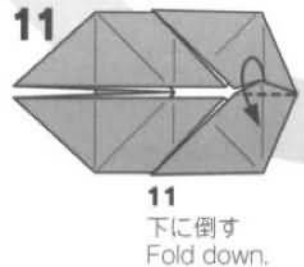
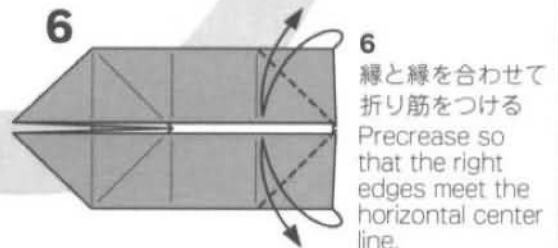
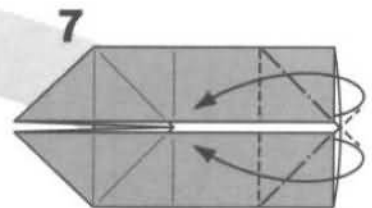
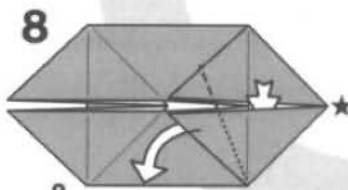
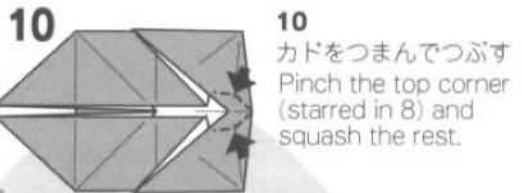
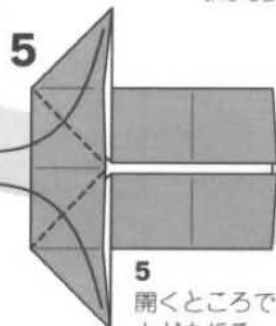
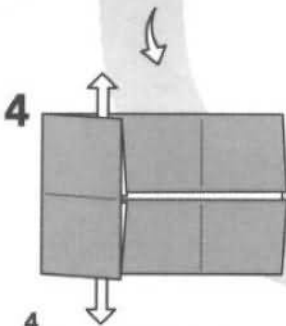
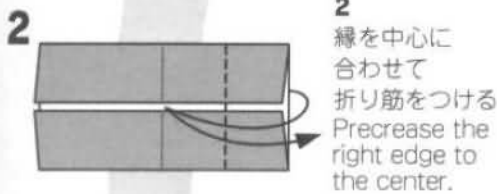
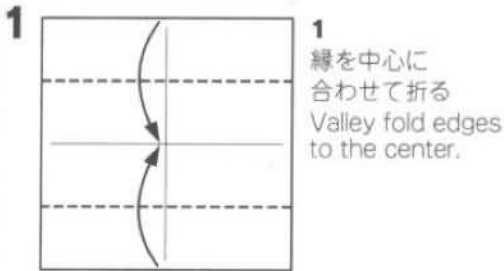

カドから少し離れた
ところで中わり折り
Inside reverse fold
the inner corner.
Leave some length
untouched in the rear.

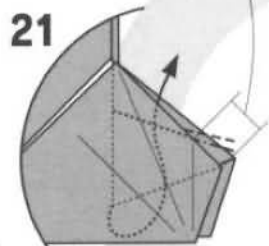

21
内側のカドを
中わり折りして
少し立体的にする
The outcome will become
three-dimensional.

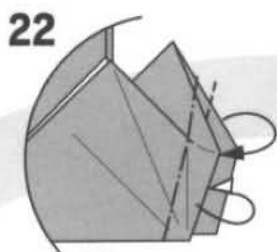

22
カドを内側に折る
Mountain fold the rear.
Repeat on the other side.

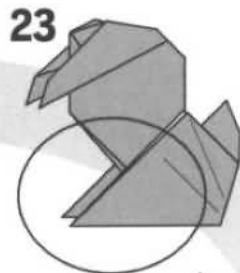

24
後ろへ斜めに折る
Mountain fold to
form the foot.

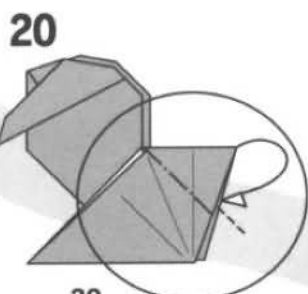

20
カドを内側に折る
Inside reverse fold.



19
カドを内側に折る
Mountain fold the
tips of the corners.

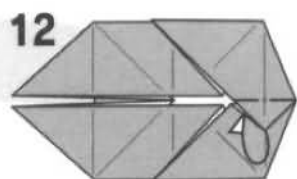

12
カドを内側に折る
Tuck the corner
inside.

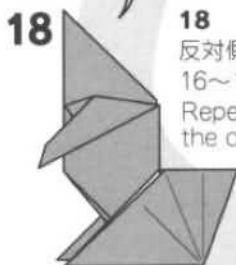

18
反対側も
16~17と同じ
Repeat 16~17 on
the other side.

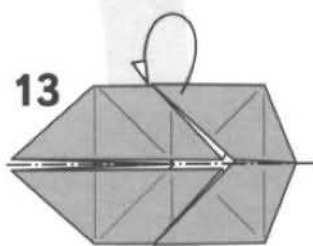

13
後ろへ半分に折る
Mountain fold in
half.



17
カドを
内側に折る
Inside reverse
fold.

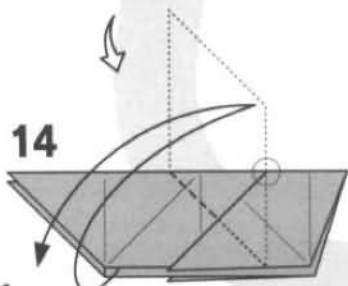

14
縁を○のところに
合わせて折り筋をつける
Precrease so that the bottom
edge touches the circled point.

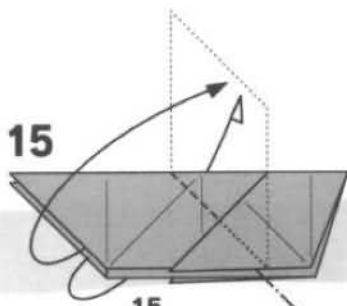

15
つけた折り筋で
かぶせ折り
Outside reverse fold.

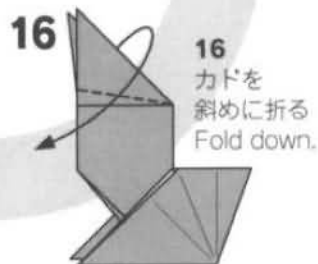

16
カドを
斜めに折る
Fold down.



27
カドを内側に折る
Inside reverse fold.

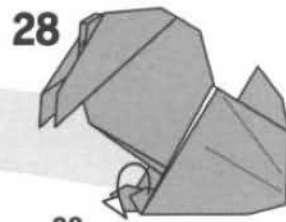

28
後ろ足の部分を
平らにして立たせる
反対側も同じ
Pull down the feet
so that it stands.

29
黒矢印の部分を押込んで
内側をひろげて立体的にする
Mold the arrowed part to
your taste so that it will
become three-dimensional.

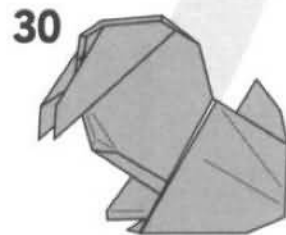
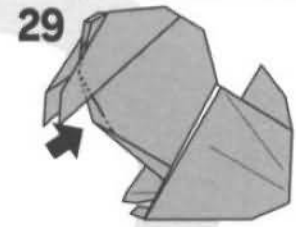

[体]のできあがり
[Body] Completed

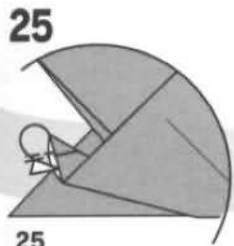

25
カドを内側に折る
Inside reverse fold.

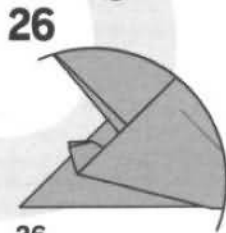

26
反対側も24~25と同じ
Repeat 24~25 on the
other foot.

[頭] Head

1
三角に折る
Fold corner to
corner.

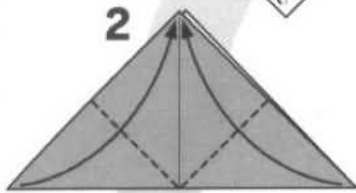
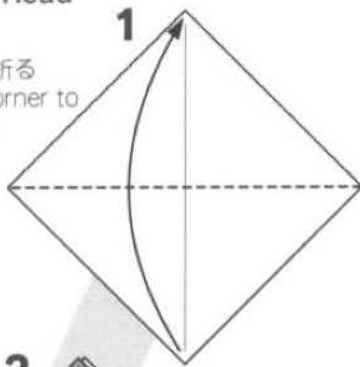

2
カドとカドを
合わせて折る
Fold side corners to
the top corner.

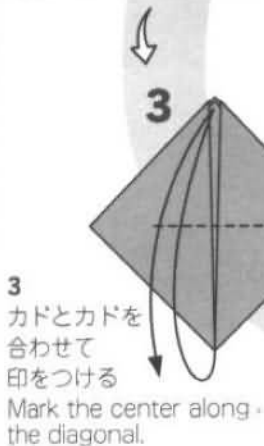

3
カドとカドを
合わせて
印をつける
Mark the center along
the diagonal.

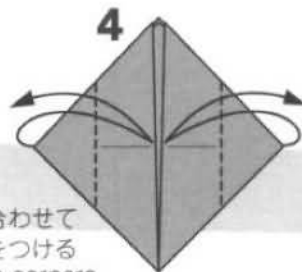

4
カドを
中心に合わせて
折り筋をつける
Fold the corners
to the mark.

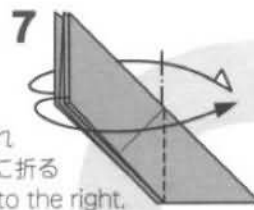

7
それぞれ
反対側に折る
Swivel to the right.

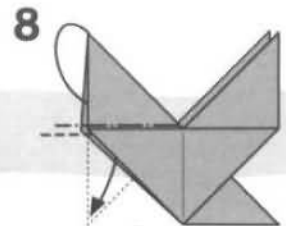

8
縁のところで
中わり折り
Inside reverse fold.

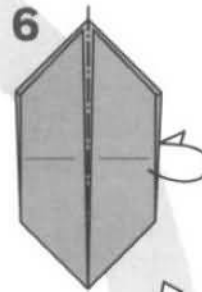

6
後ろへ半分折る
Mountain fold
in half.

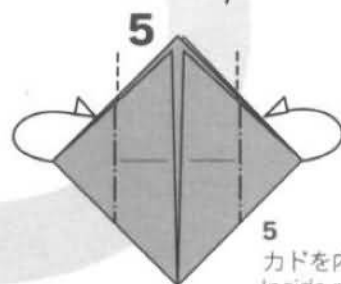

5
カドを内側に折る
Inside reverse
folds.

12 カドを斜めに折る
Valley fold down.

11 反対側も
9~10と同じ
Repeat 9~10
on the back.

10 開くところで
反対側に折る
Swivel to the left.

9 カドを折り筋に
合わせて折る
Fold the right middle
corner to the top of
the center line.

13 ■の部分
を2枚重ねて
内側に折る
Tuck the darkened part
(two layers)
inside.

14 反対側も12~13と同じ
Repeat 12~13 on
the back.

15 カドを斜めに折って
折り筋をつける
Preshape so that the
head tilts a little bit.

16 つけた折り筋で
かぶせ折り
Outside reverse fold.

17 縁を折り筋に
合わせて折る
Fold edge to
edge.

18 顔の部分をひろげて
立体的にする
Open the face part.
The result will become
three-dimensional.

19 カドを上
に折る
Fold the corner
up.

20 カドを少し折る
Fold the tip
down.

21 カドを
後ろへ折る
Mountain fold the
neck.

22 [頭]の
できあがり
[Head] Completed

23 できあがり
Model Completed

22 [頭]を[体]の
すき間に
差し込む
Insert the neck
into the body.

カンガルー

Kangaroo

ウサギ、カンガルー、パンダはそれぞれの下半身だけを見ると、それが何だかわからない不思議な形をしています。気の向くままに折っていると、何にも見えなくても、何とも魅力を感じる形に出会うことがあります。何だかわからない、でも何となく魅力的と感じる形を作品に定着させる方法として複合を捉え始めたのがこの頃です。

(Continued from notes on "Rabbit")

The three animals' lower parts are all of the shapes from which we cannot imagine what they are a part of. However, they are all of attractive shapes at the same time. A modular approach can provide you with a way to give such shapes their lives by combining them with something else.

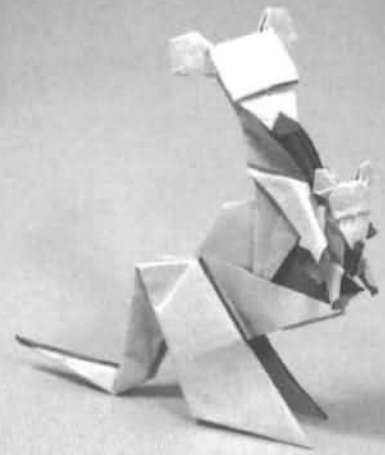

Created 1984 Paper 複合作品・3枚: 3 pieces

[紙の比率]
Paper Size

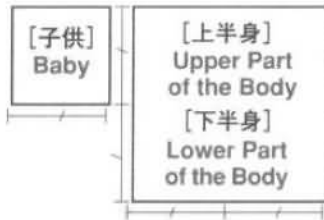

[上半身] Upper Part of the Body

P. 8 [正方基本形] からはじめる
Start with [Preliminary Base]. (P. 8)

1
カドとカドを
合わせて
折り筋をつける
Precrease along
the horizontal
diagonal.

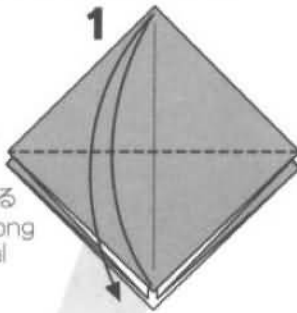

2
カドを中心に
合わせて
折り筋をつける
Precrease the
corners to the center.

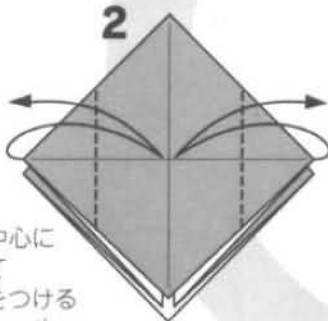

3
カドを中心に
合わせて
折り筋をつける
Precrease the top
corner to the center.

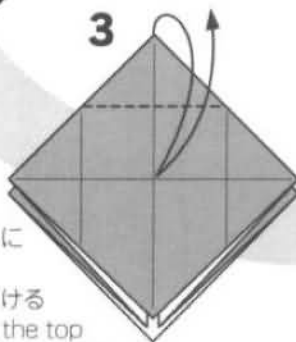

5
反対側も同じ
Repeat along
another center
line.

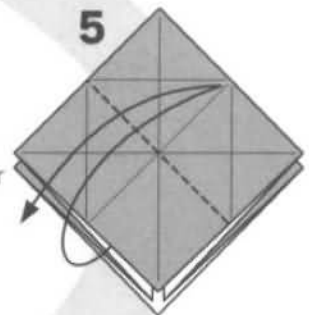

4
線と線に合わせて
斜めに折り筋を
つける
Precrease along
the center line.

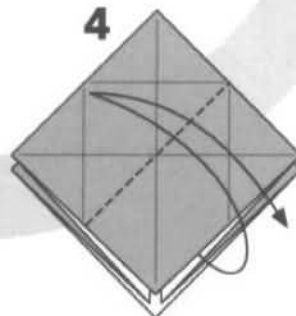

7
内側をひろげて
つぶすように折る
Open and
squash.

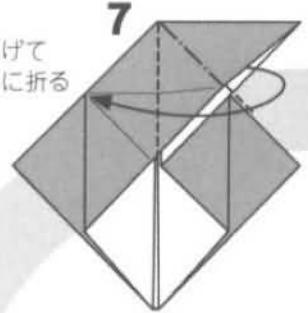

6
つけた折り筋を使って
内側をひろげて
つぶすように折る
Open, swivel, and squash
along the precreases.

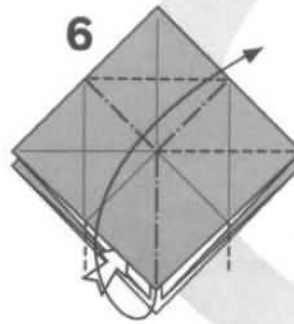

6
つけた折り筋を使って
内側をひろげて
つぶすように折る
Open, swivel, and squash
along the precreases.

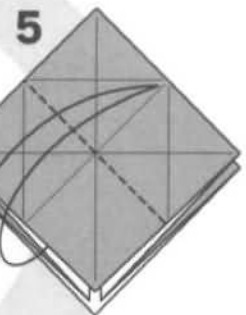

4
線と線に合わせて
斜めに折り筋を
つける
Precrease along
the center line.

11
上の1枚だけ
○と○を結ぶ線で
折り筋をつける
Precrease along the
line connecting the
circled points.

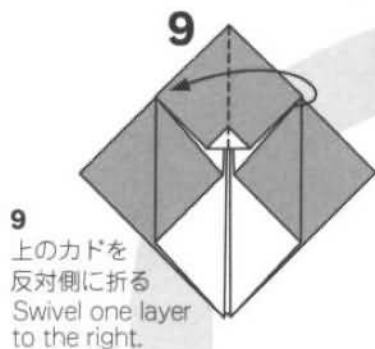

9
上のカドを
反対側に折る
Swivel one layer
to the right.

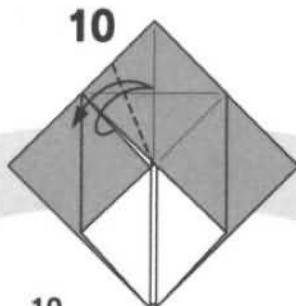

10
縁を中心に合わせて
折り筋をつける
Precrease the left
edge to the diagonal.

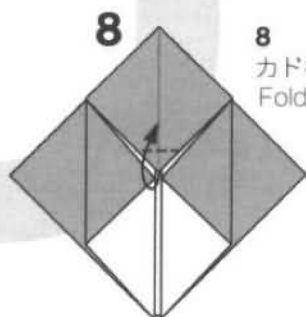
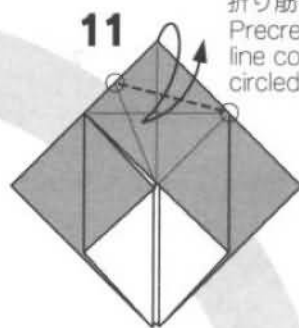

8
カドを少し上に折る
Fold up the tip.



12
11でつけた折り筋で
内側をひろげてつぶすように
折りながら黒矢印の部分
押し込むようにする
Open and swivel along
the precrease made in 11.
The top layer will be pulled up,
so push the arrowed part to
the left as far as it goes.

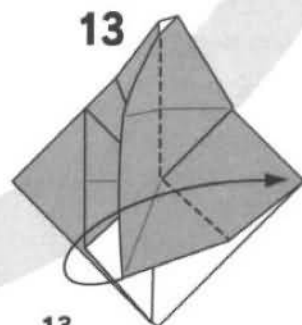

13
つられて上がった部分
つぶすように折る
Fold the pulled-up part
to the right, so the whole
thing will be flat.



14
縁を中心に合わせて折る
Fold the top edge to
the center diagonal.

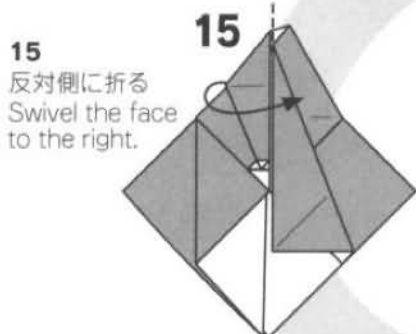

15
反対側に折る
Swivel the face
to the right.

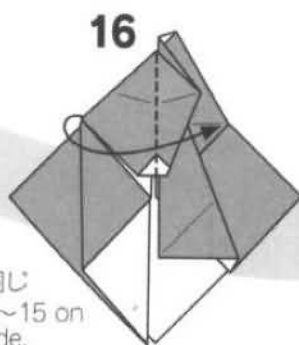

16
反対側も
9～15と同じ
Repeat 9～15 on
the left side.

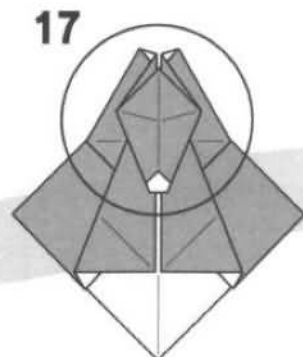

26
 縁を折り筋に合わせて
 折り筋をつける
 Precrease the side
 corners to the
 crease lines
 made in 25.

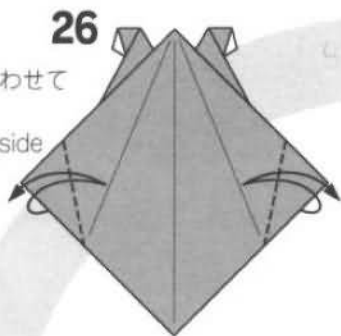

27
 縁を折り筋に合わせて
 折り筋をつける
 Precrease along angle
 bisectors.

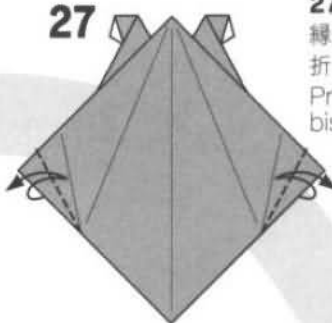

25
 縁を中心に合わせて
 折り筋をつける
 Precrease the edges to
 the center diagonal.

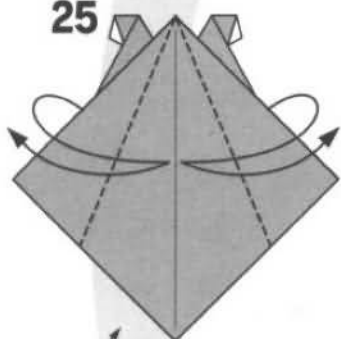

28
 カドを内側に折る
 Inside reverse folds.

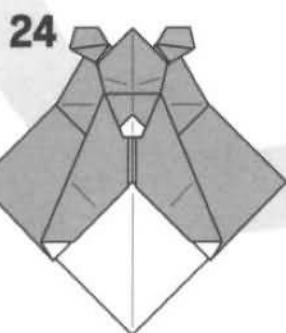
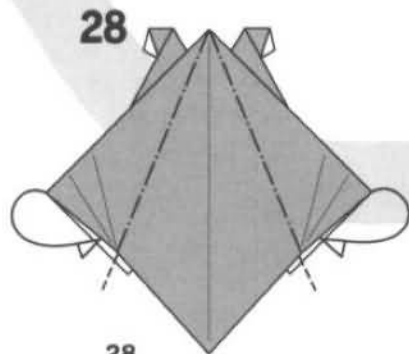

23
 カドを下の線のところで
 内側に折る
 Mountain folds
 along the edges.

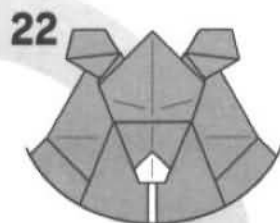
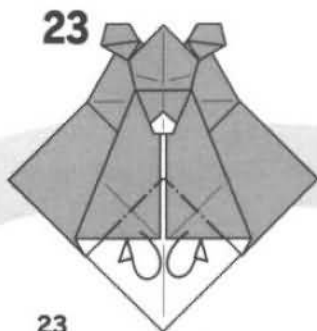

18
 下の折り筋のところで
 折り筋をつける
 Precrease along the
 crease line on the
 lower layer.

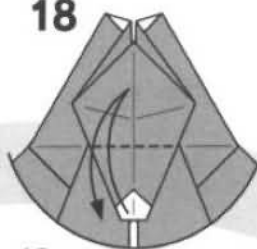

19 内側に段折り
 Pleat inside.

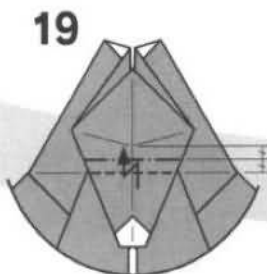

20
 中わり折り
 Inside reverse folds.

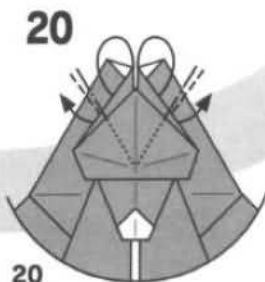

21
 縁のところで
 内側に折る
 Mountain folds
 along the edges.

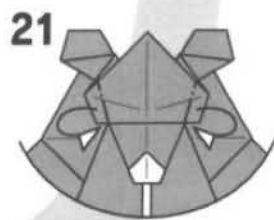

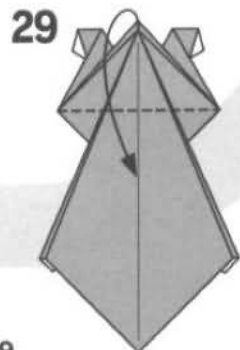

29
カドをひらくところを下に折る
Swivel the top layer as far as it goes.

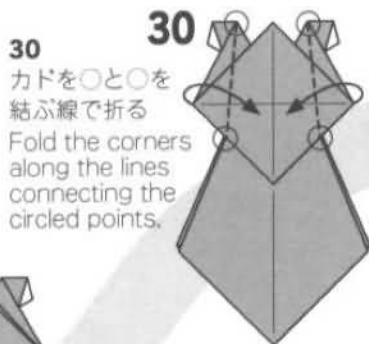

30
カドを○と○を結ぶ線で折る
Fold the corners along the lines connecting the circled points.



31
カドを下に折る
Fold down the top of the head.



32

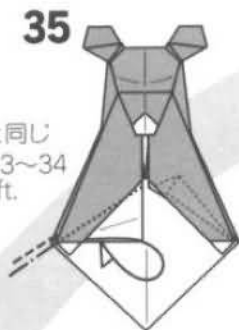

35
反対側も
33～34と同じ
Repeat 33～34 on the left.

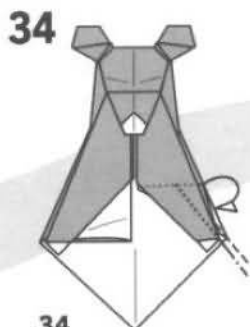

34
ついている折り筋で
縁と縁を合わせて
カドを内側に折る
Inside reverse fold along the precreases.

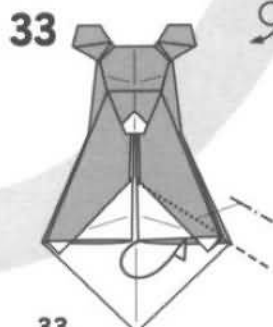

33
ついている折り筋で
縁と縁を合わせて
カドを内側に折る
Inside reverse fold along the precreases.

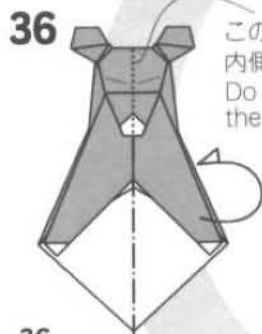

36
この部分は内側だけ折る
Do not fold the head.

36
後ろへ半分に折る
Mountain fold in half.



37
後ろへ軽く折って
立体的にする
Pinch the face a little, so that it becomes three-dimensional.

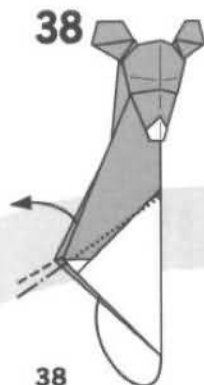

38
内側の縁に合わせて
中わり折り
Inside reverse fold along the inner edges.



39
開くところで
カドを斜めに折る
Swivel up.

[下半身]
Lower Part of
the Body

1
線を中心に
合わせて折る
Fold the side
corner to the
diagonal.

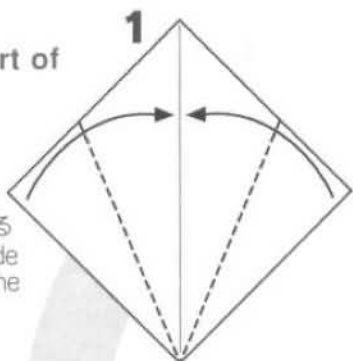

2
線のところ
で折る
Fold down
along the edge.

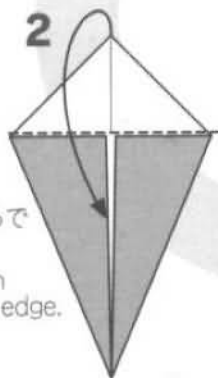

3
線を中心に
合わせて
折り筋をつける
Fold the corners
to the center line.

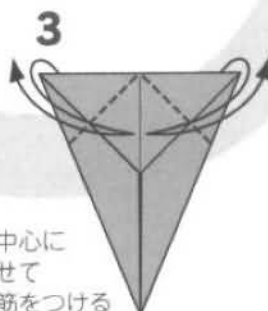

4
戻す
Unfold.

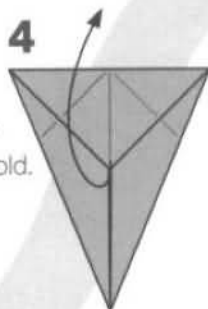

5
3でつけた
折り筋を使って
カドとカドを
合わせて折る
Fold along the
crease line
made in 3.

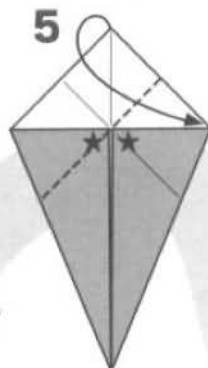

6
内側をひろげて
つぶすように折る
Open and squash.

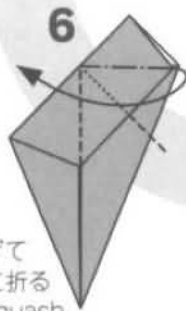

46



[上半身]の
できあがり
[Upper Part]
Completed

45

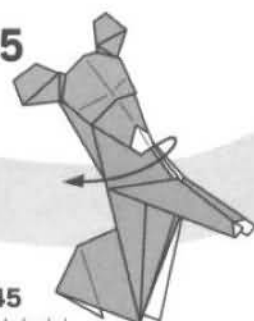

45
首を少し
カーブさせる
Bend the neck.

44



44
つけた折り筋と
線の交点のところで
中わり折り
Inside reverse fold at
the end of the crease
line made in 43.

43



43
カドを線に合わせて
折り筋をつける
Precrease so that the
corner at the bottom
touches the middle
edge below the arm.

41

線と線に合わせて
後ろへ折る
Mountain fold
edge to edge.

41



42

42
反対側も39~41と
同じ
Repeat 39~41 on
the other arm.



40

線を折り筋に
合わせて折る
Fold down along
the crease line.



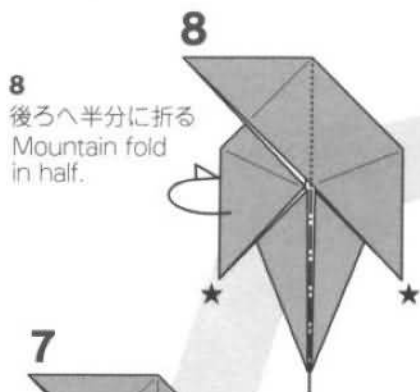

8
後ろへ半分に折る
Mountain fold
in half.



9
縁を折り筋に
合わせて
斜めに折る
Fold along the
angle bisectors.

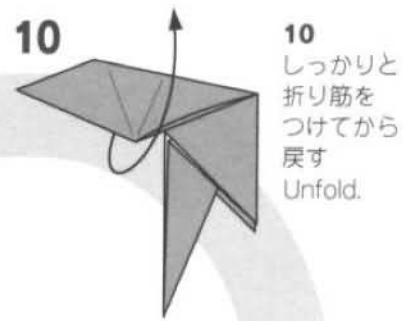

10
しっかりと
折り筋を
つけてから
戻す
Unfold.

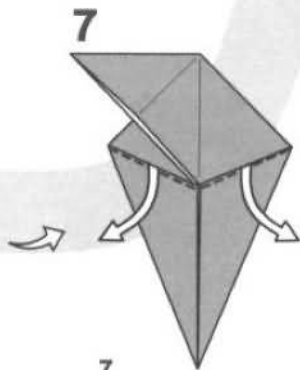

7
内側の5のカド(★)を
引き出してつまむ
ように折る
Pull out the corners.

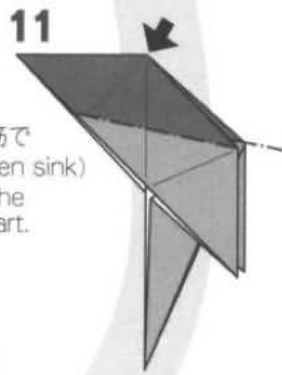

11
つけた折り筋で
沈め折り(open sink)
Open sink the
darkened part.

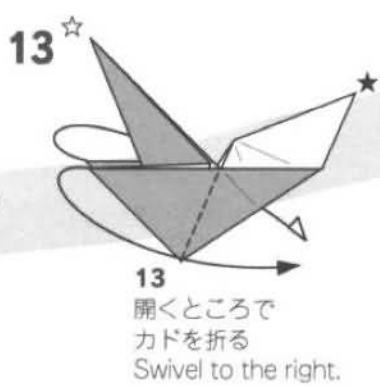

13
開くところで
カドを折る
Swivel to the right.

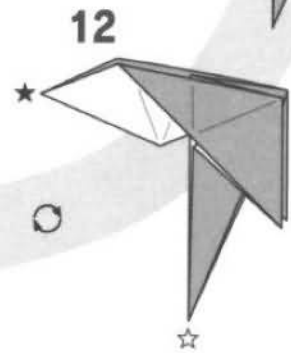

12



14
縁と縁を合わせて
カドを内側に折る
Mountain fold
edge to edge.

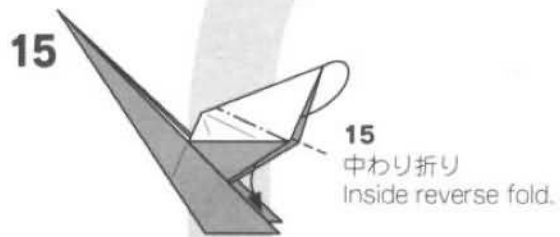

15
中わり折り
Inside reverse fold.

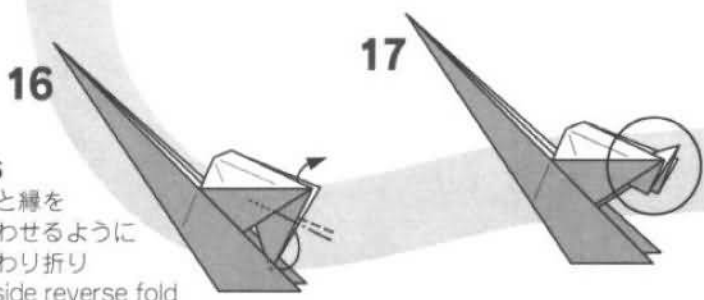

16
縁と縁を
合わせるように
中わり折り
Inside reverse fold
so that the four edges
created align with each other.

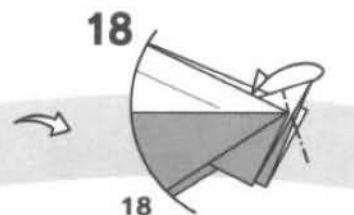

18
かぶせ折り
Outside reverse fold.

[組み立て方]
Assembly

1
上半身のカドを
下半身の部分の
すき間に差し込む
Insert the bottom
corners of the upper
part into the pockets
on the top of the
lower part.



2
途中の図
カドをすき間に
差し込む
Inserting...



3
袋の部分
を立体にする
Make the pouch
three-dimensional.

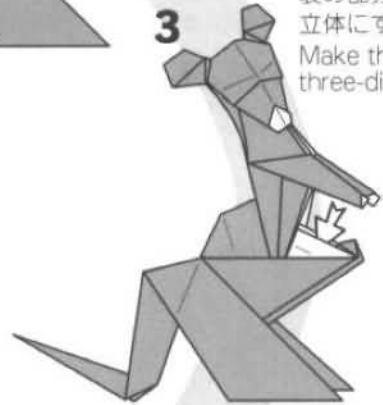

23
[下半身]の
できあがり
[Lower Part]
Completed

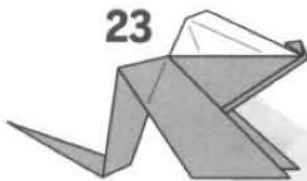

22
22
中わり折り
Inside reverse fold.

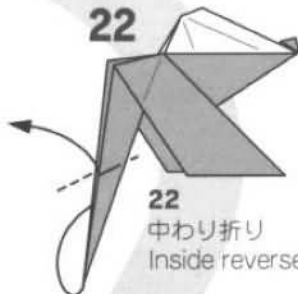

21
21
中わり折り
Inside reverse
fold.

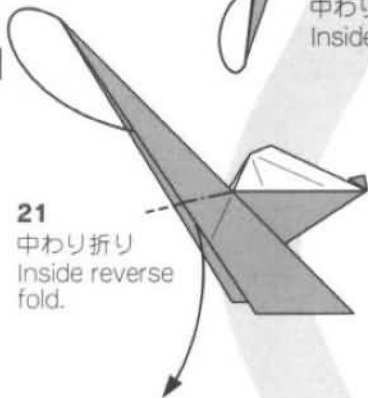

20

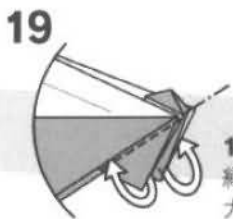

19
縁のところで
カドをすき間に
折り込む
Tuck the corners
into the slots.

4
4
1/4の紙でもう一つ
上半身を作り
袋の部分に差し込む
Make the upper part
of a young with a
sheet of the quarter
size and insert it into
the pouch.

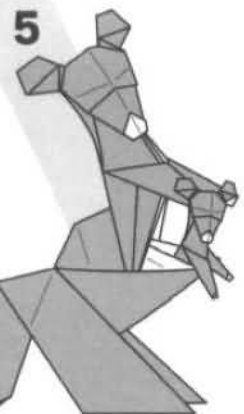
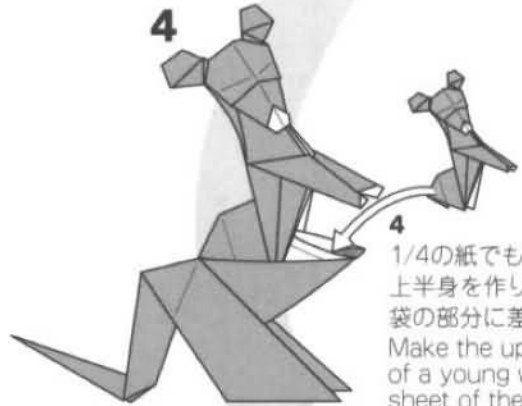

できあがり
Model Completed

パンダ

Panda

正方形を2回“きっちり折り”して出来る形を幾つか考えてみましょう。図3のシルエットを真っ先に考える人は希です。この折り出しを作品に定着させたいとの思いが、パンダの下半身に結びついています。TVチャンピオンで、このパンダの顔を「話しかけているみたい」と評してくれた女の子の言葉が忘れられません。

Can you imagine the shape of 3 can be obtained by only two folds from a square? When I created Panda, I wanted to give this wondrous shape a life in origami. I still remember a girl commenting on this Panda that it looks like talking to her, when I displayed it for a TV program.

Created 1982 Paper 複合作品・2枚: 2 pieces

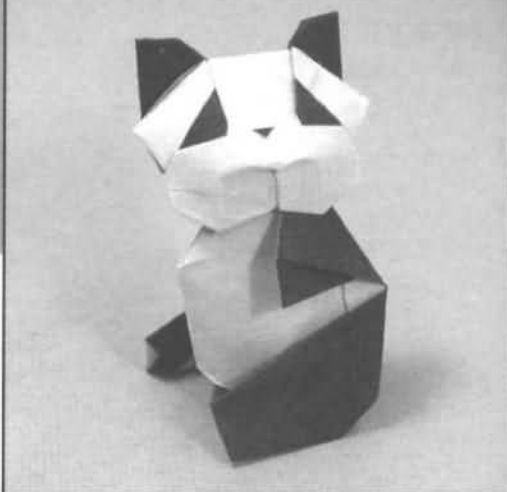

[体] Body

[頭]が15×15cmの場合、
[体]は18×18cmの紙で
折ると良い

When using a 15cm ×
15cm sheet for the head,
the body should be
folded with 18cm ×
18cm.

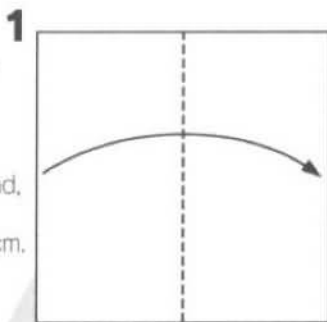

1
半分に折る
Fold in half.

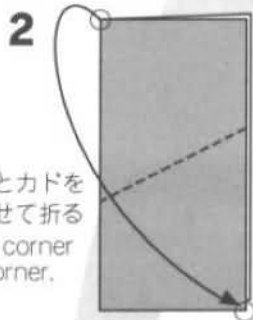

2
カドとカドを
合わせて折る
Fold corner
to corner.

[紙の比率]
Paper Size

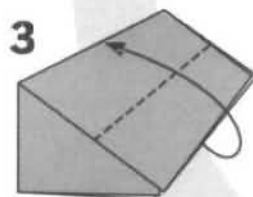
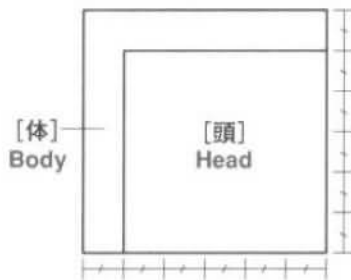

3
縁と縁を合わせて折る
Fold edge to edge.

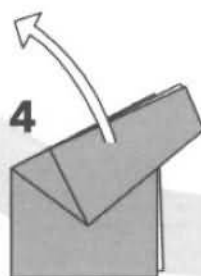

4
しっかりと
折り筋を
つけてから
2の形まで戻す
Unfold to 2.

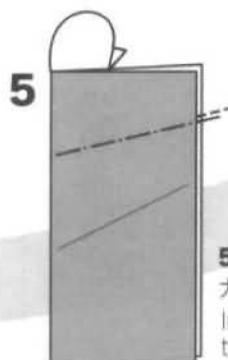

5
カドを内側に折る
Inside reverse fold
along the crease line.

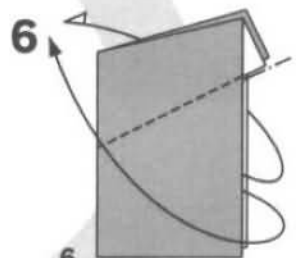

6
かぶせ折り
Outside reverse fold
along the crease line.

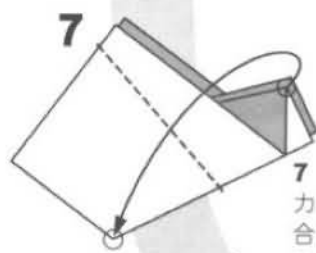

7
カドとカドを
合わせて折る
Fold corner
to corner.

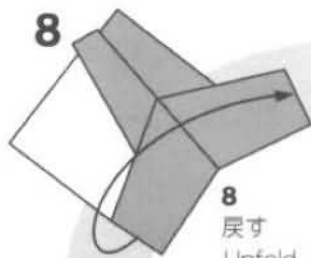

8
戻す
Unfold.

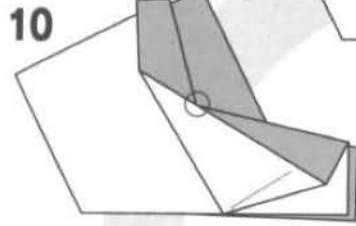

10

10
反対側も同じ
Repeat on the back.

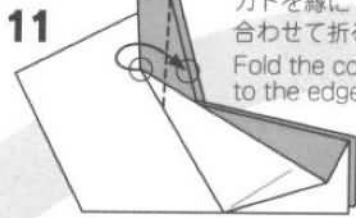

11

11
カドを縁に
合わせて折る
Fold the corner
to the edge.

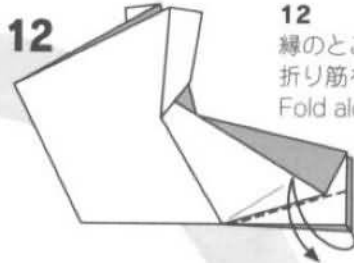

12

12
縁のところで
折り筋をつける
Fold along the edge.

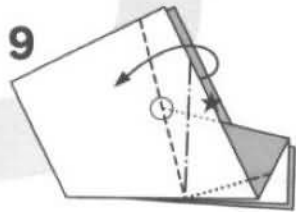

9

9
★の縁を○の交点に
合わせるように
引き寄せ折り
Swivel along the line
touching the circled
intersection and squash.

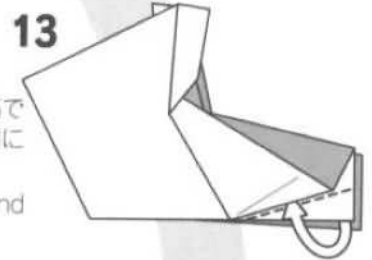

13

13
つけた折り筋で
カドをすき間に
折り込む
Valley fold and
tuck inside.

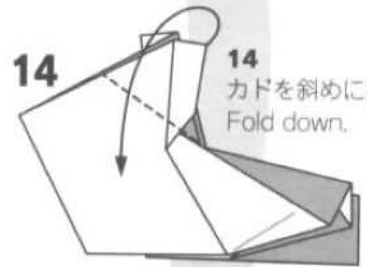

14

14
カドを斜めに折る
Fold down.

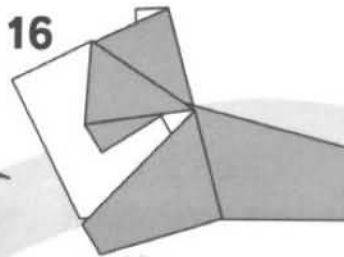

16

16
反対側も11~15と同じ
Repeat 11~15 on
the back.

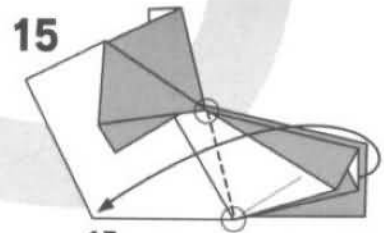

15

15
カドとカドを結ぶ線で折る
Swivel along the line
connecting
the circled corners.

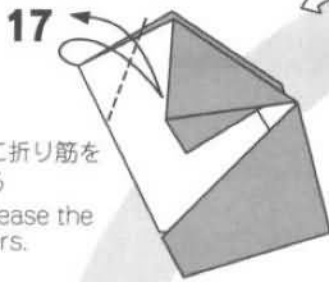

17

17
斜めに折り筋を
つける
Precrease the
corners.

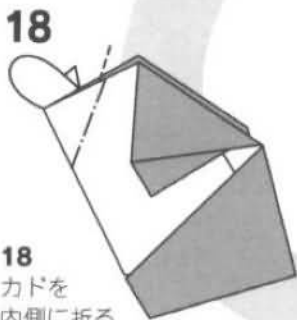

18

18
カドを
内側に折る
Inside reverse fold.



19

19
軽くひろげて
内側を見る
Open lightly.
The inside view.



20

20
カドを折って中が
開かないように止める
Lock the opening by
folding the inner corner.
Close the opening.

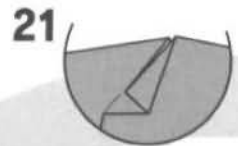

21

26
矢印の部分を
押し込んで
内側をひろげて
立体的にする
Push the belly and
make the body
three-dimensional.

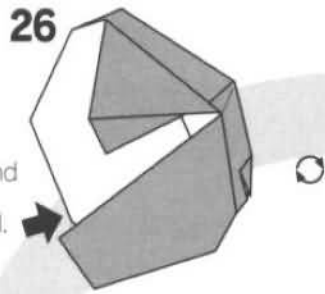

[体]のできあがり
[Body] Completed

25

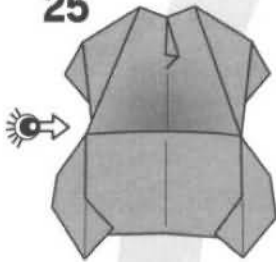

24

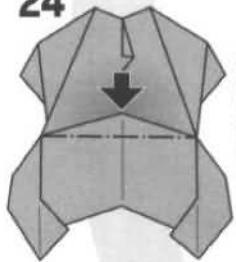

24
黒矢印の部分を
押し込んでひろげる
Push and flatten
the arrowed corner.

23

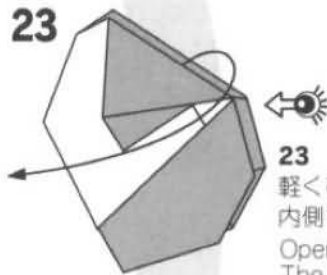

23
軽くひろげて
内側を見る
Open lightly.
The inside view.

22

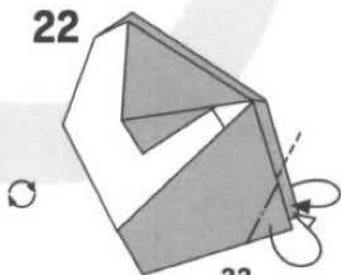

22
カドを内側に折る
Tuck the corners
inside.

[頭] Head

1
カドを中心に
合わせて折る
Fold the bottom
edges to the
diagonal.

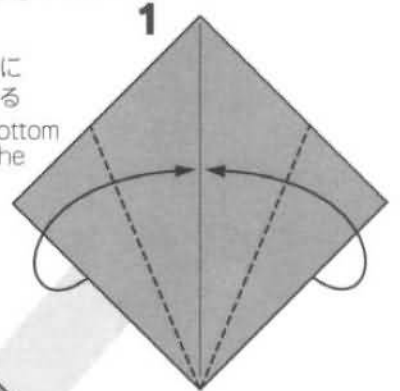

2

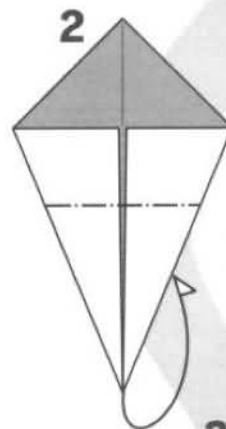

2
カドとカドを
合わせて
後ろへ折る
Mountain fold corner
to corner.

3

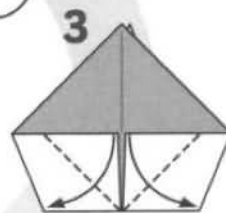

3
縁と縁を合わせて折る
Fold and align
the center edge with
the bottom edge.

4

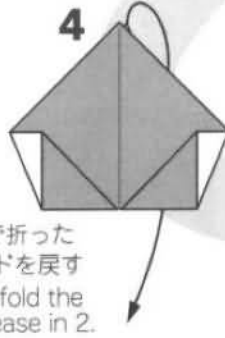

4
2で折った
カドを戻す
Unfold the
crease in 2.

5

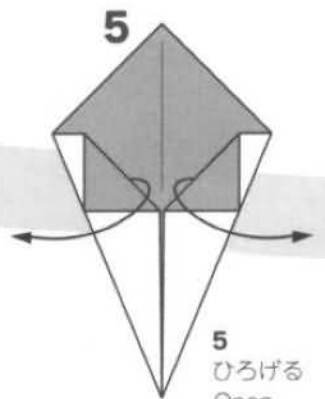

5
ひろげる
Open.

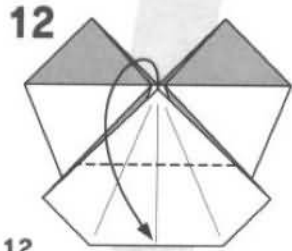
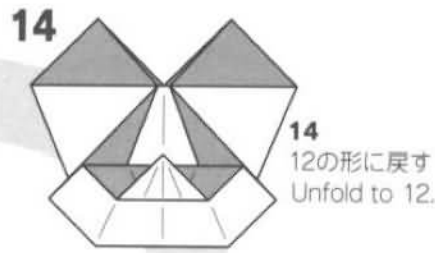
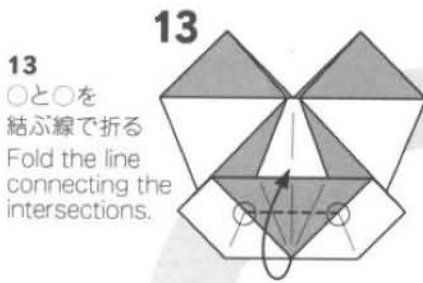

12
カドを線に合わせて折る
Fold down the corner
to the bottom edge.

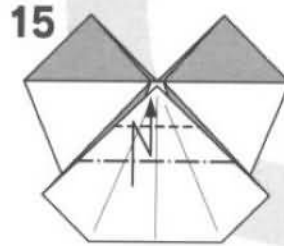

15
内側に段折り
Pleat inside.

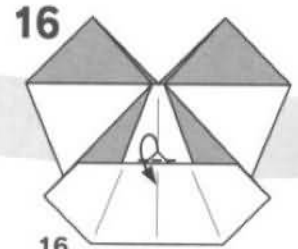

16
カドを線のところで
下に折る
Valley fold the tip down.

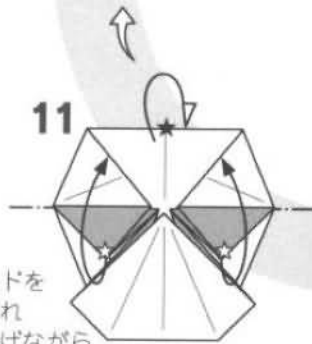

11
☆のカドを
それぞれ
折り上げながら
★の部分の後ろへ折る
Swivel the top part along
with the colored triangles.

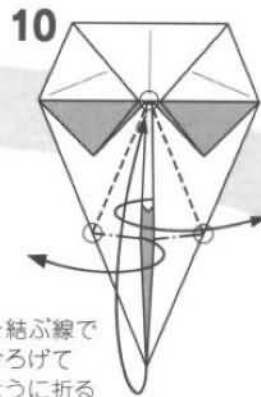

10
○と○を結ぶ線で
内側をひろげて
つぶすように折る
Open at the ends of
the precrease in 9
and squash.

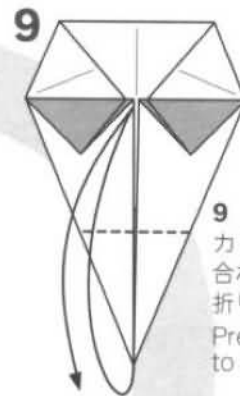

9
カドとカドを
合わせて
折り筋をつける
Precrease corner to
corner.

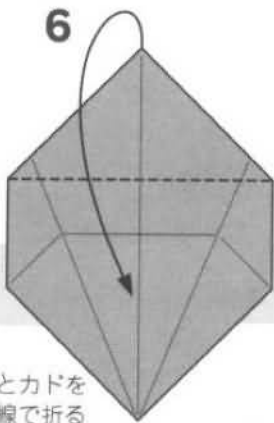

6
カドとカドを
結ぶ線で折る
Fold along the line
connecting the side corners.

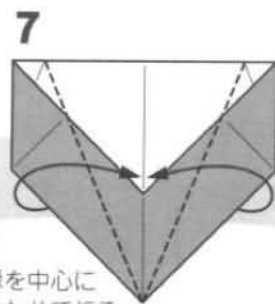

7
線を中心に
合わせて折る
Fold the edges to
the center.

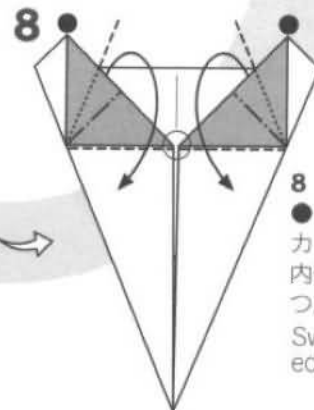

8
●のカドを○の
カドに合わせて
内側をひろげて
つぶすように折る
Swivel along the
edges and squash.

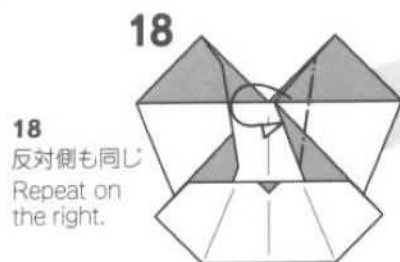

18
反対側も同じ
Repeat on
the right.

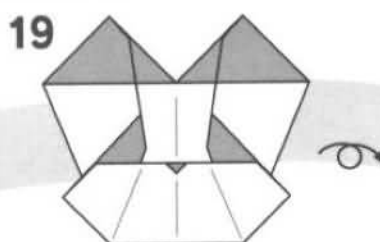

19

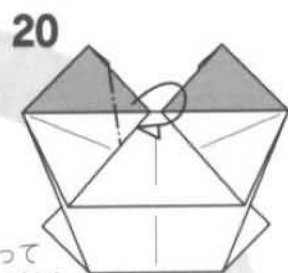

20
下の縁に沿って
カドを後ろへ折る
Repeat tucking
inside along the
edge.

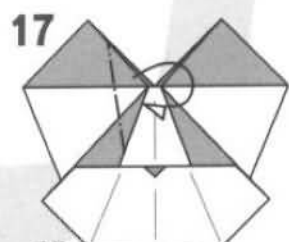

17
カドを後ろに折る
Tuck the corner
inside.



21
反対側も同じ
Repeat on
the right.

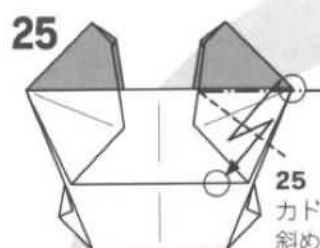

25
カドを縁に合わせて
斜めに段折り
Pleat down so that
the side corner touches
the middle edge.



24
反対側も同じ
Repeat on
the left.

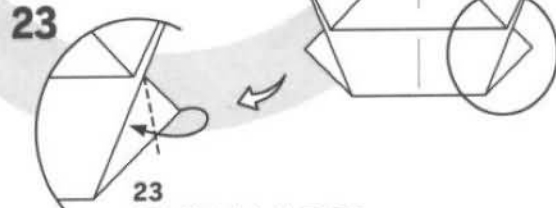

23
縁と縁を合わせて折る
Fold edge to edge.

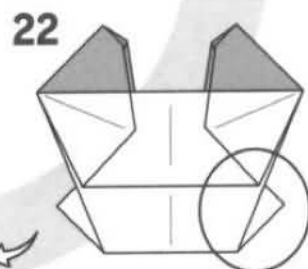

22

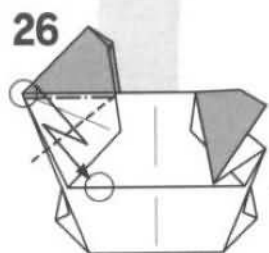

26
反対側も同じ
Repeat on the left.

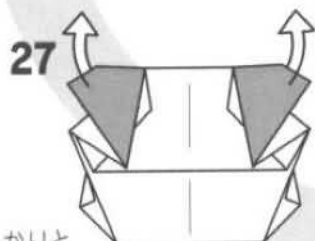

27
しっかりと
折り筋をつけてから
25の形に戻す
Unfold to 25.

28
内側に斜めに段折り
Pleat inside along the
crease lines made in 25.

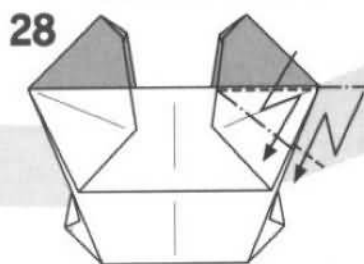

28

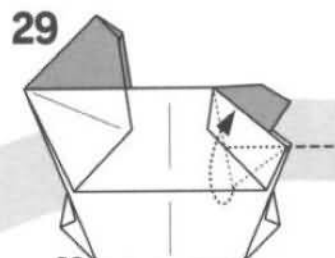

29
内側のカドを折って留める
Lock the ear by folding up
the hidden corner.

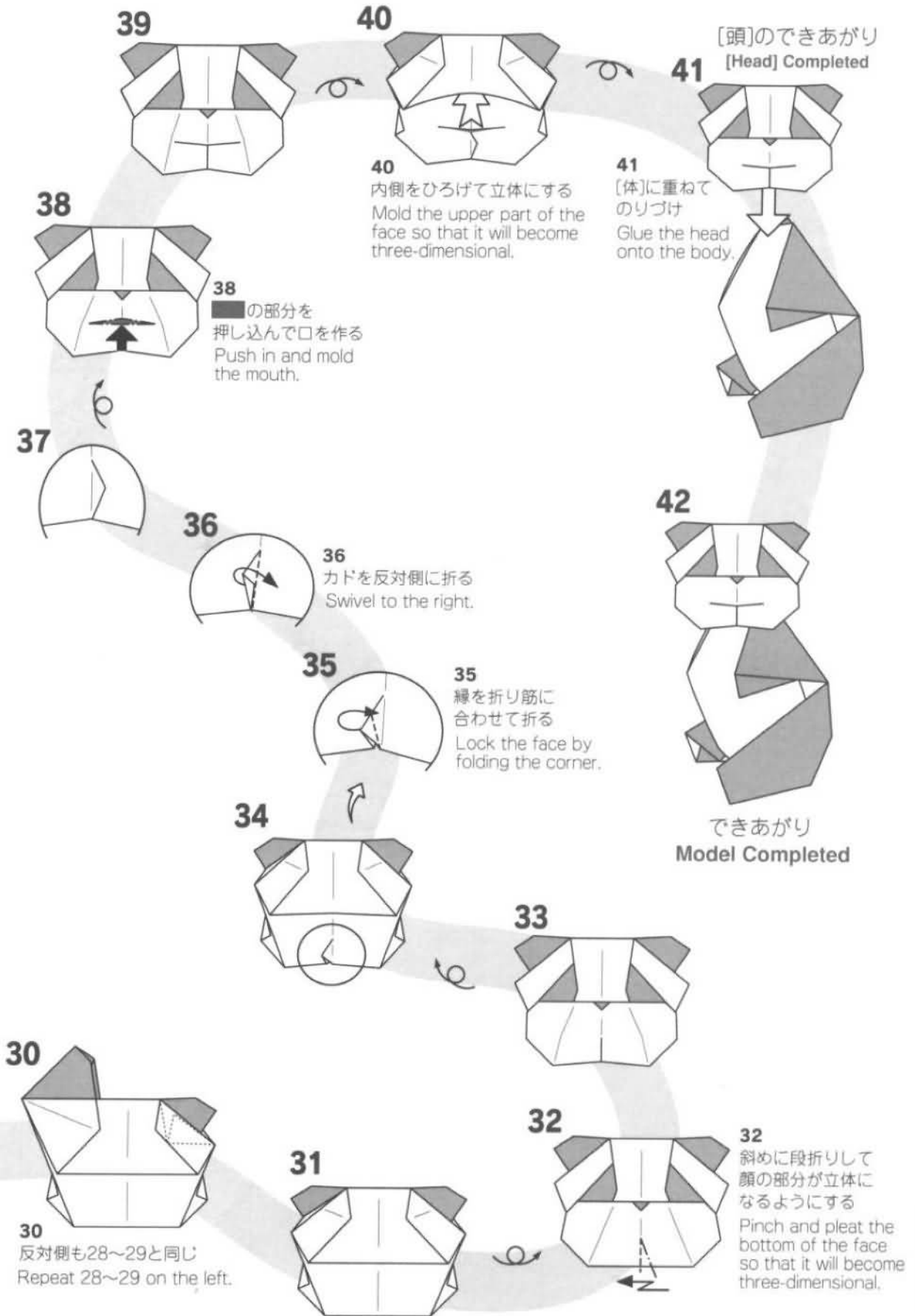

キリン

Giraffe

ジョン・モントロールさんの“Dog base”に触発されて動物の基本形と呼べるようなものを目指し、折りだし感覚の類似した2系統(キリンとライオン・犬類)を考えてみました。キリンを作るのにこの基本形を用いたのは、たてがみの表現が自然に行えるためです。

When I created this Giraffe, the Lion and the dogs, I had in my mind ideas about a new “animal base”. For a Giraffe, this “base” is useful for an expression of a mane.

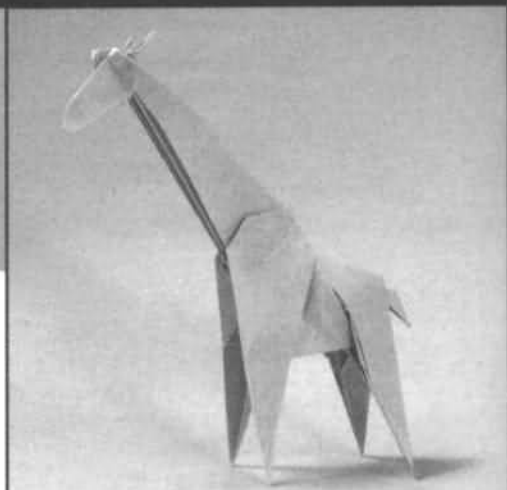

Created 1990 Paper 不切正方一枚折り: 1 piece

1
三角に折る
Fold along the
diagonal with the
colored side
inside.

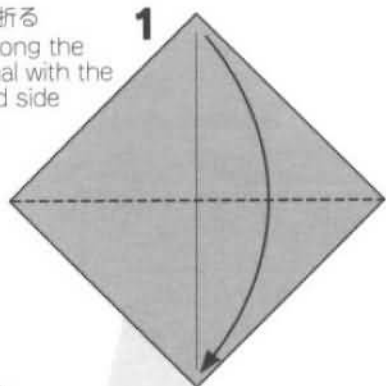

2
カドと
カドを
合わせて
折り筋をつける
Pre-crease the side
corners to the bottom corner.

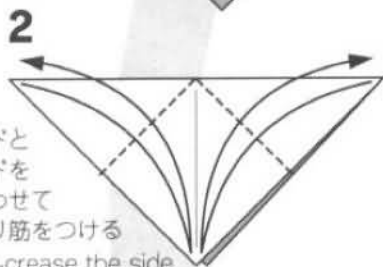

3
カドを内側に折る
Inside reverse fold.

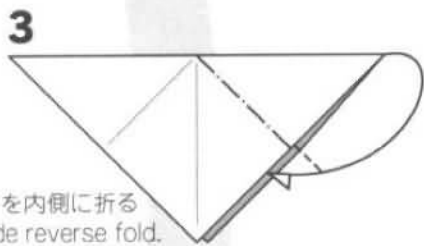

4
カドとカドを
合わせて
折り筋をつける
Fold corner to corner.

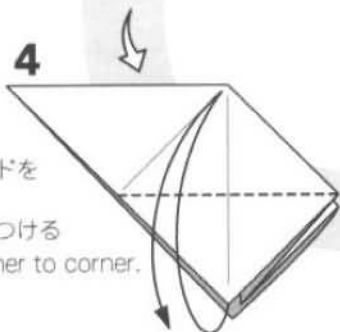

5
線と線
合わせて
印をつける
Mark the middle
point of the right
bottom edge.



7
○と○を
結ぶ線で
印をつける
Put a mark at the
intersection of the
line connecting the
two marks made in 5 and 6 and the vertical diagonal.

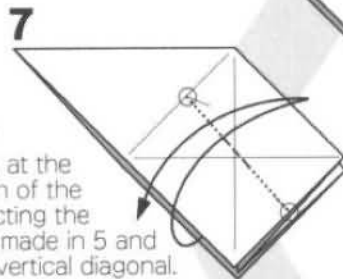

8
カドを
折り筋の交点
に合わせて折る
Fold the top corner
to the mark made in 7.

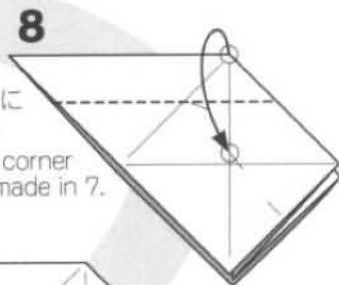

9
内側をひろげて
つぶすように折る
Open and squash.

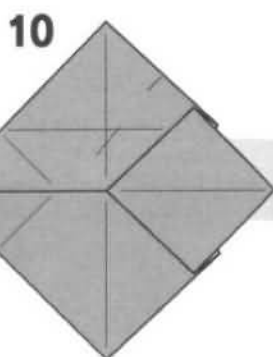
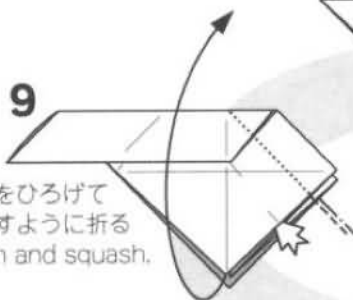

12

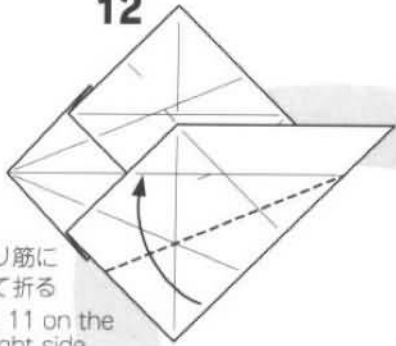

12
 縁を折り筋に
 合わせて折る
 Repeat 11 on the
 lower right side.

13

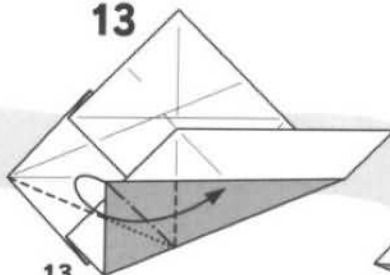

13
 カドをつまんで
 反対側に折る
 Swivel and squash.

14

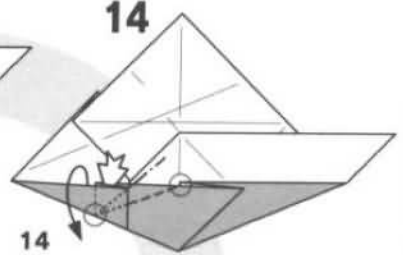

14
 内側をひろげてつぶすように折る
 Fold one layer along the line
 connecting the circled points
 and flatten the layers pulled up.

11

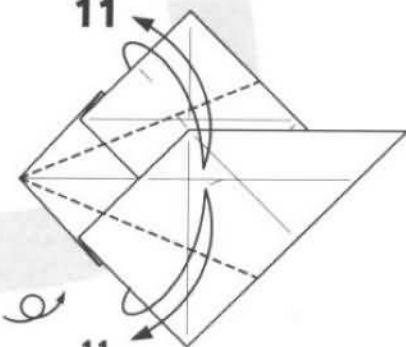

11
 縁を折り筋に合わせ
 て折り筋をつける
 Precrease along the
 angle bisectors.

15

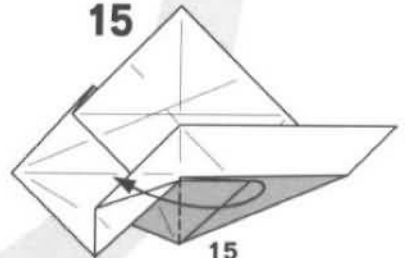

15
 カドを反対側に折る
 Swivel to the left.

16

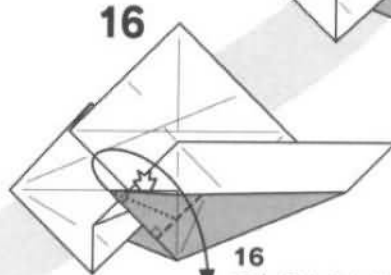

16
 縁と縁を合わせて内側を
 ひろげてつぶすように折る
 Fold along the angle bisector,
 while swiveling down the
 triangle.

17

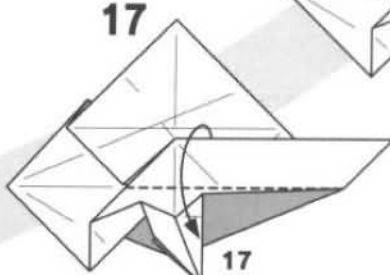

17
 縁を下に折る
 Fold down.

18

18
 反対側も
 12~17と同じ
 Repeat
 12~17 on
 the upper
 side.

18

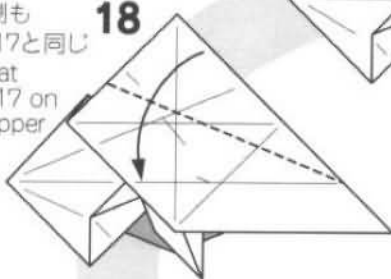

19

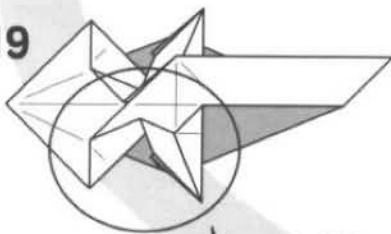

20
 縁と縁を合わせて
 引き寄せ折り
 Swivel to the right,
 while pulling down
 the layers above.

20

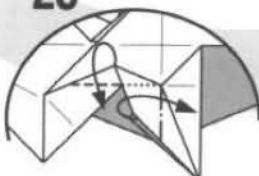

21

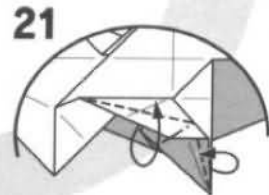

21
 カドを縁に合わせ
 て引き寄せ折り
 Fold one layer along
 the angle bisector.
 Note the pulled-up
 layer again.

22

22
 反対側も20~21と同じ
 Repeat 20~21 on
 the upper part.

22

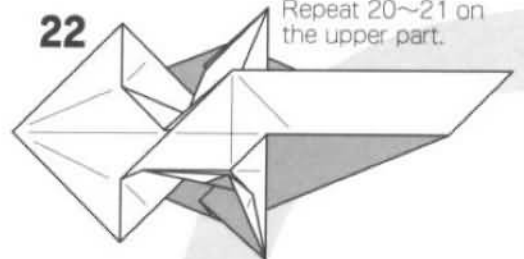

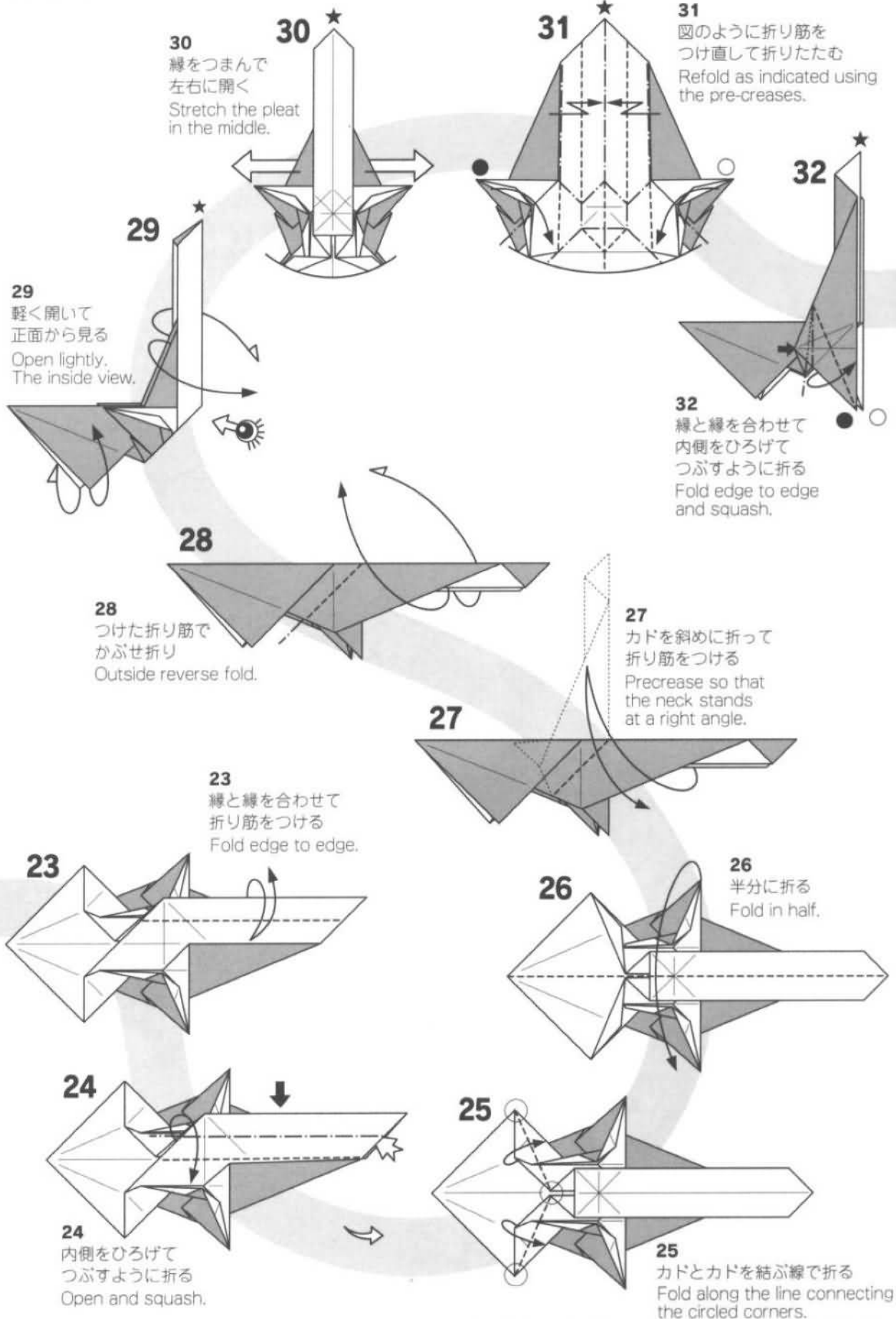



33
カドを反対側に折る
Swivel to the left.



34
■の部分を沈め折り
(closed sink)
反対側も32~34と同じ
Closed sink the
darkened part.
Repeat on the back.

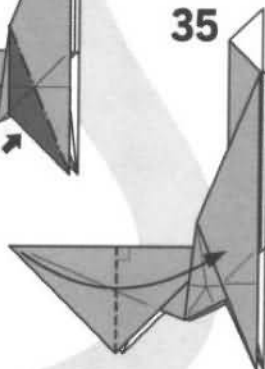

35
縁と縁を合わせて
カドを反対側に折る
Valley fold at a
right angle.

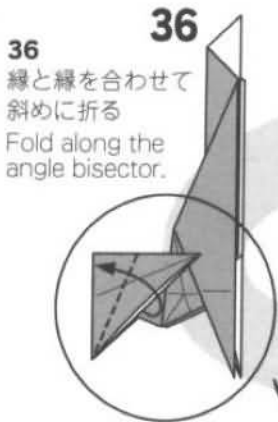

36
縁と縁を合わせて
斜めに折る
Fold along the
angle bisector.

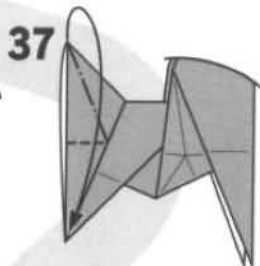

37
カドをつまむ
ように折る
Swivel down
and squash.

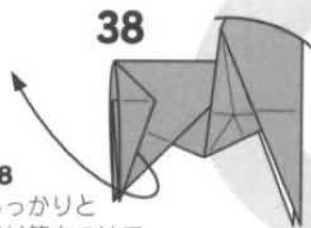

38
しっかりと
折り筋をつけて
35の形まで戻す
Unfold to 35.

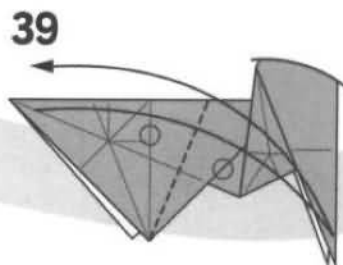

39
○と○を合わせて
折り筋をつける
Precrease aligning
the center line and
the right edge.

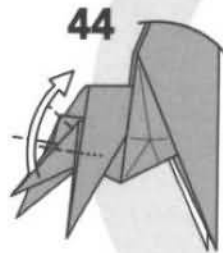

44
途中の図
... while pulling
the tail up.

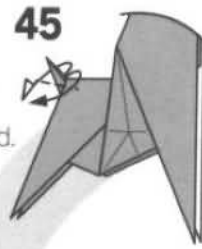

45
かぶせ折り
Outside
reverse fold.

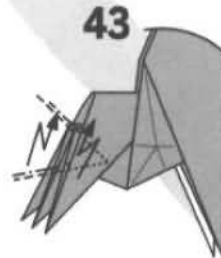

43
内側のカドを
斜めに段折り
Pleat the middle
layers inside ...

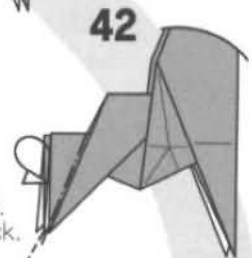

42
カドを内側に折る
反対側も同じ
Inside reverse fold.
Repeat on the back.

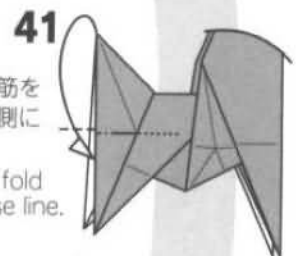

41
ついている折り筋を
使ってカドを内側に
折る
Inside Reverse fold
along the crease line.

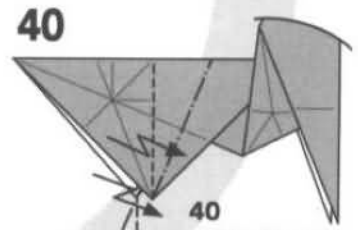

40
内側に斜めに
段折り
Pleat inside.

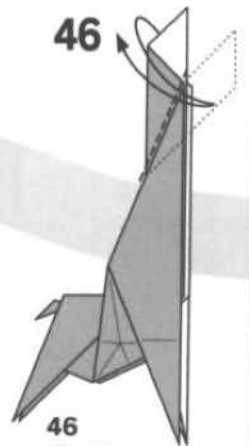

46
縁に沿って
折り筋をつける
Fold along the
edge.

47
軽く開いて
正面から見る
Open lightly.
The inside view.

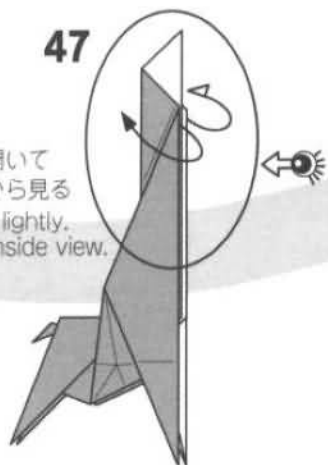

48
図のように
折り筋を
つけ直して
折りまとめる
Reassemble as
indicated using
the pre-creases.

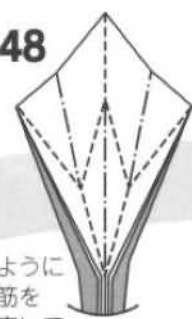

49
しっかりと折り筋をつけて
もう一度ひろげる
Fold tightly, and open
again.

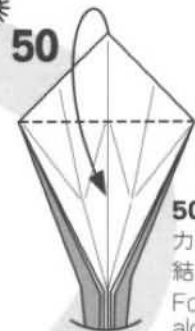

50
カドとカドを
結ぶ線で折る
Fold down
along the line
connecting
the corners.

53
内側のカドを
引き出す
Pull out the
middle layer.

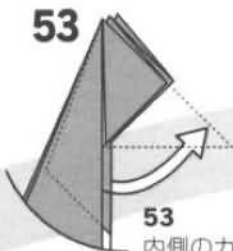

51
ついている折り筋で
折りまとめる
Assemble as indicated
using the pre-creases.

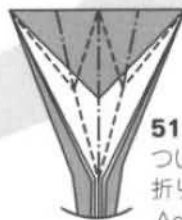

54
線と線に合わせて
折り筋をつける
Fold edge to edge.



55
カドを内側に折る
Inside reverse fold.

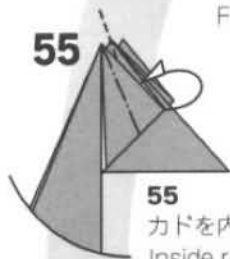

60
折り筋をつける
Make a
crease line.

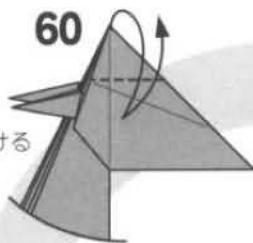

61
沈めるように
斜めに段折り
Pleat inside.



56
カドを反対側に折る
Swivel to the left.



59
折り筋をつける
Make a crease line.

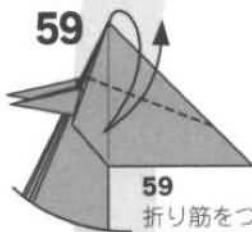

62
折り筋をつける
Pre-crease
edge to edge.



57
中わり折り
Inside
reverse fold.

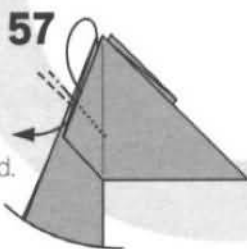

58
反対側も54~57と同じ
Repeat 54~57 on the back.

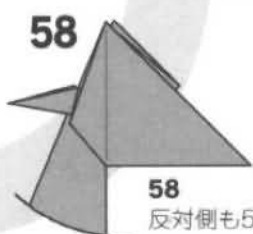

63
カドを押し込む
ように内側に折る
Inside reverse
fold.



73
カドを内側に折る
Tuck inside.

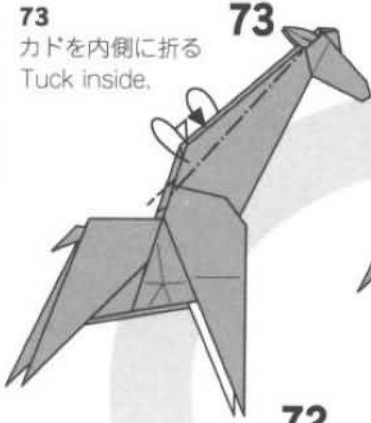

72
カドを内側に折る
Tuck inside.



71
カドを内側に折る
Mountain fold the tip.

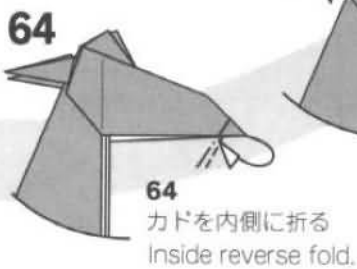

64
カドを内側に折る
Inside reverse fold.



65
耳をひろげて
形を整える
反対側も同じ
Shape the ears.

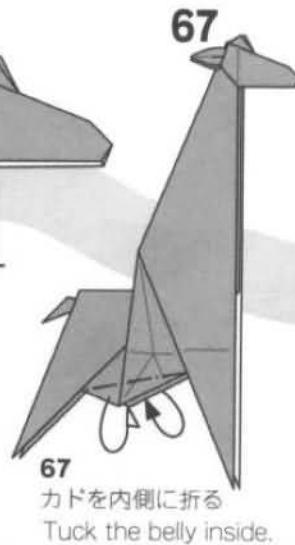
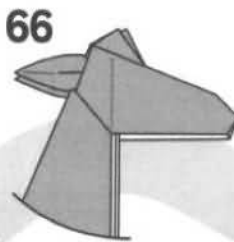

67
カドを内側に折る
Tuck the belly inside.

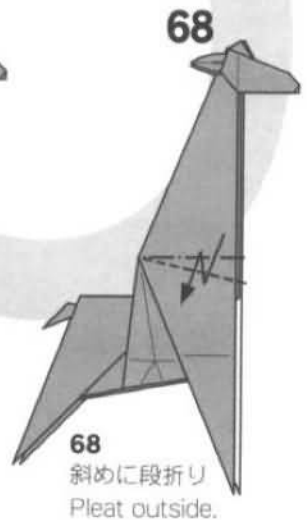

68
斜めに段折り
Pleat outside.

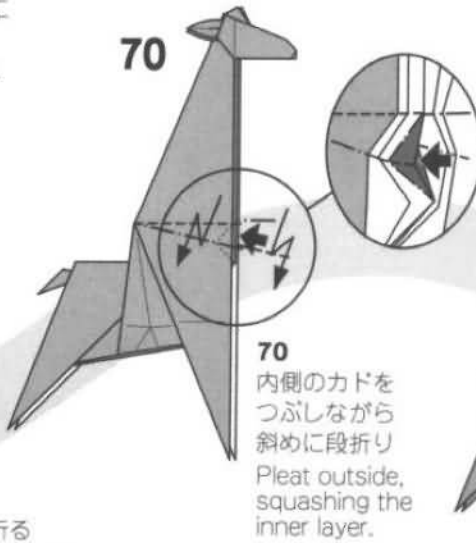

70
内側のカドを
つぶしながら
斜めに段折り
Pleat outside,
squashing the
inner layer.

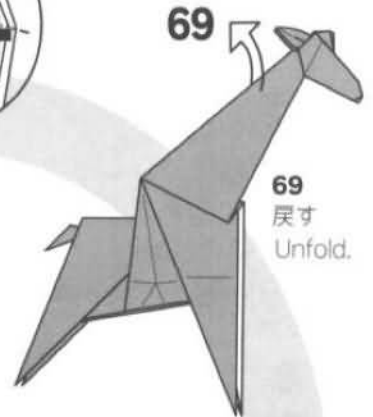

69
戻す
Unfold.

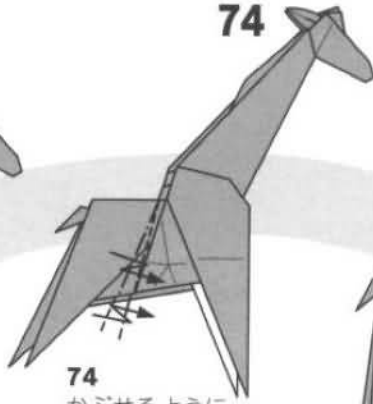

74
かぶせるように
斜めに段折り
Pleat outside.

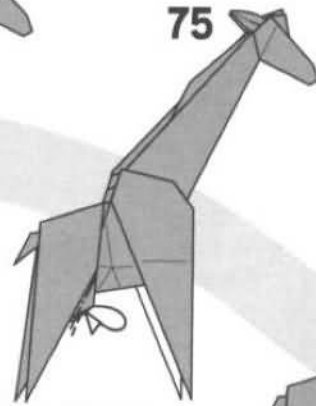

75
カドを内側に折る
反対側も同じ
Tuck inside.
Repeat on the back.

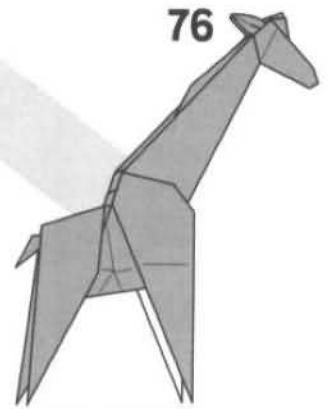

できあがり
Model Completed

ライオン

Lion

キリンの折りだし感覚(裏から折り始めて、真ん中を折って広げる)を保ちますが、最初の角度を変えます。この基本形を使ってライオンと犬類を作ります。

Using mostly the same "base" as the Giraffe, but with an angle of different size. The same method can be adopted for Dogs.

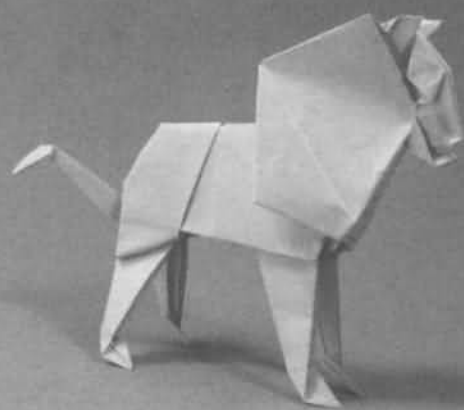

Created 1991 Paper 不切正方一枚折り: 1 piece

1

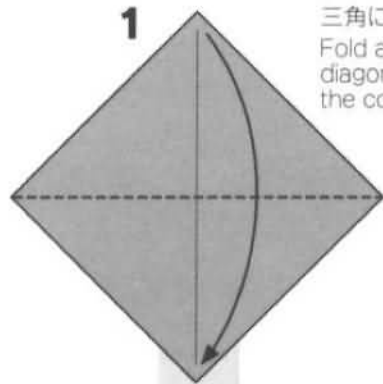

1
三角に折る
Fold along the diagonal, with the color inside.

2

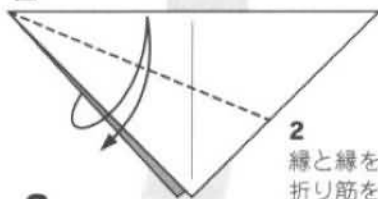

2
縁と縁を合わせて
折り筋をつける
Fold edge to edge.

3

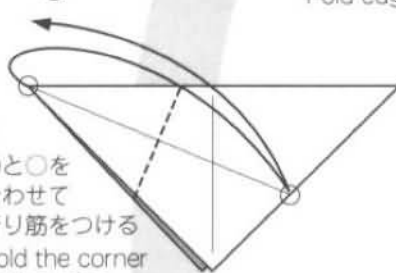

3
○と○を
合わせて
折り筋をつける
Fold the corner
to the edge.

4

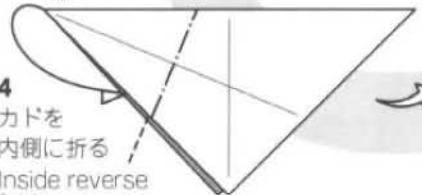

4
カドを
内側に折る
Inside reverse
fold.

5

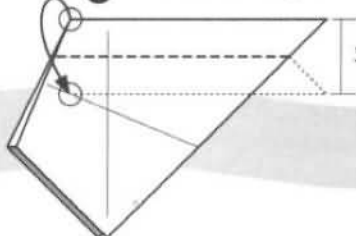

5
カドを折り筋に
合わせて平行に折る
Fold along the line
parallel to the top
horizontal edge.

平行

9

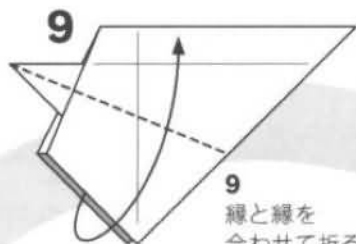

9
縁と縁を
合わせて折る
Fold edge to edge.

8

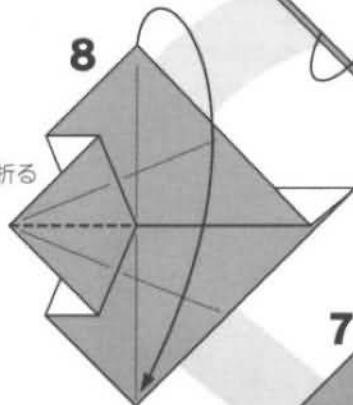

8
カドを下に折る
Fold down.

7

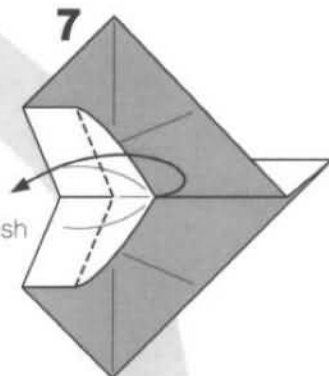

7
途中の図
Swivel and squash
the inner layer.

6

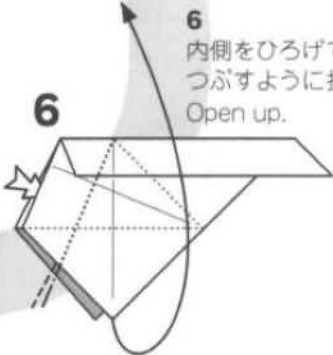

6
内側をひろげて
つぶすように折る
Open up.

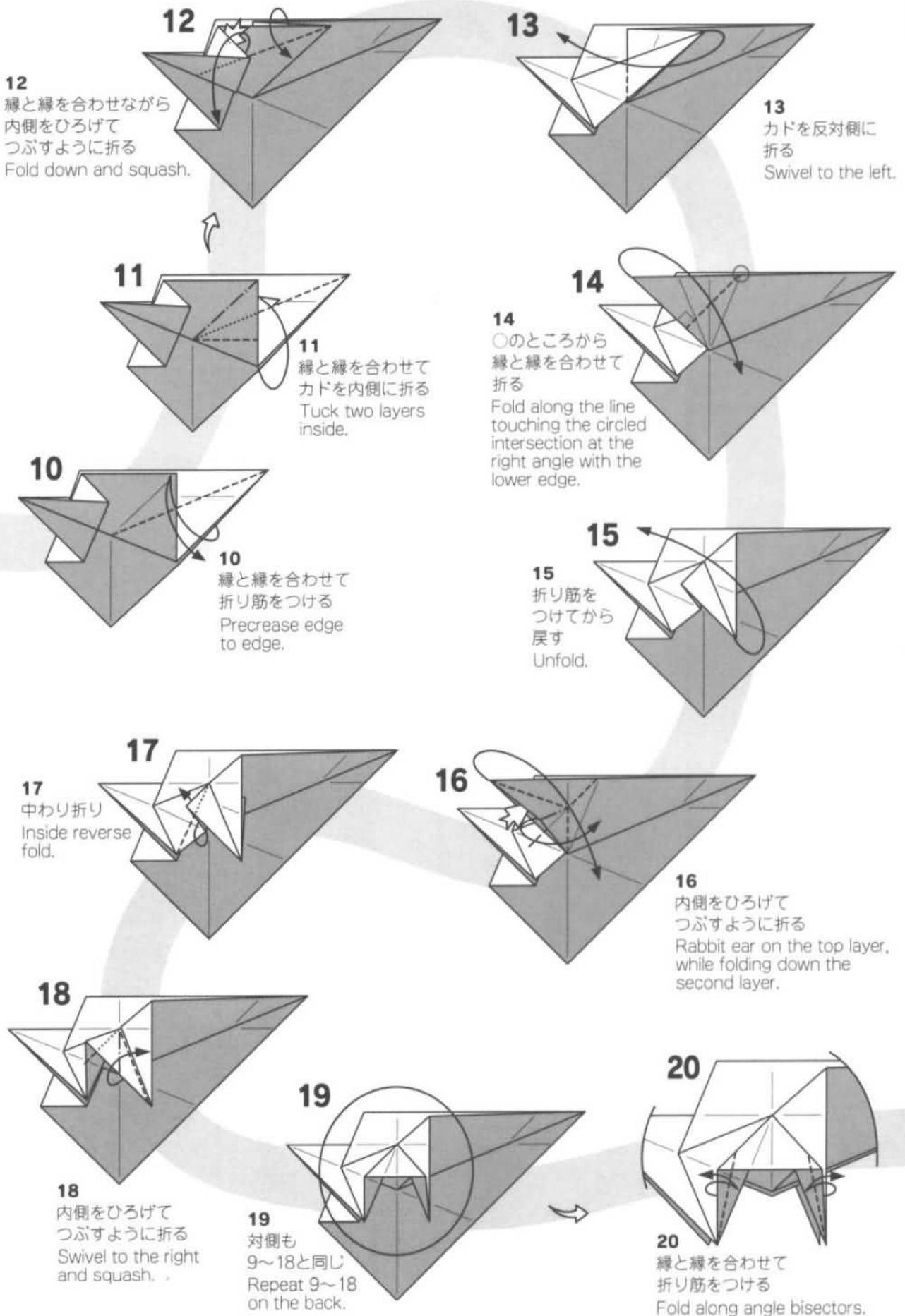

30
黒矢印の部分を
押しつぶす
ように折る
Squash the
arrowed part.

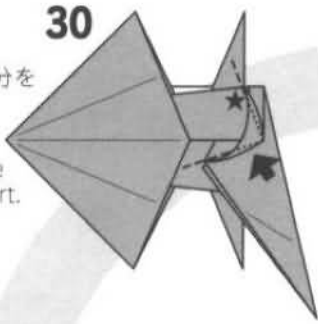

31

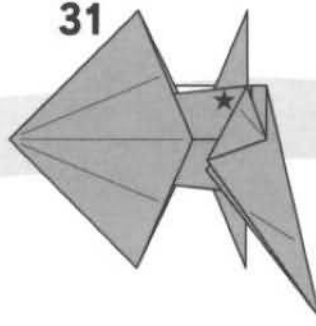

32

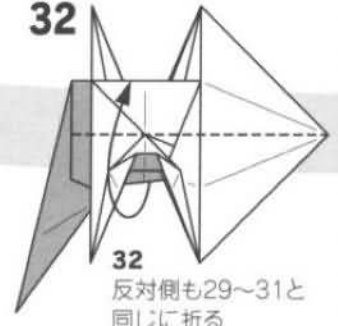

32
反対側も29~31と
同じに折る
Repeat 29~31 on
the back.

29

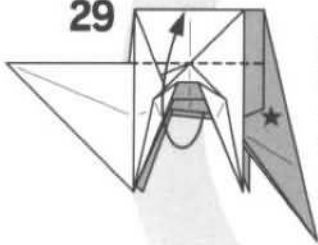

29
開くところで
上に折る
Swivel and open up.

27

縁をカドに合わせて
折り筋をつける
Fold the lower edge to
the corner.

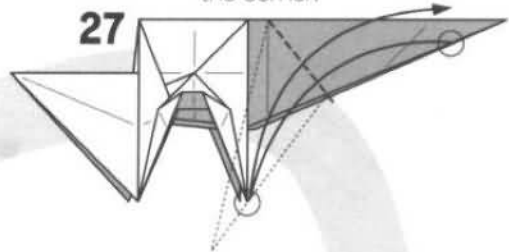

28

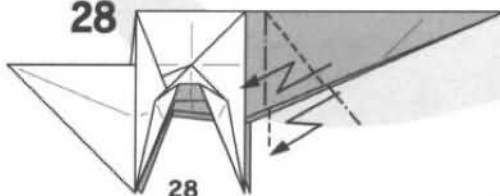

28
つけた折り筋で
内側に斜めに段折り
Pleat inside.

27

26

縁をカドに合わせて
折り筋をつける
Fold at a right angle.
Note that the bottom
edge has to touch the
circled intersection.

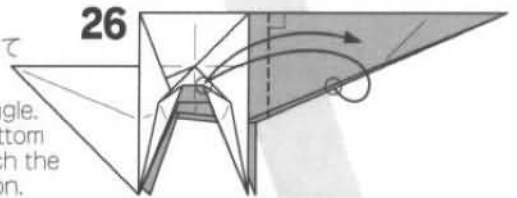

26

25

25
反対側も
23~24と同じ
Repeat 23~24
on the back.

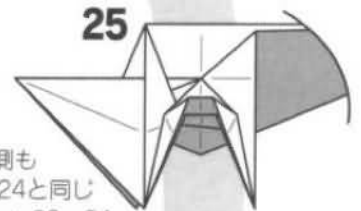

22

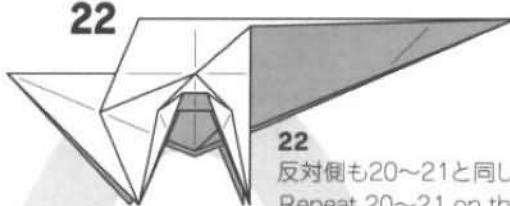

22
反対側も20~21と同じ
Repeat 20~21 on the
back.

21

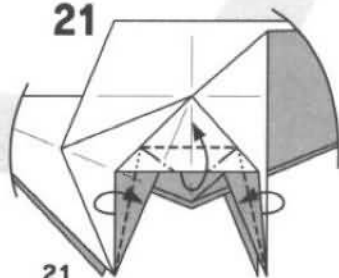

21
内側をひろげて
つぶすように折る
Swivel up and squash.

23

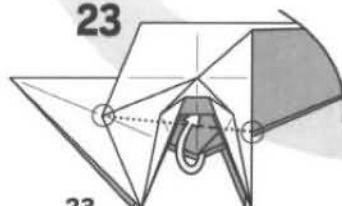

23
○と○を結ぶ線で
カドを内側に折り込む
Tuck the inner layer
inside.

24

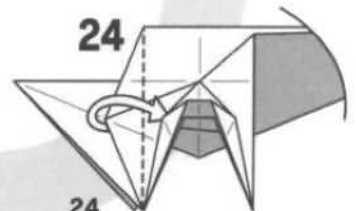

24
カドをすき間に
折り込む
Tuck the corner below
the first layer.

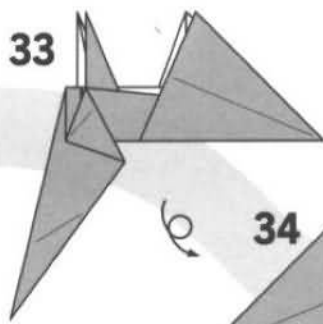

33

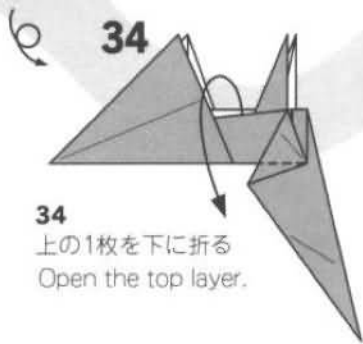

34
上の1枚を下に折る
Open the top layer.

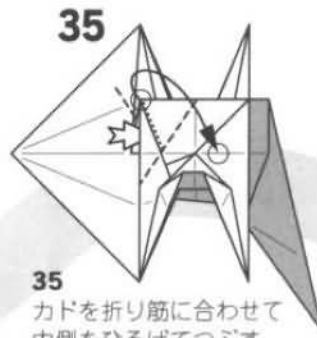

35
カドを折り筋に合わせて
内側をひろげてつぶす
ように折る
Fold down the corner
to the center line and
squash.

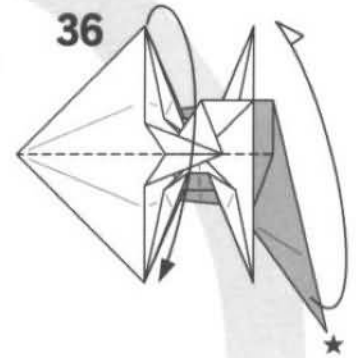

36
★のカドを後ろへ持ち上げ
ながらカドとカドを合わせて
半分に折る
Swivel the right colored
layers along with the body.

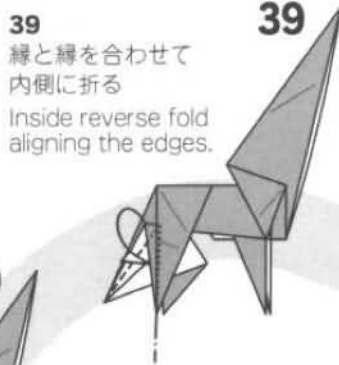

39
縁と縁を合わせて
内側に折る
Inside reverse fold
aligning the edges.

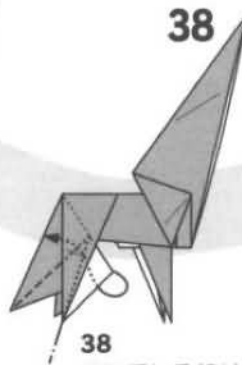

38
ついている折り筋を
使って中わり折り
Inside reverse fold
using pre-creases.



37
内側に斜めに
段折り
Pleat inside.



40
反対側も
38~39と同じ
Repeat 38~39
on the back.

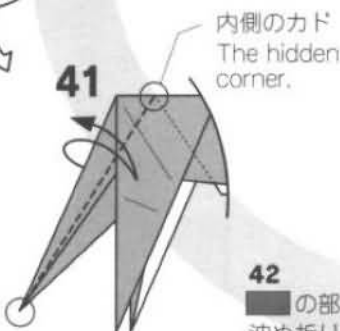

41
○と○を結ぶ線で
折り筋をつける
Pre-crease along the
line connecting the
circled points.

内側のカド
The hidden
corner.



42
■の部分
を沈め折り
(Closed sink)
Closed sink
the darkest
part



44
中わり折り
Sunk, Inside
reverse fold.



43
途中の図
Sinking ...

54
カドをひらく
ところで折る
Swivel down.



55

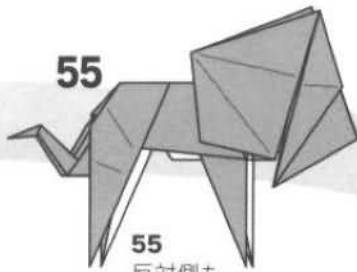

55
反対側も
53~54と同じ
Repeat 53~54
on the back.

56

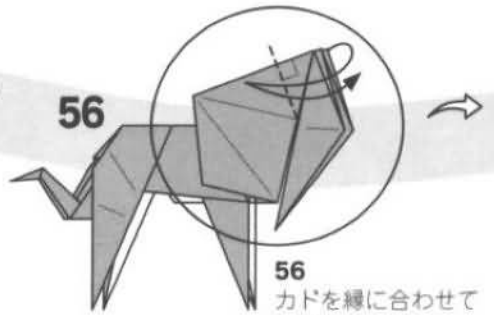

56
カドを縁に合わせて
折り筋をつける
Pre-crease at a
right angle.

53

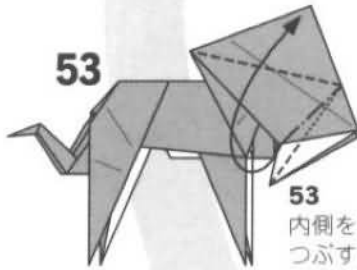

53
内側をひろげて
つぶすように折る
Open and squash.

51

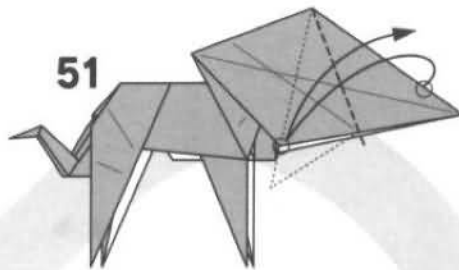

51
縁をカドに合わせて
折り筋をつける
Pre-crease the edge
to the corner.

52

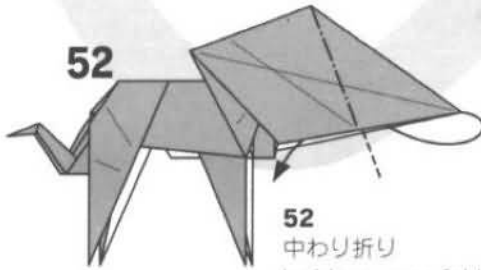

52
中わり折り
Inside reverse fold.

50

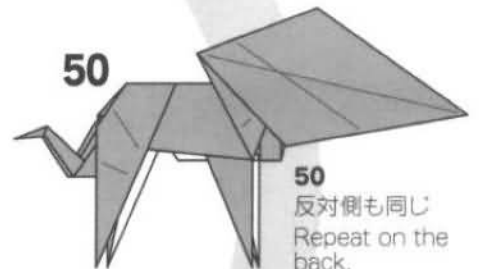

50
反対側も同じ
Repeat on the
back.

45



45
斜めに段折り
Pleat outside.

49

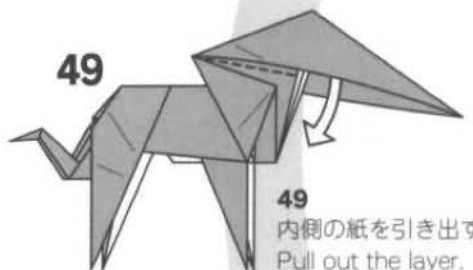

49
内側の紙を引き出す
Pull out the layer.

46

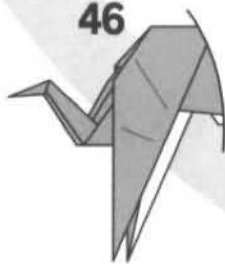

47

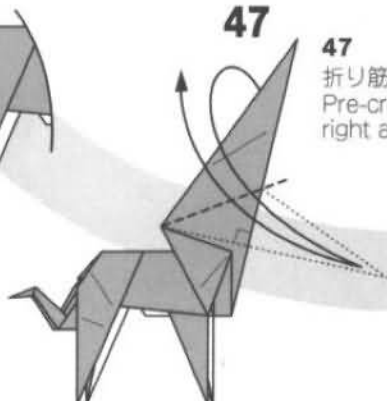

47
折り筋をつける
Pre-crease at a
right angle.

48

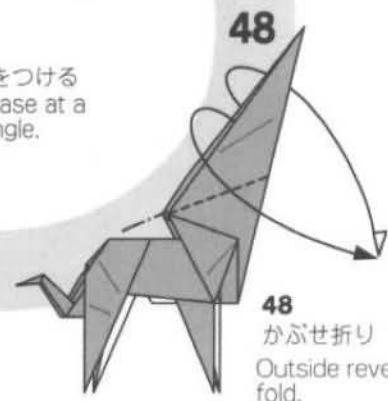

48
かぶせ折り
Outside reverse
fold.

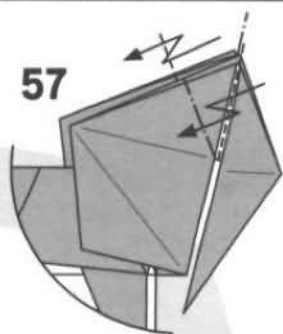

57

57
内側に斜めに
段折り
Pleat inside.

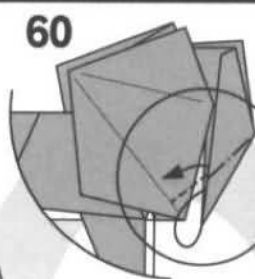

60

60
中わり折り
Inside reverse fold.

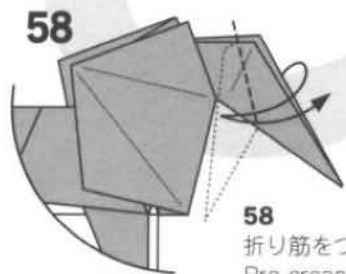

58

58
折り筋をつける
Pre-crease edge
to corner.

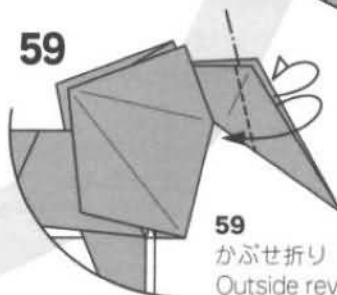

59

59
かぶせ折り
Outside reverse
fold.

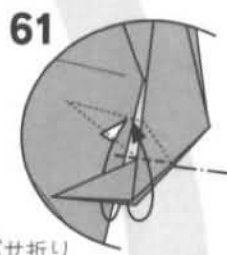

61

61
かぶせ折り
Outside reverse fold.

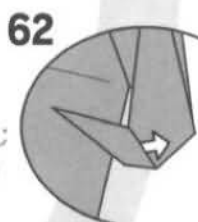

62

62
内側の紙を
引き出す
反対側も同じ
Pull out the
inner layer.

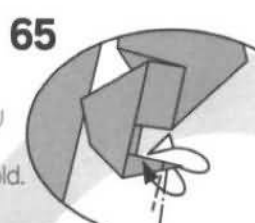

65

65
かぶせ折り
Outside
reverse fold.



64

64
中わり折り
Inside reverse
fold.

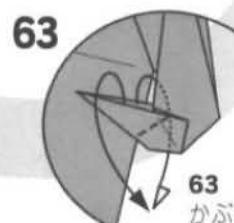

63

63
かぶせ折り
Outside reverse
fold.



66

66
上の1枚を
カドにかぶせる
Hide the complex
behind the layer
on the left.

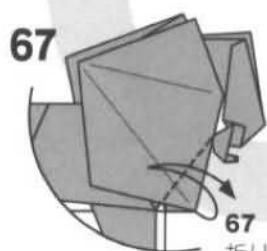

67

67
折り筋をつける
Pre-crease.

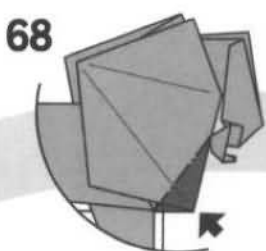

68

68
■の部分
を沈め折り
(closed sink)
Closed sink the
darkened part.

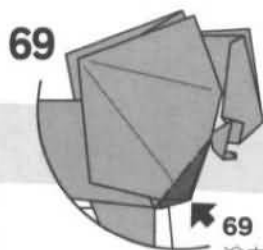

69

69
途中の図
Sinking ...

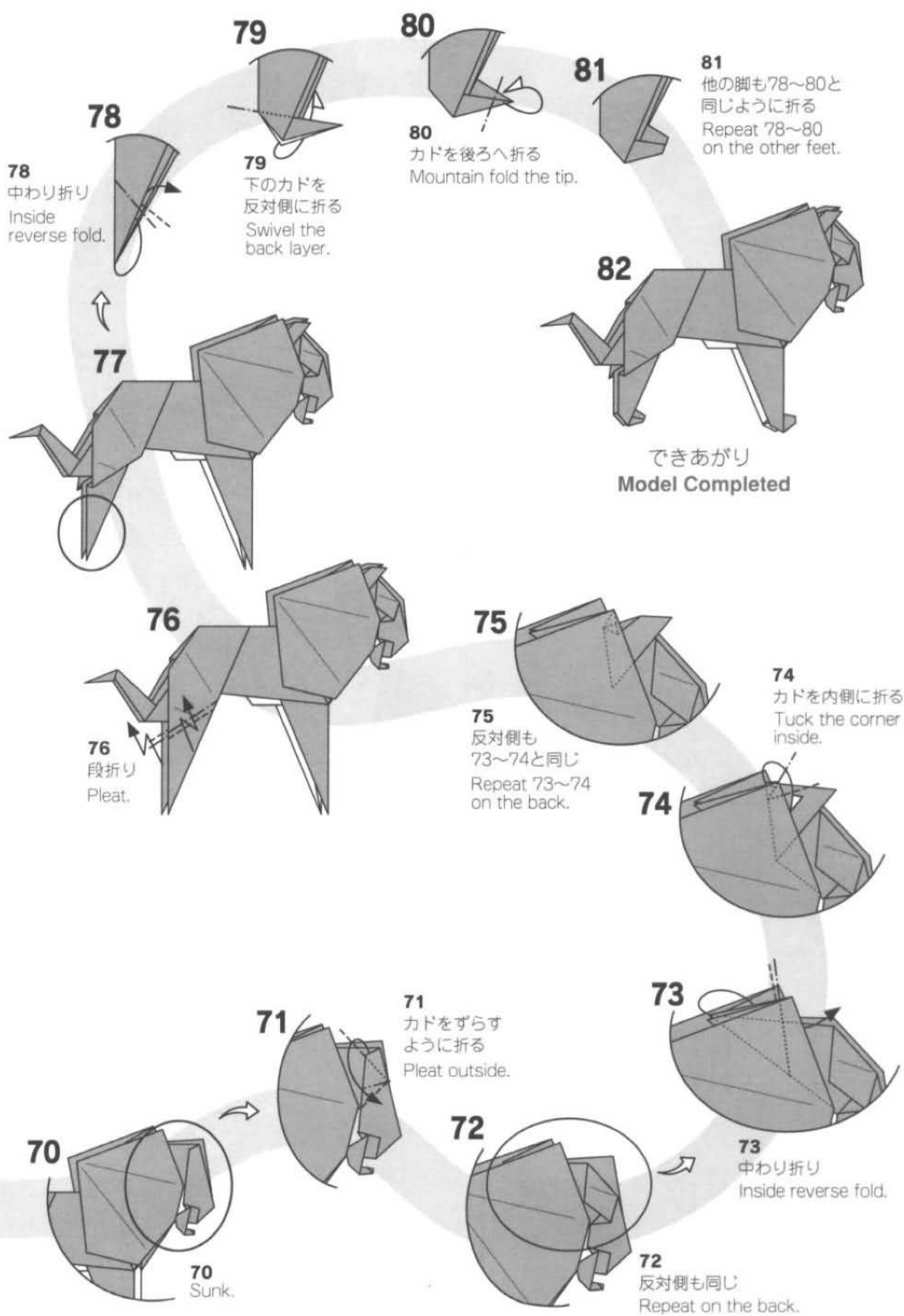

シェパード

Shepherd

犬の折り分けは、首のちょっとした角度、鼻先の長さなどデッサン力かものをいってしまいます。脚や耳の素材が長めに一通り揃うので、その後の作り分けは、犬のスケッチでもするように行います。

Dogs can distinguished from each other by an angle of a neck and the length of a muzzle. Such details must be finished with your ability in dessin as your only aid. The "base" provides you with enough amount of paper for legs and ears, so the rest is all up to you.

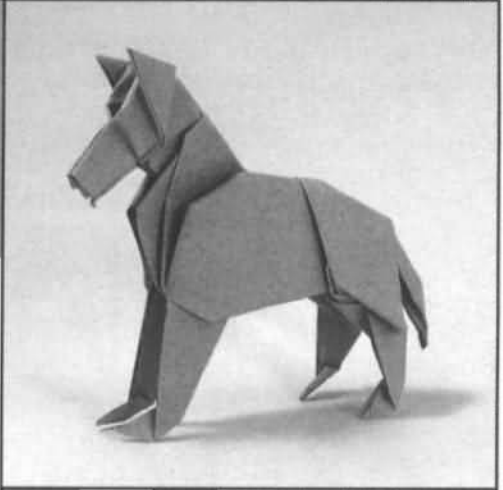

Created 1996 Paper 不切正方一枚折り: 1 piece

P. 80 [ライオン] の23の形からはじめる
Start with No. 23 of [Lion] (P. 80)

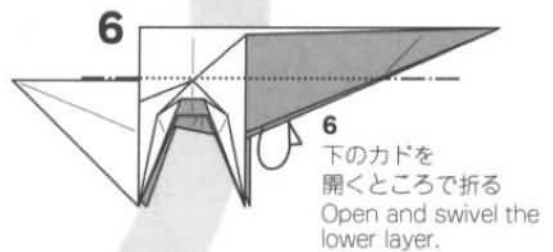
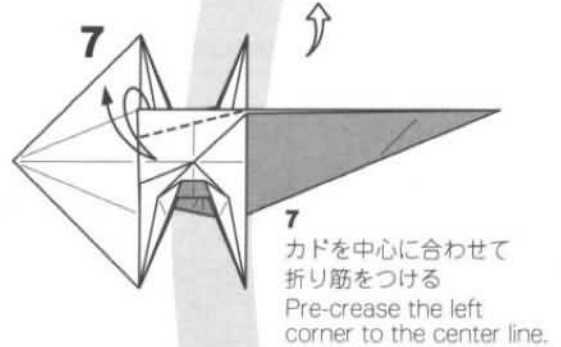
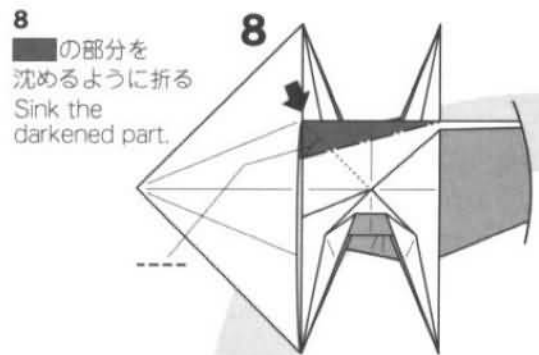
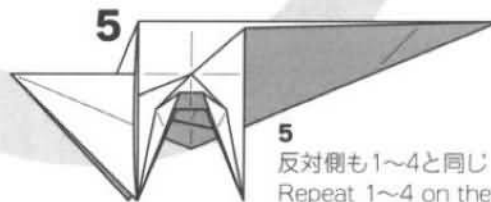
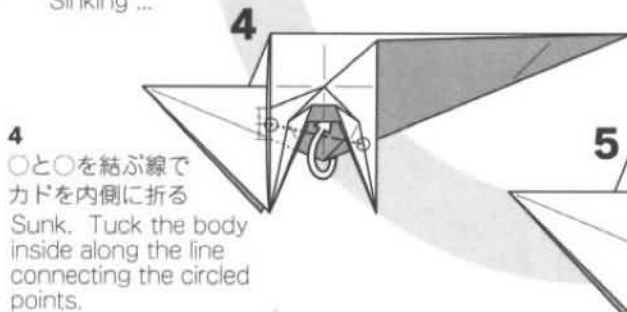
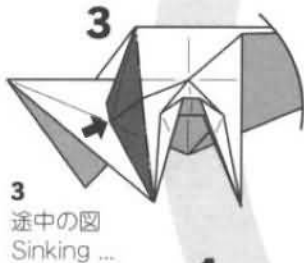
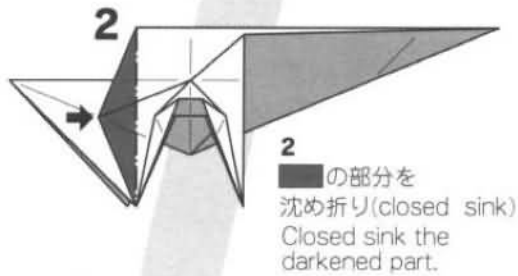
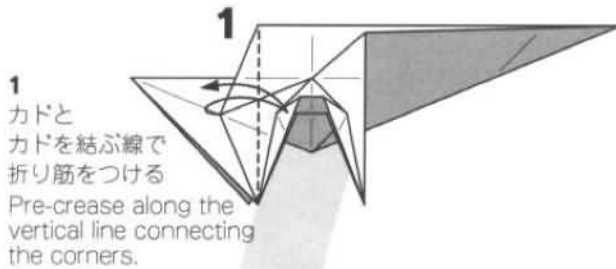

10
 線のところでカドを
 反対側に折る
 Sink. Fold along
 the edge.

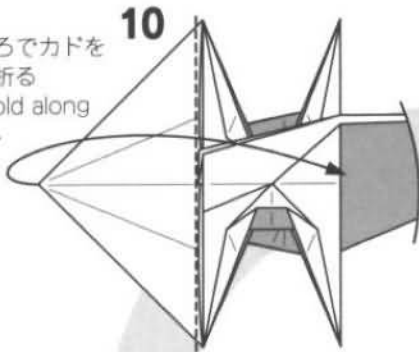

11
 1/4のところでカドを
 反対側に折る
 Valley fold at the point one
 fourth of the length of the
 center line of the triangle.

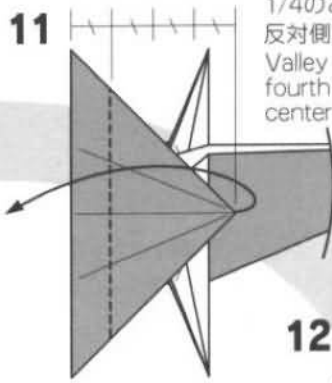

12
 中心に合わせて
 引き寄せるように折る
 Fold the edges to the
 center and squash.

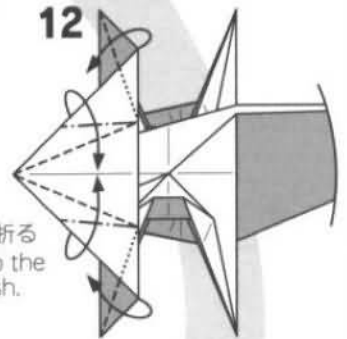

9
 途中の図
 Sinking ...

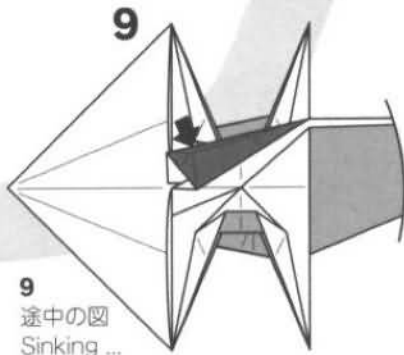

13
 下の縁に
 合わせて
 引き寄せる
 ように折る
 Fold along the
 edge and squash.

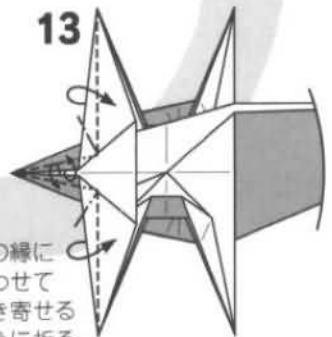

14
 それぞれカドを
 反対側に折る
 Swivel to the left.

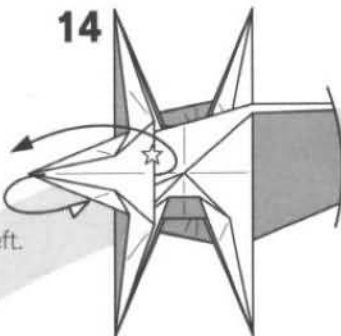

13
 下の縁に
 合わせて
 引き寄せる
 ように折る
 Fold along the
 edge and squash.



15
 下のカドを
 出しながら
 ☆の線を
 内側に差し込む
 Tuck the starred
 edge inside,
 while swiveling
 back.

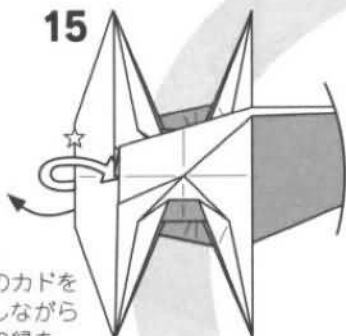

17
 カドを縁に合わせて
 折り筋をつける
 Pre-crease at a right angle.

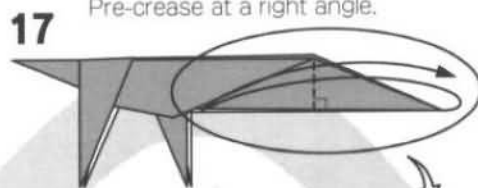

16
 カドとカドを
 合わせて折る
 Fold corner to corner.

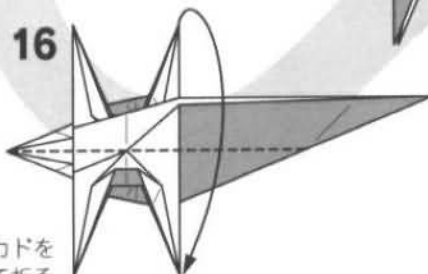

18
 折り筋を縁に合わせて
 折り筋をつける
 Pre-crease aligning the
 vertical crease line to
 the bottom edge.



29

カドを縁と合わせて
折り筋をつける
Pre-crease at a
right angle.

29

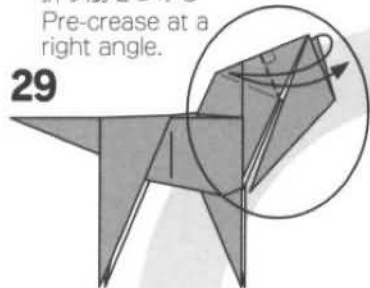

30

30
内側に斜めに段折り
Pleat inside.

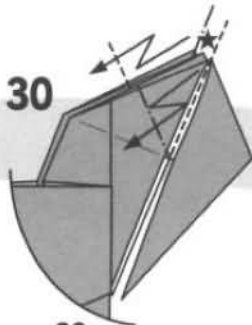

31

31
内側のカドを引き出す
反対側も同じ
Pull out the inner layers.

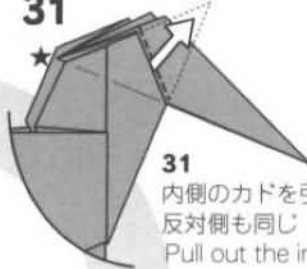

28

28
内側に斜めに段折り
Pleat inside.

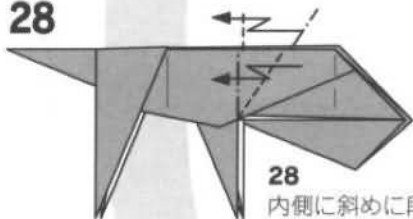

32

32
開くところで
カドを折る
Swivel down.

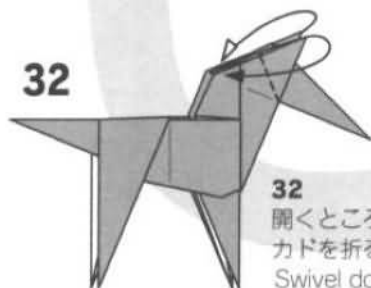

27

27
○と○を合わせて
折り筋をつける
Pre-crease aligning the
circled lines.

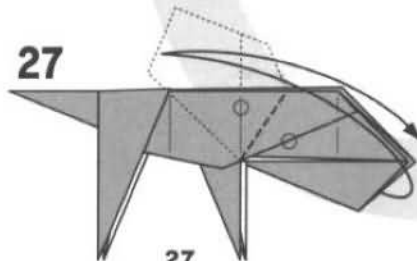

26

26
縁のところで
折り筋をつける
Pre-crease along
the edge.

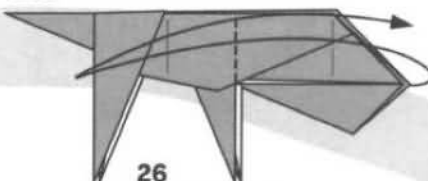

25

25
反対側も21~24と同じ
Repeat 21~24 on the
back.

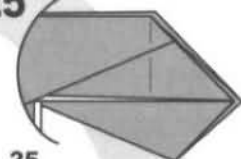

21

21
内側のカドを引き出す
Pull out the inner layer.

21

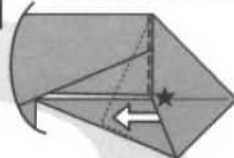

20

20
中わり折り
Inside reverse fold.

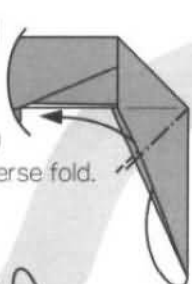

24

24
そのままカドを
反対側に折る
Swivel to the right.

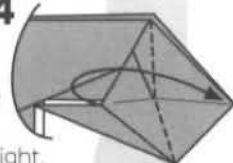

19

19
つけた折り筋で
かぶせ折り
Outside reverse fold.

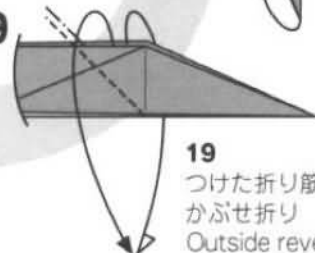

22

22
途中の図
21 lets the complex
open lightly.

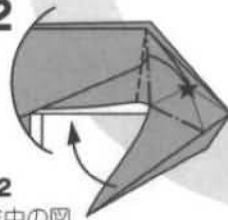

23

23
カドを押し込む
ように折る
Push the arrowed part
down.

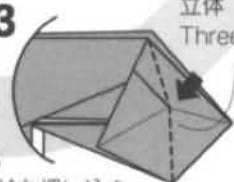

立体
Three-dimensional.

34

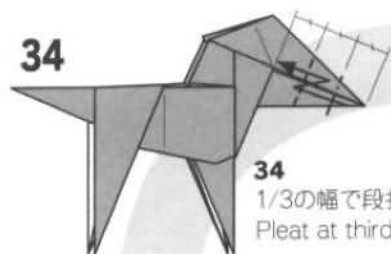

34
1/3の幅で段折り
Pleat at thirds.

35

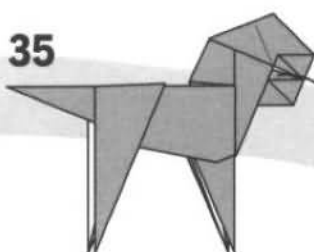

35
折り筋をつけて
から戻す
Unfold.

36

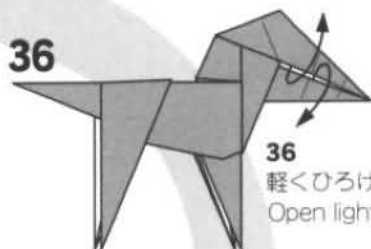

36
軽くひろげる
Open lightly.

33

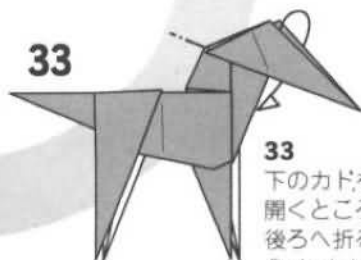

33
下のカドを
開くところで
後ろへ折る
Swivel down the
back layer.

37

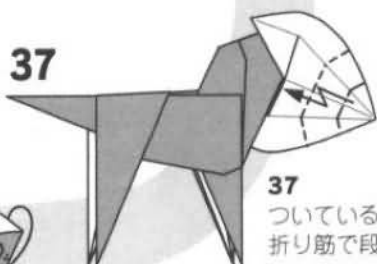

37
ついている
折り筋で段折り
Pleat using the
crease lines.

38



38
ついている折り筋で
引き寄せるように
折りまとめる
Reassemble using
the crease lines.

39

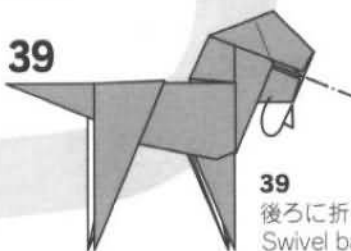

39
後ろに折る
Swivel back.

46



46
斜めに
段折り
Pleat.

40

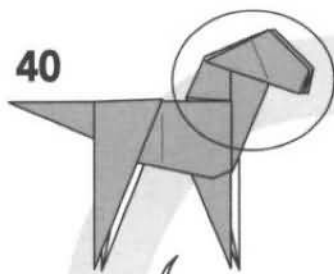

41

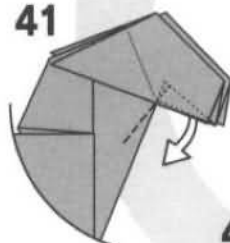

41
内側のカドをつまんで
ずらすように折る
Pull out the hidden
corner.

45

45
カドを内側に折る
反対側も同じ
Mountain fold
the corners.

45

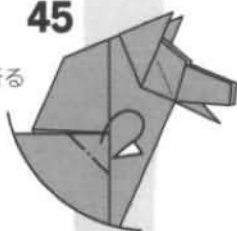

42

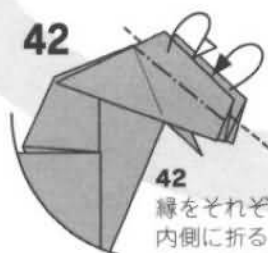

42
縁をそれぞれ
内側に折る
Tuck the edges inside.

43



43
カドを斜めに
折り上げる
反対側も同じ
Swivel the ears up.

44

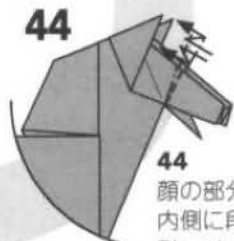

44
顔の部分を
内側に段折り
Pleat inside.

49
カドをそれぞれ
内側に折る
Tuck inside
the corners.

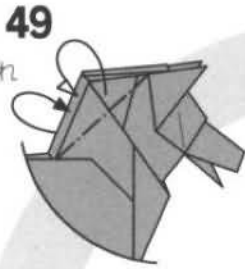

50
カドをかぶせるように
内側に折り込む
Tuck inside while forming
an outside reverse fold.

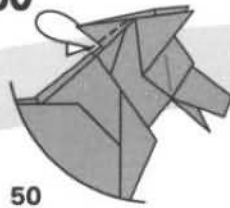

51
中わり折り
Inside reverse
fold.

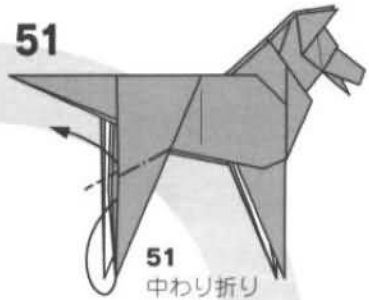

48
つけた折り筋で
沈めるように
内側に段折り
Pleat inside using
the crease lines.

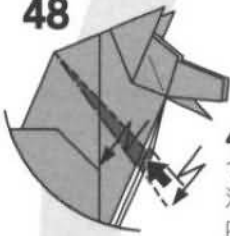

52
中わり折り
Inside reverse
fold.

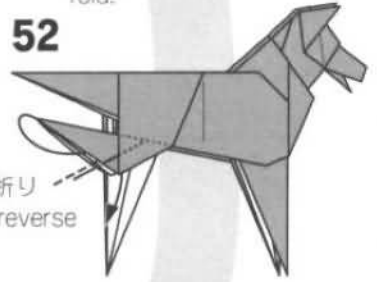

47
折り筋をつけてから
46の形に戻す
Unfold.



54

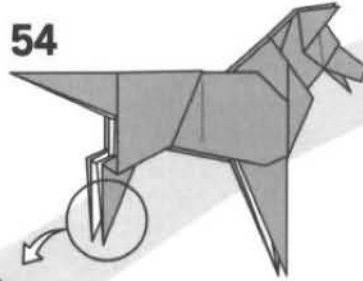

53
反対側も
51~52と同じ
Repeat 51~52
on the back.

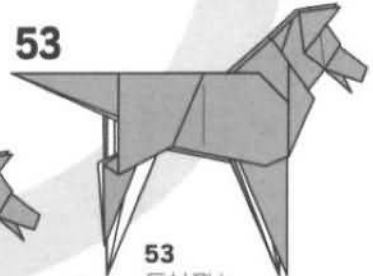

55
中わり折り
Inside reverse
fold.



61
できあがり
Model Completed



56
下のカドを
反対側に折る
Swivel the back
layer.

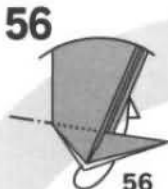

57
カドを後ろへ折る
Mountain fold
the tip.

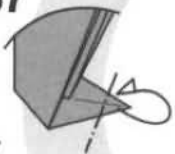

58
他の脚も
55~57と
同じように折る
Repeat on the
other feet.



59
中わり折り
Inside reverse fold.

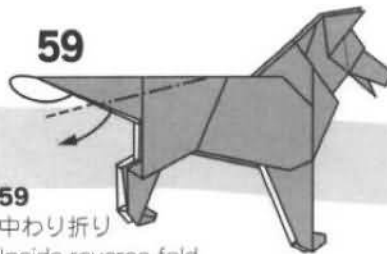

60
かぶせ折り
Outside reverse fold.

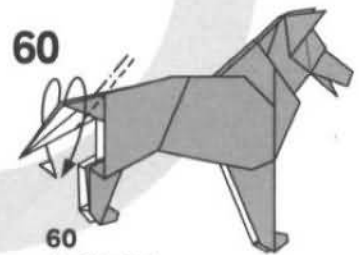

ブードル

Poodle

犬類の2つめは、足先や尻尾の先のボリュームが特徴的なブードルです。二辺に仕込みをして足先や尻尾の先にボリュームを与えます。

A poodle must be done with an emphasis on the legs and the tail. Extra layers made in the beginning do this.

Created 1996 Paper 不切正方一枚折り: 1 piece

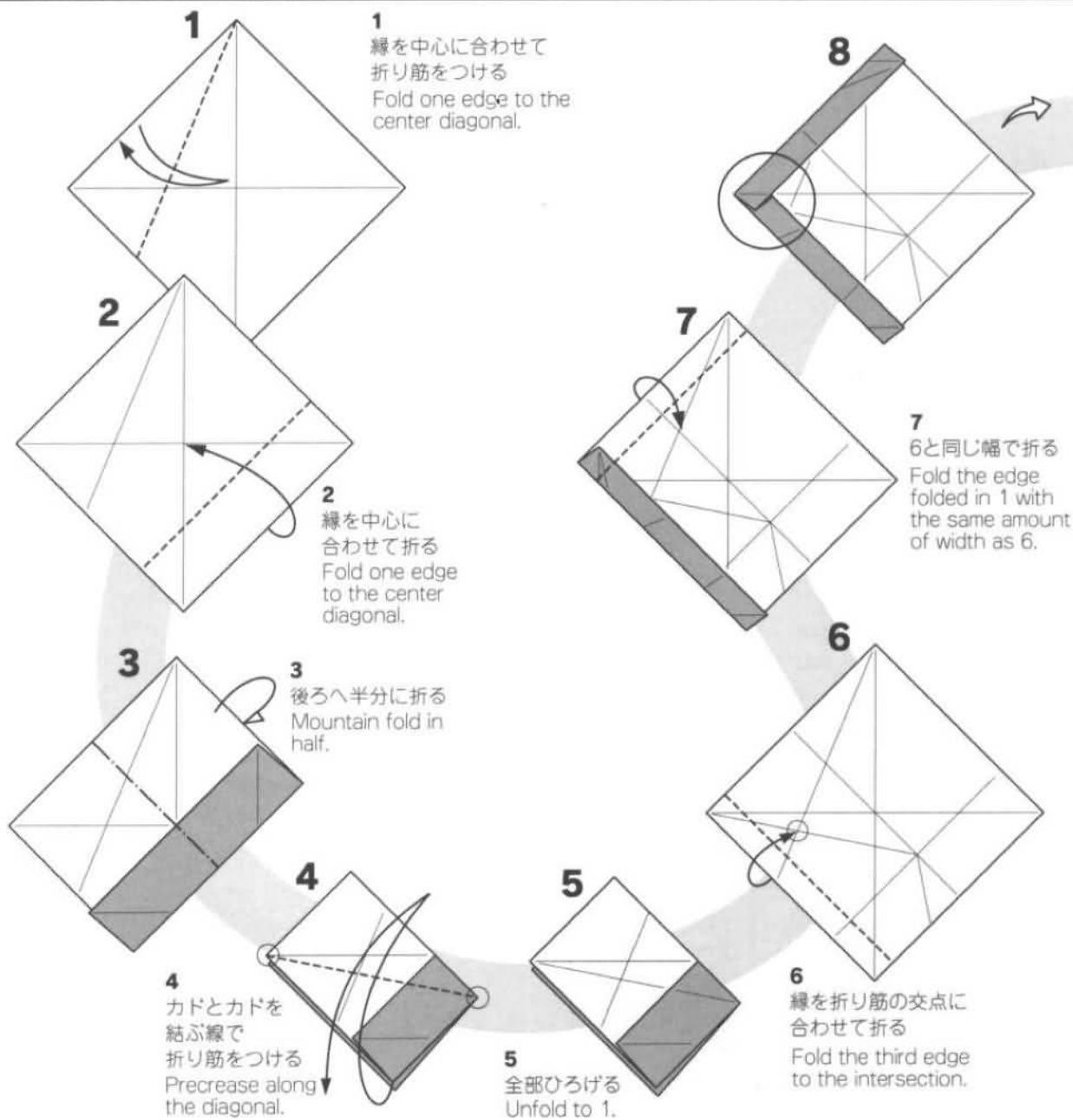

11
カドを上折る
Swivel up.

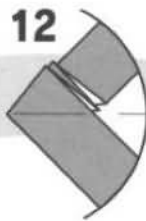
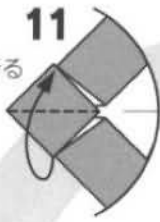

13
後ろへ三角に折る
Mountain fold
in half at the
diagonal.

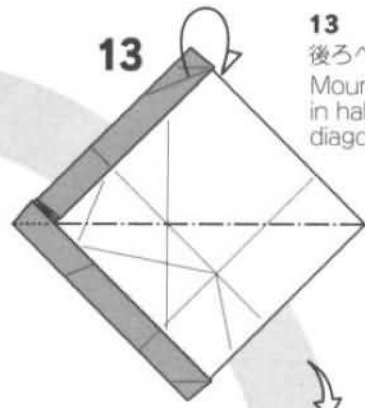

10

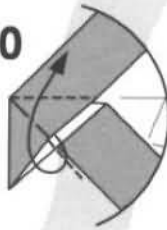

10
内側をひろげて
つぶすように折る
Open and squash.

14

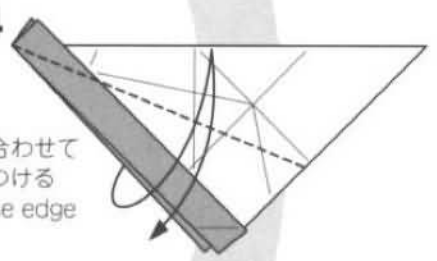

14
縁と縁を合わせて
折り筋をつける
Pre-crease edge
to edge.

9

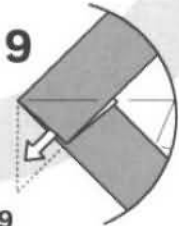

9
内側のカドを
引き出して
つまむように折る
Pull out the corner.

15

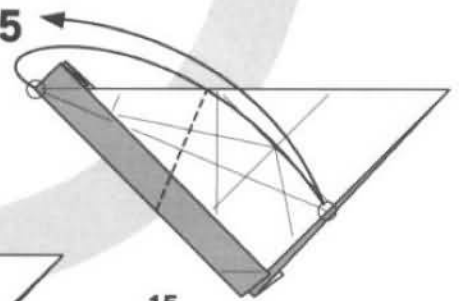

15
○と○を合わせて
折り筋をつける
Pre-crease so that
the circled ends
touch each other.

16

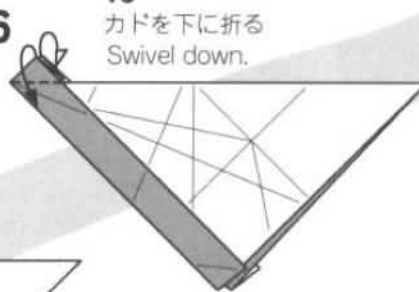

16
カドを下に折る
Swivel down.

17

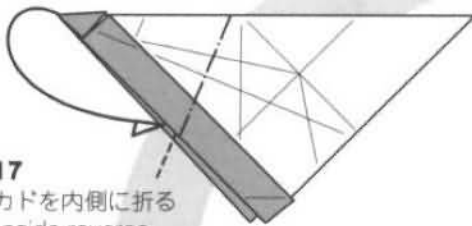

17
カドを内側に折る
Inside reverse
fold.

18

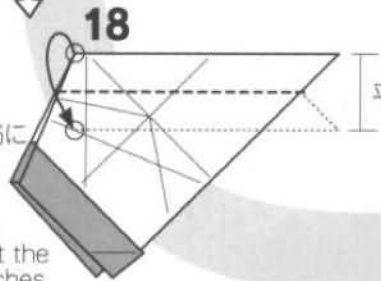

18
カドを折り筋に
合わせて
平行に折る
Fold the top
edge so that the
left end touches
the line made in 14 and
the crease line becomes
parallel with the top edge.

19

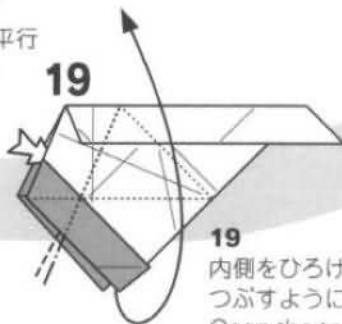

19
内側をひろげながら
つぶすように折る
Open the top layer.

20

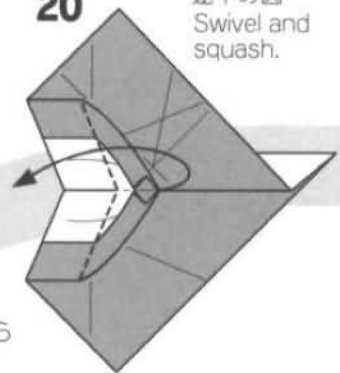

20
透中の図
Swivel and
squash.

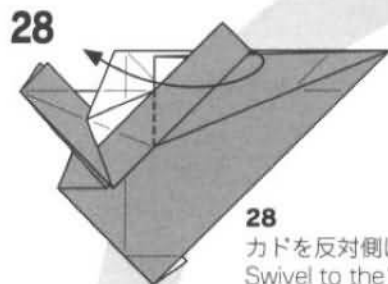

28
カドを反対側に折る
Swivel to the left.

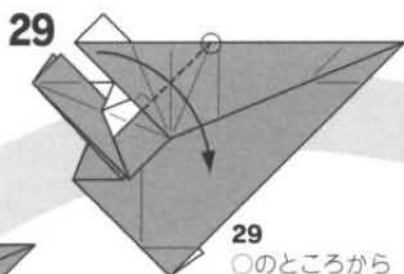

29
○のところから
線と線
合わせて折る
Fold along the
hidden edge.
Note the end of
the crease line.

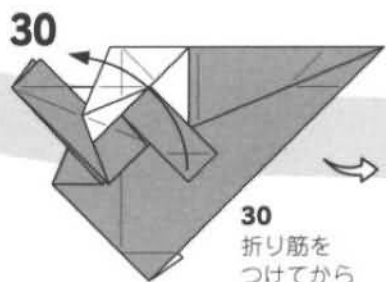

30
折り筋を
つけてから
戻す
Unfold.

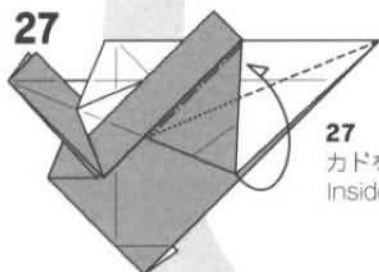

27
カドを内側に折る
Inside reverse fold.

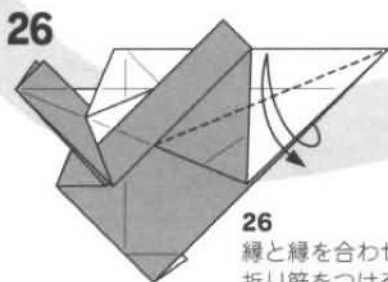

26
線と線に合わせて
折り筋をつける
Fold edge to edge.

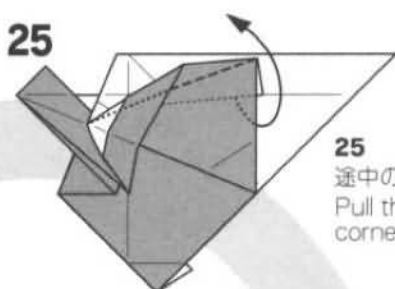

25
途中の図
Pull the hidden
corner up.

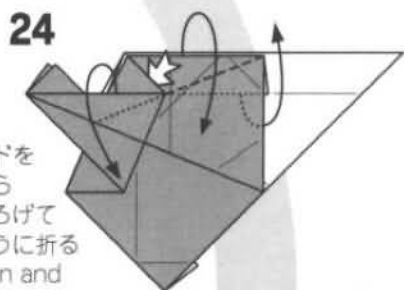

24
後ろのカドを
出しながら
内側をひろげて
つぶすように折る
Fold down and
squash.

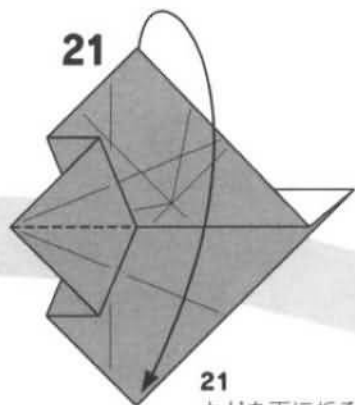

21
カドを下に折る
Close back.



22
ついている
折り筋で折る
Swivel up on the
back side.

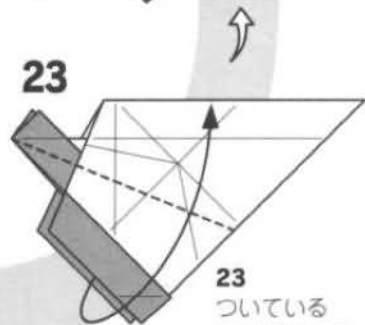

23
ついている
折り筋で折る
Fold up using the
pre-crease.

31

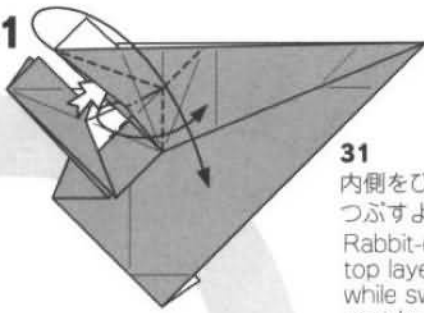

31
内側をひろげて
つぶすように折る
Rabbit-ear on the
top layer,
while swiveling the
next layer down.

40

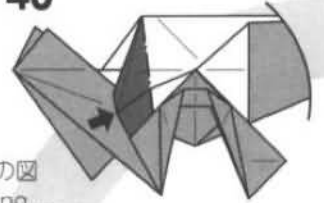

40
途中の図
Sinking ...

32

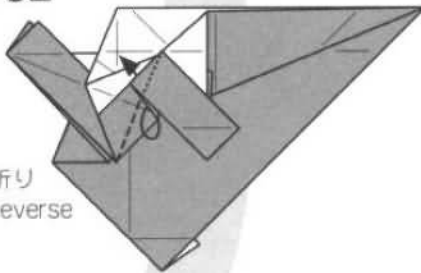

32
中わり折り
Inside reverse
fold.

39

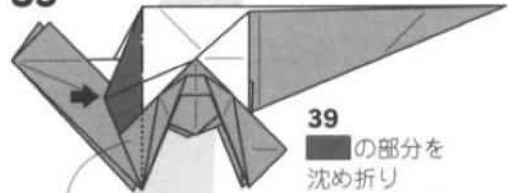

39
この部分は
内側だけ折る
The part to be sunk
is hidden under.

39
■の部分
を沈め折り
(closed sink)
Closed sink the
darkened part.

33

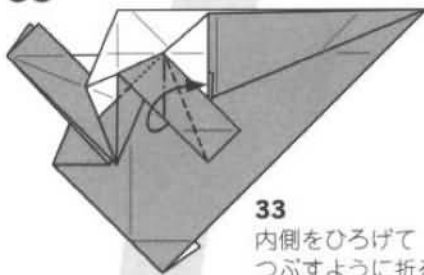

33
内側をひろげて
つぶすように折る
Open and squash.

38

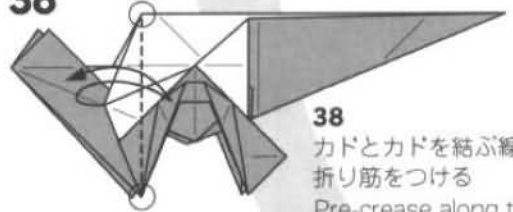

38
カドとカドを結ぶ線
で折り筋をつける
Pre-crease along the
line connecting the top
and bottom corners.

34

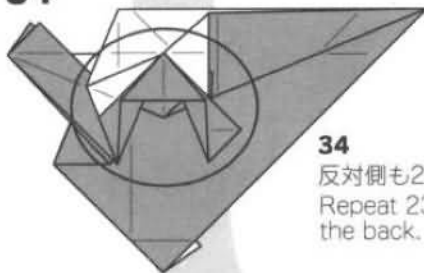

34
反対側も23~33と同じ
Repeat 23~33 on
the back.

37

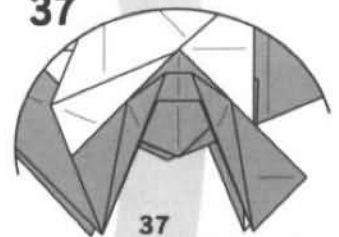

37
反対側も35~36と同じ
Repeat 35~36 on
the back.

35

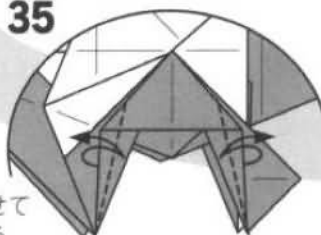

35
縁と縁を合わせて
折り筋をつける
Fold edge to edge.

36

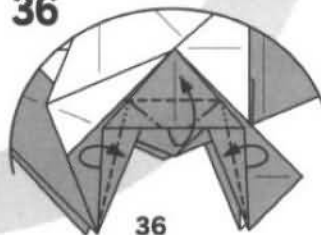

36
内側をひろげて
つぶすように折る
Swivel and squash.

41

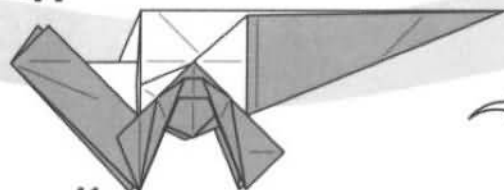

41
反対側も38~40と同じ
Sunk.
Repeat 38~40 on
the back.

42

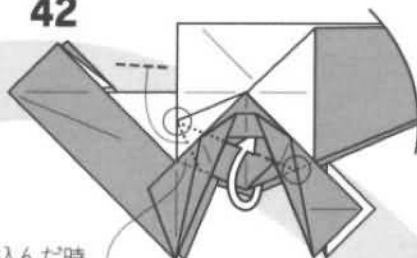

42
○と○を結ぶ線で
カドを内側に
折り込む
Tuck the body
inside along the line
connecting the
circled points.

折り込んだ時
内側である部分を
あらかじめ折っておく
The excess layer of
paper should be
pleated beforehand.

43

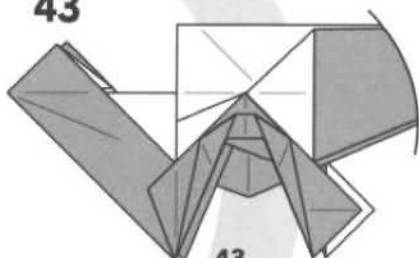

43
反対側も同じ
Repeat on the
back.

45

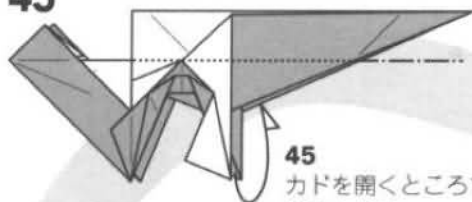

45
カドを開くところで
後ろへ折る
Open the back
layers.

44

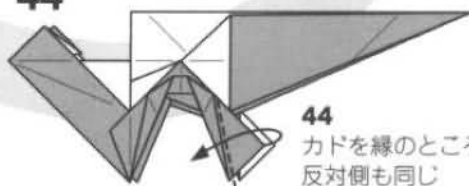

44
カドを縁のところで折る
反対側も同じ
Fold along the edge.
Repeat on the back.

46

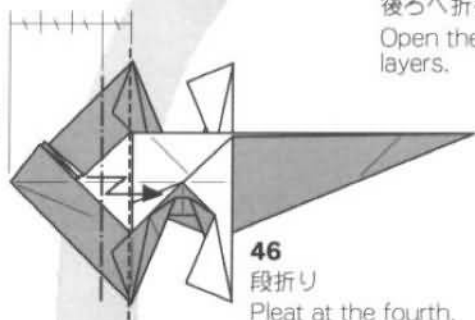

46
段折り
Pleat at the fourth.

47

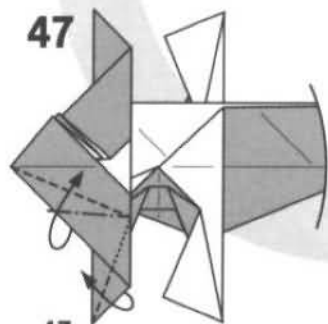

47
中心に合わせて
引き寄せる
ように折る
Swivel and squash.

48

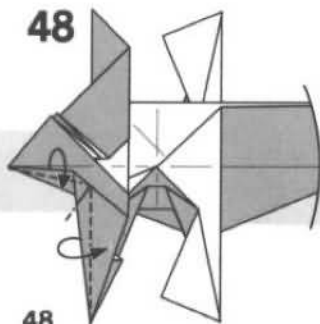

48
下の縁のところで
引き寄せるように折る
Fold along the edge
and squash.

49

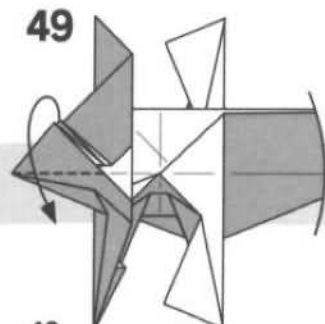

49
カドを2枚重ねて
反対側に折る
Fold down two layers.

57

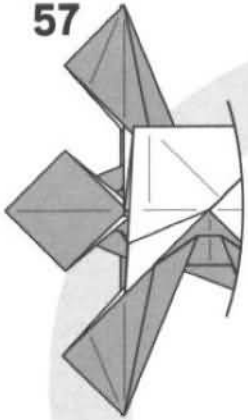

58

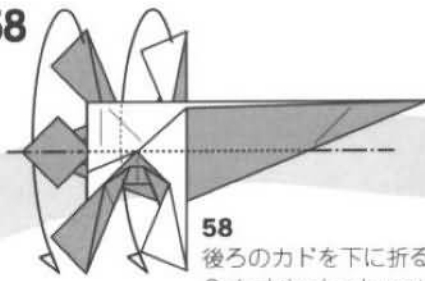

58
後ろのカドを下に折る
Swivel the back part
down.

59

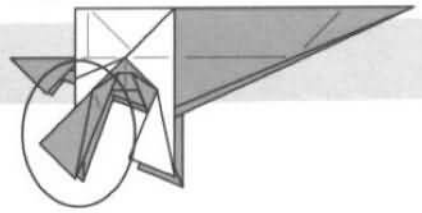

54

引き出したカドを反対側に
折りながら下のカドを出す
Swivel back along with the
corners revealed in 53.

56

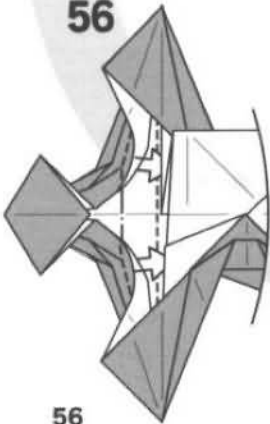

56
★の部分を内側に
差し込みながら
折りまとめる
Note that a kind of
sink is formed.

55

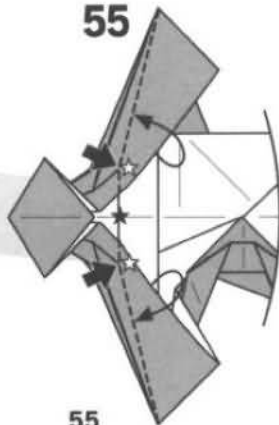

55
☆のカドの部分を
押し込みながら
縁を裏返すようにする
Push the starred hidden
corners inside...

54

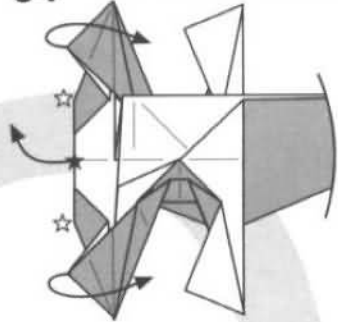

53

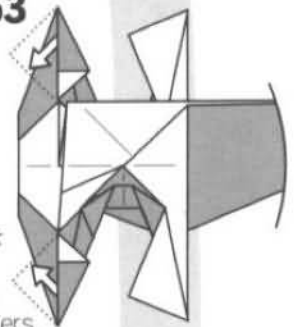

53
内側のカドを
引き出す
Pull out the
hidden corners.

50

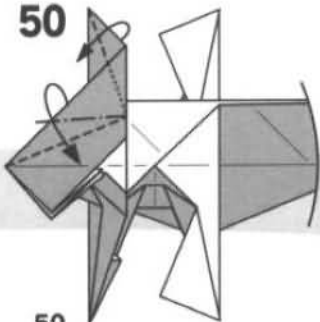

50
反対側も47~48と同じ
Repeat 47~48 on the
top side.

51

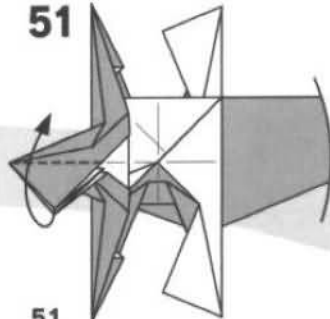

51
カドを上折る
Fold up one layer.

52

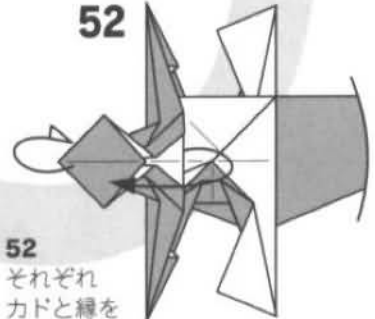

52
それぞれ
カドと縁を
反対側に折る
Swivel to the left.

60

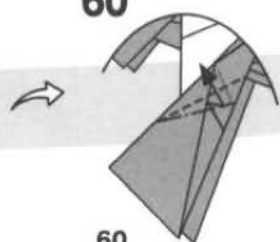

60
斜めに段折り
Pleat outside.

61



61
引き寄せるように
折って細くする
Fold edge to edge
and squash.

62



62
反対側も
60~61と同じ
Repeat 60~61
on the back.

63

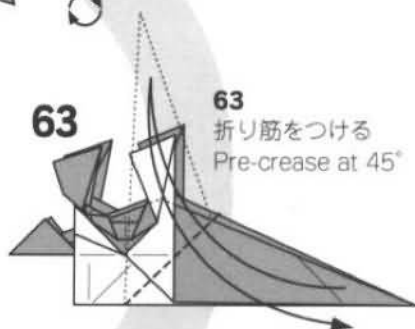

63
折り筋をつける
Pre-crease at 45°

65

65
縁を折り筋に
あわせて折る
Fold edge to
edge.

65

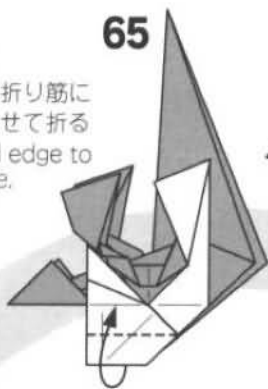

64

64
中わり折り
Inside reverse
fold.

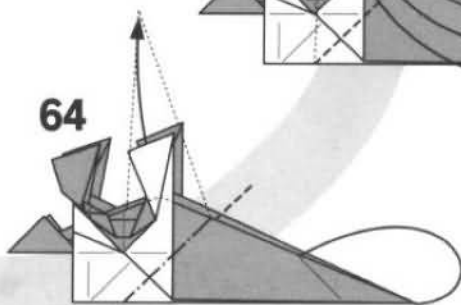

66

66
内側をひろげながら
縁のところでカドを
反対側に折る
Fold down.
The head part will
be pulled open.

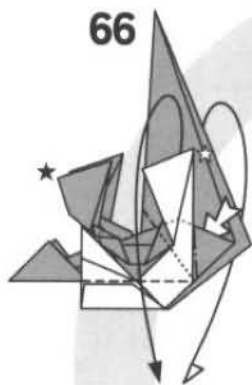

67

67
つられて持ち上がる
部分は立体のまま
カドをかぶせ折り
してつぶすように折る
While keeping the head
part three-dimensional,
form an outside-reverse
fold.

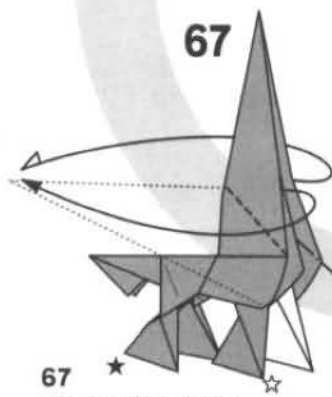

68

68
かぶせ折り
Another outside
reverse fold.

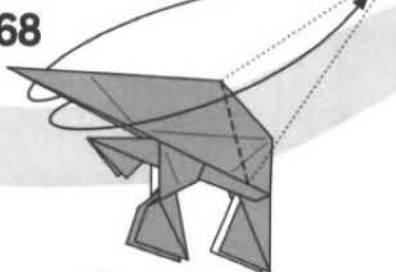

69

69
中わり折り
Inside reverse
fold.

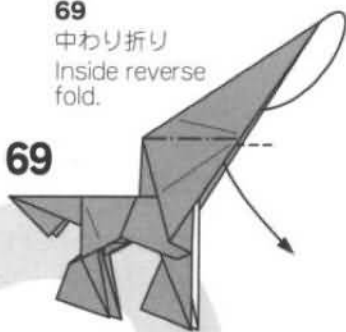

70

70
下のカドを
後ろへ折る
Swivel down
the back part.

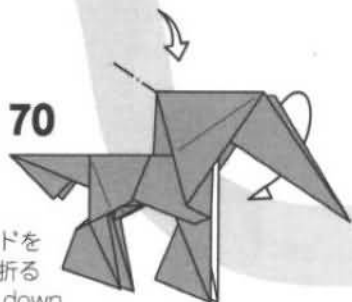

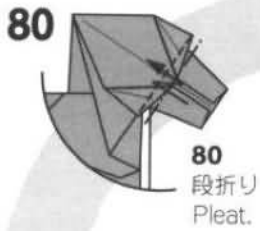

80
段折り
Pleat.

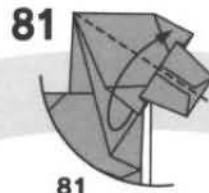

81
カドとカドを
合わせて折る
Fold up the
head in half.

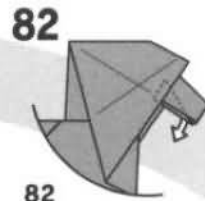

82
内側のカドを
つまんで
ずらすように折る
Slide down the jaw.

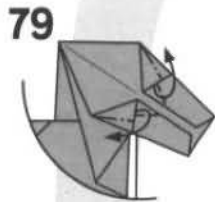
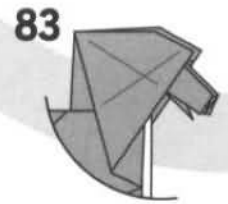

79
内側をひろげて
つぶすように折る
Squash.

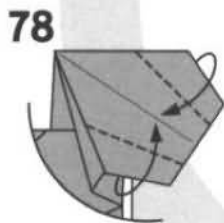

78
縁を折り筋に
合わせて折る
Fold edge to
edge.

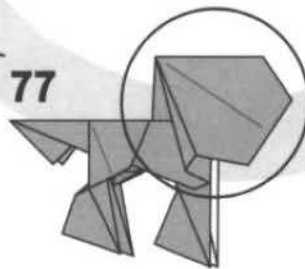

77

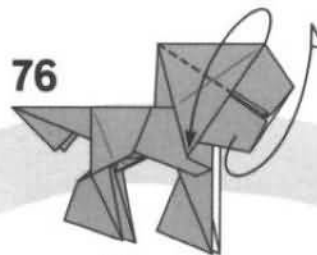

76
それぞれカドを
反対側に折る
Swivel down.



75
ついている折り筋で
引き寄せるように
折りまとめる
Assemble back using
the crease lines.

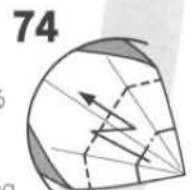

74
ついている
折り筋で
段折り
Pleat using
the crease lines.

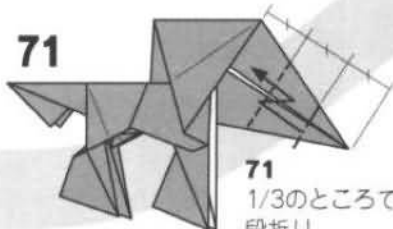

71
1/3のところで
段折り
Pleat at thirds.

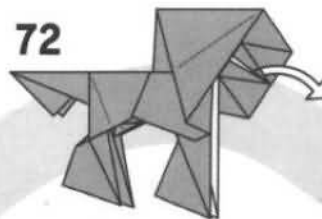

72
しっかりと
折り筋を
つけてから戻す
Unfold.

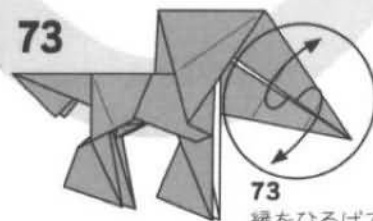

73
縁をひろげて
内側を見る
Open and look
inside.

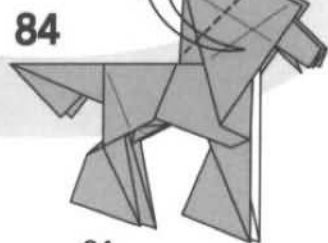

84

84
斜めにしっかりと
折り筋をつける
Precrease tightly.

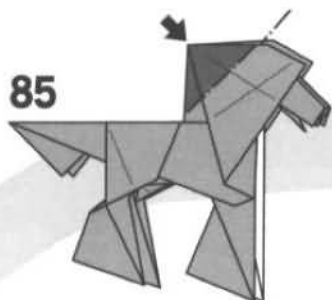

85

85
■の部分
を沈め折り
Sink the
darkened part.

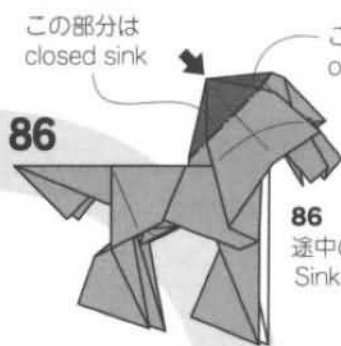

86

この部分は
closed sink

この部分は
open sink

86
途中の凹
Sinking ...

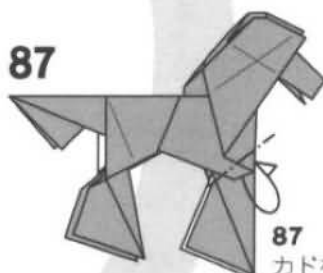

87

87
カドを内側に折る
反対側も同じ
Tuck inside.
Repeat on
the back.

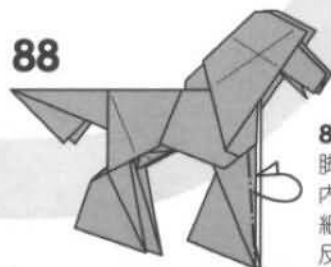

88

88
脚の縁を
内側に折って
細くする
反対側も同じ
Narrow the
front legs.

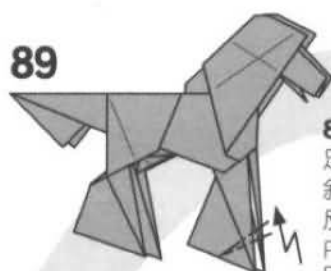

89

89
足の先を
斜めに段折り
反対側も同じ
Pleat inside.
Repeat on
the back.

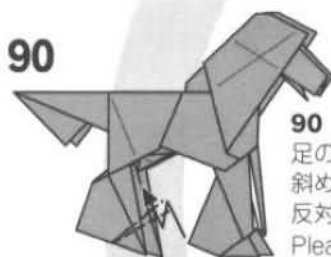

90

90
足の先を
斜めに段折り
反対側も同じ
Pleat inside.
Repeat on the back.

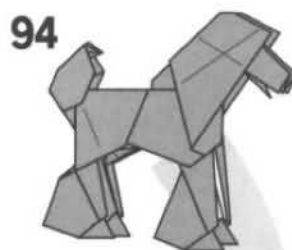

94

できあがり
Model Completed

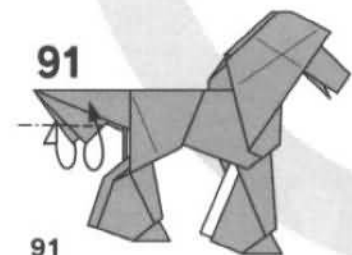

91

91
カドを上
に折る
Fold the tips up.

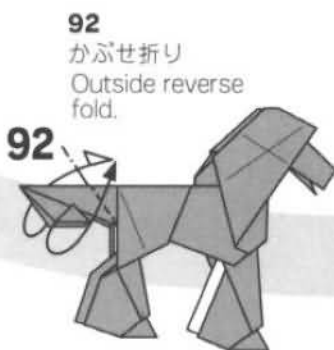

92

92
かぶせ折り
Outside reverse
fold.

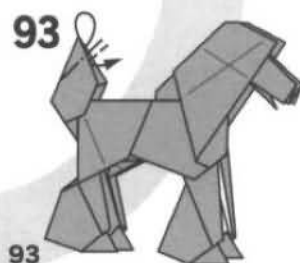

93

93
中わり折り
Inside reverse fold.

トラ

Tiger

顔を折りで作ら込むことを明確に目指したことによって、角の無限折りの幾何学的パターンを具象作品に定着させることが出来ました。折り紙における幾何学性と見立ての重要性を強く認識するきっかけとなった思い出深い作品です。

This Tiger features detailed description of a face. This is a good example of an application of geometrical pattern folds like infinite folds of angles to a descriptive model. This model let me recognize that Origami is both concrete and abstract.



Created 1985 Paper 不切正方形一枚折り: 1 piece

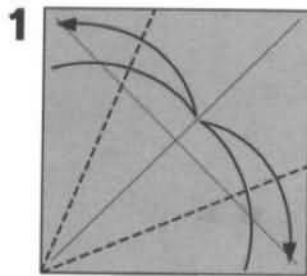

1
縁を中心に合わせて
折り筋をつける
Fold one edge to the
center diagonal.

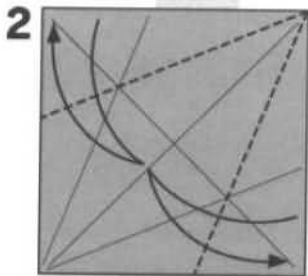

2
縁を中心に合わせて
折り筋をつける
Repeat on the
other half.

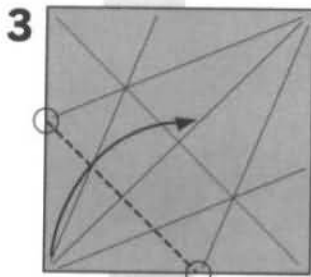

3
折り筋と縁の交点の
ところから折る
Fold up at the
intersections.

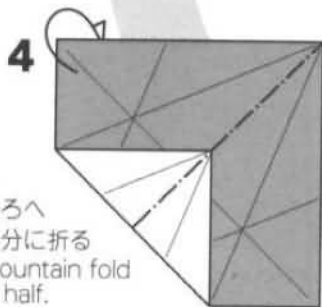

4
後ろへ
半分折る
Mountain fold
in half.



5
縁に沿って
反対側に折る
Swivel to
the right.

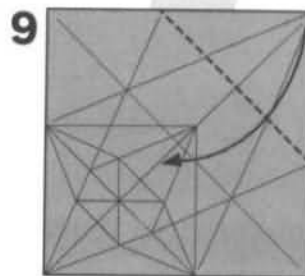

9
反対側も3~8と
同じように
折り筋をつける
Repeat 3~8 on
the other half.

8
しっかりと折り筋を
つけてからひろげる
Unfold after making
tight crease lines.

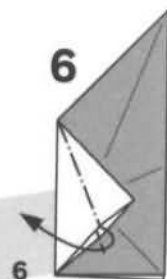
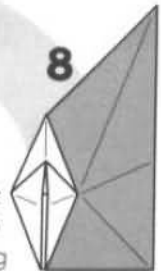

6
内側をひろげて
つぶすように折る
Open and squash.

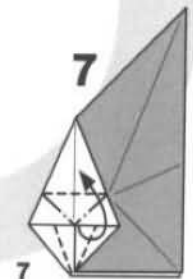

7
内側をひろげて
つぶすように折る
Swivel up and
squash.

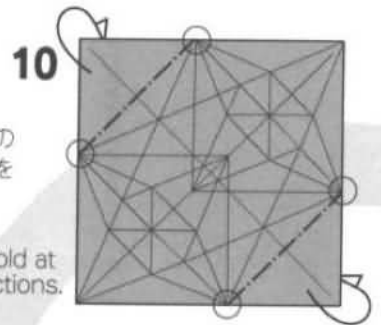

10
折り筋と縁の
交点と交点を
結ぶ線で
後ろへ折る
Mountain fold at
the intersections.

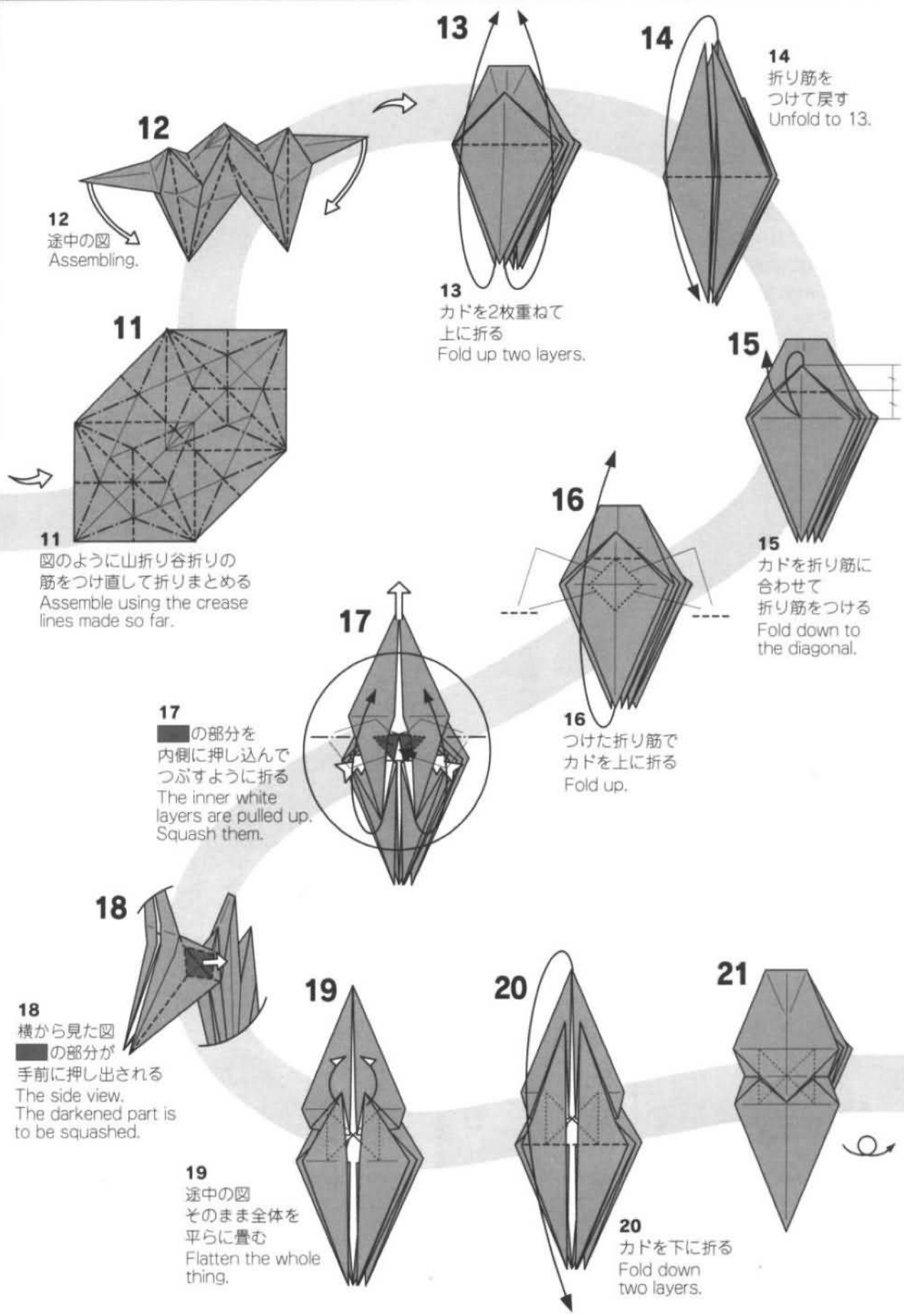

12
途中の図
Assembling.

13
カドを2枚重ねて
上に折る
Fold up two layers.

14
折り筋を
つけて戻す
Unfold to 13.

15
カドを折り筋に
合わせて
折り筋をつける
Fold down to the diagonal.

11
図のように山折り谷折りの
筋をつけ直して折りまとめる
Assemble using the crease
lines made so far.

17
■の部分
内側に押し込んで
つぶすように折る
The inner white
layers are pulled up.
Squash them.

16
つけた折り筋で
カドを上
に折る
Fold up.

18
横から見た図
■の部分が
手前に押し出される
The side view.
The darkened part is
to be squashed.

19
途中の図
そのまま全体を
平らに畳む
Flatten the whole
thing.

20
カドを下に折る
Fold down
two layers.

21

30

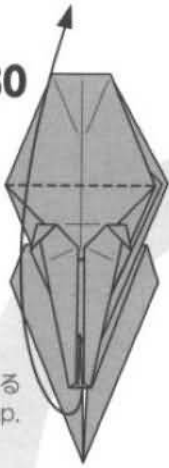

30
カドを
上に折る
Fold up.

31

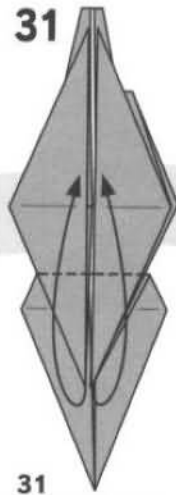

31
開くところで
カドを上折る
Swivel at the
lower joint.

32

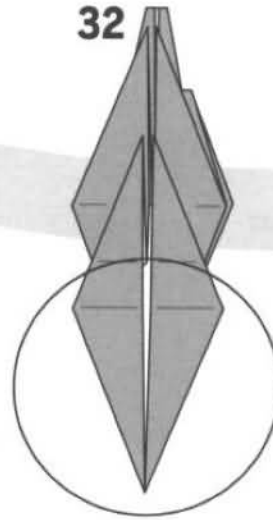

33

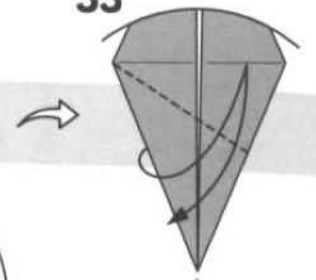

33
★
縁と折り筋を合わせて
折り筋をつける
Fold the left edge to
the diagonal. Unfold.

29

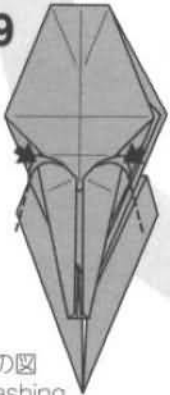

29
途中の図
Squashing.

28

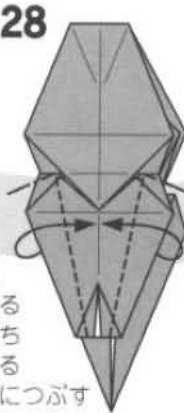

28
縁を中心に
合わせて折る
つられて持ち
上がってくる
部分を三角につぶす
Fold edges to the
vertical center line.
Squash the layers
pulled up.

27

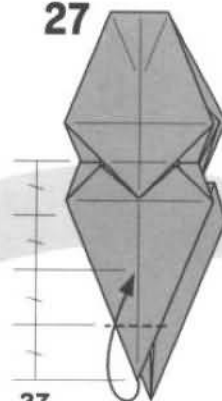

27
1/4のところ
で上に折る
Fold up at the quarter
of the length below
the middle joint.

26

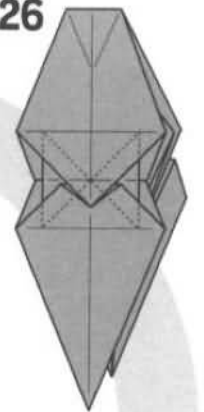

22

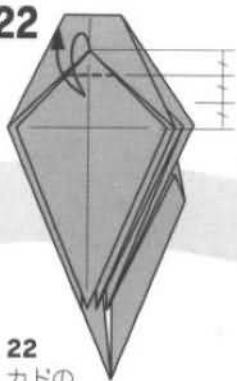

22
カドの
1/3のところ
で
折り筋をつける
Make a crease line at
the third of the length
above the diagonal.

23

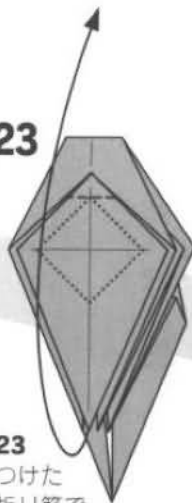

23
つけた
折り筋で
カドを上折る
Fold up.

24



24
■の部分
を
内側に押し込んで
つぶすように折る
Squash the inner
white layers as you
did in 17.

25

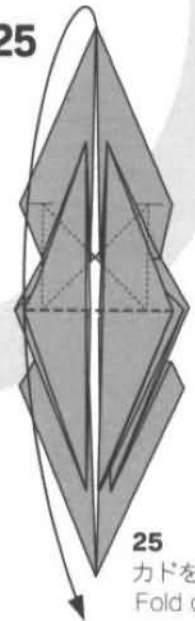

25
カドを下に折る
Fold down.

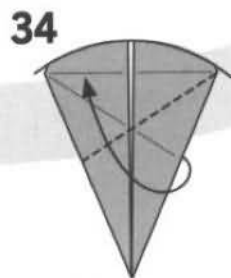

34
 縁と折り筋を
 合わせて折る
 Repeat on the
 right.

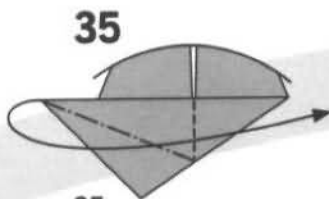

35
 カドをつまむように折る
 Rabbit ear fold.

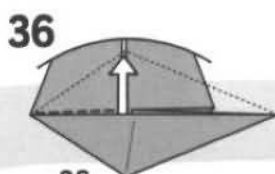

36
 内側のカドを
 引き出す
 Pull out the
 hidden layer.

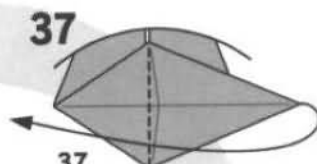

37
 カドを反対側に折る
 Swivel to the left.

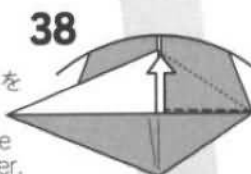

38
 内側のカドを
 引き出す
 Pull out the
 hidden layer.

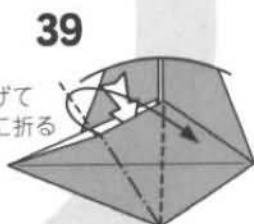

39
 内側をひろげて
 つぶすように折る
 Open and
 squash.

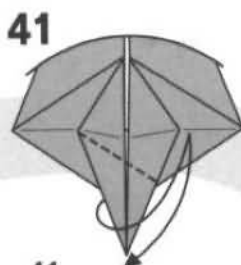

40
 内側をひろげて
 つぶすように折る
 Swivel and squash.



41
 縁と折り筋を合わせて
 折り筋をつける
 Fold the left edge
 to the diagonal.

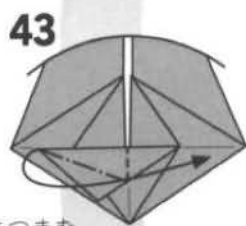

42
 縁と折り筋を
 合わせて折る
 Repeat on the
 right.

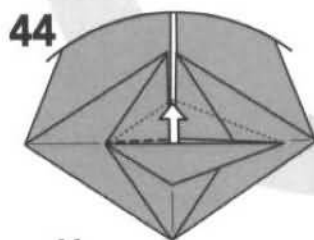

43
 カドをつまむ
 ように折る
 Rabbit ear fold.

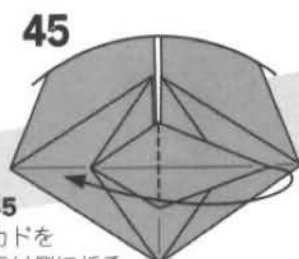

44
 内側のカドを引き出す
 Pull out the inner layer.

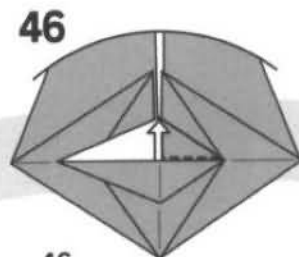

45
 カドを
 反対側に折る
 Swivel to the left.

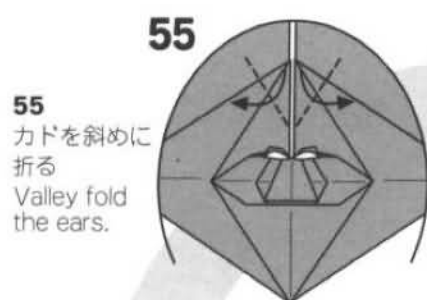

55
カドを斜めに折る
Valley fold the ears.

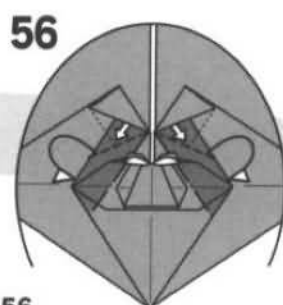

56
内側の部分を出しながら
■の部分をも後ろへ折る
Tuck the darkened parts inside.
The hidden layers of the ears
will be revealed.

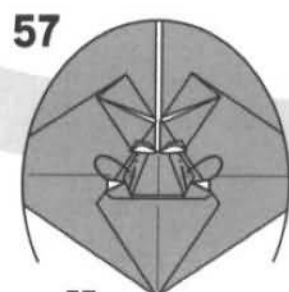

57
少し細くするように
後ろへ折る
Tuck the corners
inside.

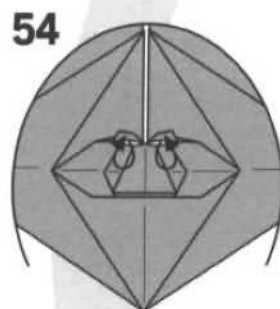

54
すき間をひろげる
Open eyes.

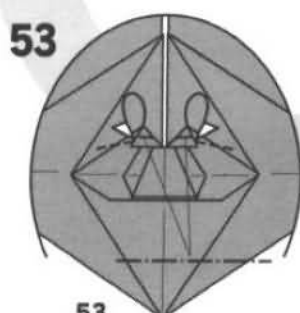

53
カドを内側に折る
Mountain fold the
top of the lid.

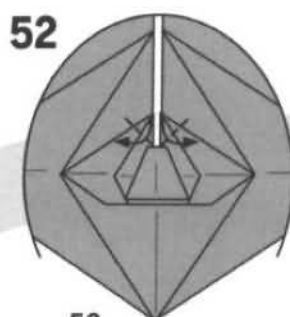

52
カドを斜めに折る
Valley folds.
This step makes
eyes.

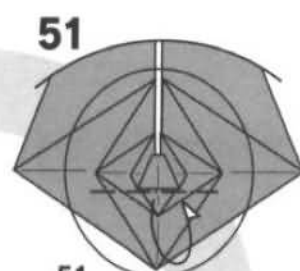

51
カドを後ろへ折る
Mountain fold the
lower corner.

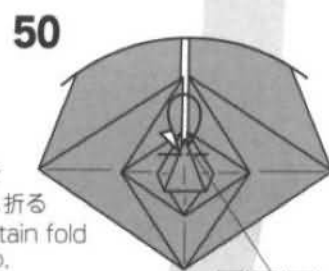

50
カドを
後ろへ折る
Mountain fold
the tip.

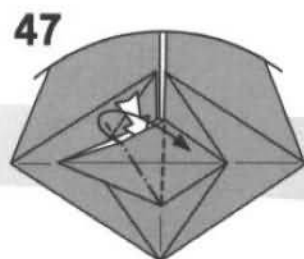

47
内側をひろげて
つぶすように折る
Open and squash.

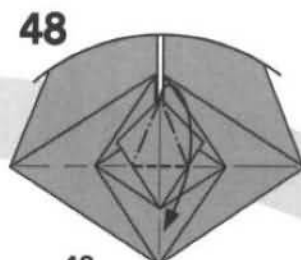

48
内側をひろげて
つぶすように折る
Swivel and squash.

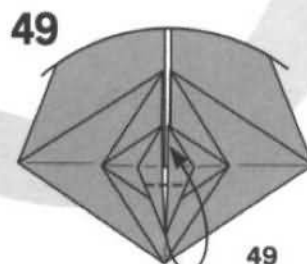

49
カドを上へ折る
Fold up.

58

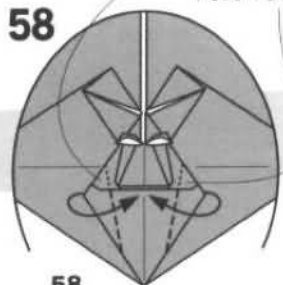

58
口になるところを
斜めに折る
Valley fold the inner layers
to form a mouth.

この部分は
内側で折る

59

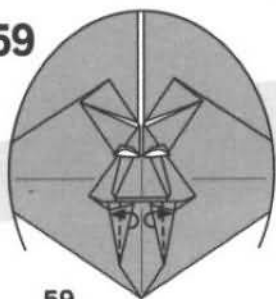

59
縁と縁を合わせて
細く折る
Fold edge to edge
and shape the
mouth.

60

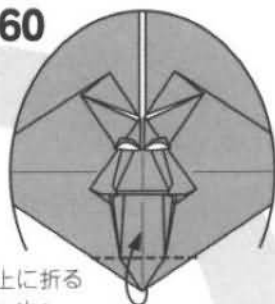

60
カドを上
に折る
Fold up the
bottom corner.

61

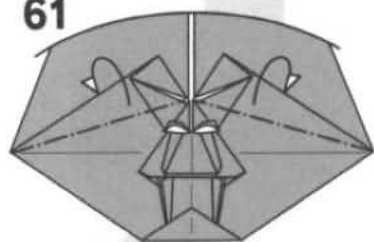

61
カドを後ろへ折る
Mountain fold
the corners.

63

内側をひろげて
つぶすように折る
Open the ears and
squash them.

63

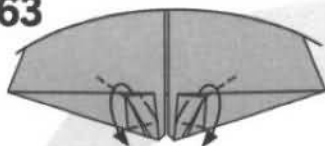

62

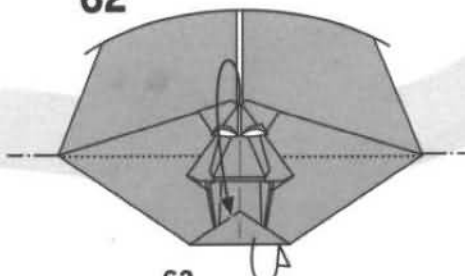

62
それぞれカドを
同時に反対側に折る
Swivel the face
backwards.

64

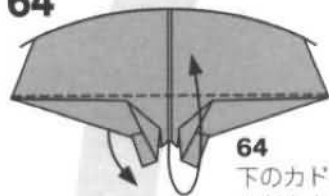

64
下のカドを出しながら
カドを上
に折る
Swivel back.

65

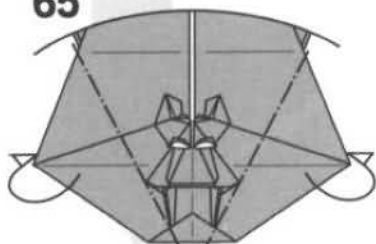

65
縁を中心に合わせて
後ろへ折る
Mountain fold the
bottom edges to
the center.

68

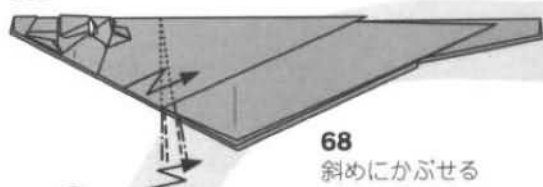

68
斜めにかぶせる
ように段折り
Pleat outside.

66

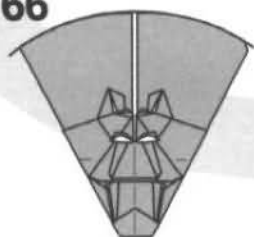

67

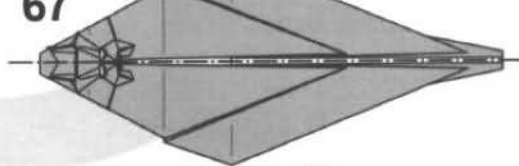

67
後ろへ半分
に折る
Mountain fold in half.

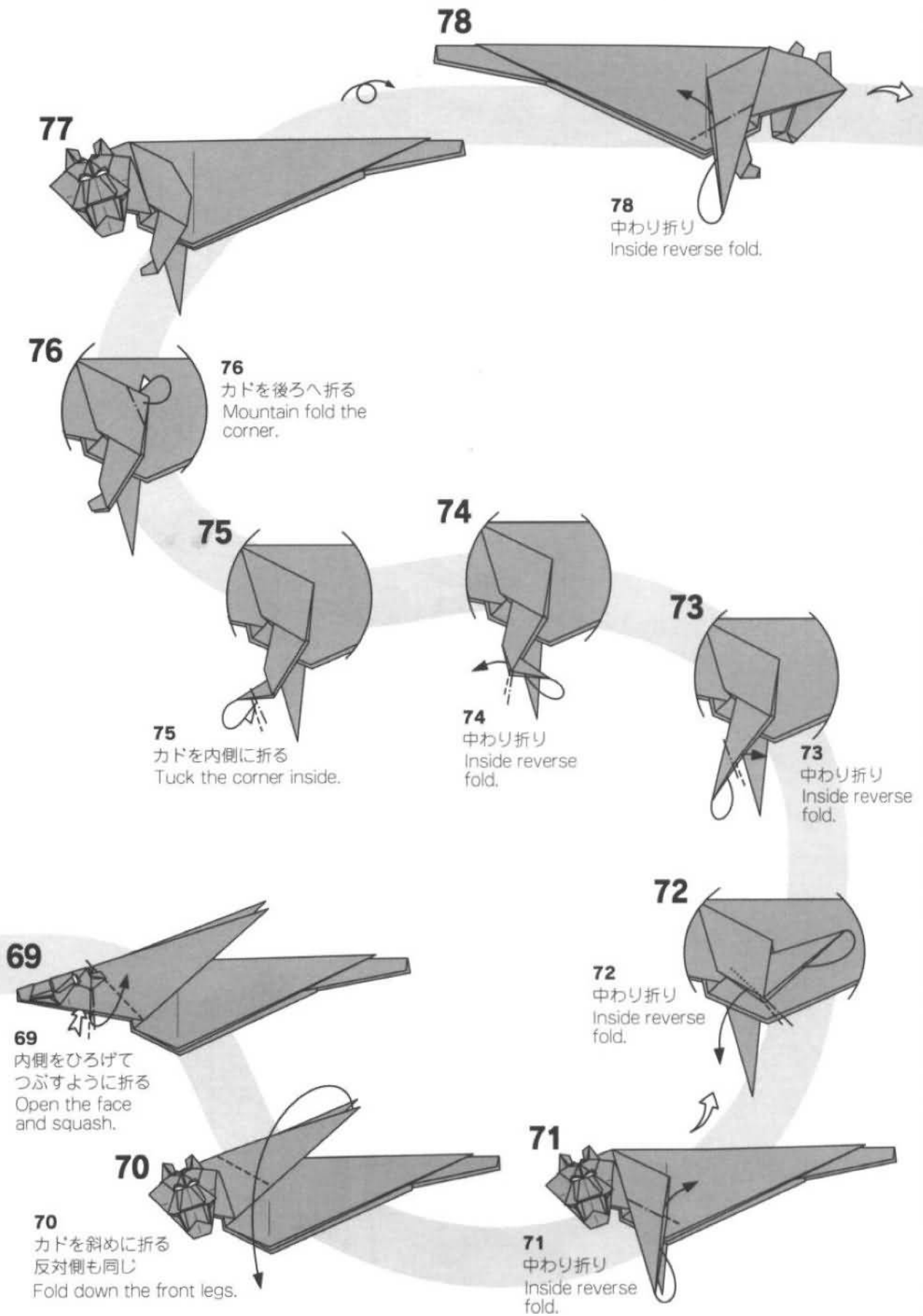

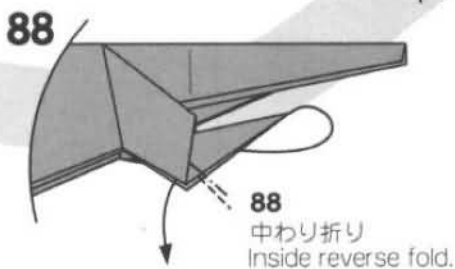
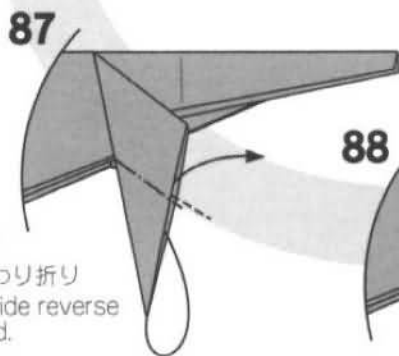
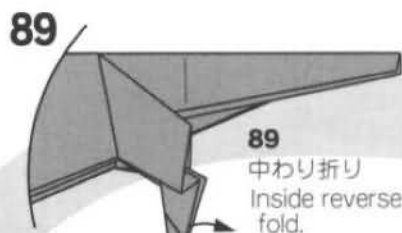
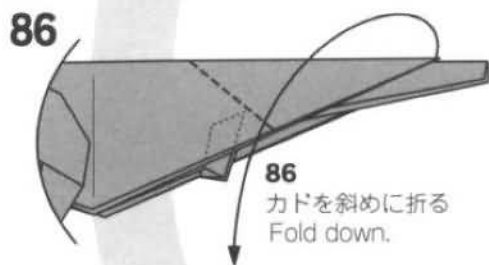
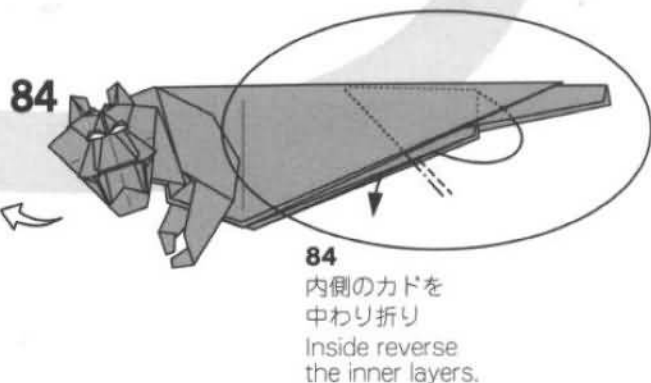
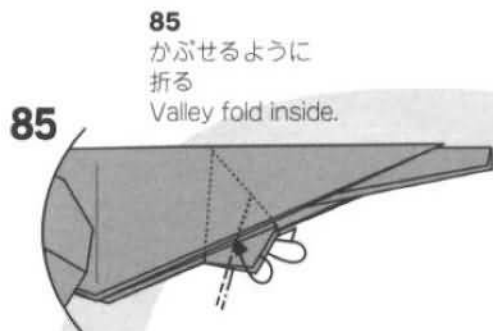
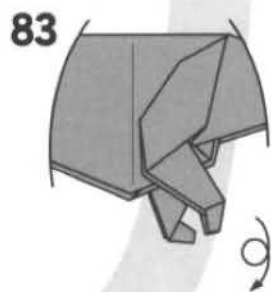
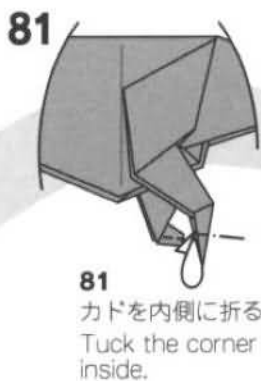
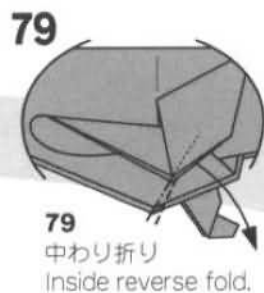

98

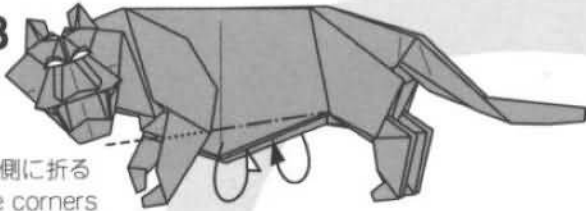

98
カドを内側に折る
Tuck the corners
on the belly inside.

97

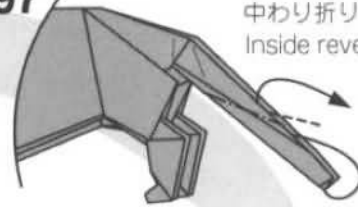

97
中わり折り
Inside reverse fold.

99

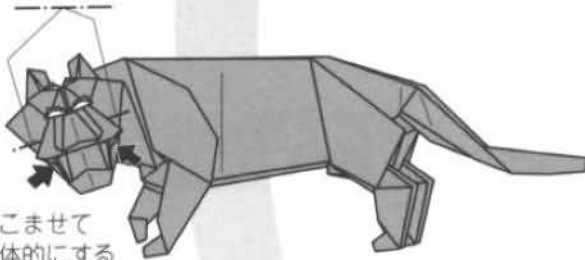

99
頬をへこませて
顔を立体的にする
Shape the cheek
and the face will
be three-dimensional.

96

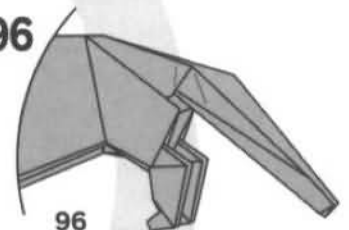

96
反対側も同じ
Repeat on the back.

100

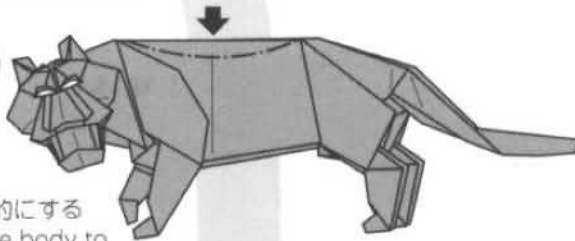

100
体を立体的にする
Shape the body to
make it three-dimensional.

95

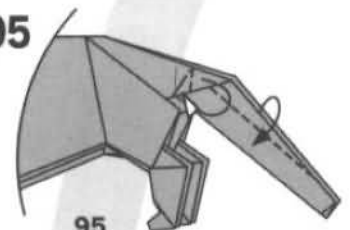

95
内側に引き寄せて
カドを細くする
Make the tail thin by
an inside reverse fold.

101

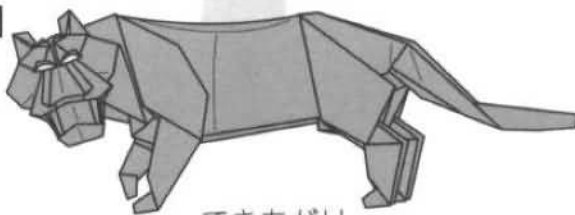

できあがり
Model Completed

94

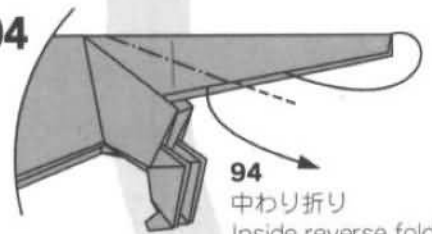

94
中わり折り
Inside reverse fold.

93

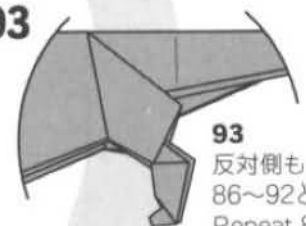

93
反対側も
86~92と同じ
Repeat 86~92
on the other leg.

90

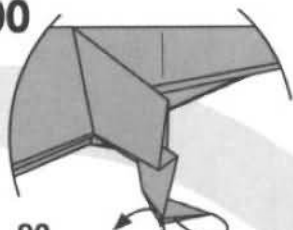

90
中わり折り
Inside reverse
fold.

91



91
カドを
内側に折る
Tuck the
corner inside.

92

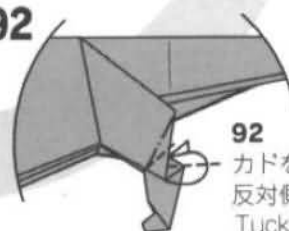

92
カドを内側に折る
反対側も同じ
Tuck the corner inside.
Repeat on the other side.

馬

Horse

体は厚くなりますので背中を割らないように気をつけて折ってください。コツをつかめば、体の厚みがむしろ重量感を与えてくれます。頭部から鬃たてがみにかけての表現は、ペガサスに引き継がれています。

Carefully form the back, as there are thick layers so that it may crack. The thickness, when carefully folded, can give this model concreteness. The head and the mane are formed in the same way as the head and the mane of Pegasus are.



Created 1989 Paper 不切正方一枚折り: 1 piece

P. 8 [鶴の基本形] から始める
Start with [Bird Base] (P. 8)

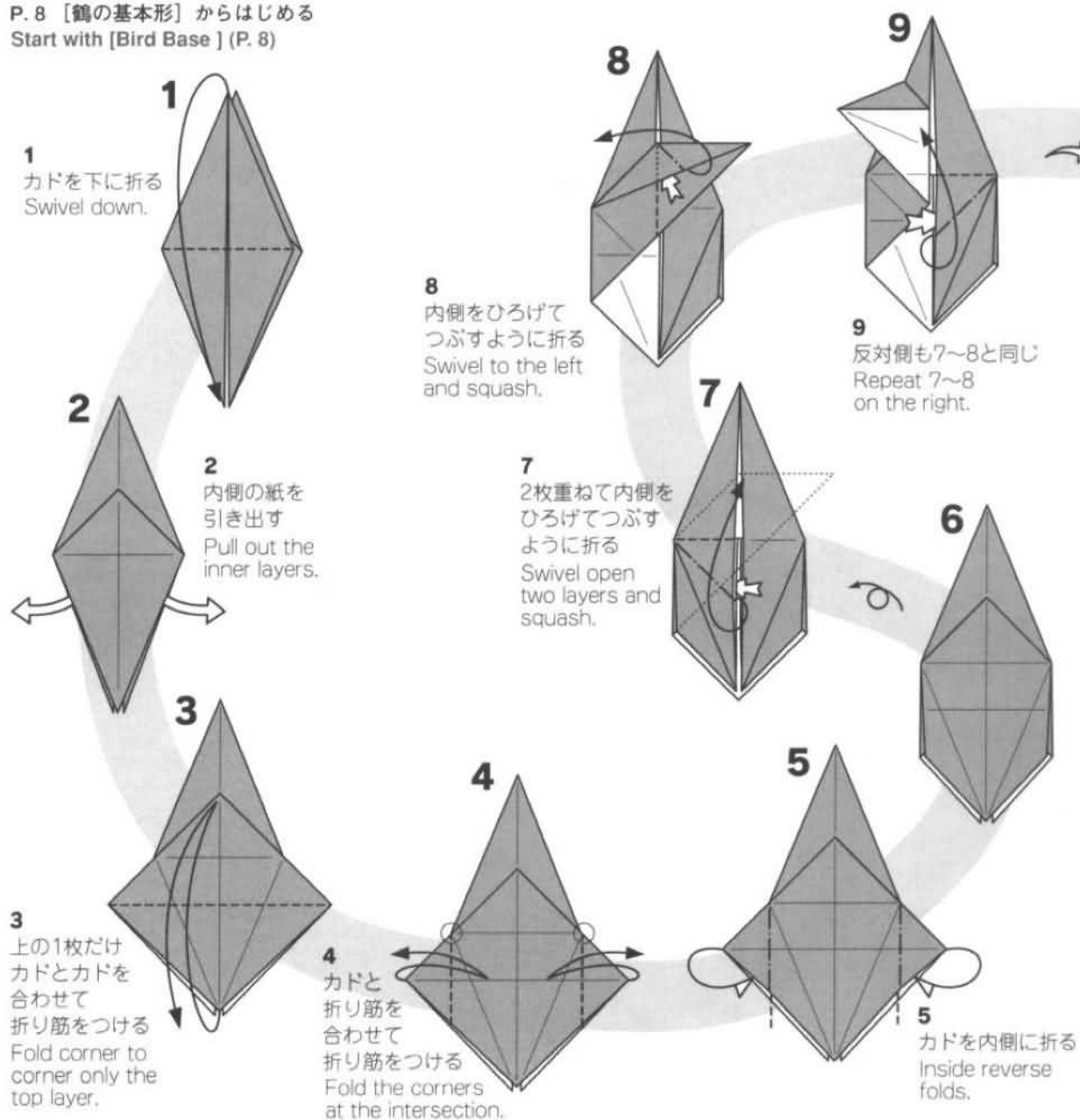

11
 縁のところで
 折り筋をつける
 Precrease along
 the edges.

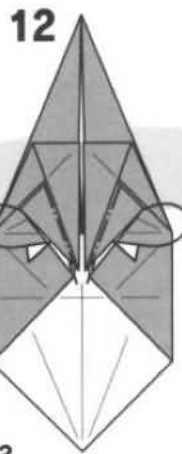
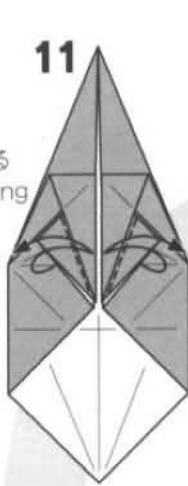

12
 カドを内側に折る
 Inside reverse folds.

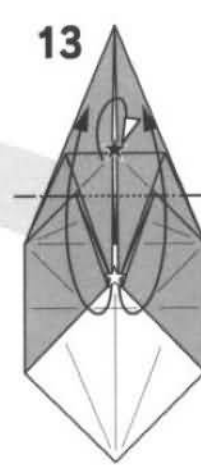

13
 ★の部分をも後ろへ
 折りながら
 ☆のカドを上へ折る
 Swivel up the corners
 with ☆ while tucking
 the top edges ★
 inside.

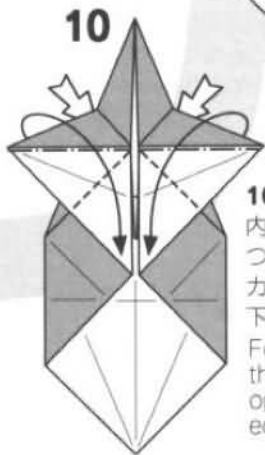

10
 内側をひろげて
 つぶすようにして
 カドをつまんで
 下に折る
 Fold corners down to
 the center while
 opening the top
 edges.

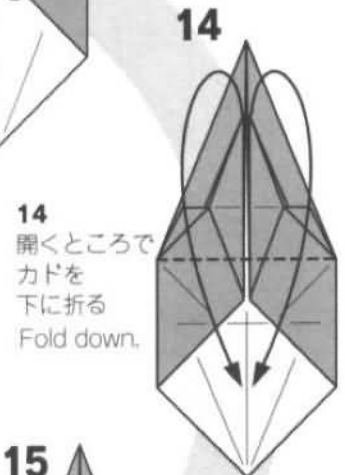

14
 開くところで
 カドを
 下に折る
 Fold down.

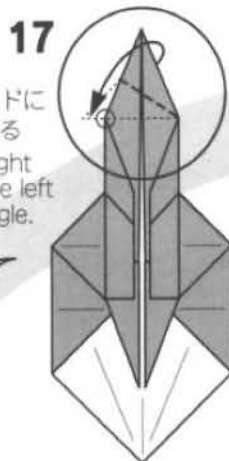

17
 縁を○のカドに
 合わせて折る
 Fold the right
 edge to the left
 obtuse angle.

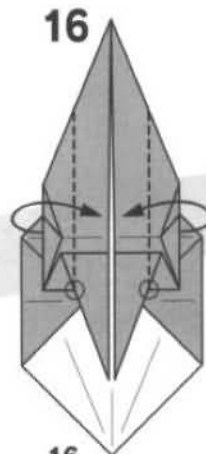

16
 縁の交点の
 ところで折る
 Fold at the
 intersections
 of the edges.

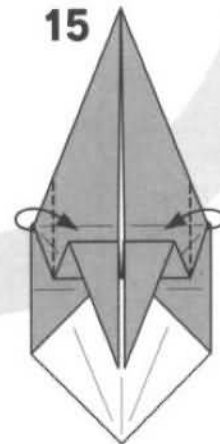

15
 カドを折り筋に
 合わせて折る
 Fold corners so
 the edges align
 with the inner
 edges.

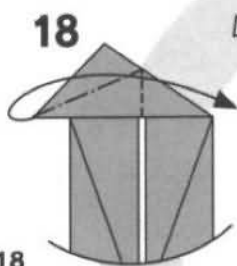

18
 カドをつまむ
 ように折る
 A rabbit-ear
 fold.



19
 内側の紙を
 引き出す
 Pull out the
 inner layer.

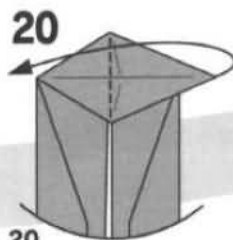

20
 カドを反対側に折る
 Swivel to the left.

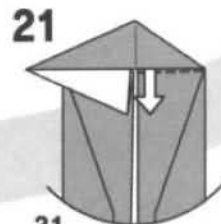

21
 内側の紙を
 引き出す
 Pull out the
 inner layer.



22
 縁を中心に
 合わせて
 折り筋をつける
 Fold the edge to
 the center.

31
内側をひろげて
ついている折り筋で
反対側に折る
Open along the
precrease line.

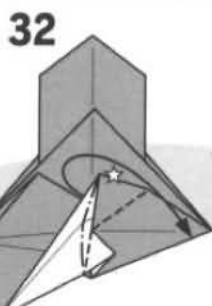
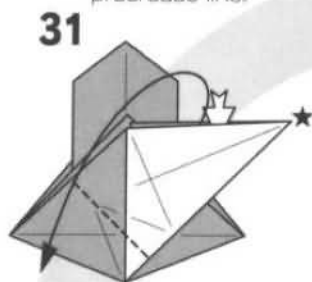

32
★
ついている折り筋で
つぶすように折る
Do the same on
the right.

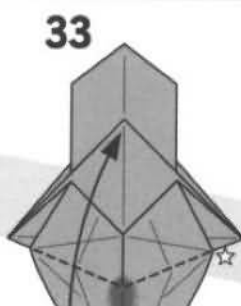

33
★
カドとカドを
合わせて折る
Fold corner to
corner.

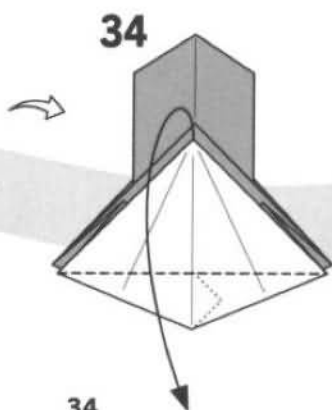

34
カドとカドを結ぶ線
で折る
Fold along the horizontal
intersection.

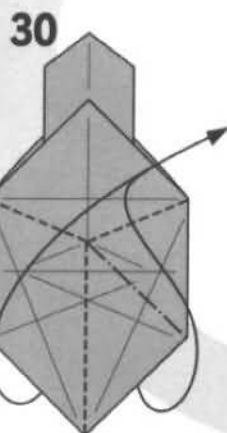

30
つけた折り筋を
使って折りたたむ
Fold as shown.
A kind of rabbit-ear
fold.

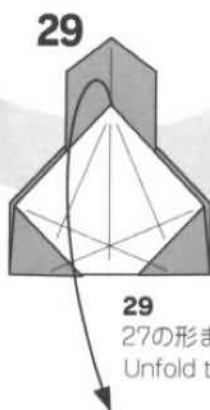

29
27の形まで戻す
Unfold to 27.

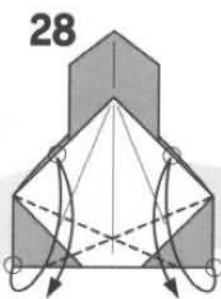

28
カドと線に合わせて
折り筋をつける
Fold the corners to
the top edges.

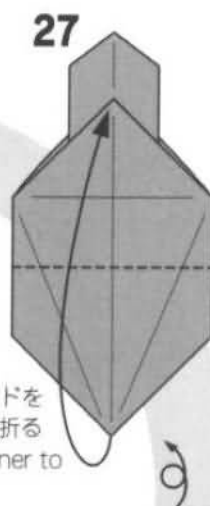

27
カドとカドを
合わせて折る
Fold corner to
corner.

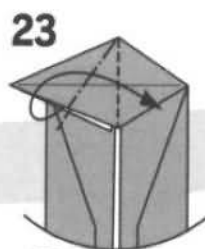

23
内側をひろげて
つぶすように折る
Open and squash.

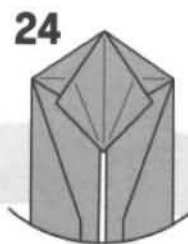

25
線を内側に
折りながら
カドを上
に折る
Swivel up while narrowing
the edges (a kind of
inside-reverse fold).

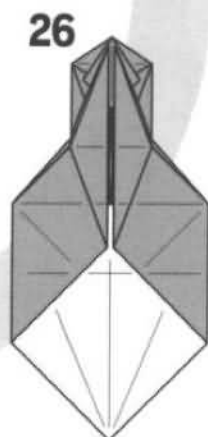
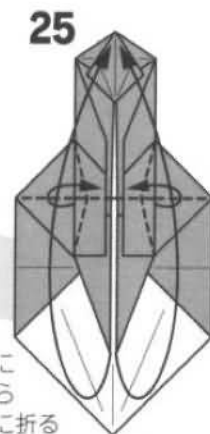

26

35

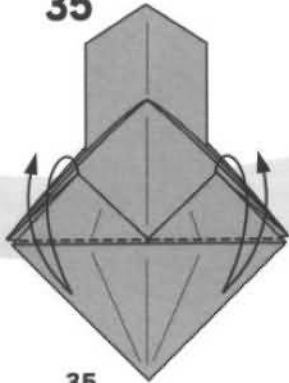

35
縁のところで
折り筋をつける
Precrease along
the edge.

36

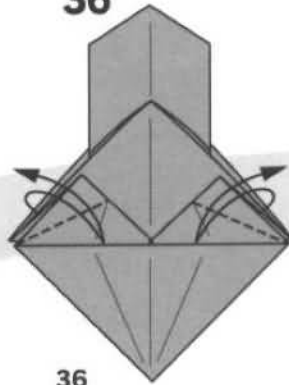

36
縁と縁を合わせて
折り筋をつける
Fold the top edges
to the diagonal edge.

37

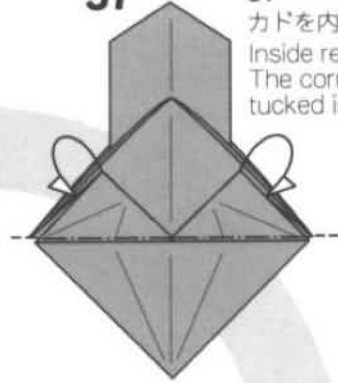

37
カドを内側に折る
Inside reverse folds.
The corners are
tucked in.

38

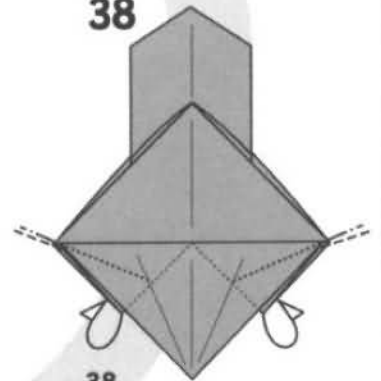

38
36でつけた折り筋で
カドを内側に折る
Inside reverse folds
along the precrease
lines of 36.

40

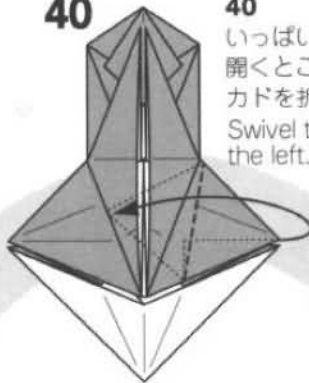

40
いっぱい
開くところで
カドを折る
Swivel to
the left.

39

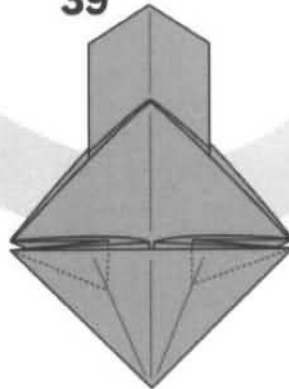

41

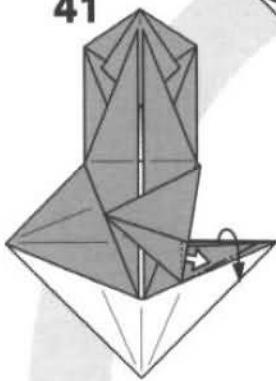

41
内側の紙を
引き出して
ずらしてつぶす
ように折る
Pull out the layer
tucked in and
squash.

42

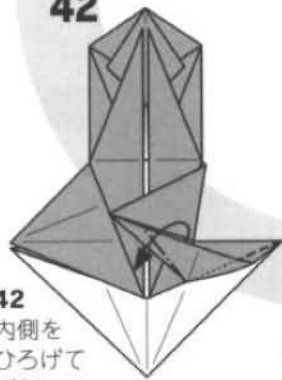

42
内側を
ひろげて
ずらして
つぶすように折る
Open and squash.

43

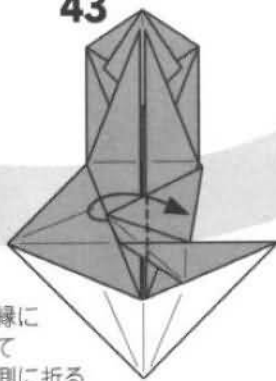

43
下の縁
沿って
反対側に折る
Swivel to the right.

44

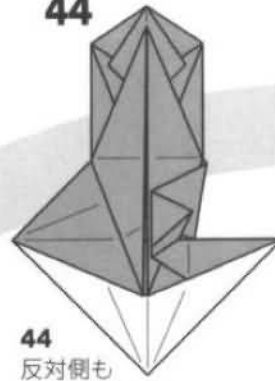

44
反対側も
40~43と同じ
Repeat 40~43
on the left.

45

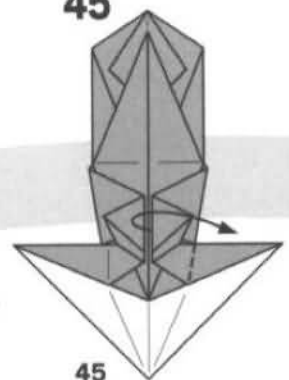

45
片側のカドを
反対側に折る
Swivel to the right.

55

かぶせるように
斜めに段折り
Pleat outside.

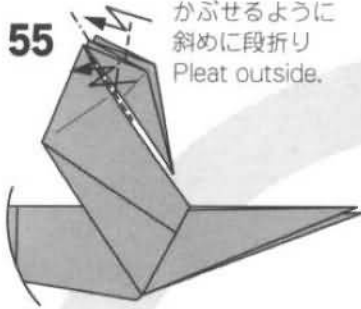

56

重なり部分を
内側から引き出す
反対側も同じ
Separate and
show the inner
overlapping layers.

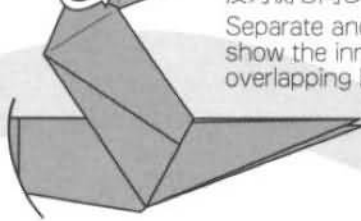

57

■の部分
内側に
折り込むように
斜めに段折り
Pleat inside the
darkened part..



54

しっかりと折り筋を
つけてから戻す
Unfold to 52.

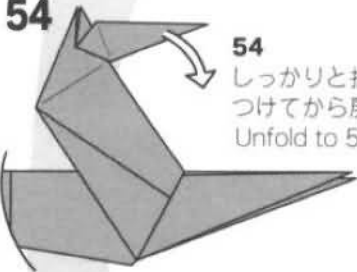

52

2枚いっしょに
縁のところで折る
Fold the two layers
to the left.

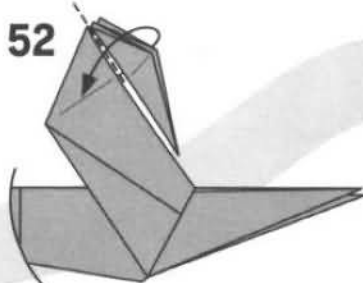

51

内側をひろげて
つぶすように折る
反対側も同じ
Open up and squash.
Repeat on the back.

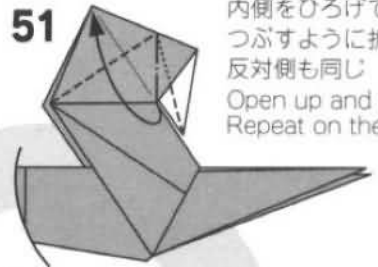

53

2枚いっしょに
斜めに折る
Fold up the
two layers.

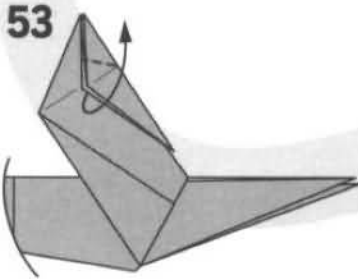

50

それぞれカドを
反対側に折る
Swivel to the
right.
Repeat on the back.

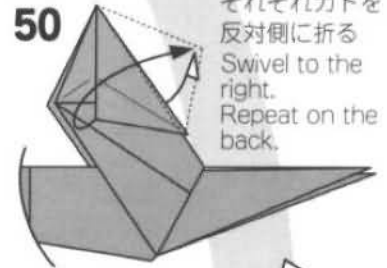

46

カドをすき間に差し込む
Tuck the corners inside.

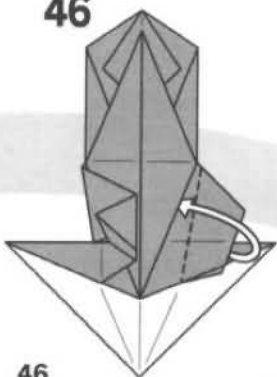

47

カドを反対側の
すき間に差し込み
ながら半分に折る
Fold in half while
tucking the left
corners inside the
pocket in 46.

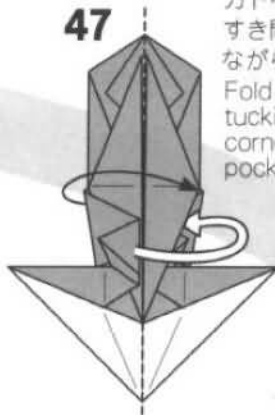

49

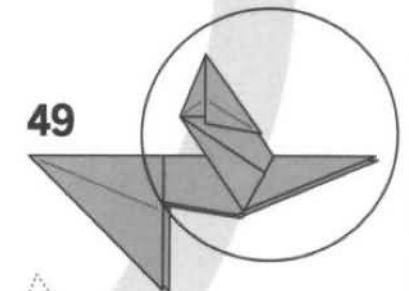

48

かぶせ折り
Outside reverse fold.

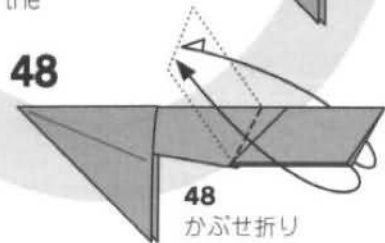

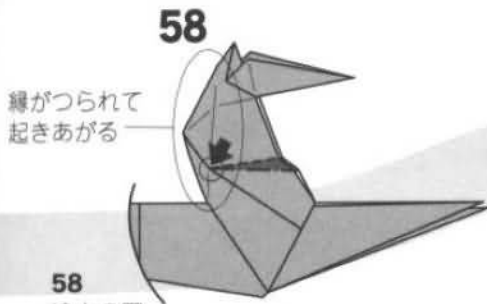

線がつられて
起きあがる

58
途中の図
黒矢印の部分
押し込んで折る
Push the arrowed
corner inside.

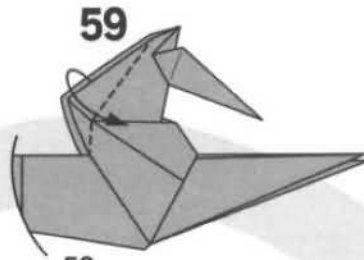

59
起きあがった線
つぶすように折る
反対側も同じ
Squash the layers
pulled up by 58.

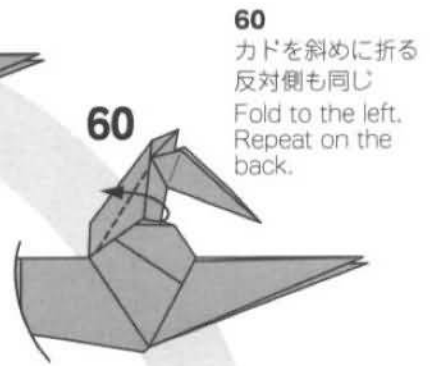

60
カドを斜めに折る
反対側も同じ
Fold to the left.
Repeat on the back.

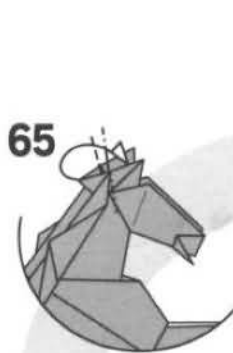

65
真ん中のカドを
内側に折る
Inside reverse
fold again.



64
真ん中のカドを
中わり折り
Inside reverse fold
the middle layer.

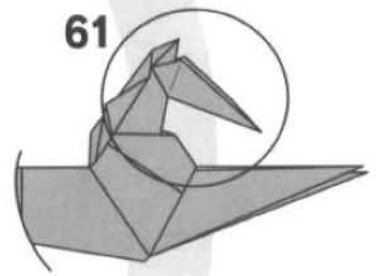

62
かぶせ折り
Outside reverse
fold.

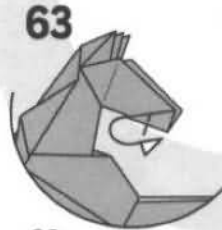

63
かぶせ折り
Outside reverse
fold.

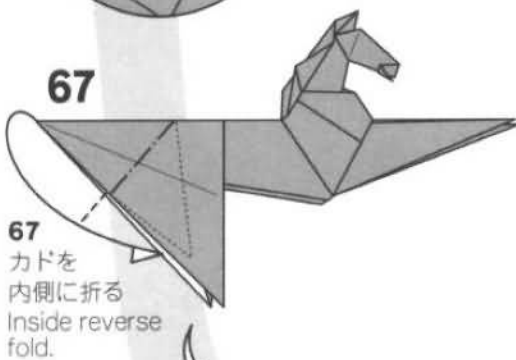
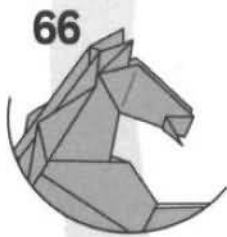

67
カドを
内側に折る
Inside reverse
fold.



68
カドを
内側に折る
反対側も同じ
Inside reverse fold.
Repeat on the back

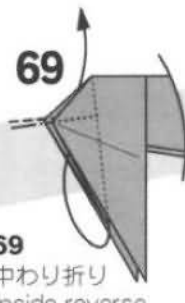

69
中わり折り
Inside reverse
fold.

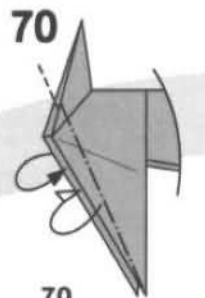

70
線を内側へ折る
Narrow the rear
legs.

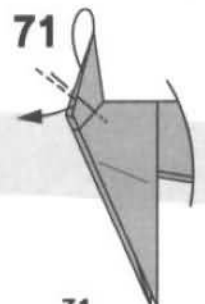

71
中わり折り
Inside reverse
fold.

81
カドを内側に折る
Inside reverse fold
the tip of the toe.

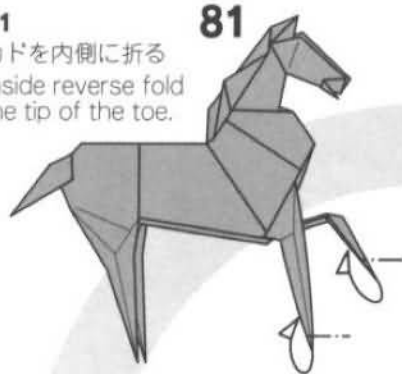

82
■の部分をつぶして平らにする
Squash the darkened part.

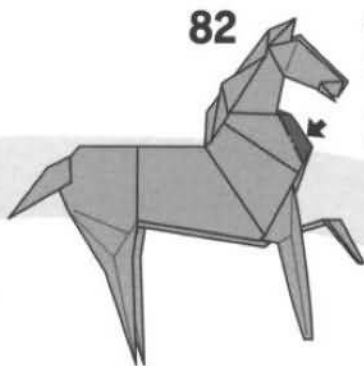

できあがり
Model Completed

80
つまんで細くする
ように折る
反対側も同じ
Rabbit-ear folds

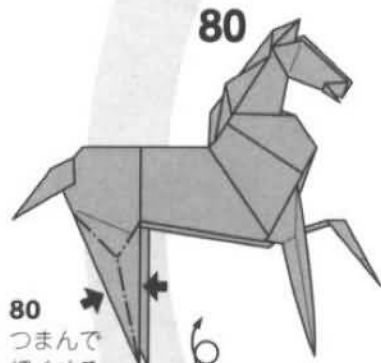

78
カドをつまんで
かるく引っ張って
立体的にする
Pinch the corner
and shape it into
a 3-D form.

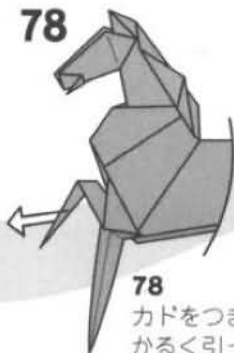

77
カドを後ろへ折る
A mountain fold.

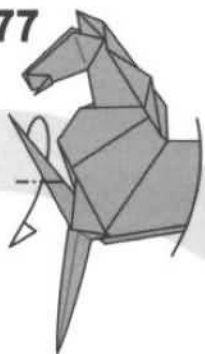

76
カドをつまんで
後ろへ上に折る
A rabbit-eat fold
and fold up.

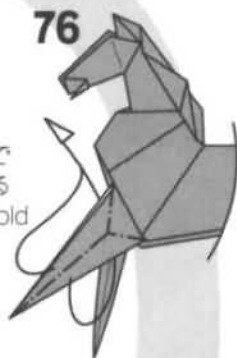

72
かぶせ折り
Outside
reverse fold.



73
斜めに段折り
反対側も同じ
Pleat inside.
Repeat on
the back.

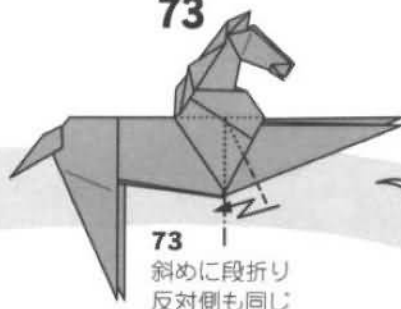

74
カドをつまんで
細くするように
しながら下に折る
A rabbit-ear fold.

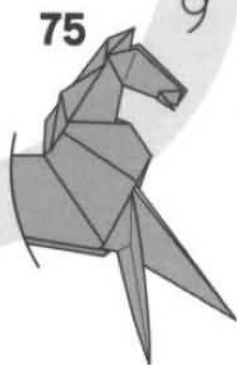
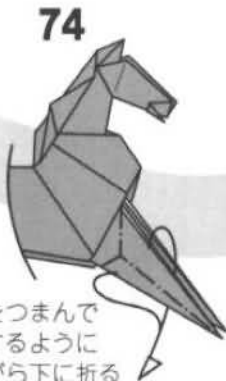

縞のあるトラ

Tiger (with Stripes)

インサイドアウトにより縞を表現したトラですが、作品としてのまとまりを与えているのは、あまり手を加えずに仕上がった顔のようです。図20の段折りは、図に示されている通り、脚の幅よりやや広めのところで山線を取ります。

Despite an inside-out expression of stripes, the face integrates the whole model. The pleat in 20 must be wider than the width of the part squashed in 14.



Created 1994 Paper 不切正方一枚折り: 1 piece

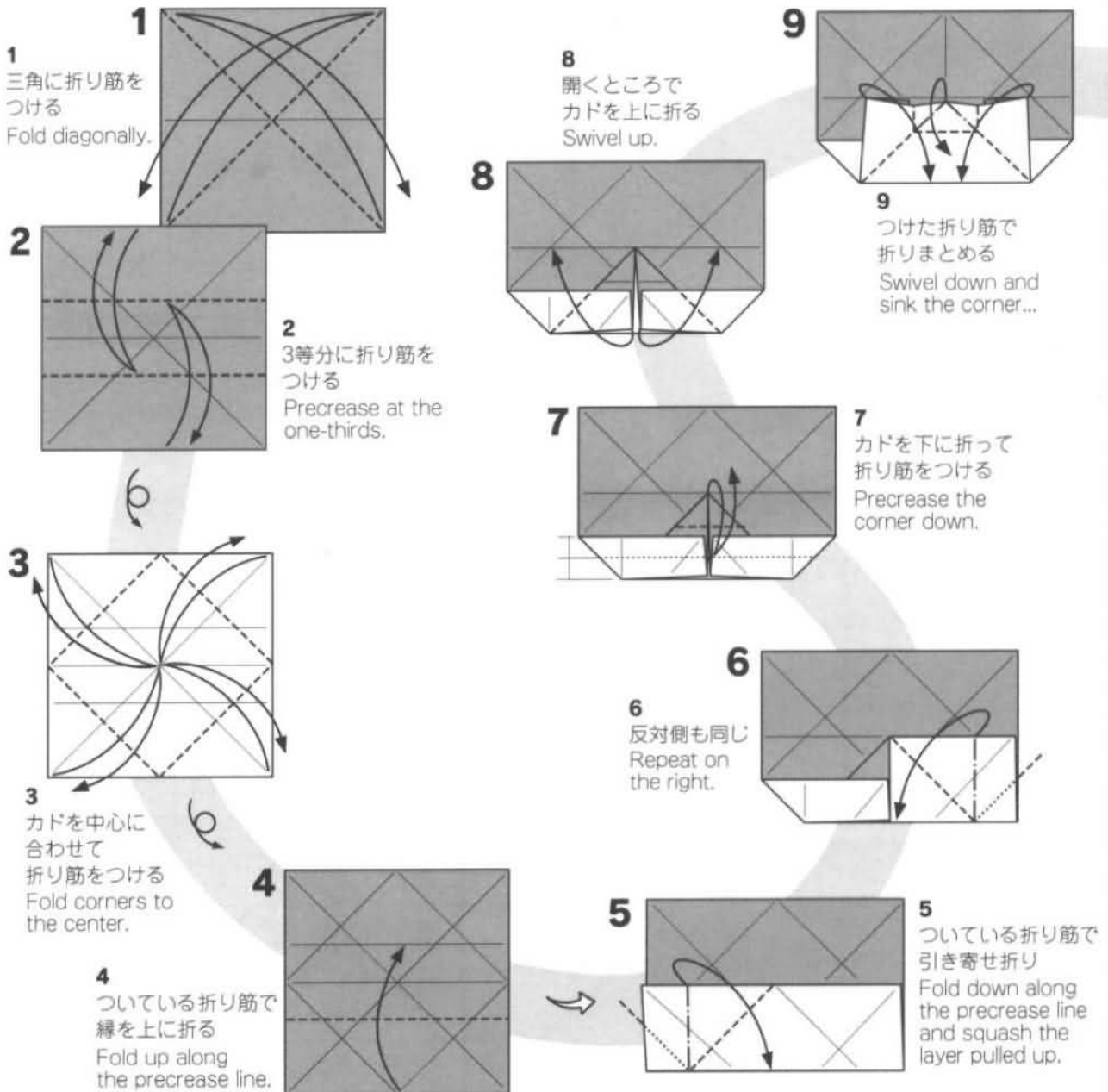

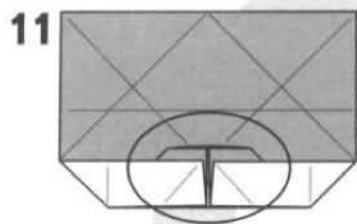

11

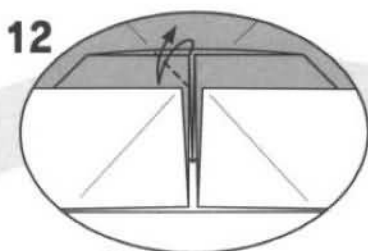

12

12
縁と縁を合わせて
折り筋をつける
Fold edge to edge.

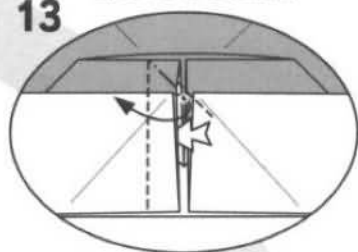

13

13
内側をひろげて
つぶすように折る
Open and squash.

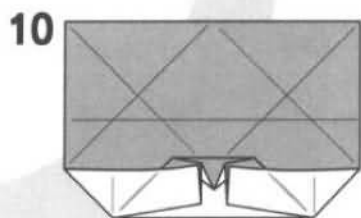

10

10
途中の図
as shown.

14
右側も12~
13と同じ
Repeat on
the right.

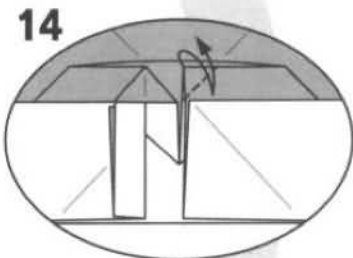

14

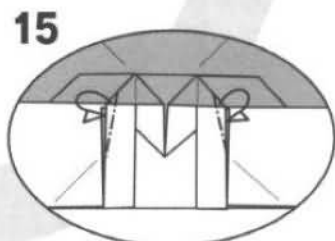

15

15
カドを後ろへ折る
Mountain fold the
corners.

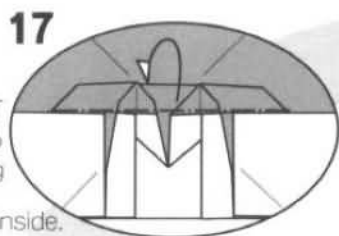

17

17
縁に沿って
内側に折る
Fold along
the edge
and tuck inside.

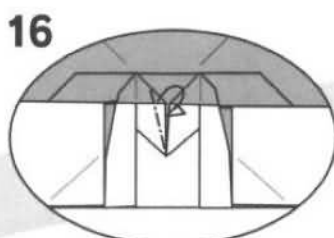

16

16
カドを後ろへ折る
Mountain fold the
corners.

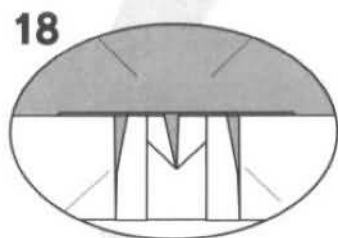

18

21
折り筋をつけてから
20の形まで戻す
Unfold to 20.

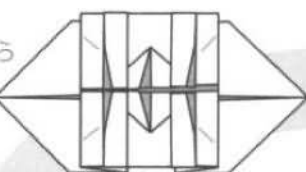

21

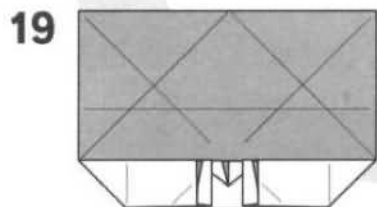

19

19
反対側も4~17と同じ
Repeat 4~17 on the top.

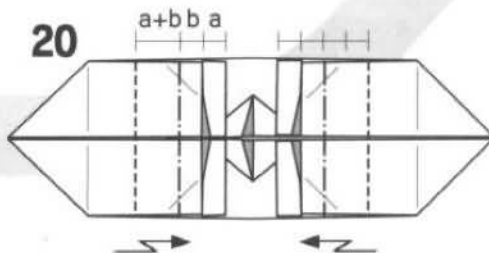

20

20
段折り
bの幅をaの幅より
わずかに多めに取る
Fold pleats.
Note that b is
slightly wider
than a.

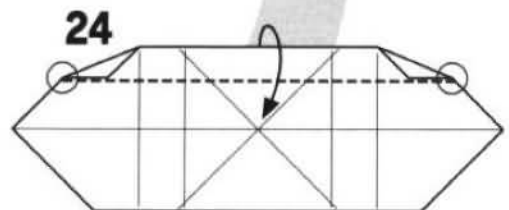
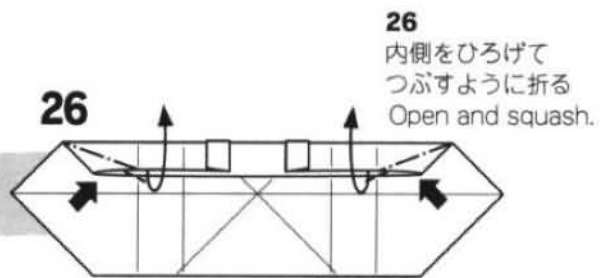
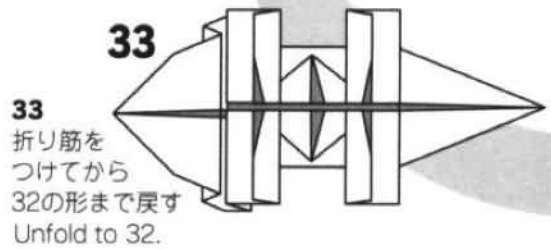
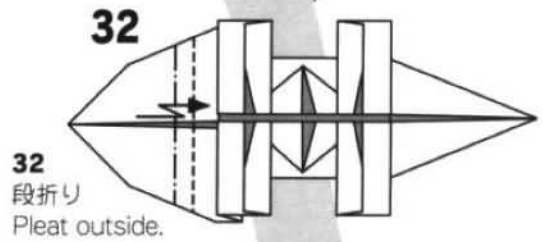
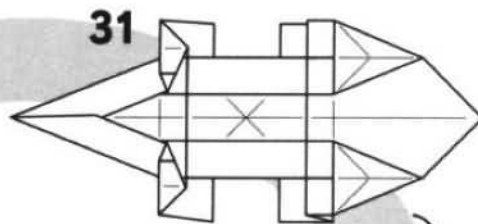
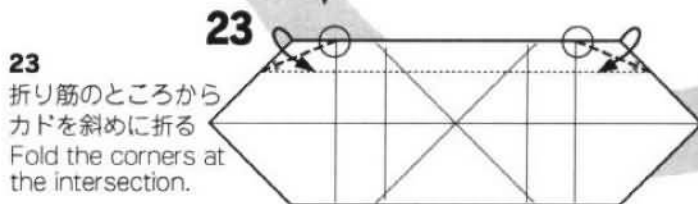
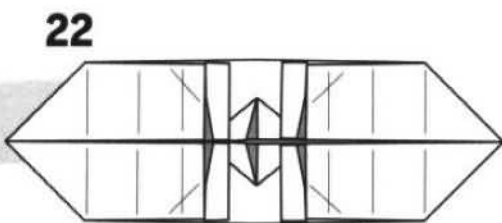
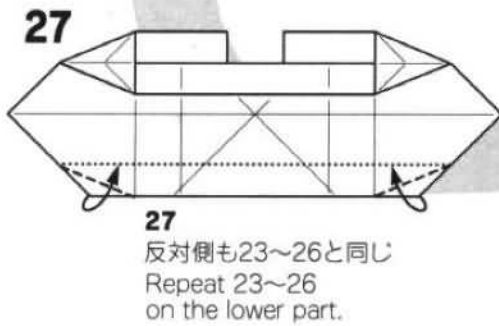
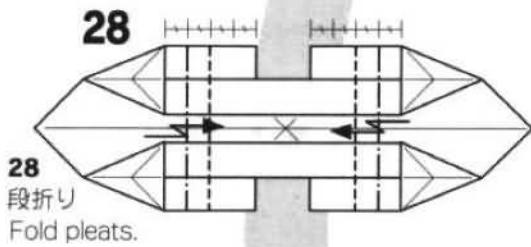
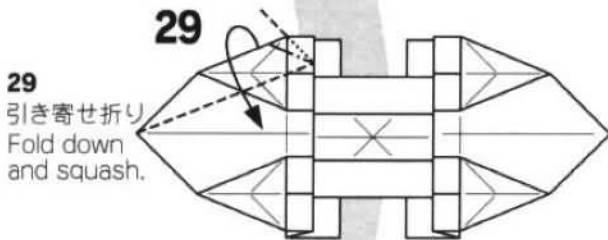
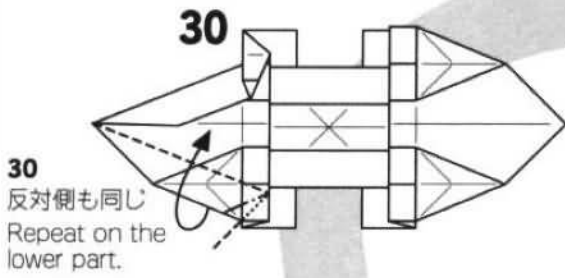

35
内側をひろげながら
ついている折り筋で
折りまとめる
Refold the pleats
while opening and
squashing the middle
portion as shown...

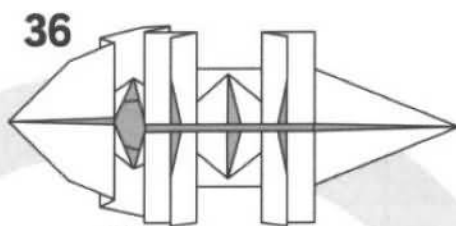
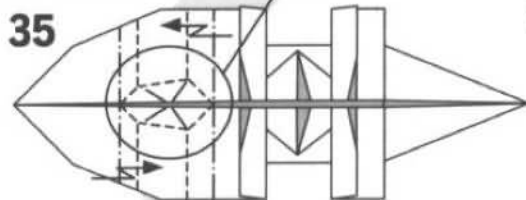

36
途中の図
like this.

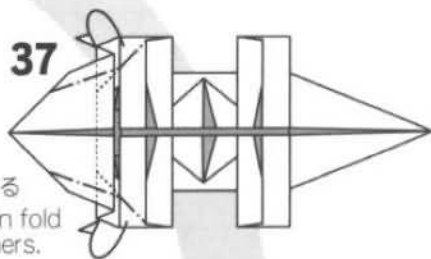

37
カドを
後ろへ折る
Mountain fold
the corners.

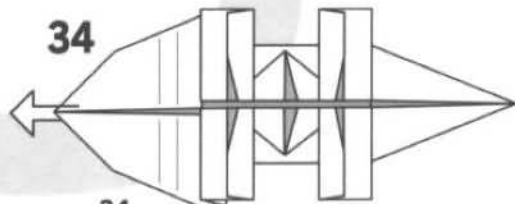

34
段折りの部分を
ひろげる
Open the pleats.

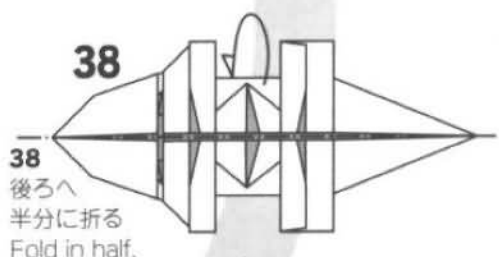

38
後ろへ
半分に折る
Fold in half.

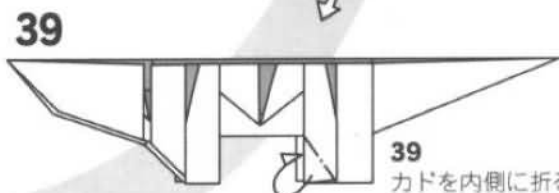

39
カドを内側に折る
反対側も同じ
Mountain fold the
rear feet.

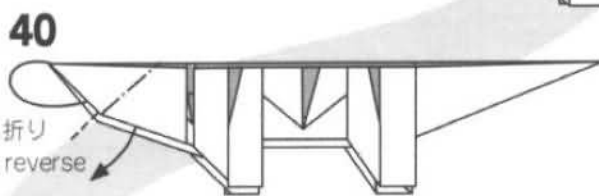

40
中わり折り
Inside reverse
fold.

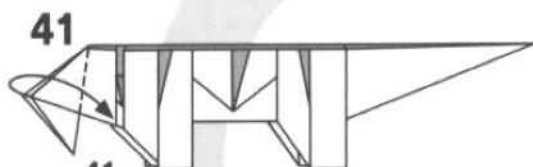

41
カドを開くところで折る
Swivel to the right.

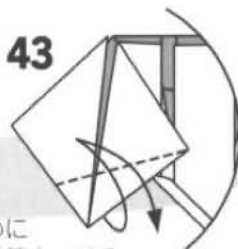
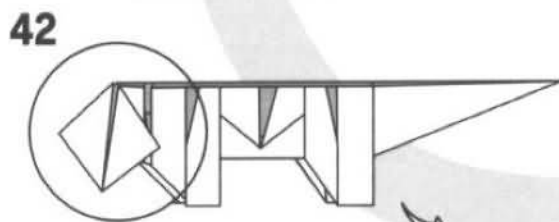

43
斜めに
折り筋をつける
Precrease as shown.

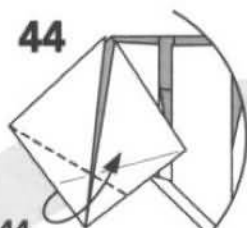

44
カドを斜めに折る
Repeat on the left.

54

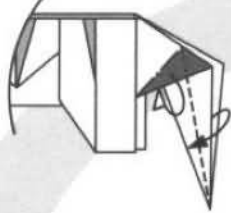

54
 ■の部分の内側に
 折り込みながら
 つけた折り筋で縁と
 縁を合わせて折る
 Tuck the darkened
 part inside and
 narrow the tail
 again.

55

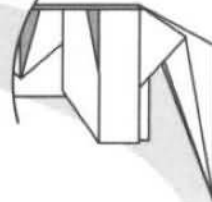

55
 反対側も同じ
 Repeat on the
 back.

53

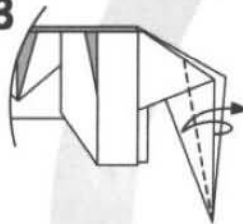

53
 縁と縁を合わせて
 折り筋をつける
 Narrow the tail.
 Unfold.

56

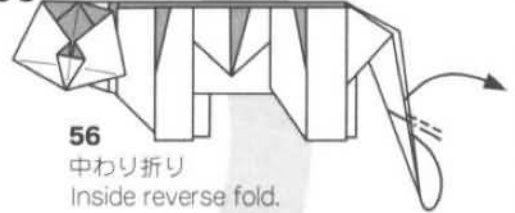

56
 中わり折り
 Inside reverse fold.

52

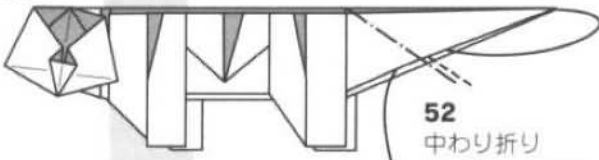

52
 中わり折り
 Inside reverse fold.

57

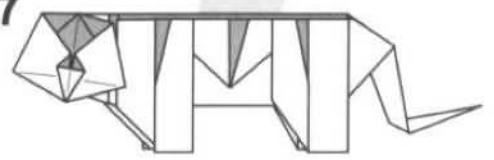

できあがり
 Model Completed

51

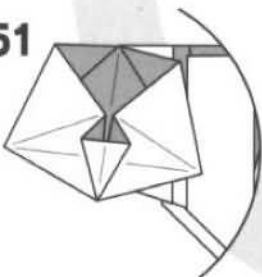

50



50
 内側をひろげて
 つぶすように折る
 Open and squash.

49



49
 カドを
 反対側に折る
 Swivel to the left.

48

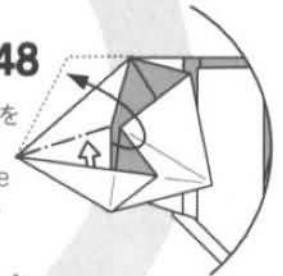

48
 内側のカドを
 引き出す
 Pull out the
 inner layer.

45

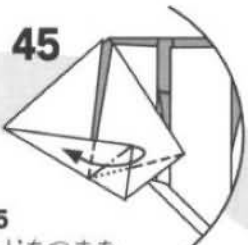

45
 カドをつまむ
 ように折る
 Form a rabbit-ear.

46



46
 内側のカドを引き出す
 Pull out the inner layer.

47



47
 カドを
 反対側に折る
 Swivel to the right.

シンプルライオン

A Simple Lion

折り紙表現を支える“見立て”の持つ簡明さと危うさを意識して創作したものです。ライオンと言われればライオン。チャウチャウと言われればそうとも言え、なんだかかわからんと言ってしまうえばそれだけのものです。

This model was created to show how the initial diagnosis of the target can be simple and fragile. What does it look like to you?

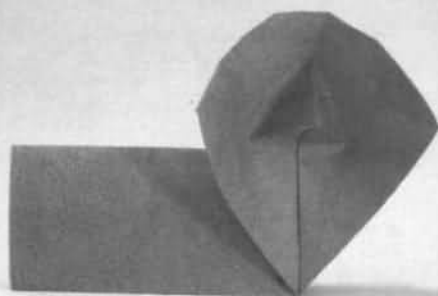

Created 1983 Paper 不切正方一枚折り: 1 piece

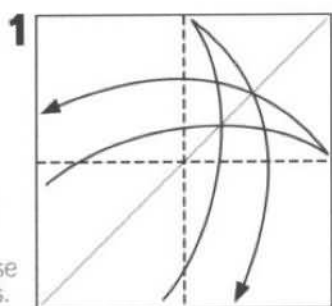

1
半分に
折り筋を
つける
Precrease
in halves.

6

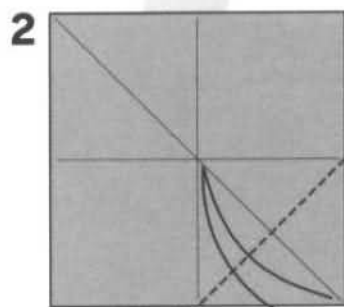

2
カドを
中心に合わせて
折り筋をつける
Fold the bottom right
corner to the center.

6

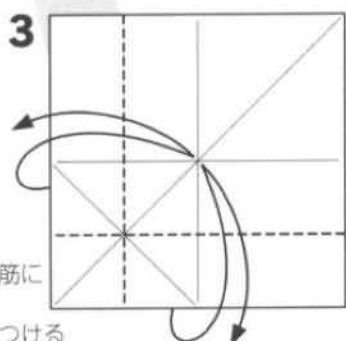

3
縁を折り筋に
合わせて
折り筋をつける
Fold at quarters
of length.

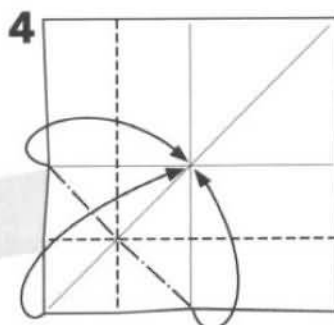

4
つけた折り筋で折りたたむ
Form the preliminary base at
the bottom left.

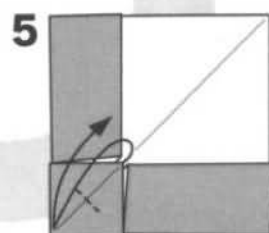

5
カドとカドを合わせて
印をつける
Mark the middle point.

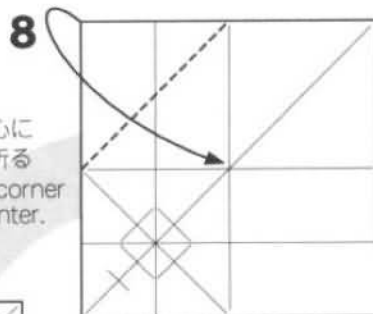

8
カドを中心
に合わせて折る
Fold the corner
to the center.

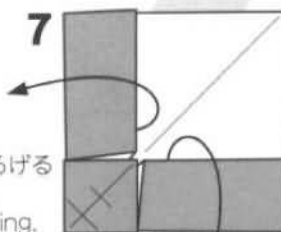

7
全部ひろげる
Unfold
everything.

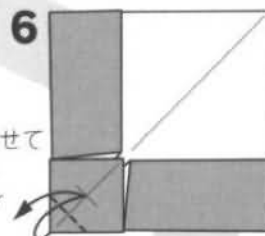

6
つけた印に合わせて
折り筋をつける
Fold the corner
to the mark.

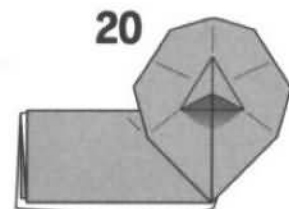
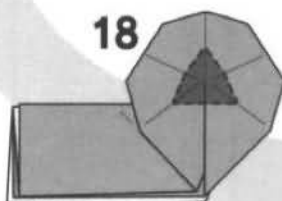
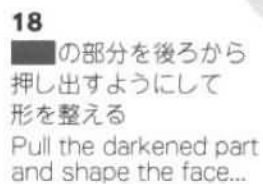
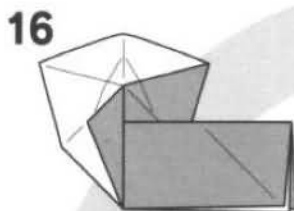
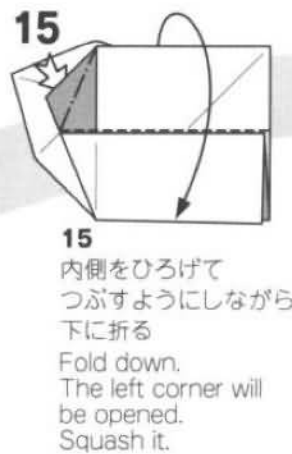
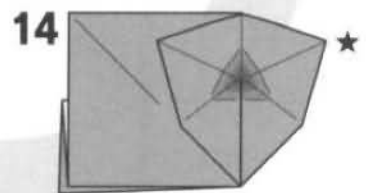
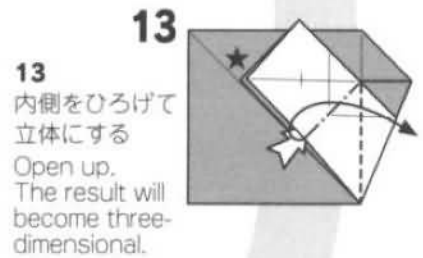
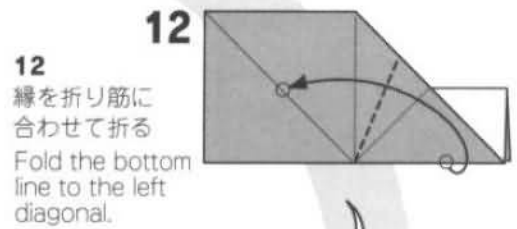
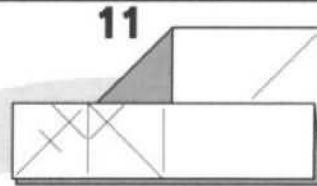
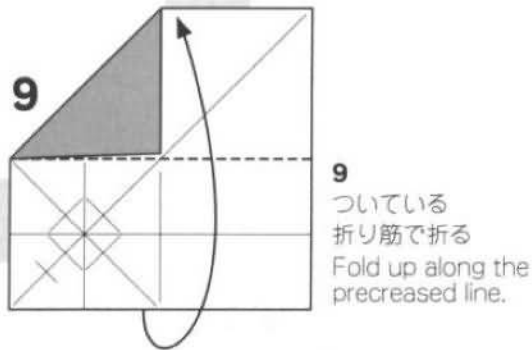
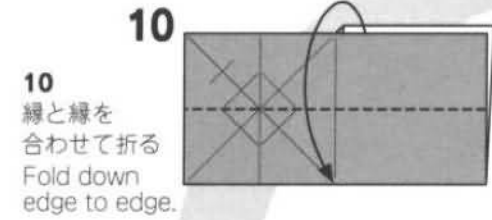

できあがり
 Model Completed

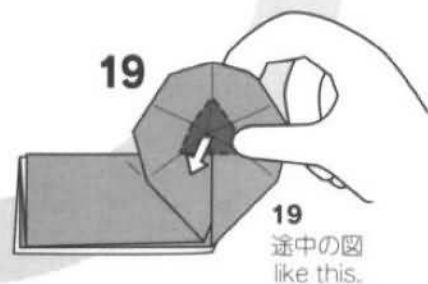

岩の上の鷹

A Hawk on a Rock

本書の中では「カニ」の次に古い創作です。脚と尾羽が同時に現れるのが見どころでしょうか。鷹の頭を上手く仕上げるためには薄手の紙を用いるのが良いでしょう。

The second oldest creation in this book. The legs and the tail are formed by the same sequence of folds. Use a thin piece of paper to fold the head well.



Created 1980 Paper 不切正方一枚折り: 1 piece

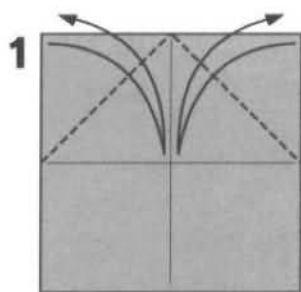

1 カドを中心に
合わせて
折り筋をつける
Fold the top
corners to
the center.

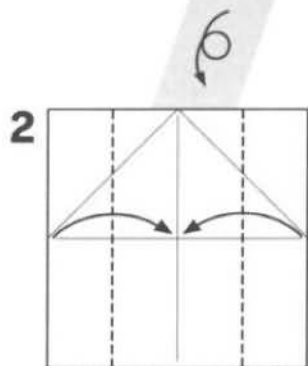

2 縁を中心に
合わせて折る
Fold the edges
to the center line.

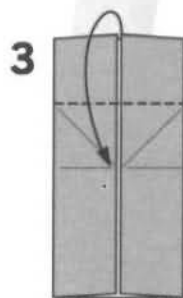

3 縁を折り筋に
合わせて折る
Fold down along
the quarter line.

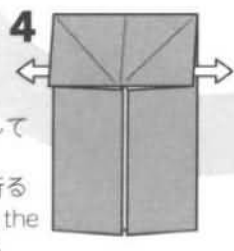

4 カドを
引き出して
つまむ
ように折る
Pull out the
corners.

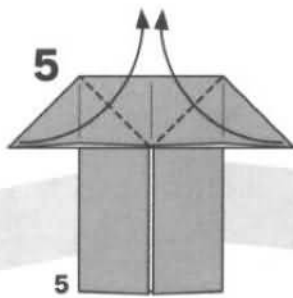

5 カドを上
に折る
Fold up the
corners.

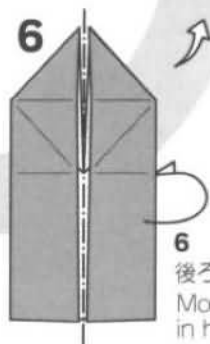

6 後ろへ半分に折る
Mountain fold
in half.

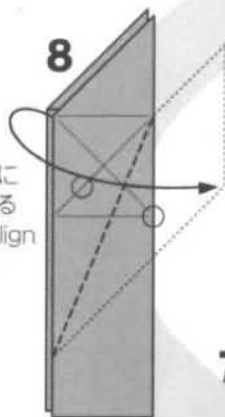

8 折り筋を縁に
合わせて折る
Fold and align
the circled
points.

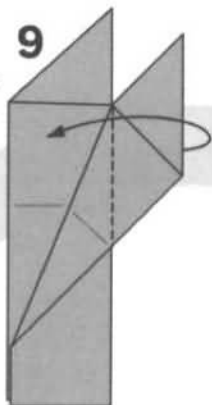

9 ついている折り筋で
カドを反対側に折る
Valley fold along
the edge.

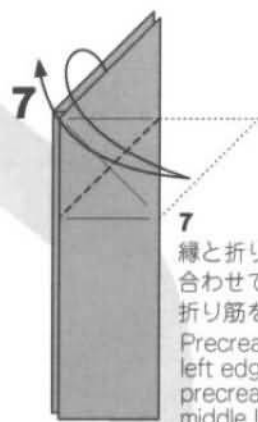

7 縁と折り筋を
合わせて
折り筋をつける
Precrease the
left edge to the
preceased
middle line.

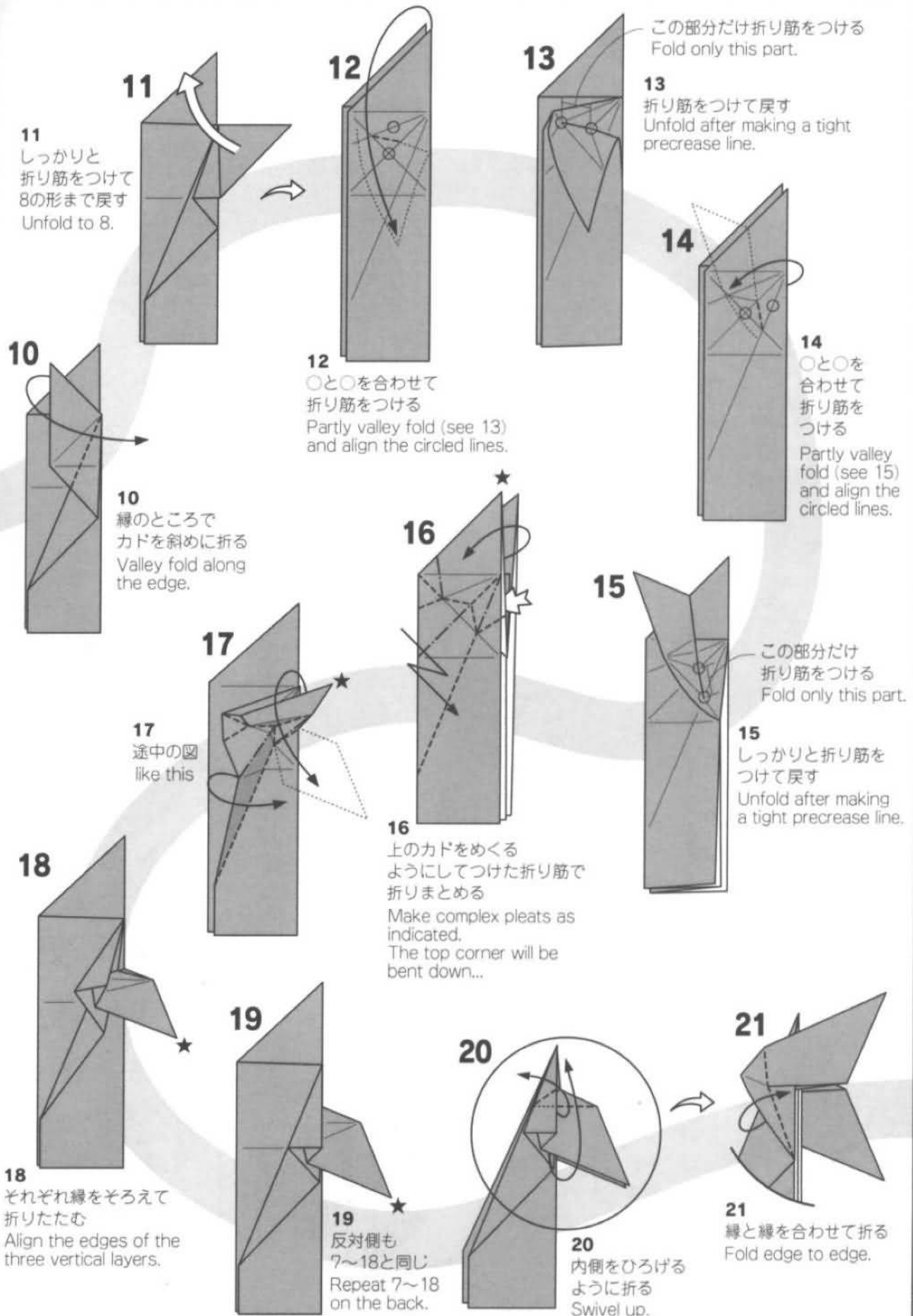

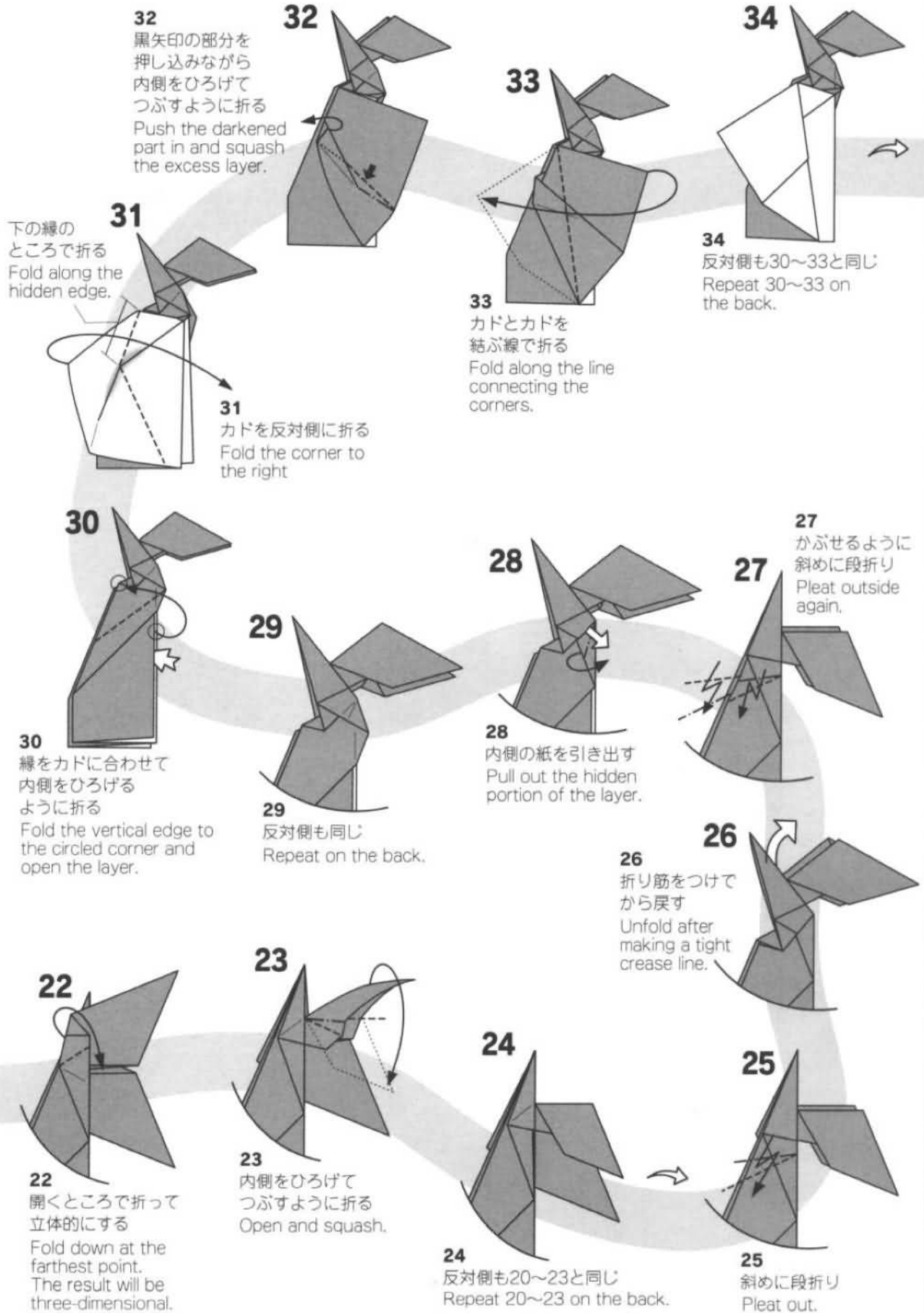

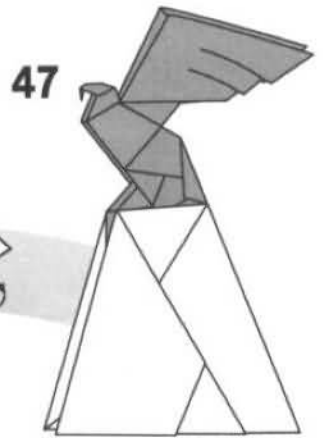
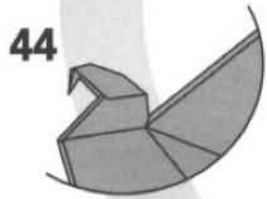
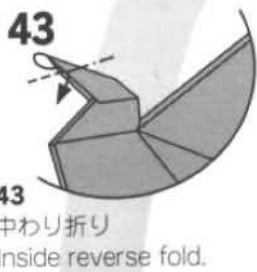
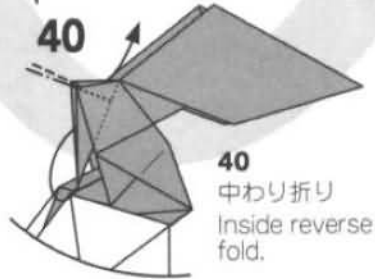
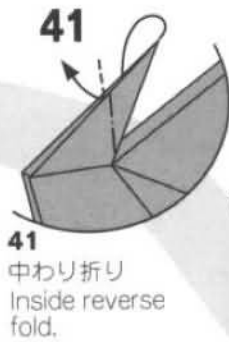
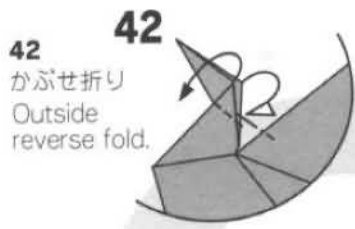
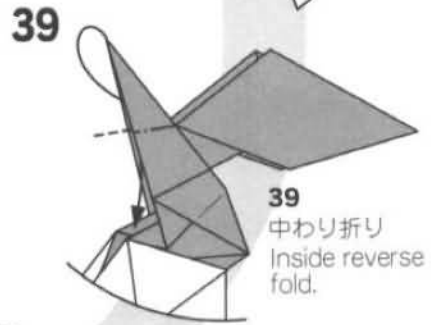
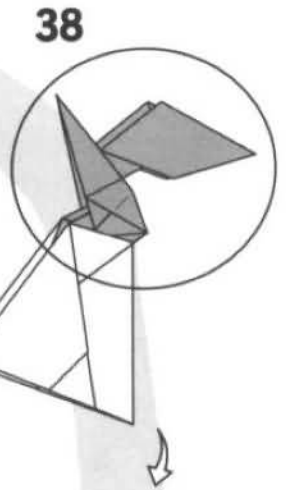
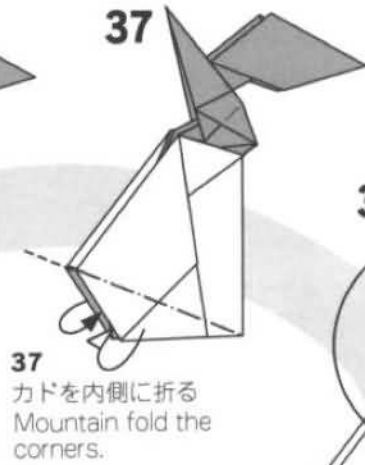
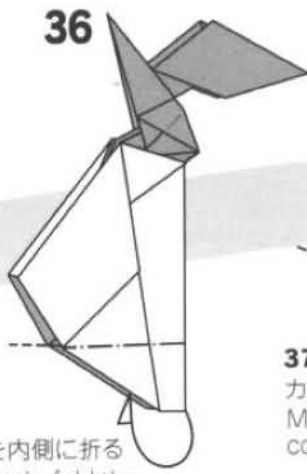
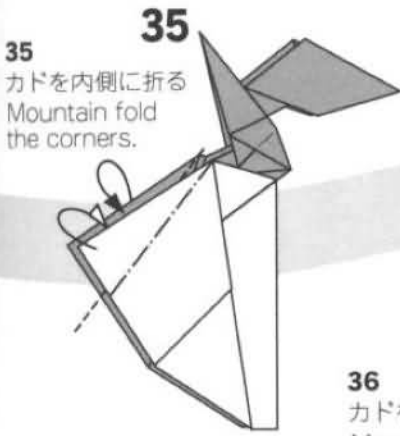

できあがり
Model Completed

45
尾羽の部分を折る
Fold the corners to the left and form the tail feathers.

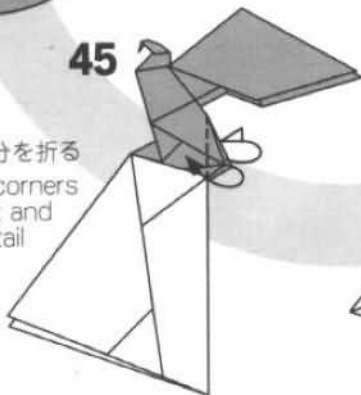

46
斜めに段折りをして翼の形を整える
反対側も同じ
Shape the wings by pleats. Repeat on the back.

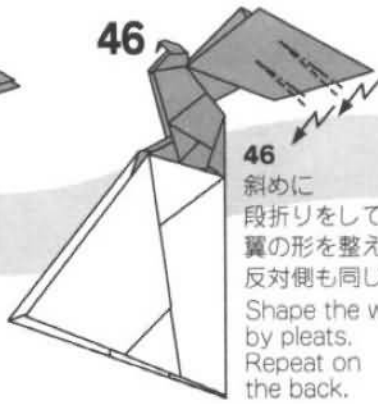

セキレイ

Wagtail

セキレイの目のあたりのインサイドアウトがグロテスクにならずに上手く決まって幸運でした。尾の根本には紙の重なりが急に変わる部分があるので、尾を折るときに紙を破らないように注意して仕上げてください。

The eyes are formed using the inside-out technique. The tail must be formed carefully, as there are layers of different sizes inside.

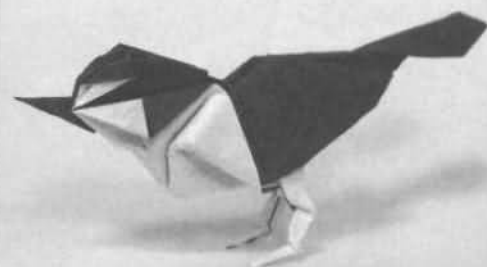

Created 1995 Paper 不切正方一枚折り: 1 piece

P. 60 [カンガルー] の [上半身] 8の形からはじめる
Start with No. 8 of [Kangaroo's Upper Part] (P. 60)

1
カドとカドを
合わせて
折り筋をつける
Precrease corner
to corner.

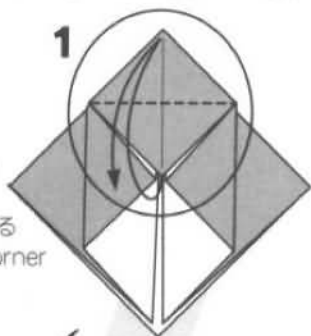

2
カドを中心に
合わせて
折り筋をつける
Precrease the
side corners to
the center.

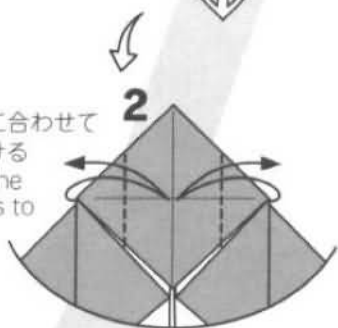

3
カドを中心に
合わせて
折り筋をつける
Precrease the top
corner to the center.

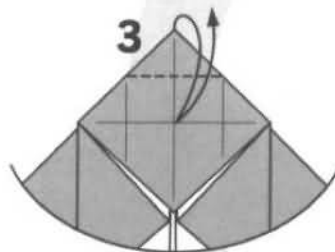

4
線と線に合わせて
折り筋をつける
Precrease along
the half line.

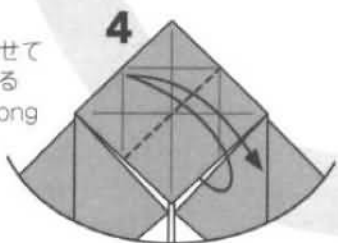

5
線と線に合わせて
折り筋をつける
Precrease
along the half
line.

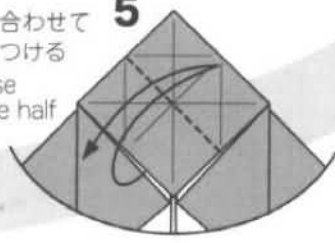

8
★のカドをつまんで
黒矢印の部分を押して
全体を起こしながら
つぶすように折る
Pinch the starred
corner and fold up
while squashing.
Push the arrowed
edge in.

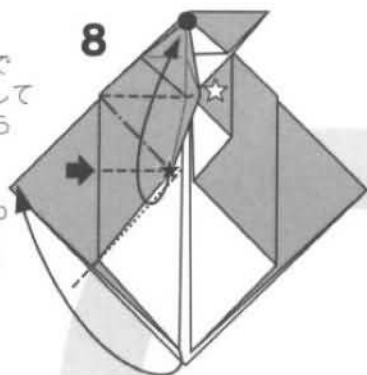

7
●のカドをつまんで
黒矢印の部分を押して
全体を起こしながら
つぶすように折る
Pinch the circled
(left) corner and
push the arrowed
edge in while folding
up. Squash the layer
pulled up.

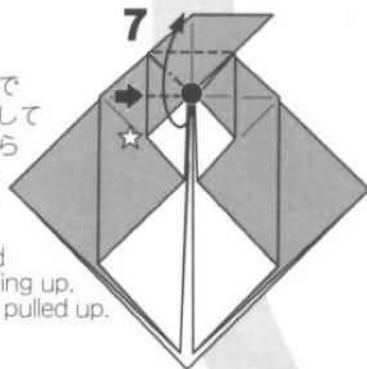

6
つけた折り筋を使って
内側をひろげて
つぶすように折る
Pinch the corner and
open the top layer.
Squash the sides.

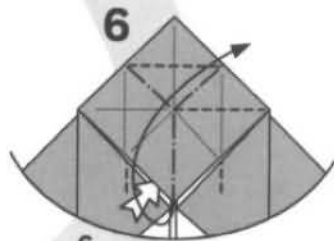

10
カドを反対側に折る
Fold the top corner to the left.

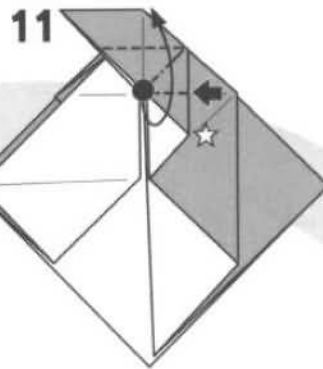
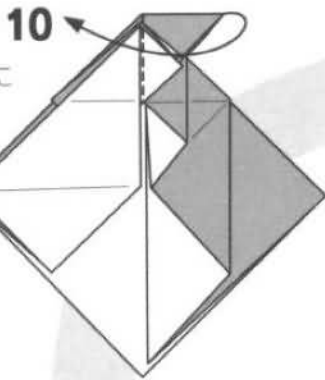

11
●のカドをつまんで黒矢印の部分を押して全体を起こしながらつぶすように折る
Pinch the circled corner and push the arrowed edge in while folding up. Squash the layer pulled up.

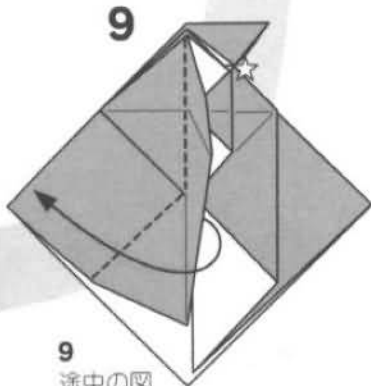

9
途中の図
The excess layer will stand up. Fold it to the left using the existing lines.

12
★のカドをつまんで黒矢印の部分を押して全体を起こしながらつぶすように折る
Pinch the starred corner and fold up while squashing. Push the arrowed edge in.

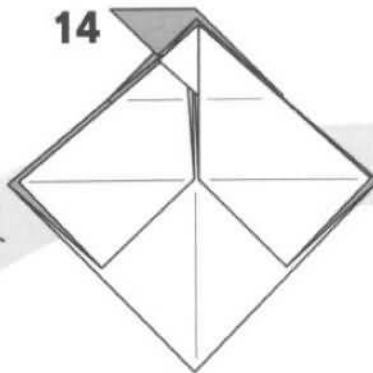
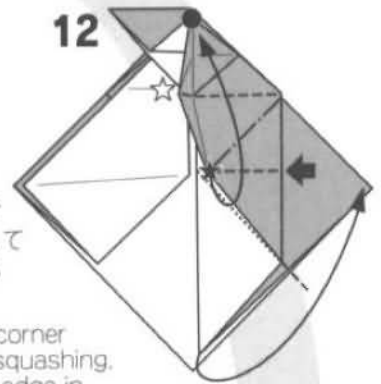

15
カドを1枚だけ開くところで下に折る
Swivel down only the top layer.

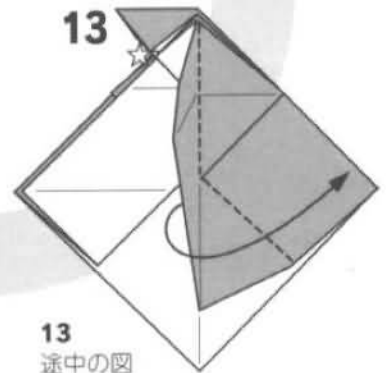
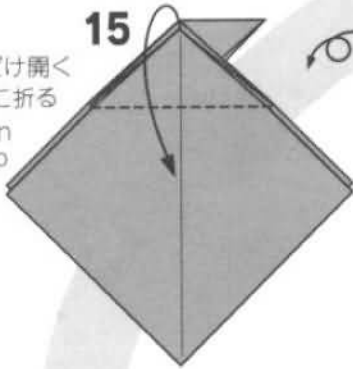

13
途中の図
The excess layer will stand up. Fold it to the right using the existing lines.

16
カドを上の上の1枚だけ開くところで下に折る
Swivel down only the top layer.

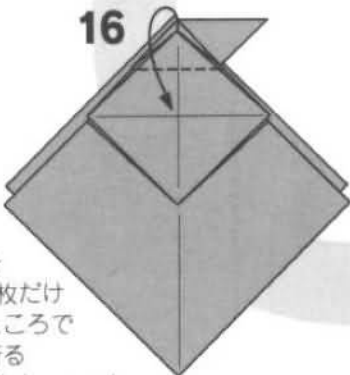

17
折り筋をつける
Precrease corner to corner.

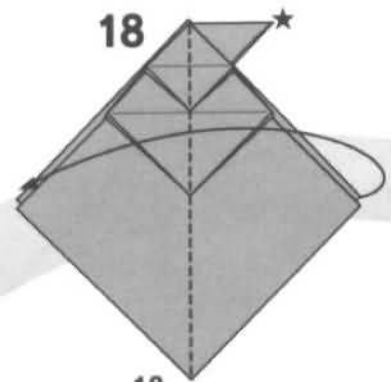
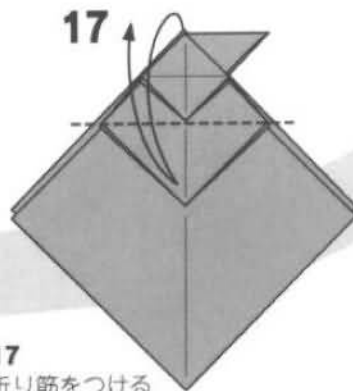

18
半分に折る
Fold in half.

27

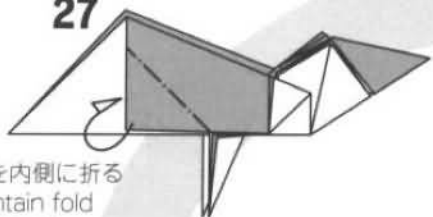

27
カドを内側に折る
Mountain fold
the corner.

28

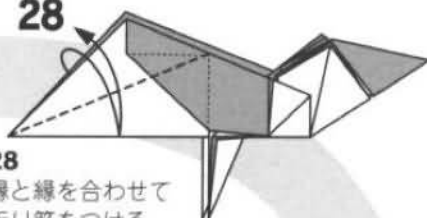

28
線と線に合わせて
折り筋をつける
Pcrease the left
edge to the bottom.

29

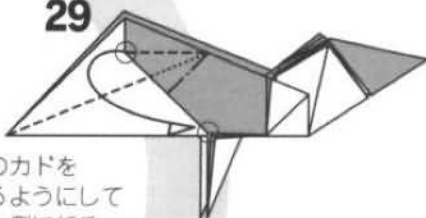

29
○と○のカドを
合わせるようにして
カドを内側に折る
Fold the circled corners
on top of each other
using the line made in 28.

26

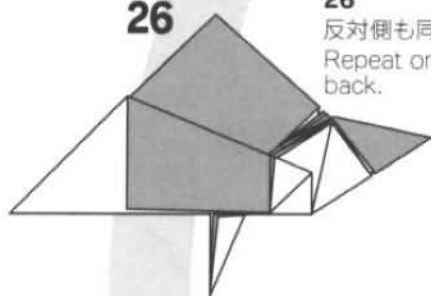

26
反対側も同じ
Repeat on the
back.

30



30
反対側も27~29と同じ
Repeat 27~29 on
the back.

25

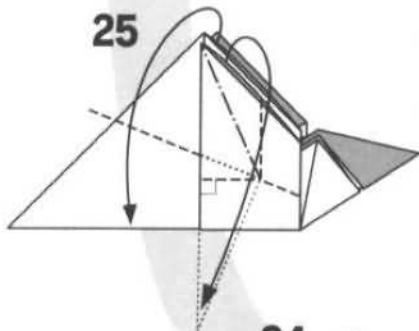

25
つけた折り筋を使って
カドを細くつまみながら
折りたたむ
Narrow the right part
along an angle bisector
and fold down along the
existing line.

24

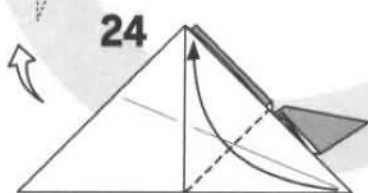

24
カドを戻す
反対側も21~24と同じ
Swivel back the corner.
Repeat 21~24 on the back.

23

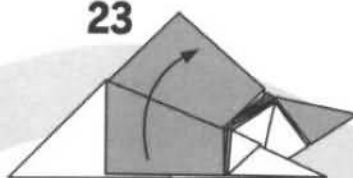

23
折り筋をつけて戻す
Unfold.

22

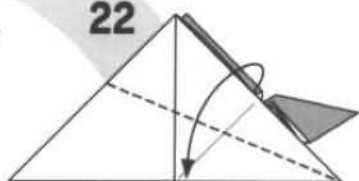

22
線と線に合わせて折る
Fold the edge to the bottom.

19

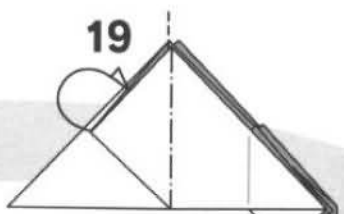

19
カドを内側に折る
反対側も同じ
Inside reverse fold.
Repeat on the back. ★

20

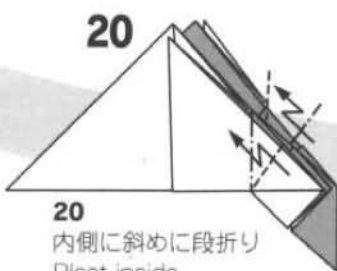

20
内側に斜めに段折り
Pleat inside.

21



21
カドを開くところで折る
Swivel down along the
inner edge.

少し開ける
Leave a little length.

32
カドとカドを合わせて
折り筋をつける
Precrease corner
to corner.

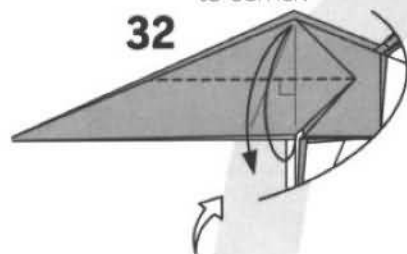

32

33

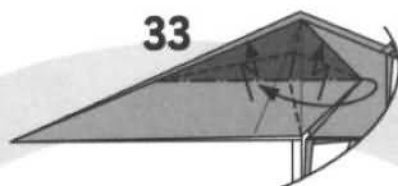

33
32でつけた折り筋を
山折りにして■の部分
を開くようにしながら
カドを反対側に折る
Open sink the darkened
part using precrease lines.

34

段になっているところの紙の
重なりはそのまま黒矢印の
部分を押し込んでずらすように
縁と縁を合わせて折る
Slide the tail down while
pushing the arrowed
corner down (a kind of
open sink).
Do not change the layered
structure.

34

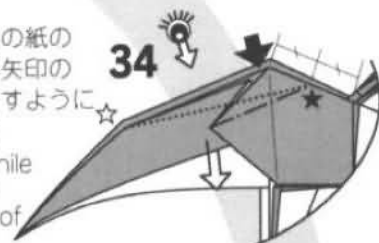

31
カドを反対側に折る
Swivel the corner to the right.

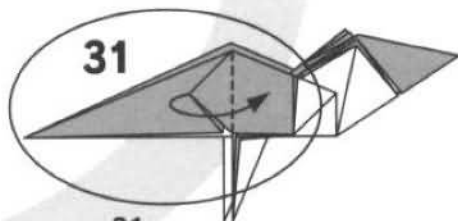

31

35

開いて上から見た図
図のような折り線で
折りたたむ
The top view.
34 uses the crease
lines as shown.

35

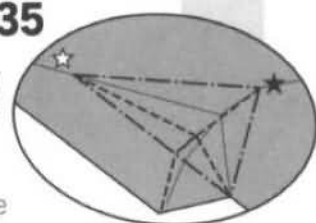

37
カドを内側に折る
反対側も同じ
Mountain fold the corner.
Repeat on the back.



37

36

反対側も31~35と同じ
Repeat 31~35 on the back.

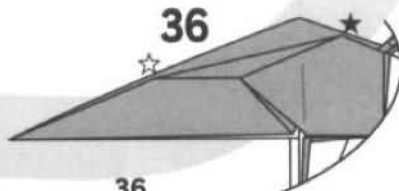

36

38
中わり折り
Inside reverse fold.



38

39
中わり折り
Inside reverse fold.

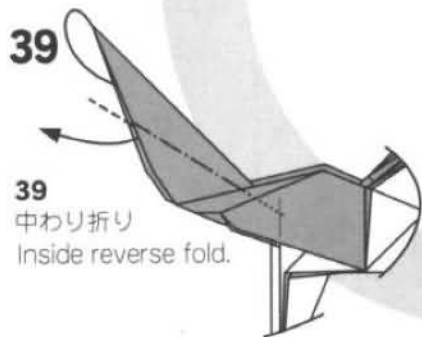

39

41

カドを内側に折る
Inside reverse fold.



41

40
開くところで
折り返す
Swivel down.

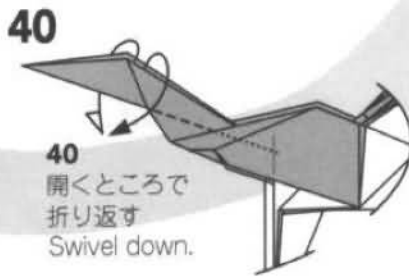

40

53
カドを少し
折り下げる
Fold down
a little.

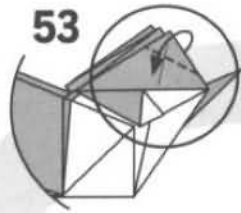

54
上の一枚をずらす
ように折る
Slide up the
top layer.

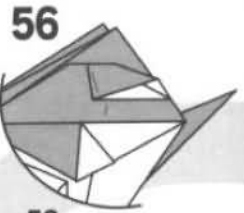
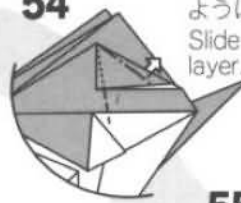

56
反対側も51~55と
同じ
Repeat 51~55
on the back.

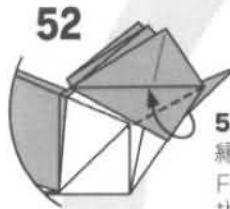

52
縁と縁を合わせて折る
Fold the right edge to
the middle one.

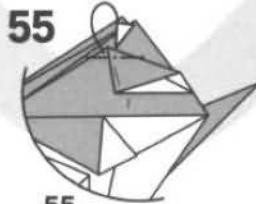

55
カドを内側に
折り込む
Mountain fold
the corner.

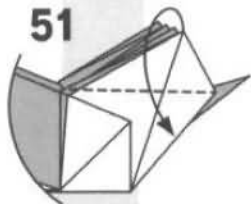

51
上の1枚のカドを
下に折る
Fold down the
top layer.

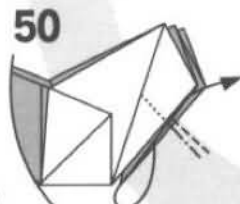

50
内側のカドを
中わり折り
Inside reverse fold
the inner corner.

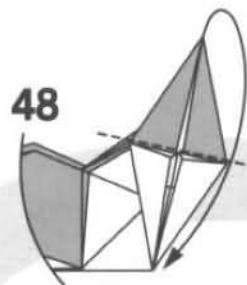

48
カドを下に折る
Swivel down.



47
縁のところで
折る
Fold along the
edges.

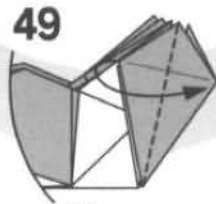

49
カドを反対側に折る
Close the opening again.

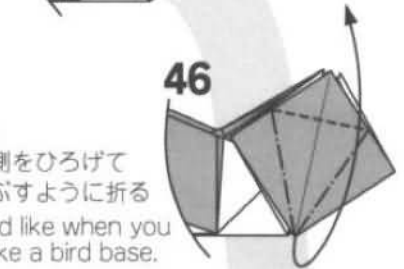

46
内側をひろげて
つぶすように折る
Fold like when you
make a bird base.



42
カドを内側に折る
Inside reverse fold.

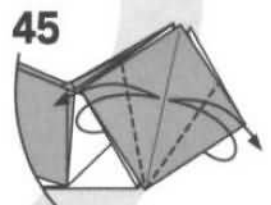

45
縁を折り筋に
合わせて
折り筋をつける
Fold the lower
edges to the
center.

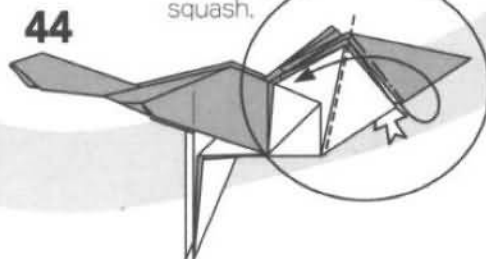
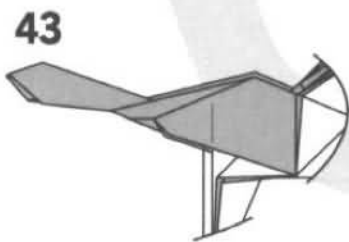

44
内側をひろげて
つぶすように折る
Open and
squash.

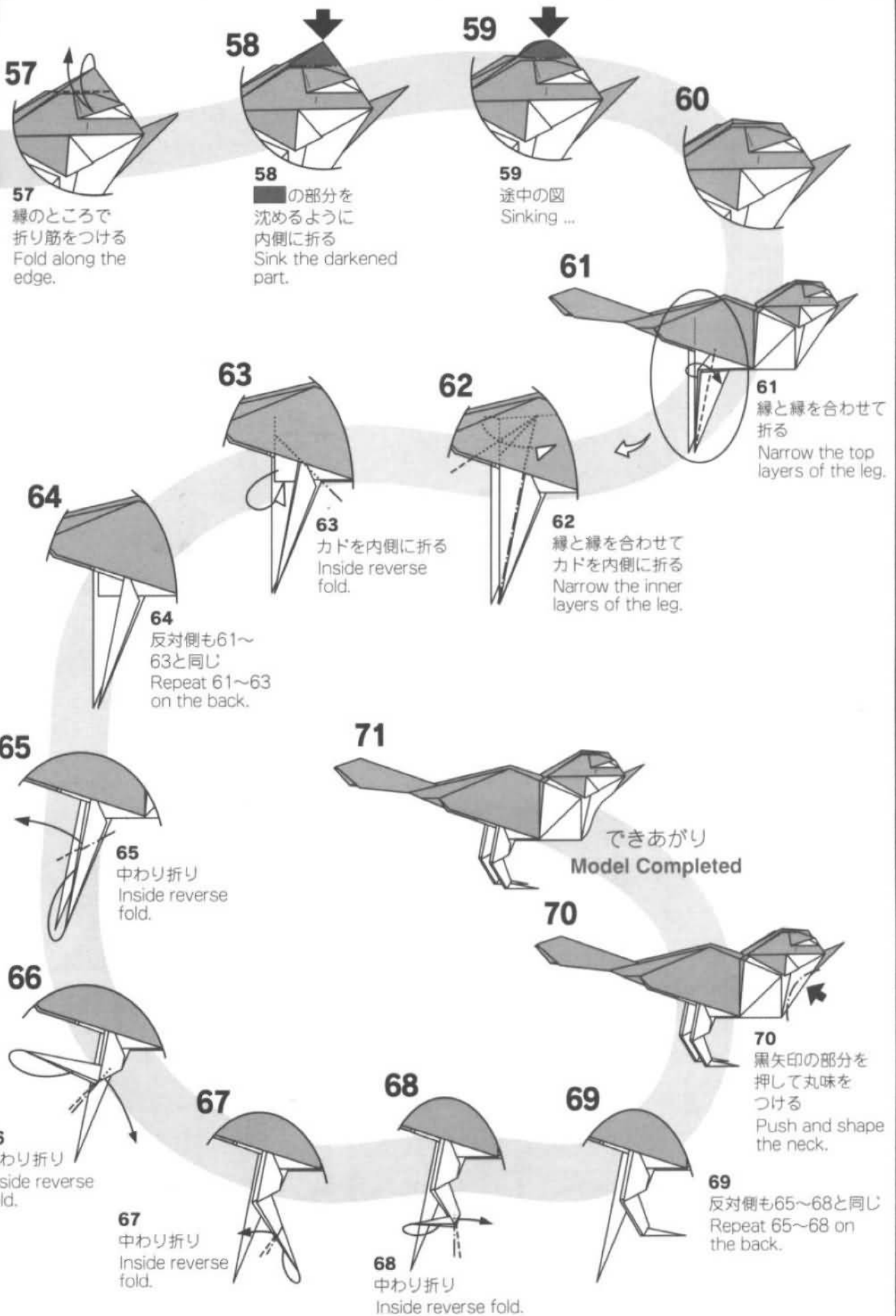

始祖鳥

Archaeopteryx

吉野一生さんの“馬”（「一生スーパーコンプレックスおりがみ」所収）が完成してゆく様を間近で見っていた私は、平面に折りによる変化を与えるというテーマを得ました。始祖鳥でこの課題に挑戦したものです。恐竜折り紙5人展（ギャラリーおりがみはうす1990年）へ出展。

Inspired by Yoshino Issei's "Horse", I tried to give varied patterns to a plane. The model was exhibited in "An Exhibit of Five Dinosaur Folders" at the Gallery Origami House.



Created 1990 Paper 不切正方一枚折り: 1 piece

1
三角に折り筋をつける
Fold along the diagonals.

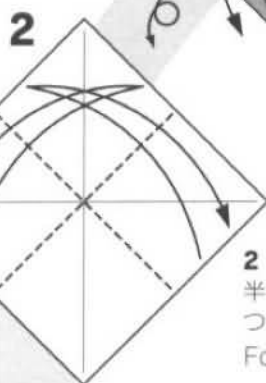
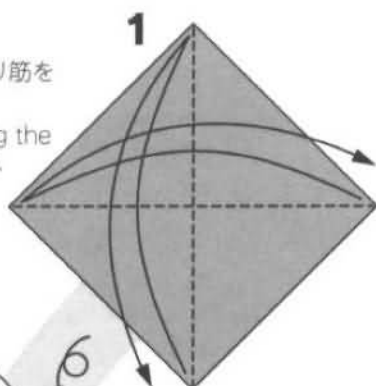

2
半分に折り筋をつける
Fold in half.



3
縁を中心に合わせて
折り筋をつける
Precrease the edges to the diagonal.

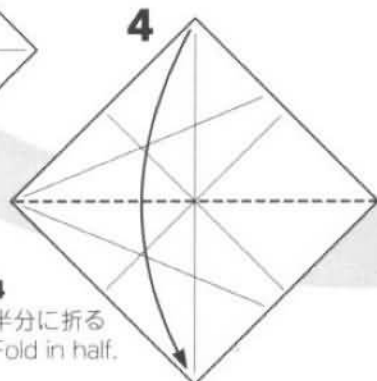

4
半分に折る
Fold in half.

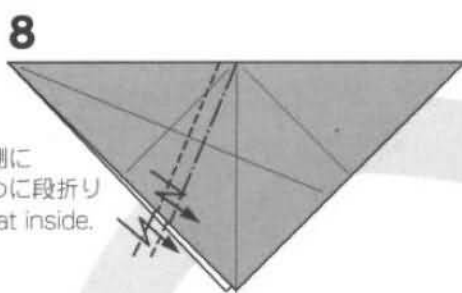

8
内側に
斜めに段折り
Pleat inside.

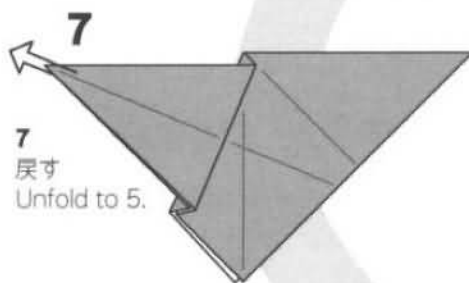

7
戻す
Unfold to 5.

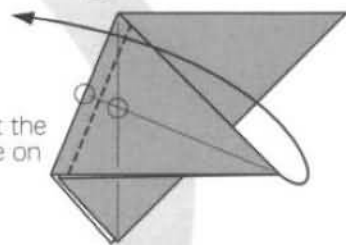

6
折り筋の交点を
縁に合わせて折る
Valley fold so that the intersection will be on top of the edge.

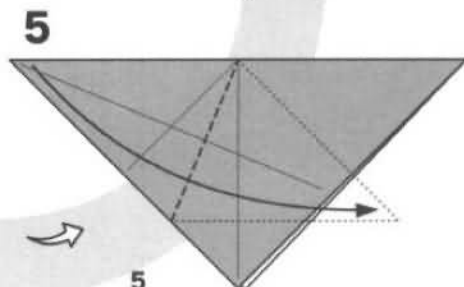

5
縁を折り筋に合わせて
斜めに折る
Fold and align the left crease line to the center line.

11
カドを内側に折る
Inside reverse folds.

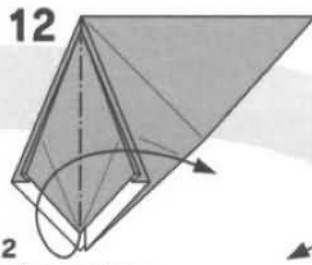
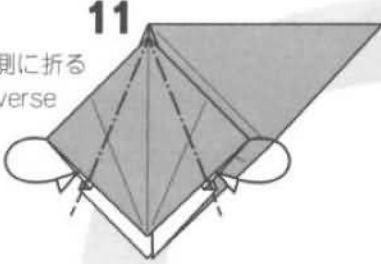

12
内側をひろげて
つぶすように折る
Swivel open to the
right and squash.

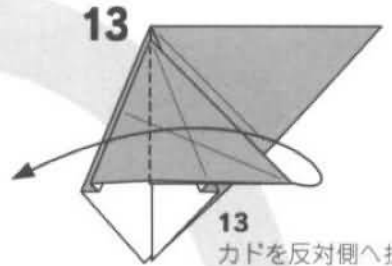

13
カドを反対側へ折る
Swivel to the left.

10
中心に合わせて
折り筋をつける
Fold the edges to
the diagonal.
Unfold.

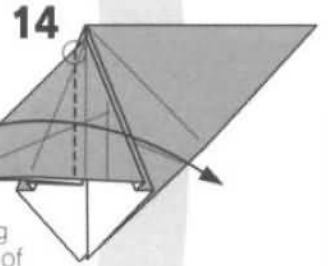
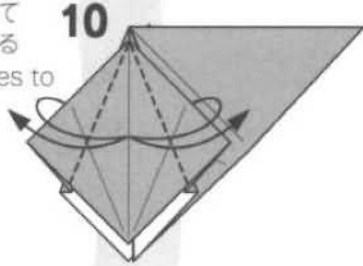

14
縁と縁の交点で
カドを反対側
へ折る
Swivel to the right
along the line starting
with the intersection of
the edges on the left.

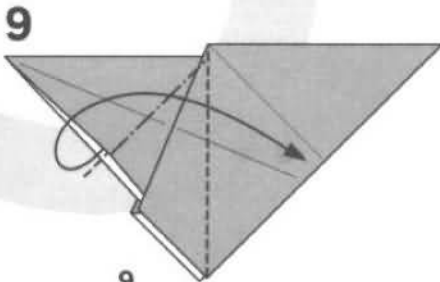

9
内側をひろげて
つぶすように折る
Open and squash.

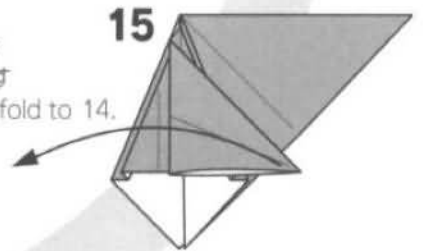

15
戻す
Unfold to 14.

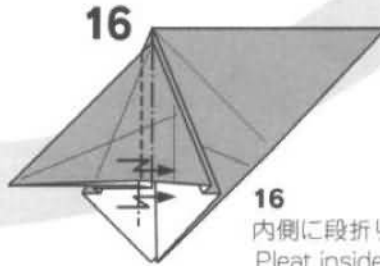

16
内側に段折り
Pleat inside.

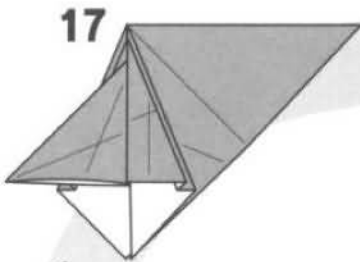

17

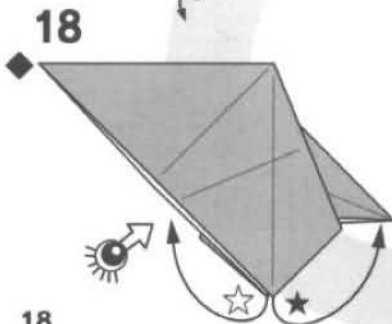

18
内側をひろげて見る
Open up.
The inside views follow.

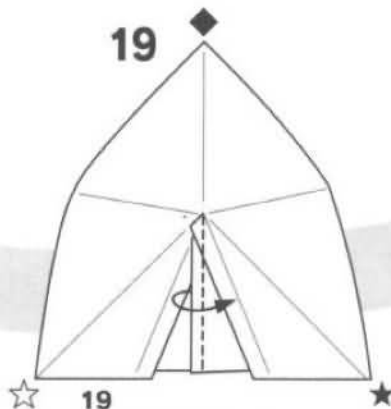

19
縁を反対側へ折る
Swivel the edge to the right.

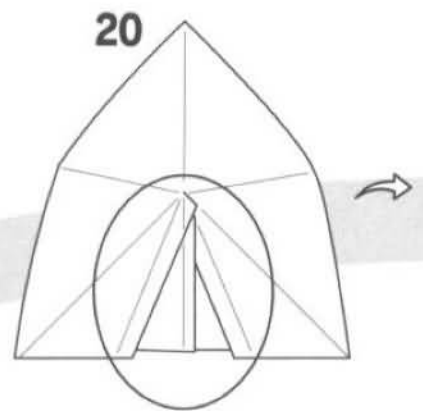

20

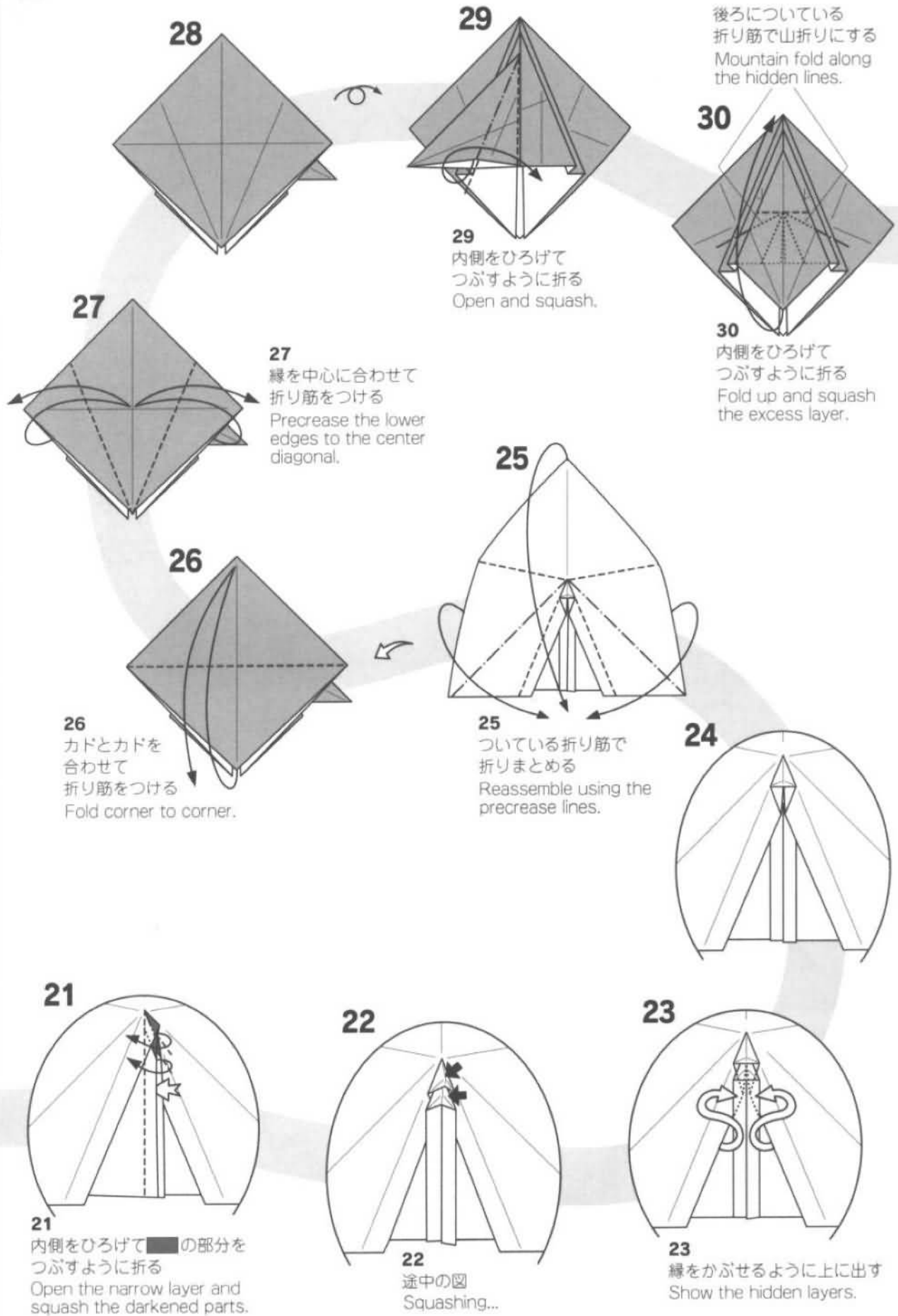

30で山折りにしたところ
The mountain fold in 30.

31

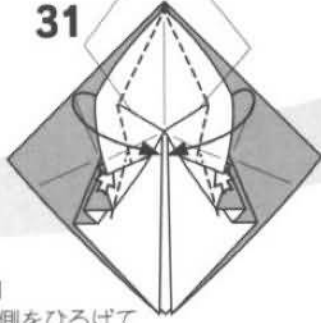

31
内側をひろげて
つぶすようにしながら
縁を中心に合わせて折る
Open and squash the
small pockets in the middle
while folding the edges
to the center diagonal.

32

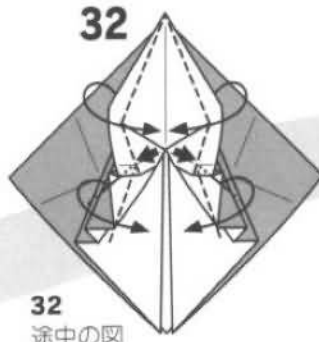

32
途中の図
黒矢印のところを押し込む
ようにして折りたたむ
Push and squash the
arrowed parts.

33

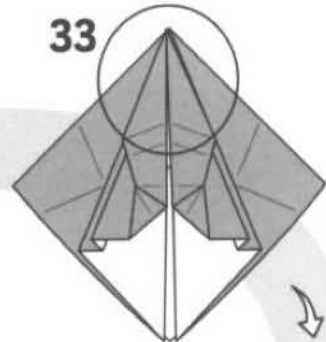

34
上のカドを折り筋に
合わせて折る
Fold the top corner
to the intersection.

34

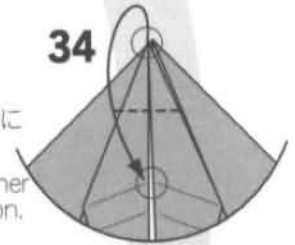

35

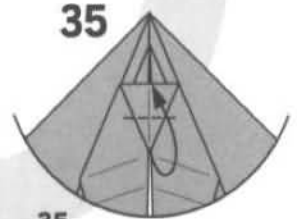

35
カドを縁に合わせて折る
Fold the corner to the
top edge.

36

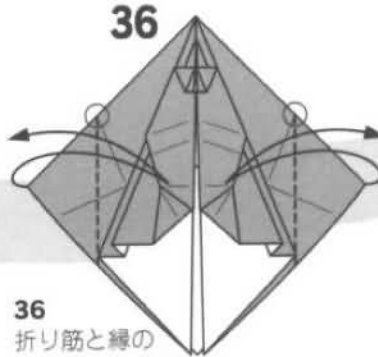

36
折り筋と縁の
交点のところで
カドを折り筋に合わせて
折り筋をつける
Fold the side corners along
the line starting from the
circled intersection to the
crease line.

37

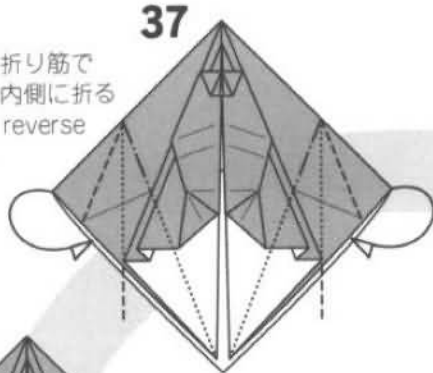

37
つけた折り筋で
カドを内側に折る
Inside reverse
folds.

38

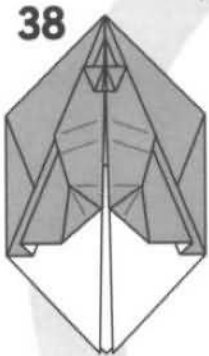

39
開くところで
カドを上折る
Swivel up.

39

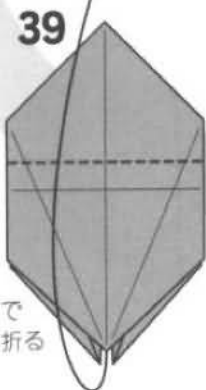

40

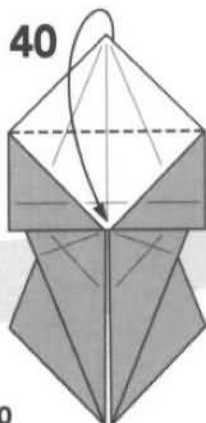

40
カドを縁に合わせて折る
Fold the top corner
to the edge.

41

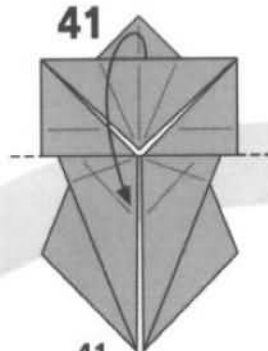

41
縁を下に折る
Swivel down.

42

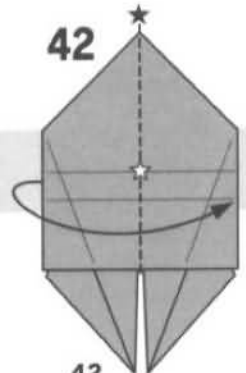

42
半分に折る
Fold in half.

53
 縁に沿ってカドを
 内側に折る
 Inside reverse
 fold along the
 edge.

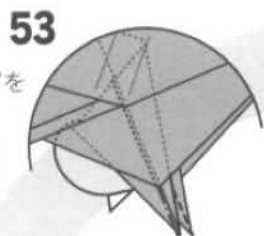

54
 縁と縁を合わせて
 カドを内側に折る
 Inside reverse fold
 along the edge.

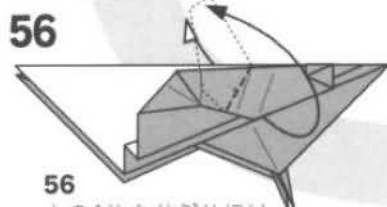

55
 上の1枚をかぶせ折り
 Outside reverse fold
 the top layer.

52
 縁に沿ってカドを
 内側に折る
 Inside reverse fold
 along the edge.



51
 反対側も46~50と同じ
 Repeat 46~50 on the
 back.

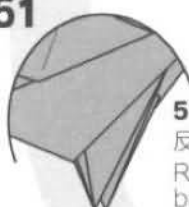

50
 縁と縁を合わせて
 カドを内側に折る
 Align the edges by an
 inside reverse fold.

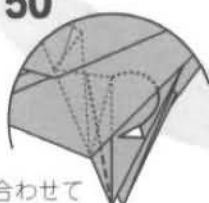

49
 ついている折り筋で
 カドを内側に折る
 Inside reverse fold
 using the precrease
 line.

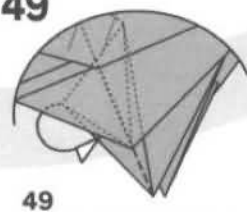

48
 折り筋と縁を
 合わせて
 カドを内側に折る
 Inside reverse fold
 and align the line
 created in 46 with
 the edge.



47
 戻す
 Unfold.



46
 縁と縁を合わせて
 カドを内側に折る
 Valley fold along
 the angle bisector.

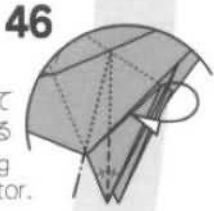

43
 内側のカドを
 斜めに段折りして
 内側の縁を
 ○のカドに合わせる
 Pleat the inner corner
 inside so that the middle
 edge comes below the
 circled corner.

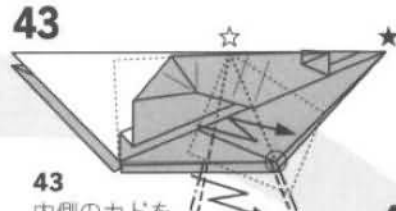

44
 カドを内側に折る
 Inside reverse fold.

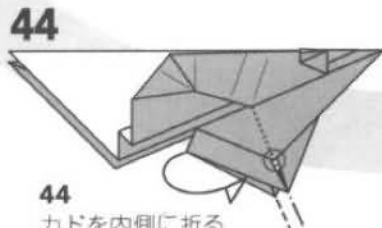

45

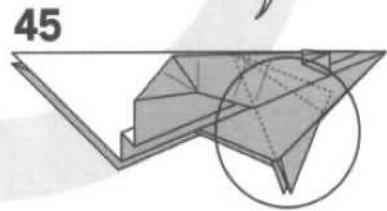

59

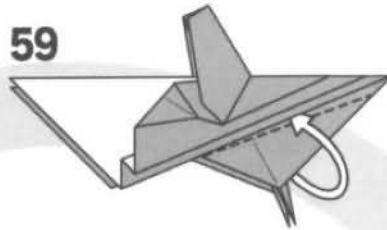

59

つけた折り筋を使って
カドをすき間に差し込む
Tuck the corner inside
using the crease line
in 57.

58

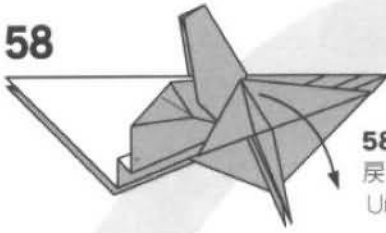

58
戻す
Unfold.

60

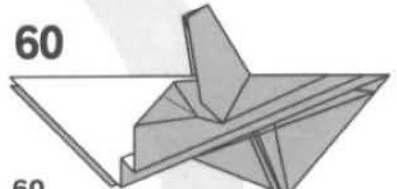

60
反対側も57~59と同じ
Repeat 57~59 on
the back.

57

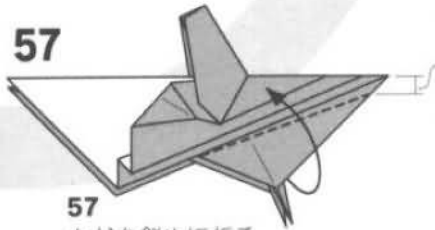

57
カドを斜めに折る
Fold up the corner.

ここを少し開けて折る
Do not sharpen the tail,
but leave a small
portion intact.

61

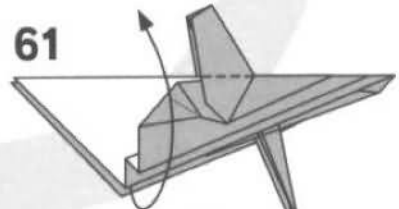

61
上の1枚を上折る
Swivel up.

62

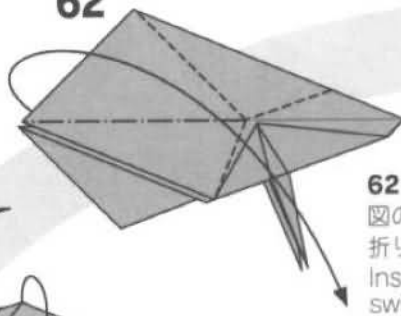

62
図のような折り筋で
折りまとめる
Inside reverse while
swiveling down.

63

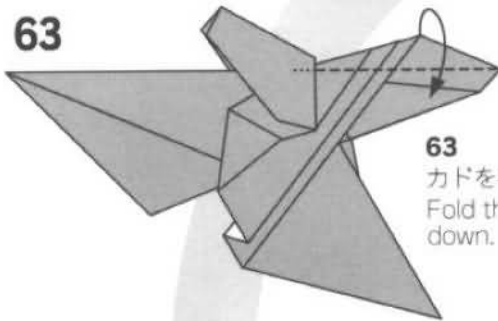

63
カドを手前に折る
Fold the corner
down.

64

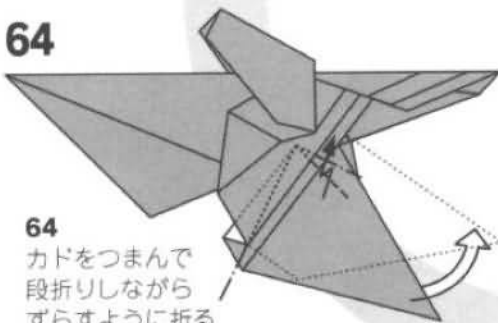

64
カドをつまんで
段折りしながら
ずらすように折る
Rotate the corner
a little while forming
a pleat.

66

66
カドを縁のところで
内側に折る
Tuck the corners
inside folding along
the edges.

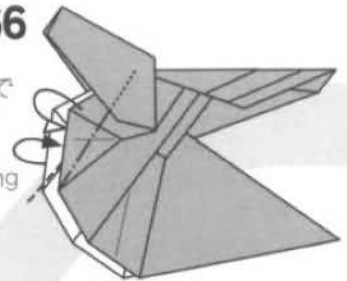

65

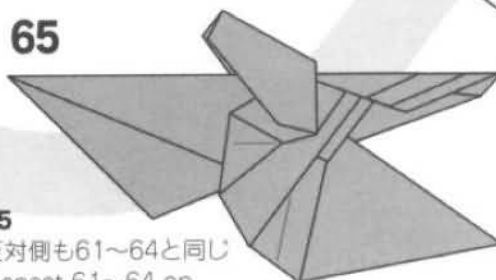

65
反対側も61~64と同じ
Repeat 61~64 on
the back.

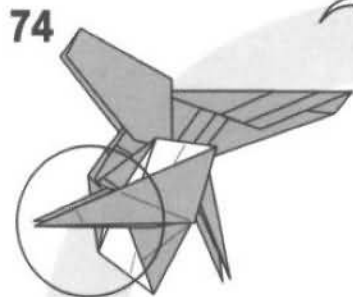

74

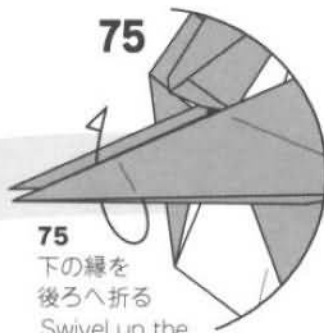

75

下の縁を
後ろへ折る
Swivel up the
hidden edge.

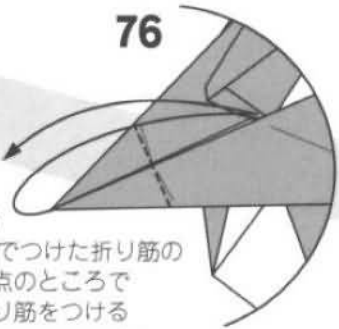

76

70でつけた折り筋の
交点のところで
折り筋をつける
Precrease at the
intersection of
the crease lines
made in 70.

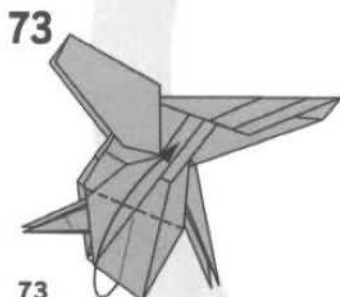

73

折り筋を
つけないように
開くところで
上に折る
Bend upwards.
Do not fold.

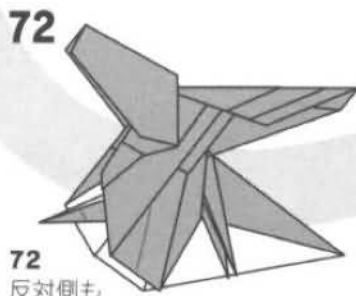

72

72
反対側も
67~71と同じ
Repeat 67~71
on the back.

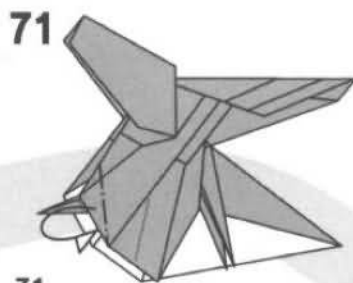

71

71
カドを後ろへ折る
Tuck the corner
inside.

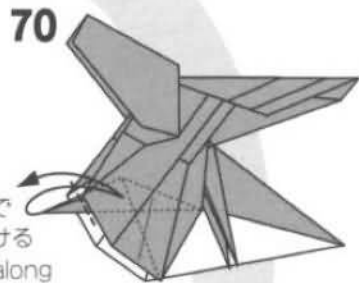

70

70
縁のところで
折り筋をつける
Precrease along
the edge.

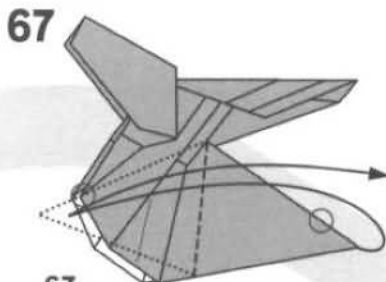

67

67
カドと縁を合わせて
折り筋をつける
Precrease so that the
circled edge will be aligned
with the circled corner.

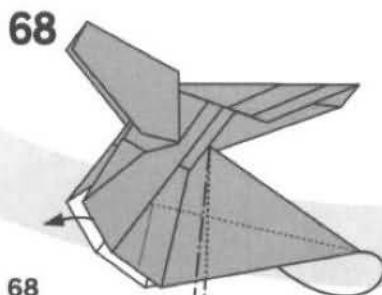

68

68
つけた折り筋を
使って中わり折り
Inside reverse fold
using the crease
line in 67.

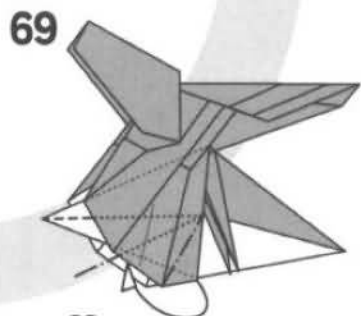

69

69
縁と縁を合わせて
カドを内側に折る
Narrow the corner
of the hidden layer
along the angle bisector.

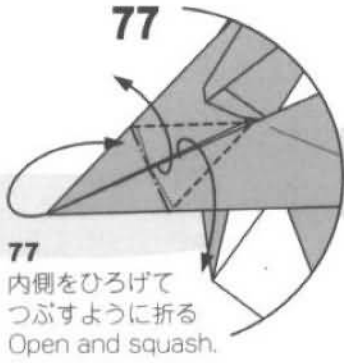

77
内側をひろげて
つぶすように折る
Open and squash.

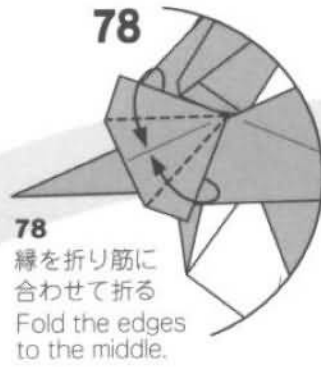

78
縁を折り筋に
合わせて折る
Fold the edges
to the middle.

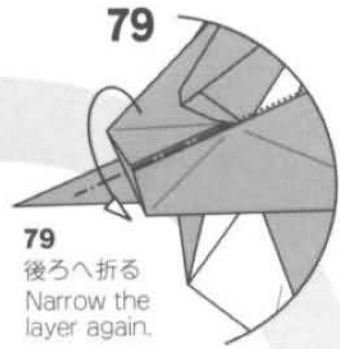

79
後ろへ折る
Narrow the
layer again.

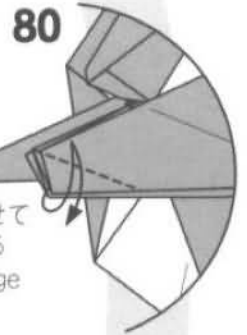

80
縁と縁を合わせて
折り筋をつける
Precrease edge
to edge.

83
■の部分
図のような折り筋で
折りまとめる
Reassemble the
darkened part
using the indicated
crease lines.

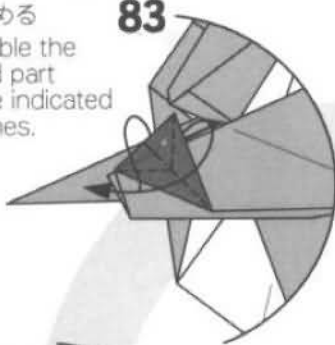

83

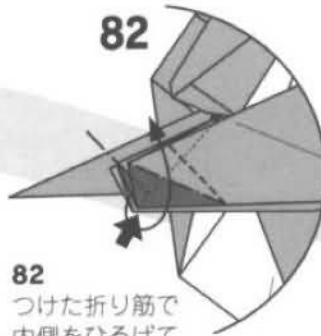

82
つけた折り筋で
内側をひろげて
つぶすように折る
Swivel open and
squash the
darkened part.

82



81
縁を折り筋に
合わせて
折り筋をつける
Precrease the left edge
to the crease line in 80.

81

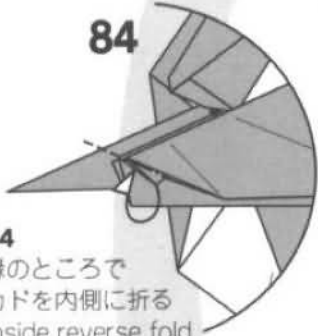

84
縁のところで
カドを内側に折る
Inside reverse fold
along the edge.

84

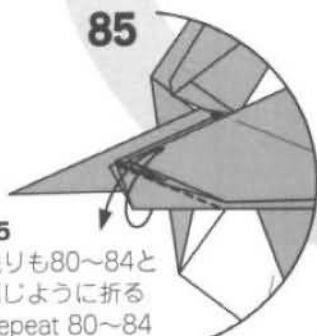

85
残りも80~84と
同じように折る
Repeat 80~84
on the next layers.

85

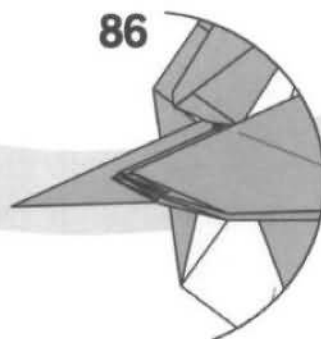

86

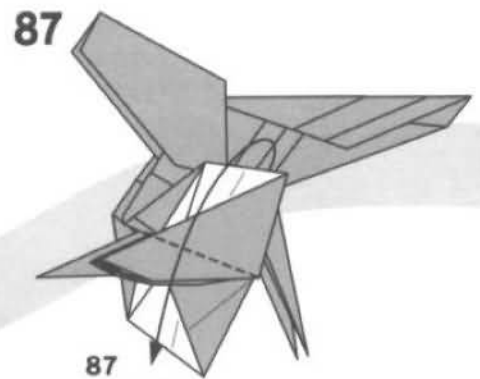

87
縁を戻す
Put down the
bended portion.

87



96
翼の部分を
左右にひろげて
内側を見る
Open the wings.

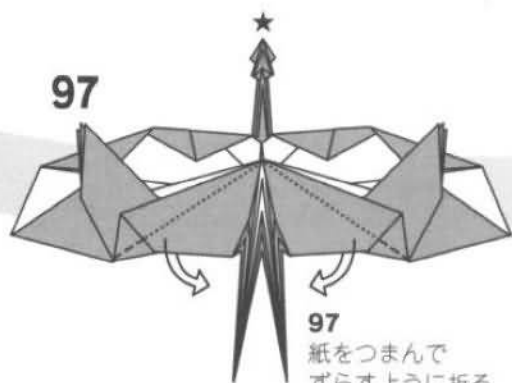

97
紙をつまんで
ずらすように折る
The inside view.
Slide down the layers.



95
下のカドを
引き出す
Pull down the
inner layer.

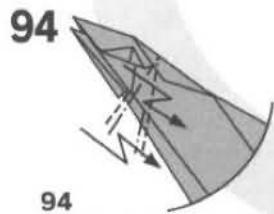

94
かぶせるように
段折り
Pleat outside.



93
カドを少し折る
反対側も同じ
Fold the corners up.
Repeat on the back.

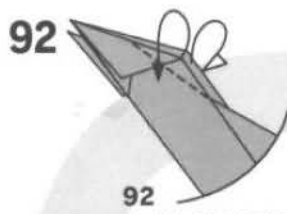

92
カドを斜めに折る
Fold the corners
down.



91
縁と縁を合わせて
カドを斜めに折る
Fold edge to edge.

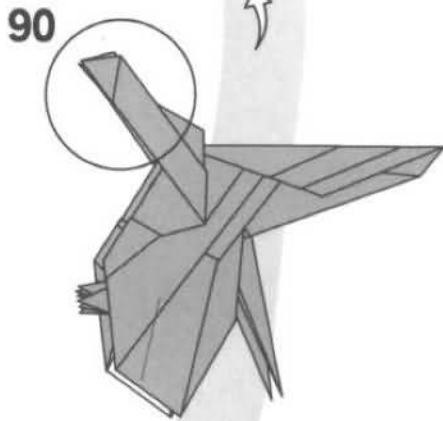

90

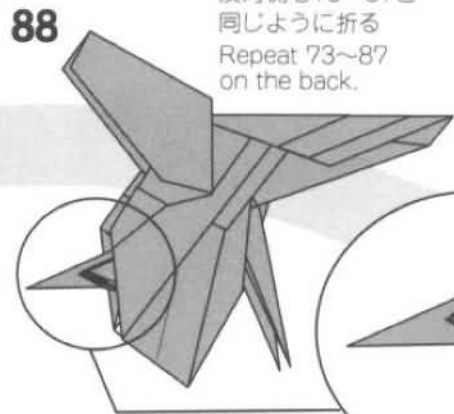

88
反対側も73~87と
同じように折る
Repeat 73~87
on the back.

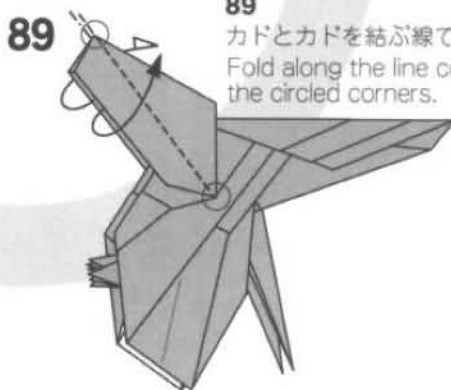

89
カドとカドを結ぶ線
で折る
Fold along the line connecting
the circled corners.

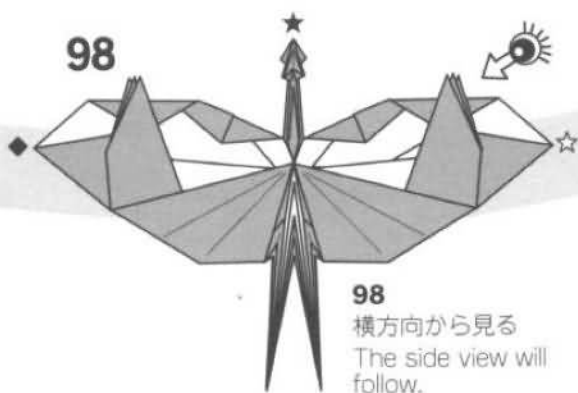

98
横方向から見る
The side view will follow.

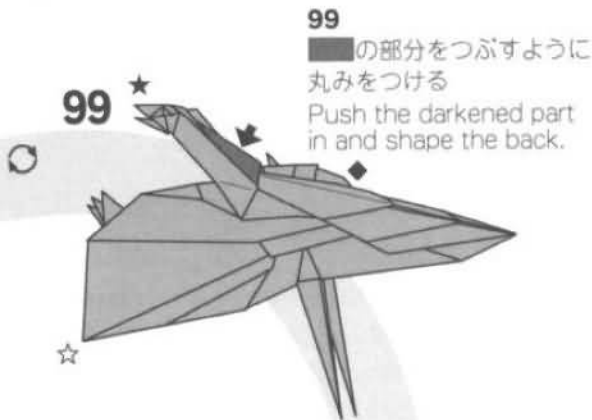

99
■の部分をつぶすように丸みをつける
Push the darkened part in and shape the back.

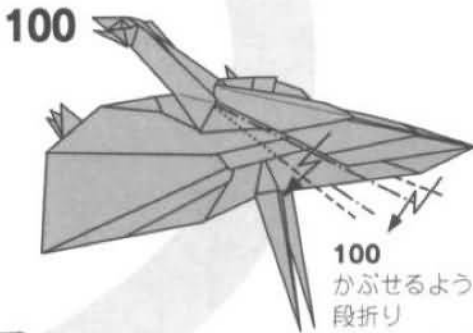

100
かぶせるように段折り
Pleat outside.

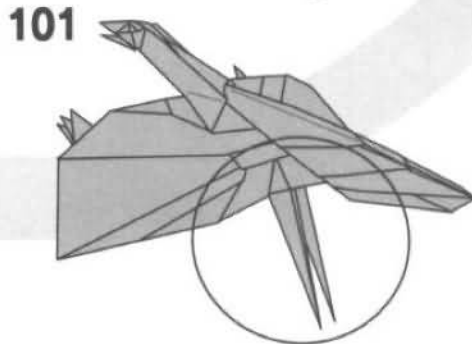

102
かぶせ折り
Outside reverse fold.



103
かぶせ折り
Outside reverse fold.

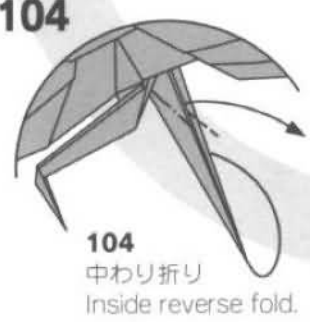

104
中わり折り
Inside reverse fold.

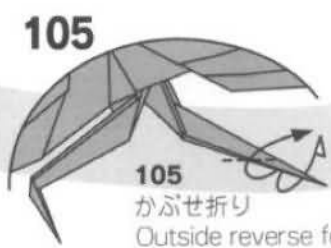

105
かぶせ折り
Outside reverse fold.

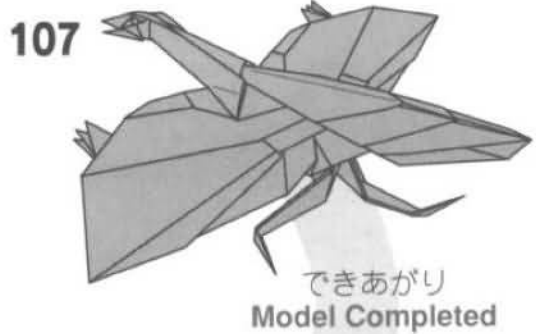
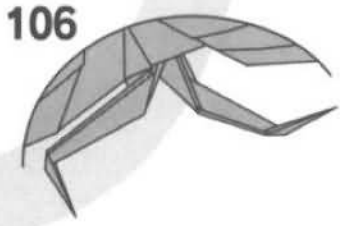

できあがり
Model Completed

カニ

Crab

本書の中で最も古い創作になります。中学2年の頃の創作で思い出深いものですので収録させてもらいました。構造は、大雑把に言って9個のツルと理解すべきものですが、折り出しの6図に直感的な魅力を感じたものと思われま。当時、折りまくった22図から31図がつぶし折りの鍛錬となっています。

The oldest creation in this book. I created it when I was a second year student in Junior High. You can see the structure of this model with nine origami crane patterns inside. 22-31 is hard with a series of squash folds.



Created 1977 Paper 不切正方一枚折り: 1 piece

1
3等分に折り筋をつける
Fold along the thirds of length.

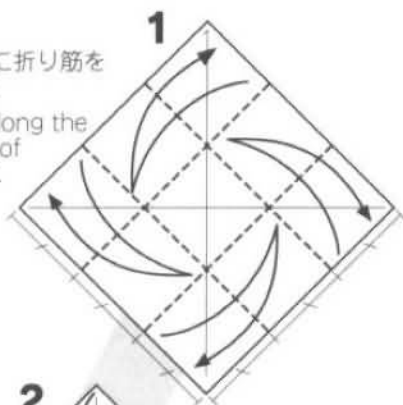

2
カドを折り筋の交点に合わせて折る
Fold the top and bottom corners to the nearest intersections.

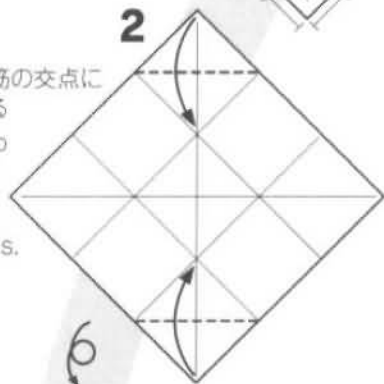

9
カドを内側に折る
Inside reverse fold.

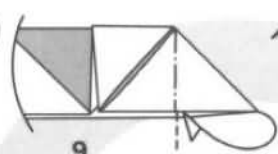

8
内側をひろげてつぶすように折る
Open and squash.

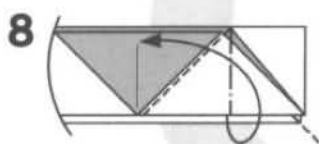

7
縁に沿って折り筋をつける
Precrease along the edge.

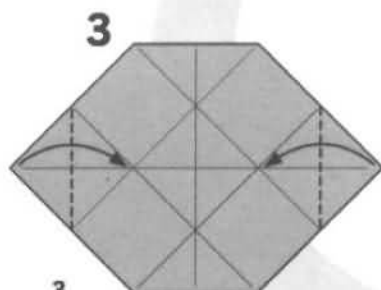
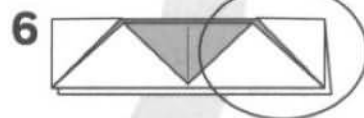
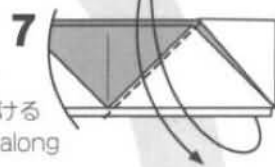

3
カドを折り筋の交点に合わせて折る
Fold the left and right corners to the nearest intersections.

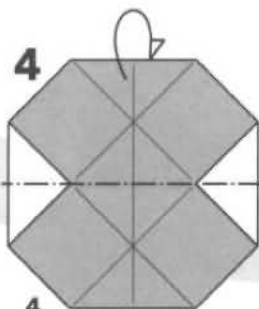

4
後ろへ半分に折る
Mountain fold in half.

5
カドとカドを結ぶ線で折る
反対側も同じ
Fold along the line connecting the middle corners. Repeat on the back.

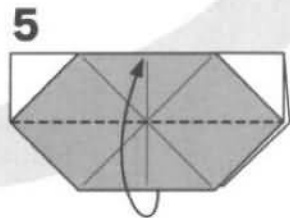

12

12
カドを反対側へ
折る
Swivel to the
right.

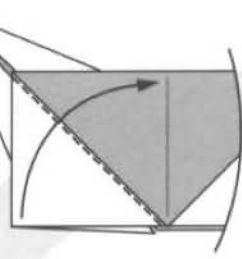

13

13
内側をひろげて
つぶすように折る
Form a small bird base
(the right side only).

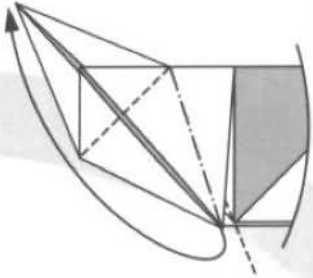

11

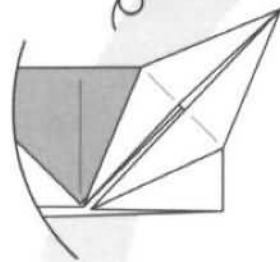

14
カドを下に折る
Fold down the
top layers.

14

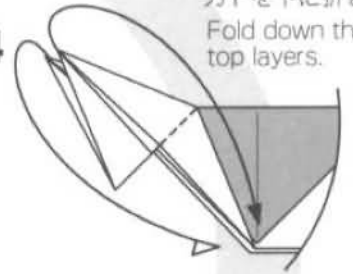

10

10
内側をひろげて
つぶすように折る
Form a small
bird base.

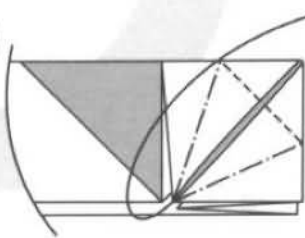

15
重なっている部分を
はがすようにして
裏返す
Detach the top
layer and turn
it over.

15

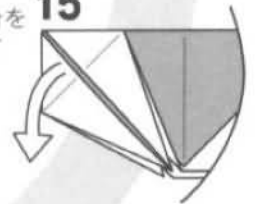

17
重なっている部分を
はがすようにして
裏返す
Detach the top layer
and turn it over. ☆

17

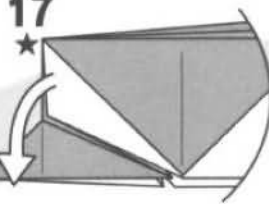

16

16
カドを反対側へ折る
Swivel to the right.

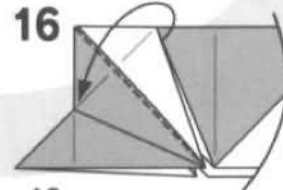

18 ☆

18
途中の図
Open the top layer
while detaching.

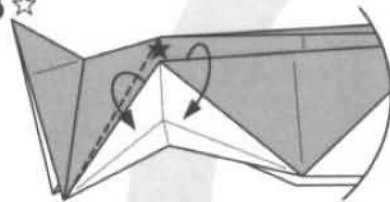

19

19
図のような折り筋で
折りまとめる
Fold up using the
precrease line.

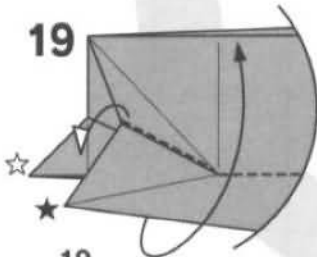

22

22
縁を折り筋に合わせて
折り筋をつける
Precrease the left
edge to the diagonal.

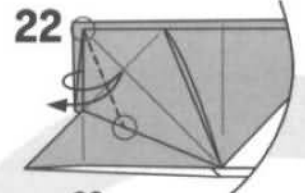

20 ☆

20
反対側も16~19と同じ
Repeat 16~19 on the back.

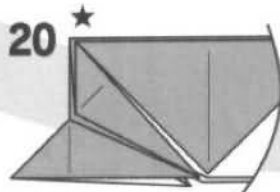

21

21
カドを反対側へ折る
Swivel to the right.

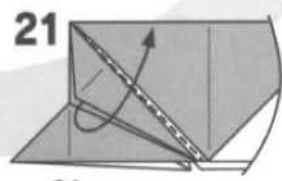

32 カド3つ
Three corners.

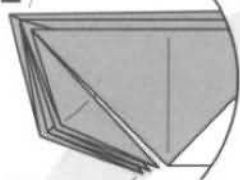

カド3つ
Three corners.

31

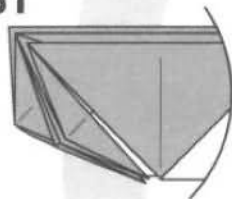

31 反対側も
27~30と同じ
Repeat 27~30
on the back.

30

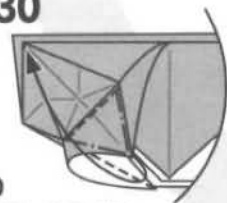

30 内側をひろげて
つぶすように折る
A bird-base-like fold.

33

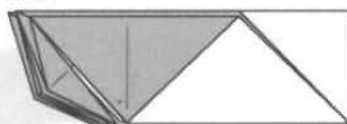

33 反対側も7~31と同じ
Repeat 7~31 on
the right.

34

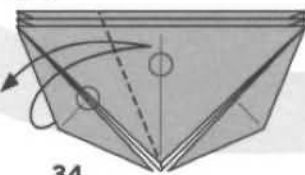

34 ○と○を合わせて
折り筋をつける
Precrease so that the
circled lines will align
with each other.

29

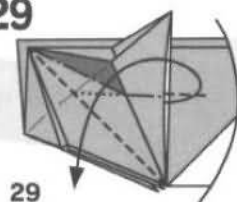

29 内側をひろげて
■の部分をつぶすように折る
Open and squash
the darkened part.

28

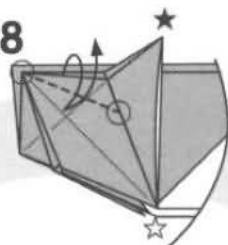

28 縁を折り筋に合わせて
折り筋をつける
Precrease the right
edge to the diagonal.

折り筋をつけない
ように曲げるだけ
Do not fold the
darkened line.
Just bend along it.

27

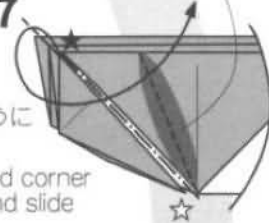

27 カドをつまむように
折る
Pinch the starred corner
(the top one) and slide
it to the right.

23

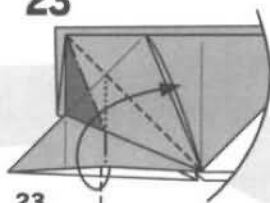

23 側をひろげて■の部分をつぶすように折る
Open and squash
the darkened part.

24

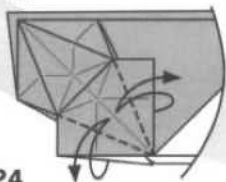

24 縁を折り筋に合わせて
折り筋をつける
Precrease the lower
edge to the diagonal.

25

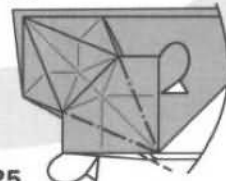

25 カドを内側に折る
Inside reverse folds.

26

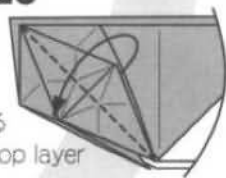

26 上の1枚を
反対側に折る
Swivel the top layer
to the left.

35
内側をひろげて
つぶすように折る
Swivel open and
squash.

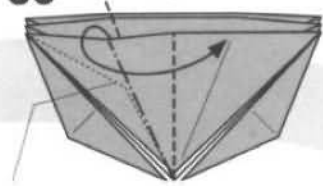

内側のカドは手前に
くるように折る
The hidden corner will
still be hidden under
the top layer.

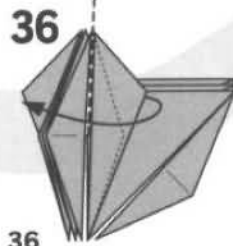

36
カドを反対側に折る
Swivel to the left.

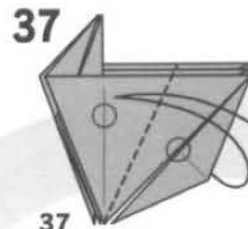

37
反対側も34~36と同じ
Repeat 34~36
on the right.

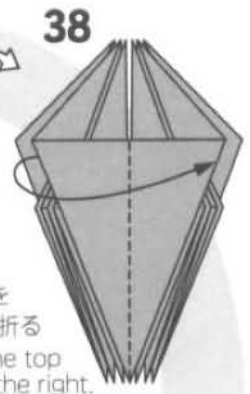

38
上の1枚を
反対側に折る
Swivel the top
layer to the right.

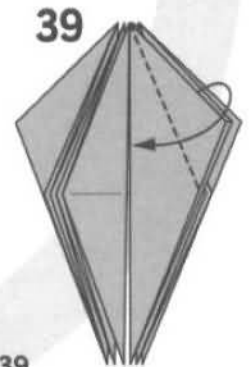

39
縦を中心に合わせて折る
Fold the top right edge
to the center diagonal.
Fold tightly.

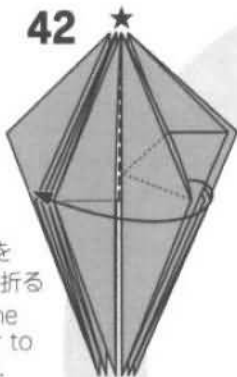

42
上の1枚を
反対側に折る
Swivel the
top layer to
the right.

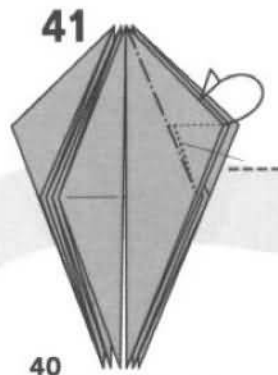

41
カドを内側に折る
Tuck the corner
inside.

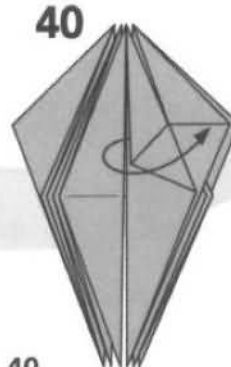

40
折り筋をつけてから戻す
Unfold.



43
内側のカドを
つまんで
ずらすように折る
Pinch the inner
corner and slide
it to the left.

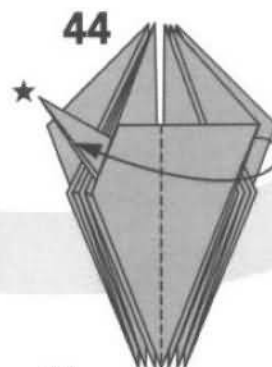

44
反対側も38~43と同じ
Repeat 38~43 on the right.

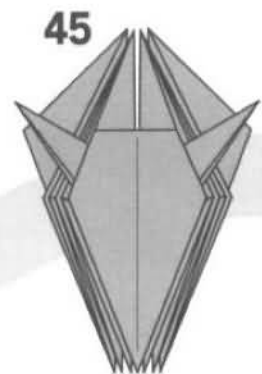

54
すぐ上のカドを
中わり折り
Inside reverse fold
the corners immediately
above the legs folded
in 52.

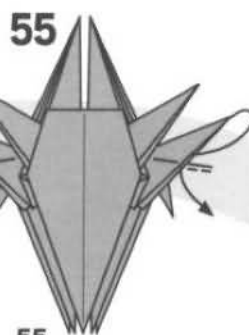
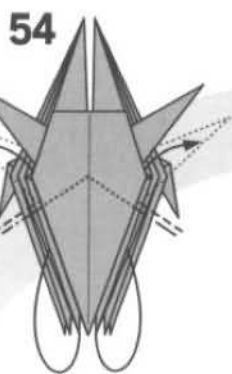

55
中わり折り
Inside reverse
folds.



56
カドを内側に折る
Tuck the corners
inside.

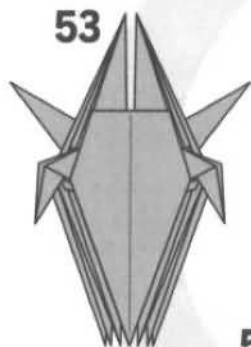

53

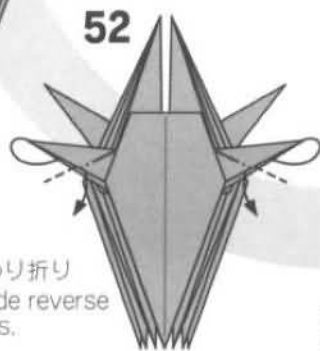

52
中わり折り
Inside reverse
folds.

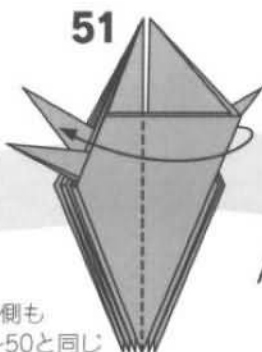

51
反対側も
46~50と同じ
Repeat 46~50
on the right.



50
内側のカドを
つまんで
ずらすように折る
Pinch and slide
the inner corner
to the left.

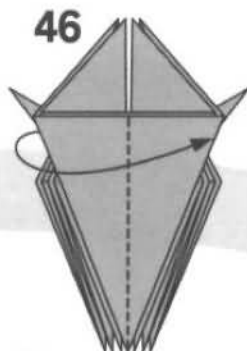

46
上の1枚を反対側に折る
Swivel the top layer.

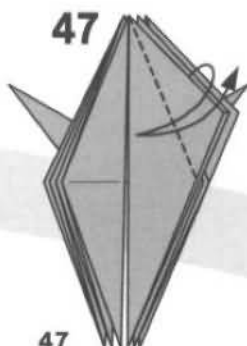

47
縁を中心に合わせて
折り筋をつける
Precrease the top
edge to the center
diagonal.

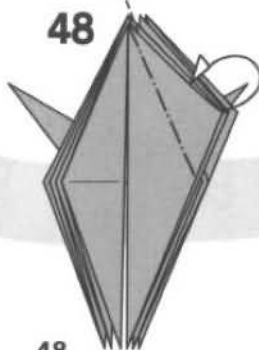

48
カドを内側に折る
Tuck the corner
inside.

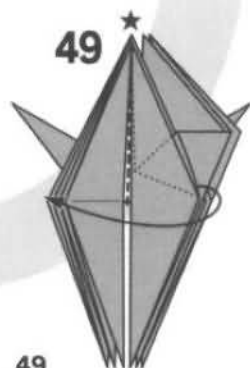

49
上の1枚を反対側に折る
Swivel the top layer
to the left.

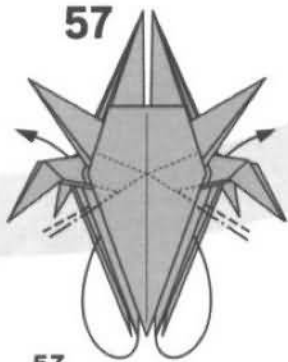

57
他の4ヶ所も同じに折る
Do the same fold to
the remaining four
inner corners.

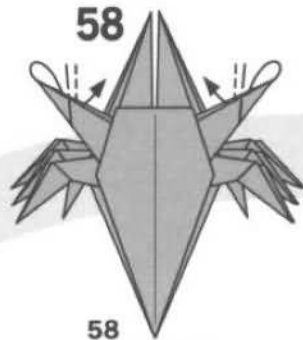

58
中わり折り
Inside reverse
folds.

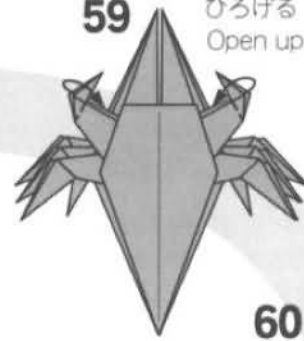

59
ハサミの部分
をひろげる
Open up the claws.

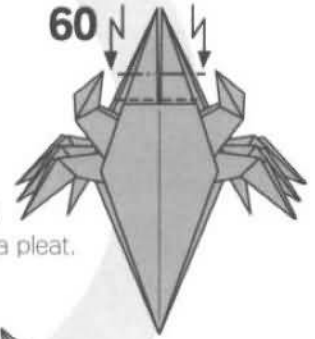

60
段折り
Form a pleat.

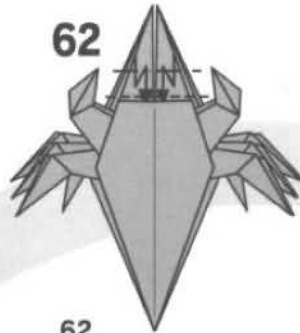

62
つけた折り筋で
すき間に折り込む
Tuck the top corner
inside using the existing
crease lines.

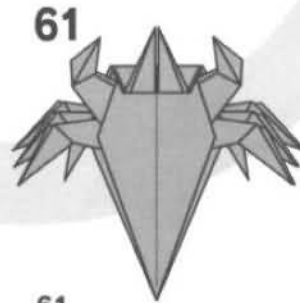

61
しっかりと折り筋を
つけてから60の形に戻す
Unfold to 60 after folding
tightly.



63
カドを上
に折る
Fold up to the
top corner.

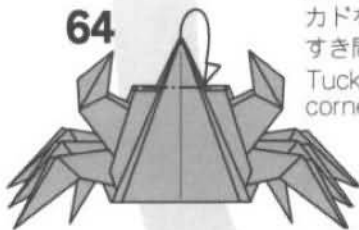

64
カドを後ろへ折って
すき間に差し込む
Tuck the top
corner inside.



できあがり
Model Completed



65
カドをねじるようにして
目をつくる
Shape the eyes.

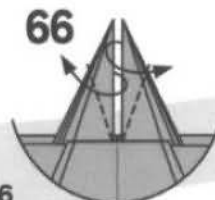

66
図のようにカドを斜めに折る
Valley folds.



シャチ

Grampus

シャチの特徴は何と言っても黒白のコントラストです。図鑑と逐一比べると随分違うのですが、水中から飛び上がったシルエットも比較的上手く決まって、私としては満足できる“見立て”を得たと思っています。

Although details are different from the real killer whale, this model is a good example of an inside out model. It was possible because my first diagnosis of the target was very good.

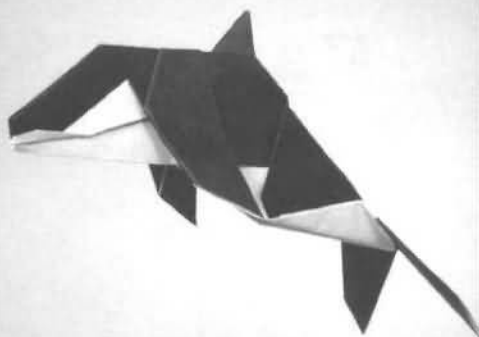

Created 1983 Paper 不切正方一枚折り: 1 piece

P. 8 [風船基本形]からはじめる
Start with [Water Bomb Base] (P. 8)

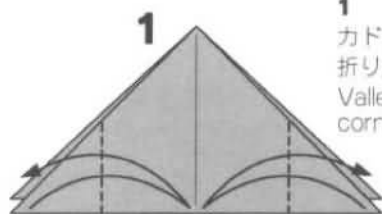

1
カドを中心に合わせて
折り筋をつける
Valley fold the side
corners to the center.

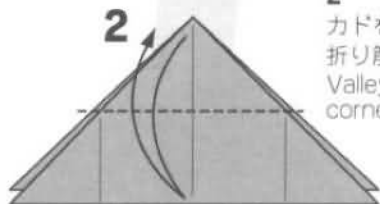

2
カドを縁に合わせて
折り筋をつける
Valley fold the top
corner to the bottom.

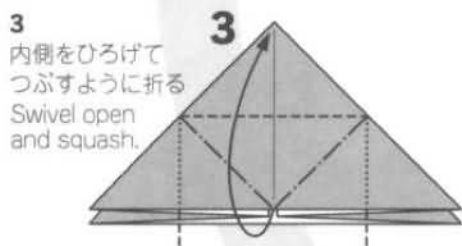

3
内側をひろげて
つぶすように折る
Swivel open
and squash.

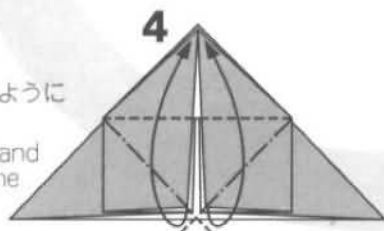

4
カドをつまむように
上に折る
Swivel open and
squash on the
two sides.

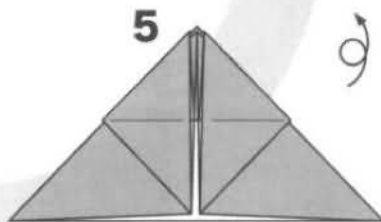

5

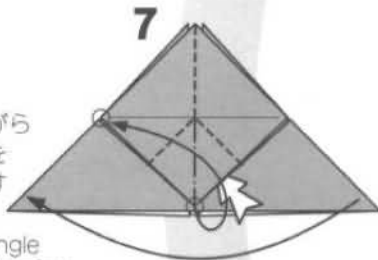

7
半分に折りながら
○と○のカドを
合わせてつぶす
ように折る
Close the triangle
in half, while forming
an inside reverse
fold on the small
triangular flap...

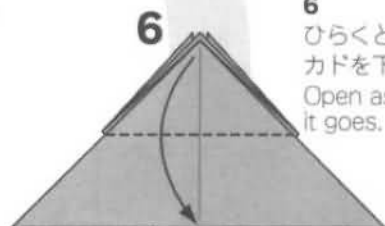

6
ひらくところで
カドを下に折る
Open as far as
it goes.

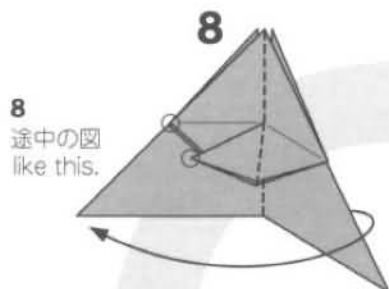

8
途中の図
like this.

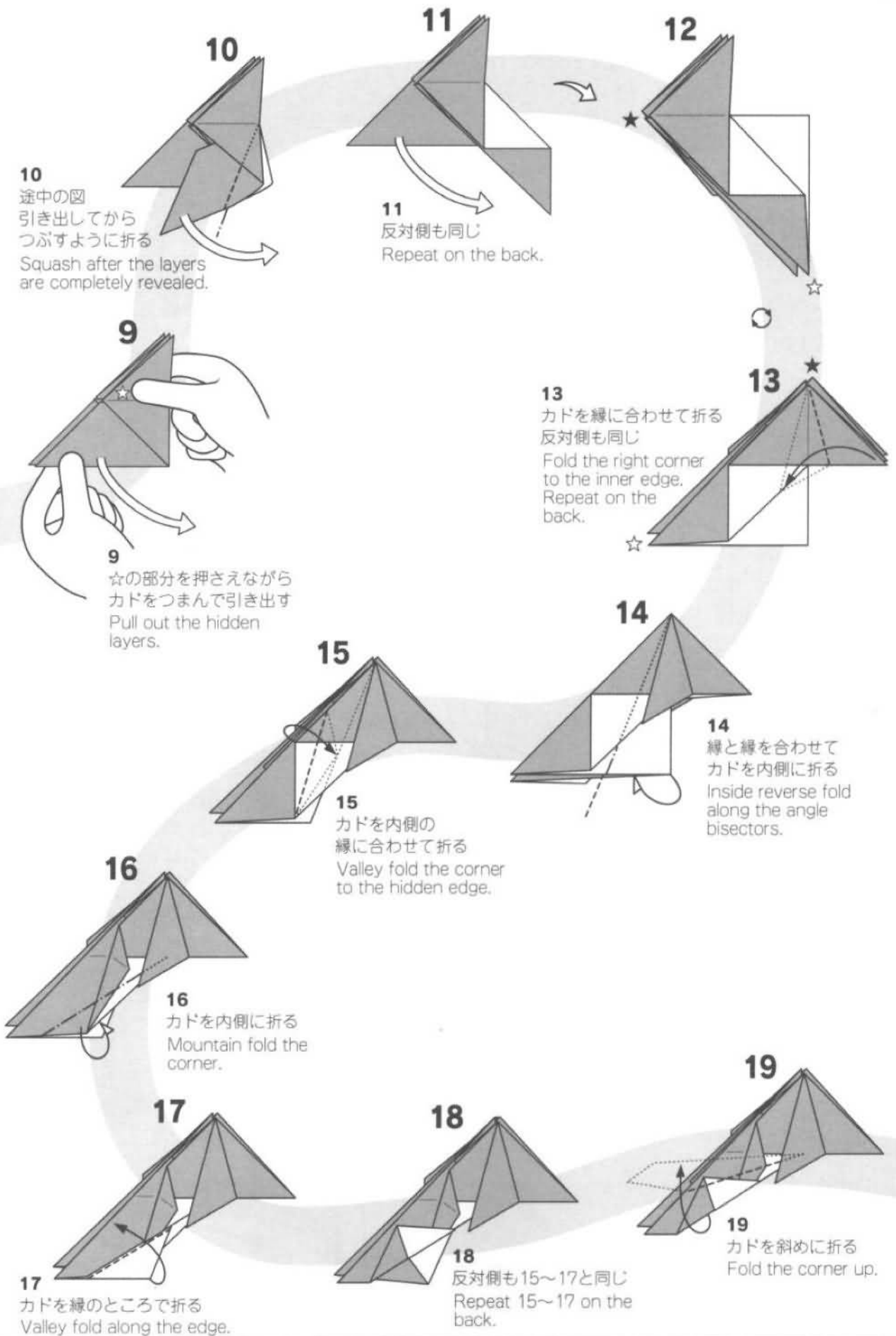

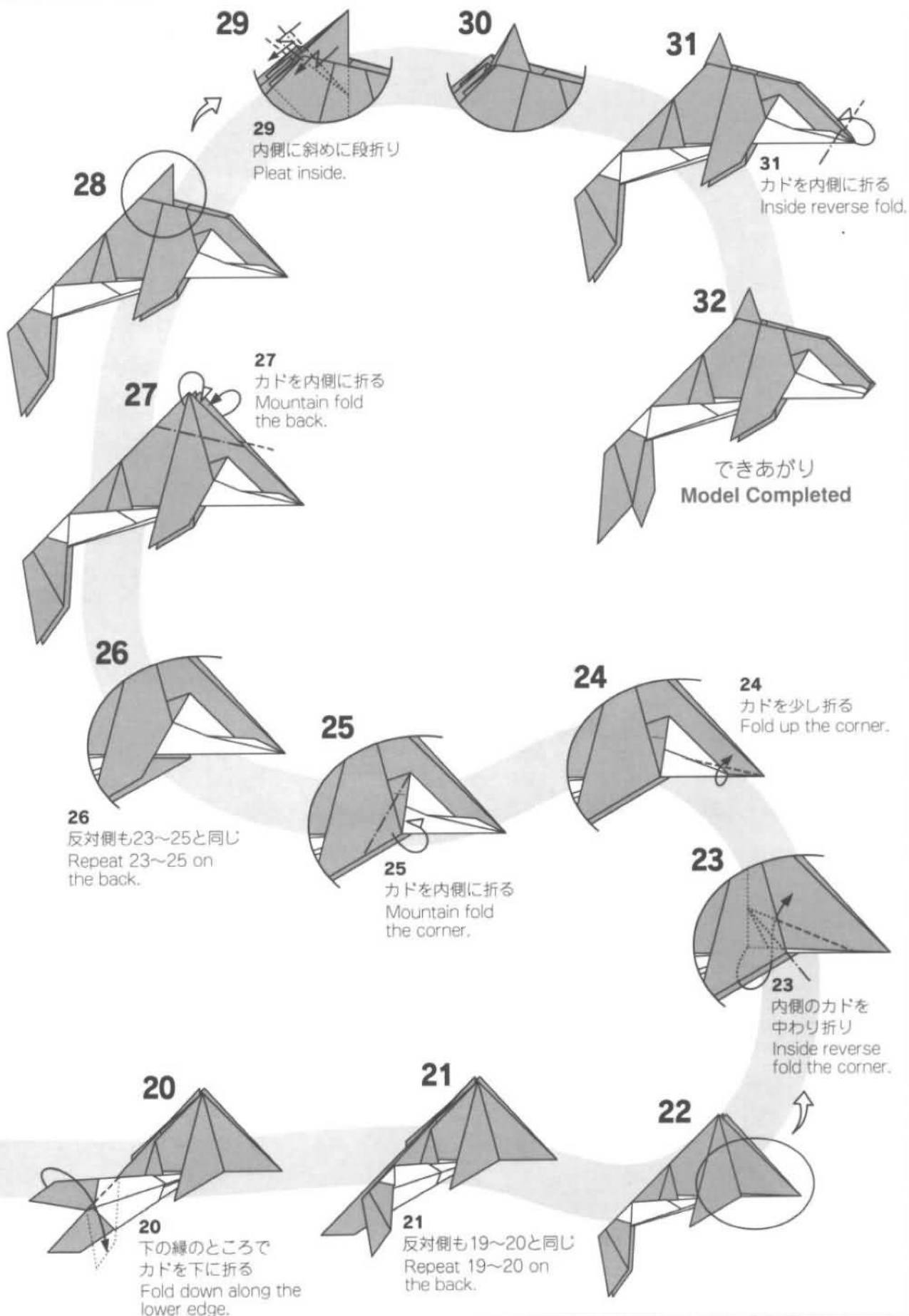

スペースシャトル

Space Shuttle

最後のコックピットの折りと鼻先のデザインがはじめにあって、やや強引に形を作っていきます。きれいに折るとスペースシャトルの下から見たフラットな感じも出せるのがちょっとした幸運です。

The whole model is based on the idea about the designs of the cockpit and the nose, and all previous folds converges into them. You can see the plane appearance of the bottom view of the shuttle.

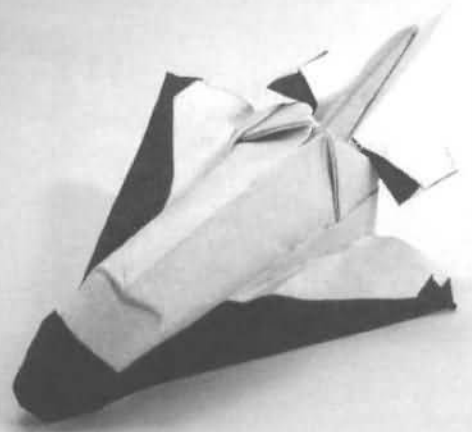

Created 1996 Paper 不切正方一枚折り: 1 piece

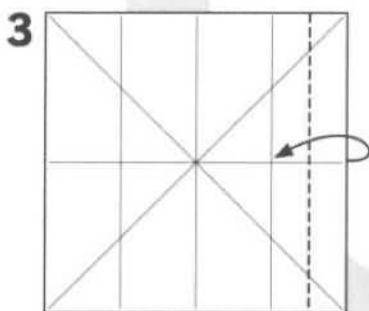
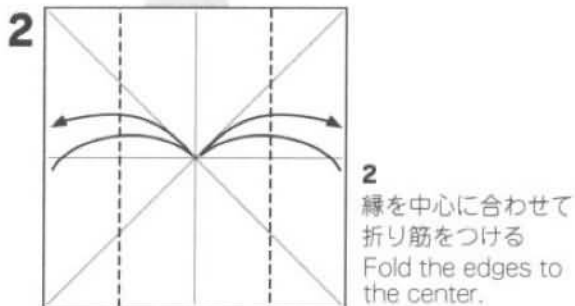
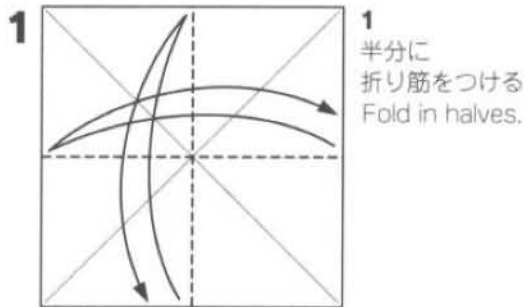

3 縁を折り筋に合わせて折る
Fold the right edge to the closest crease line made in 2.

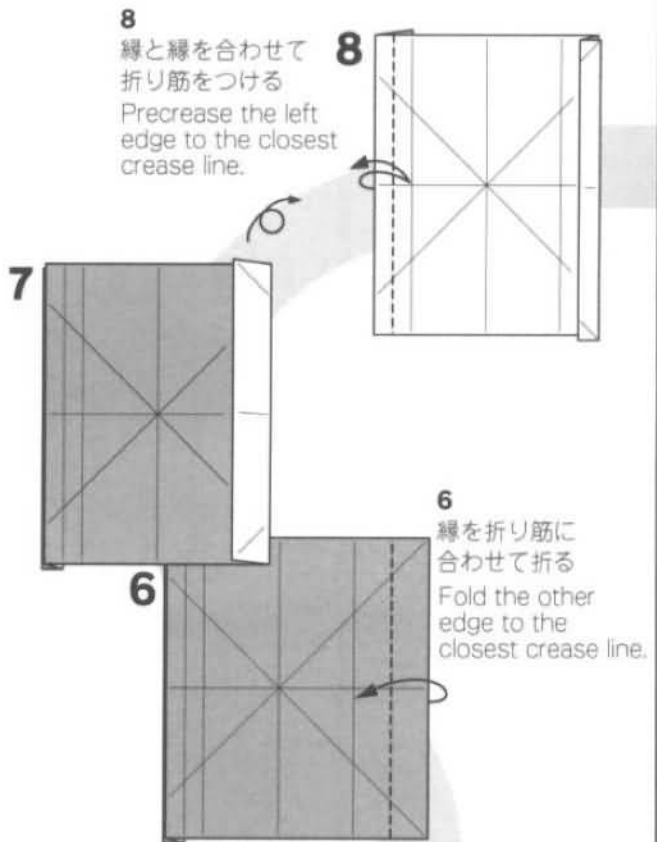
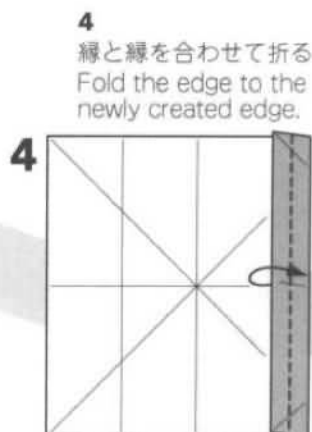

3 宇宙/スペースシャトル

9
下のカドを反対側に戻す
Unfold to 10.

10
縁を折り筋に合わせて折る
Fold along the first crease line.

11
後ろへ半分に折る
Mountain fold in half.

12
縁と折り筋を合わせて折る
折り筋をつける
Fold the top edge to the second crease line from the left.
Unfold.

13
縁と折り筋を合わせて折る
折り筋をつける
Fold the top edge to the first crease line from the right.
Unfold.

14
内側をひろげてつぶすように折る
Open and squash.

15
つけた折り筋を使って○の部分を上のカドに合わせて折る
内側をひろげて折る
Swivel up and squash.

16
ついている折り筋でカドをつまんで折りまとめる
Pinch the top corners and rotate the sides...

17
途中の図 like this.
Close the area with the top corners.

18
左右のカドを合わせるようにまとめる
Close the opening.

19
縁を折り筋に合わせて折り筋をつける
Fold the right edge to the center line.

20
内側をひろげてつぶすように折る
Open and squash.



29
反対側も
24~28と同じ
Repeat 24~28
on the back.

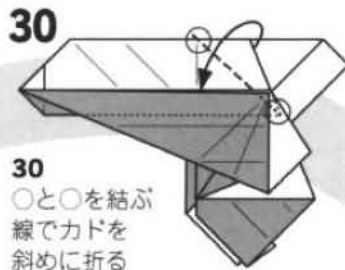

30
○と○を結ぶ
線でカドを
斜めに折る
Valley fold along the line
connecting the circled
intersections.

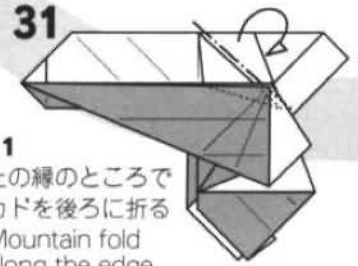

31
上の縁のところ
カドを後ろに折る
Mountain fold
along the edge.

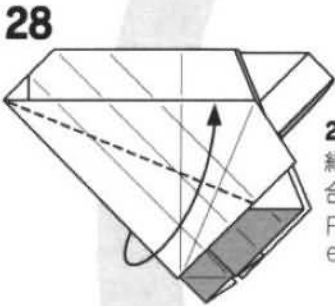

28
縁と縁を
合わせて折る
Fold edge to
edge.

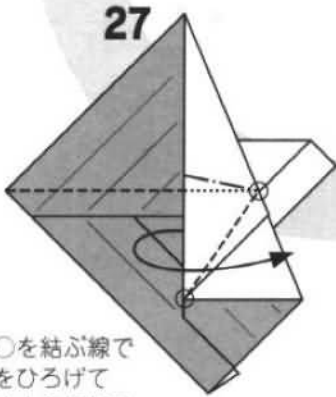

27
○と○を結ぶ線
で内側をひろげて
つぶすように折る
Swivel along the line
connecting the
circled intersections
and squash.

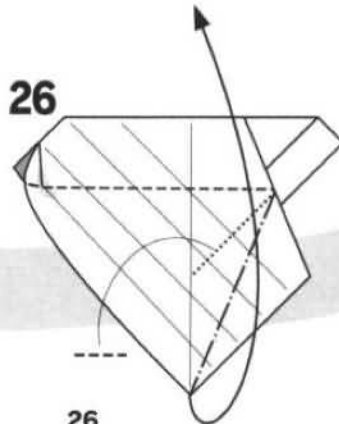

26
内側をひろげて
つぶすように折る
Swivel up and squash.

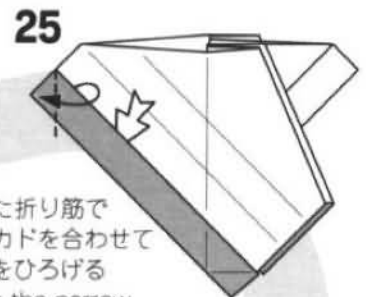

25
つけた折り筋で
縁とカドを合わせて
内側をひろげる
Open the narrow
pocket using the
crease line in 24.

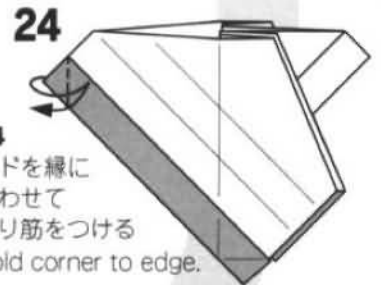

24
カドを縁に
合わせて
折り筋をつける
Fold corner to edge.

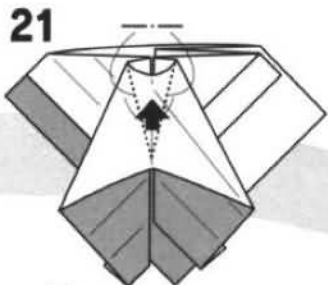

21
途中の図
Spread the excess
layer and squash.

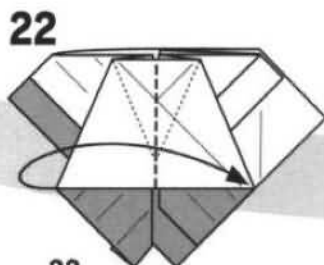

22
カドを反対側に折る
Swivel to the right.

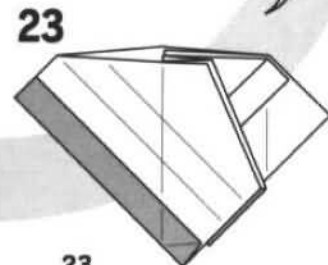

23
反対側も19~22と同じ
Repeat 19~22 on the right.

32

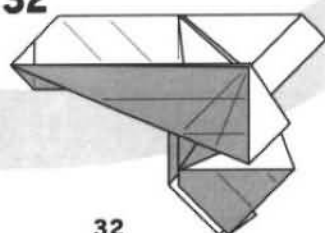

32
反対側も30~31と同じ
Repeat 30~31 on
the back.

33

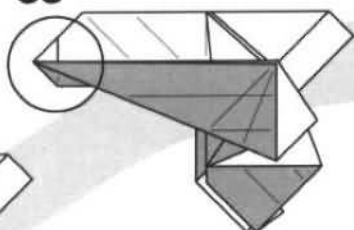

34

34
カドを縁に
合わせて折る
Fold the left
corner to the
inner edge.

35

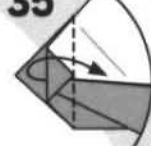

35
開くところで
折る
Open as far as
possible.

36

36
反対側も34~
35と同じ
Repeat 34~35
on the back.

36

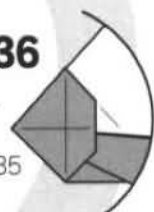

38

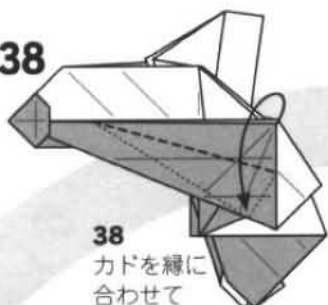

38
カドを縁に
合わせて
斜めに折る
Fold the colored
corner to the
lower edge.

37

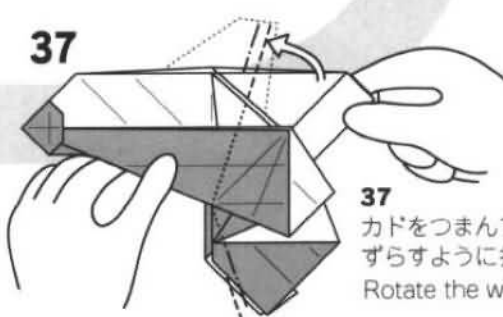

37
カドをつまんで
ずらすように折る
Rotate the wing.

39



39
カドを後ろへ折る
Mountain fold
the corner.

40

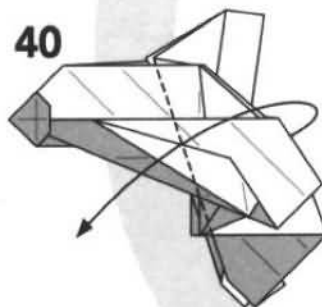

40
開くところでカドを折る
Swivel where it opens.

42

42
途中の図
Also form an inside
reverse fold on the
top edge.

42

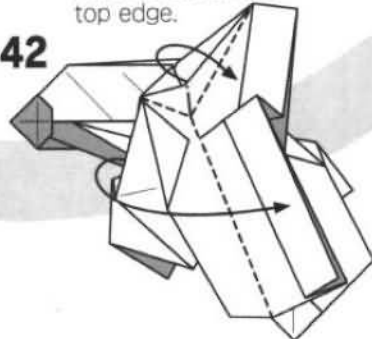

43

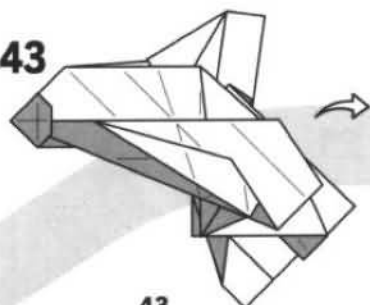

43
反対側も38~42と同じ
Repeat 38~42
on the back.

41

41
図のような
折り筋で
段折りしながら
それぞれ縁と縁を
合わせて折る
Form a pleat while
closing where
indicated.

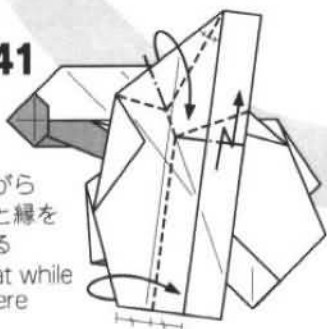

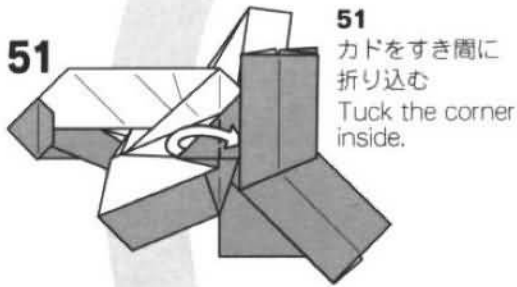
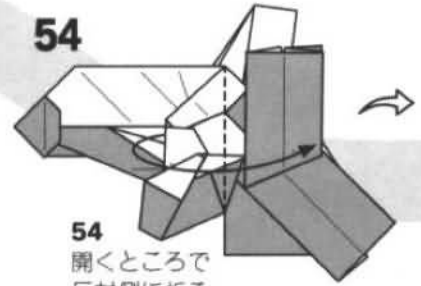
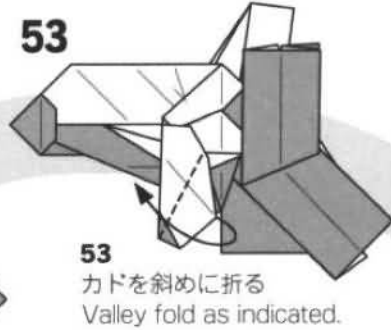
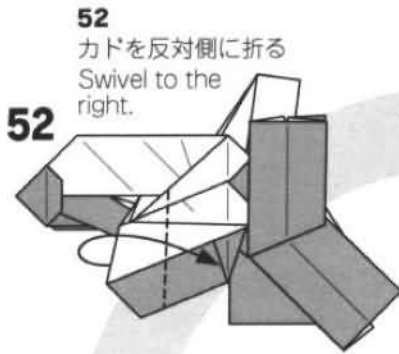

54
開くところで反対側に折る
Swivel to the right where it opens.

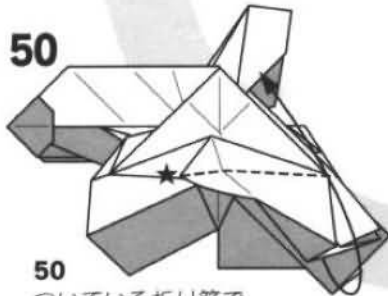

50
ついている折り筋でつられて持ち上がる部分を上に折る
Swivel up along the precrease line.

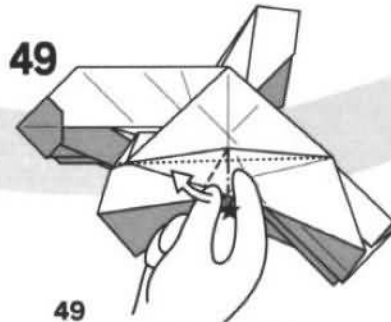

49
48でカドになった部分をついている折り筋で上に折る
Swivel up and close to the left.

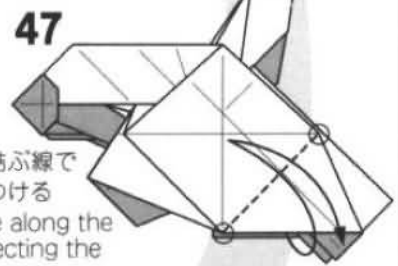
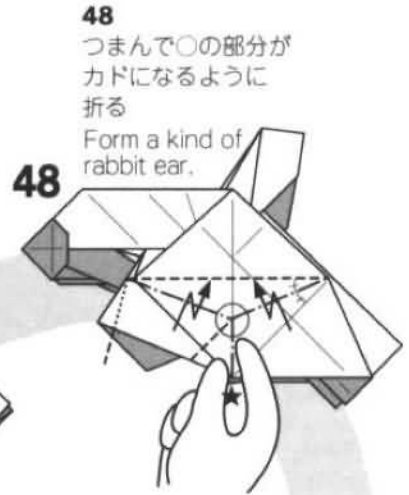

47
○と○を結ぶ線で折り筋をつける
Precrease along the line connecting the circled corners.

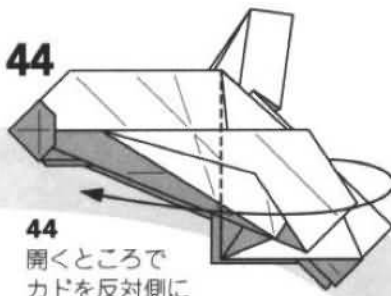

44
開くところでカドを反対側に折る
Swivel where the wing opens.

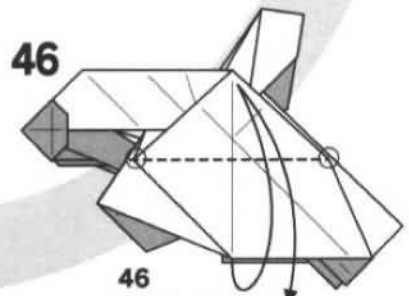

46
カドとカドを合わせて折り筋をつける
Precrease along the line connecting the circled corners.

55

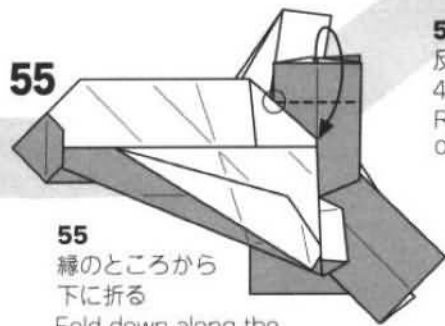

55
縁のところから
下に折る
Fold down along the
line starting from the
intersection.

56

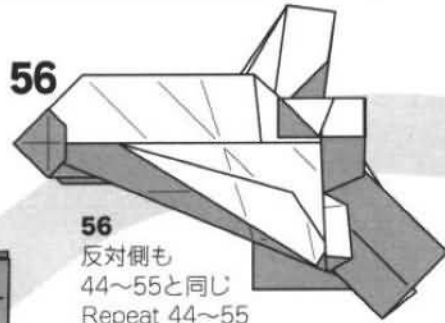

56
反対側も
44~55と同じ
Repeat 44~55
on the back.

57

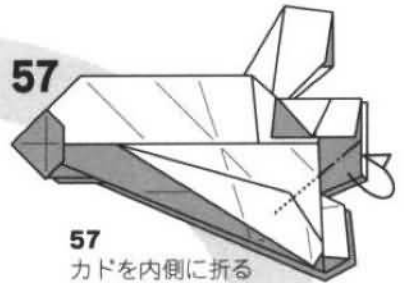

57
カドを内側に折る
反対側も同じ
Mountain fold the tail.
Repeat on the back.

58

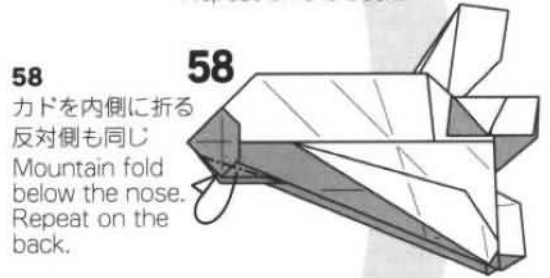

58
カドを内側に折る
反対側も同じ
Mountain fold
below the nose.
Repeat on the
back.

58

60

上のすき間の部分を
糊付けする
Glue the top portion
of the back.

60



59

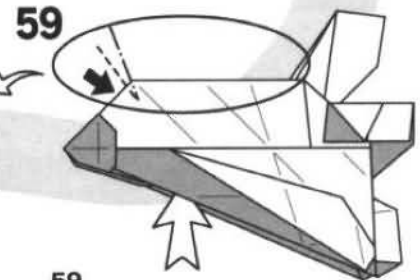

59
黒矢印の部分を押し込みながら
内側をひろげて立体にする
Push on the back and shape
the body.

61

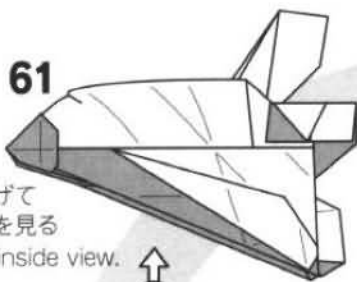

61
ひろげて
内側を見る
The inside view.

62

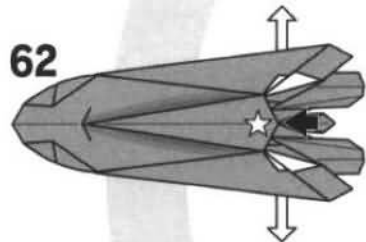

62
翼をひろげながら
☆の部分をひろげて
つぶすように折る
Open the wings and
squash the starred part.

63

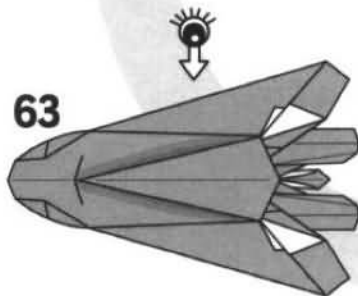

64

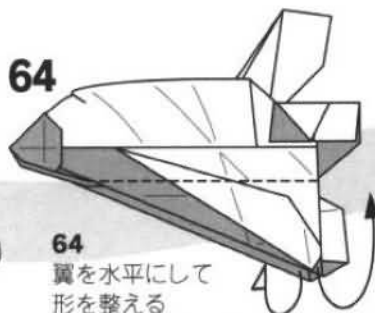

64
翼を水平にして
形を整える
Open the wings level and
shape them to the taste.

65

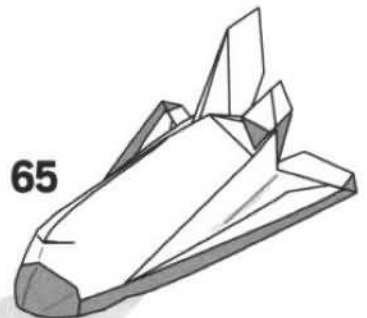

できあがり
Model Completed

天体望遠鏡

Telescope

反射望遠鏡です。赤道儀や照準器など小物をパーツで作る複合作ですが、作例が見あたらないので一興といったところでしょうか。星座を機つか作った際に小物として考えてみたものです。

This is a modular reflecting telescope, which as far as I know can't be seen anywhere else. You should fold it with Constellations.

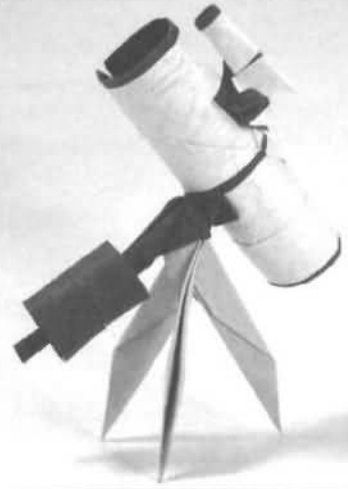

Created 1989 Paper 複合作品・4枚: 4 pieces

[本体] Body

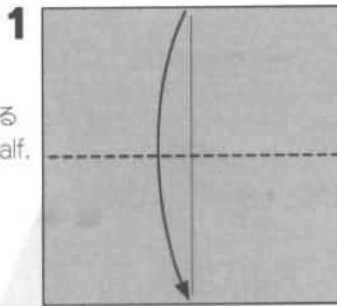

1
半分に折る
Fold in half.

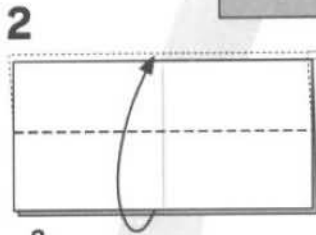

縁からほんの
少し出す
Note that the edges
do not align with
each other.

2
縁から少し出るように折る
Fold up.

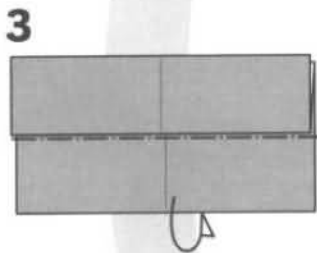

3
上の縁の
ところで
後ろへ折る
Mountain
fold along
the edge.

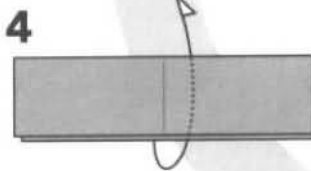

4
下の縁を
上に折る
Swivel up the
lower layer.

5
中心から2の幅と
同じに離して折る
Open and squash.
Leave the same
amount of width as
in 2 in the center.

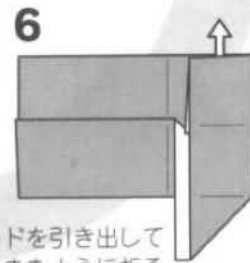
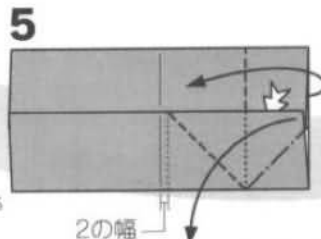

6
カドを引き出して
つまむように折る
Pull out the hidden layers.

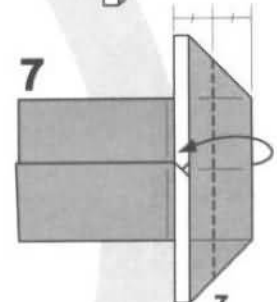

7
縁と縁を
合わせて折る
Fold edge to
edge.



9
縁と縁を合わせて
つぶすように折る
Squash the top
and the bottom.

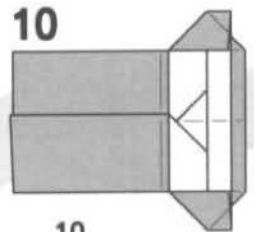

10
反対側も5~9と同じ
Repeat 5~9 on
the back.

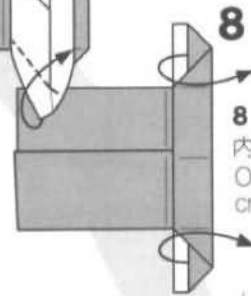

8
内側をひろげる
Open along the
crease line in 7.

[紙の比率] Paper Size

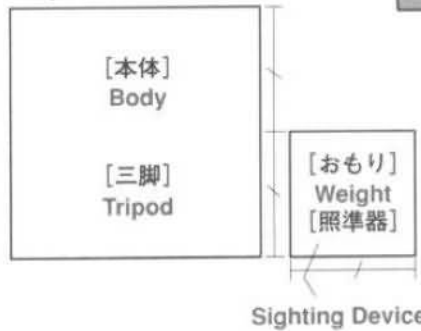

3 宇宙/天体望遠鏡

12
カドを縁の
ところで折る
Fold the
corners along
the edges.

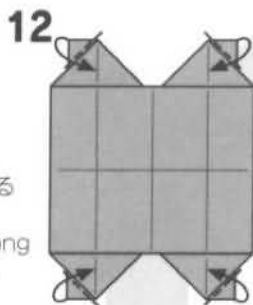

13
カドを縁に沿って折る
Fold the corners
along the edges.

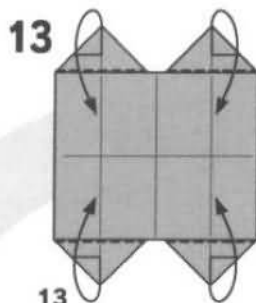

14
下の2つだけ戻す
Unfold the bottom
corners.

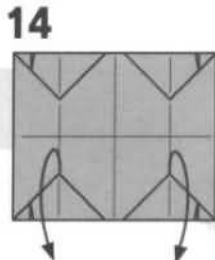

15
縁と縁を合わせて
折り筋をつける
Fold edge to edge.

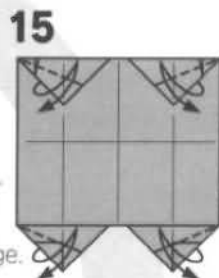

16
筒状の物で
しっかりと
丸みをつける
Roll it with
something
like a pen.

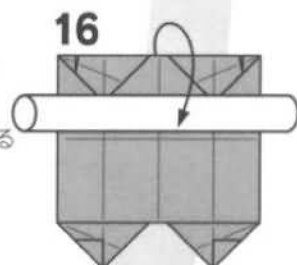

17
ついている折り筋で
カドを起こすようにする
Swivel the bottom
corners using the
precrease lines.

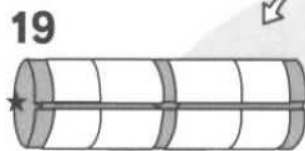
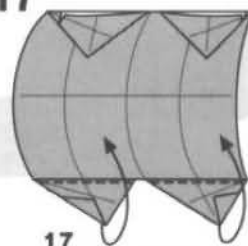

18
丸めて筒状にしなが
ら☆のカドを★のす
き間に
差し込む
Roll and tuck the
bottom
corners into the
top
pockets.



20
○の部分の
内側を見る
The inside view.

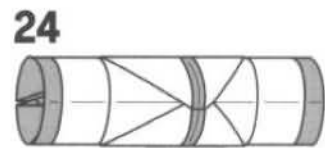
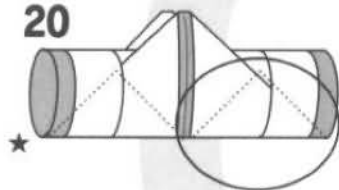

[本体]のできあがり
[Body] Completed

21
内側を見た図
ついている折り筋で
内側のカドを
折って止める
Fold along the precrease
line and lock it.

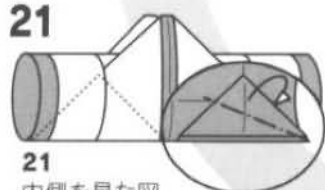

22
反対側も同じ
Repeat on
the left.

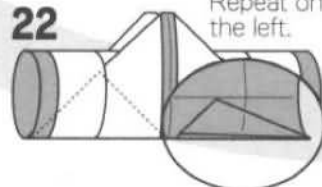

23
筒の部分に沿って
のりづけ
Glue along the body.

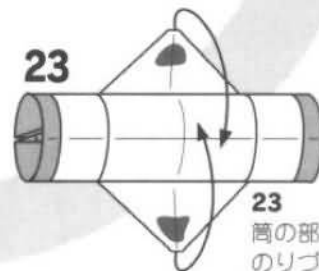

[おもり]
Weight

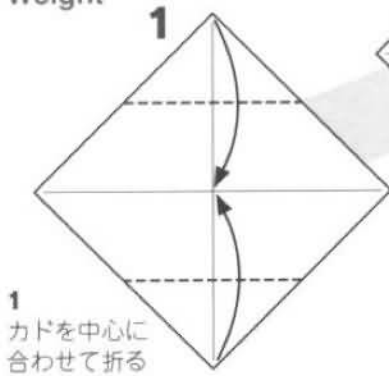

1
カドを中心に
合わせて折る
Fold the two
corners to
the center.

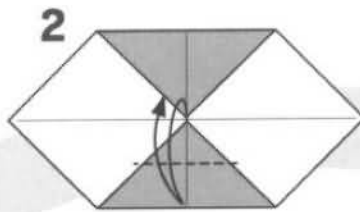

2
カドと縁を合わせて
折り筋をつける
Fold the bottom
corner to the bottom
edge and unfold.

3
折り筋を縁に合わせて折る
Fold the precrease line
to the bottom edge.

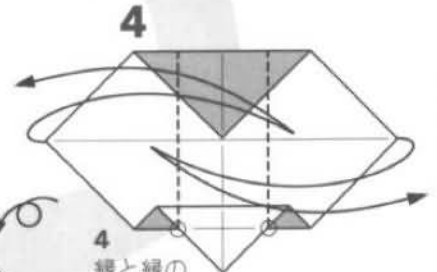
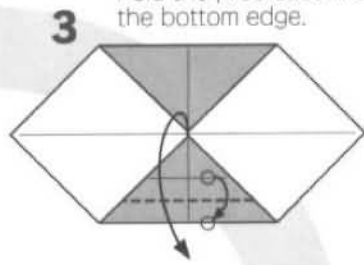

4
縁と縁の
交点のところ
で折り筋をつける
Precrease vertically
starting from the bottom
intersections.

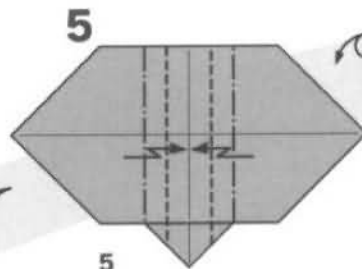

5
4でつけた折り筋を
中心に合わせて段折り
Form pleats.

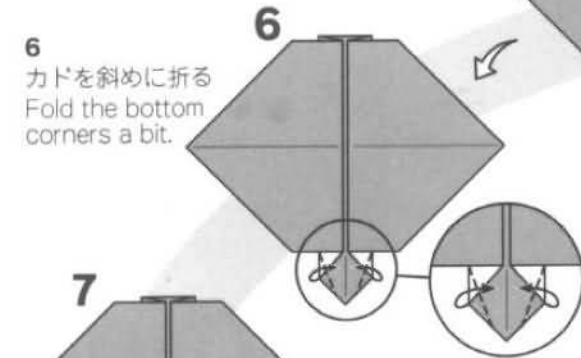

6
カドを斜めに折る
Fold the bottom
corners a bit.

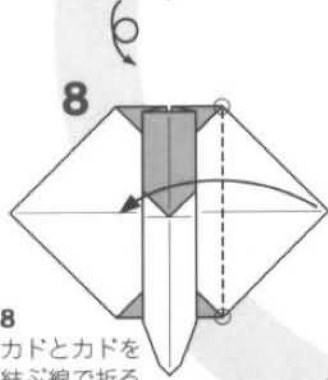
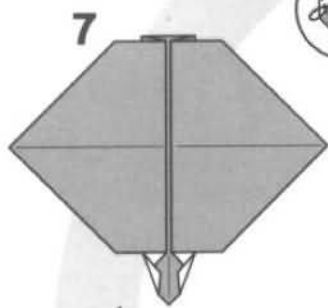

8
カドとカドを
結ぶ線で折る
Fold along the line
connecting the
corners.



9
縁と縁を
合わせて
折り筋をつける
Precrease edge to edge.

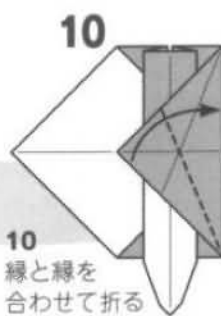

10
縁と縁を
合わせて折る
Fold edge to edge.

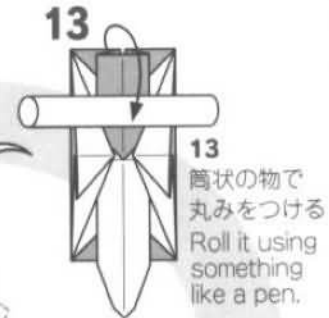
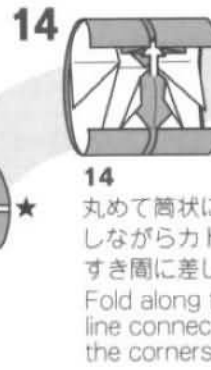

13
筒状の物で
丸みをつける
Roll it using
something
like a pen.

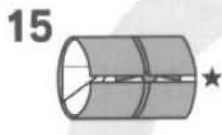

14
丸めて筒状に
しながらカドを
すき間に差し込む
Fold along the
line connecting
the corners.

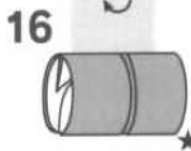

16
[おもり]の
できあがり
[Weight] Completed

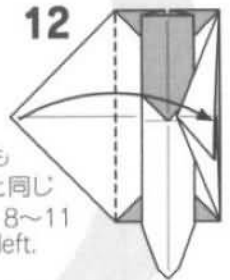

12
反対側も
8~11と同じ
Repeat 8~11
on the left.



11
カドをつまむ
ように折る
Swivel down
and squash.

3 宇宙/天体望遠鏡

[三脚] P. 8 [鶴の基本形] から始める
 Tripod Start with [Bird Base] (P. 8)

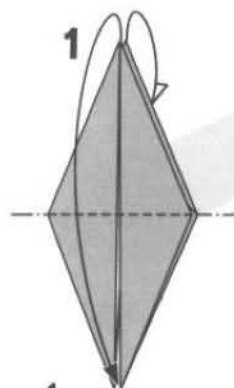

1
 カドを下に折る
 Swivel down.

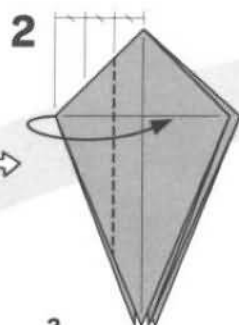

2
 1/3のところ
 カドを反対側に折る
 Swivel to the right at
 a third from the center.

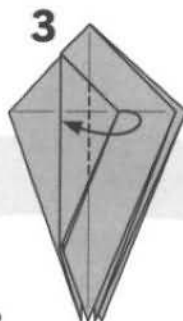

3
 同じ幅で反対側に折る
 Swivel to the left along
 the center line.

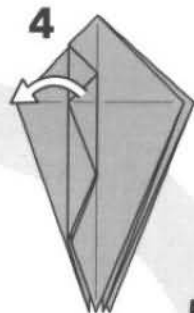

4
 折り筋を
 つけて戻す
 Unfold.

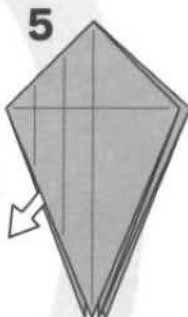

5
 内側の紙を
 引き出す
 Pull out the
 inner layers.

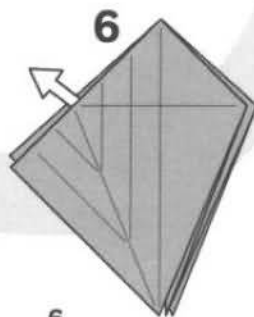

6
 内側の紙を引き出す
 Pull out the inner layer.

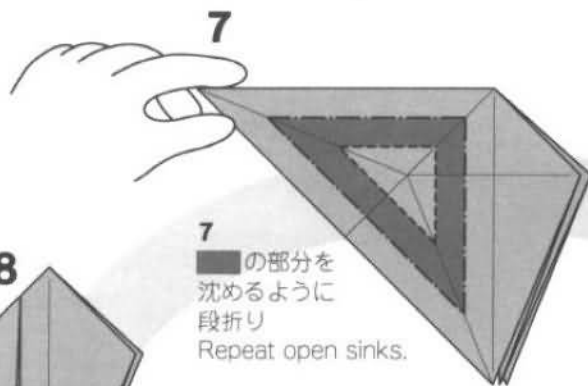

7
 ■の部分
 を沈めるように
 段折り
 Repeat open sinks.

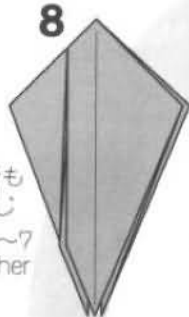

8
 他の3ヶ所も
 2~7と同じ
 Repeat 2~7
 on the other
 three
 corners.



9
 カドとカドを
 結ぶ線で
 折り筋をつける
 Fold along the
 line connecting
 the corners.

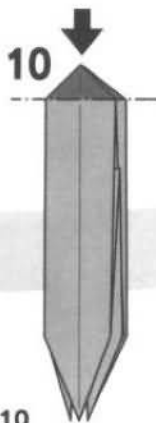

10
 ■の部分
 を沈め折り (open sink)
 Open sink.

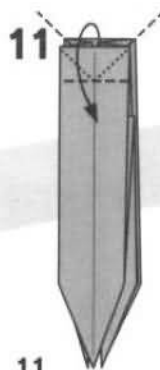

11
 内側をひろげて
 つぶすように折る
 Swivel down.

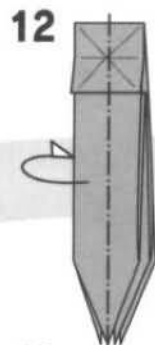

12
 後ろへ半分に折る
 Mountain fold in half.

20



20
ひろげたまま
かるく戻して
内側を見る
See the back side.

21

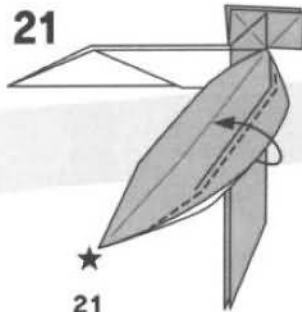

21
19で引き出した部分
をかぶせるように折る
Wrap the pulled-out
layer around.

22

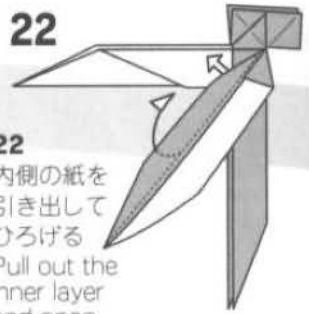

22
内側の紙を
引き出して
ひろげる
Pull out the
inner layer
and open.

19

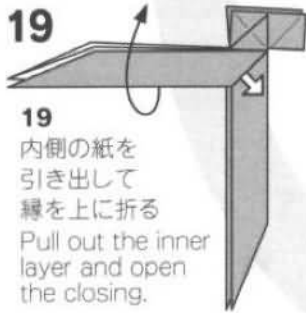

19
内側の紙を
引き出して
縁を上折る
Pull out the inner
layer and open
the closing.

18



18
カドとカドを
合わせて
斜めに折る
Fold corner
to corner.

17



17
反対側も
15~16と同じ
Repeat 15~16
on the back.

16



16
裏返した部分を
すぐ後ろの
すき間に折り込む
Tuck the pulled-out
layer inside.

13

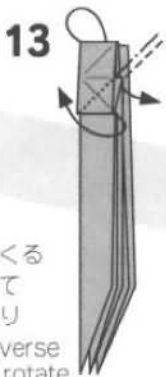

13
カドをめくる
ようにして
中わり折り
Inside reverse
fold and rotate
the top rectangle.

14

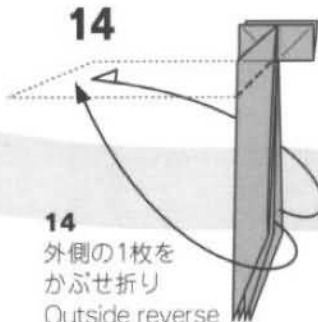

14
外側の1枚を
かぶせ折り
Outside reverse
the top layers.

15

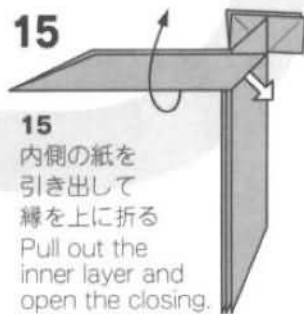

15
内側の紙を
引き出して
縁を上折る
Pull out the
inner layer and
open the closing.

23

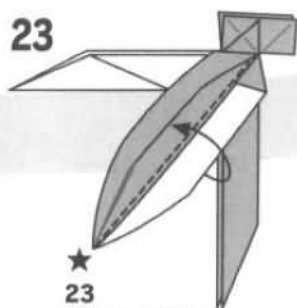

★
23
このまま20の
形まで戻す
Back to the
front side.

24

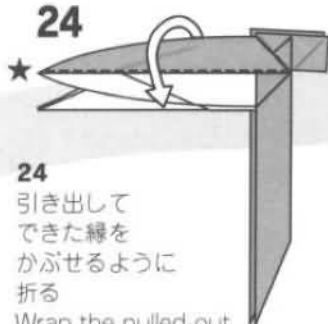

★
24
引き出して
できた線を
かぶせるように
折る
Wrap the pulled-out
layer around.

25



25
反対側も
18~24と同じ
Repeat 18~24
on the back.

26

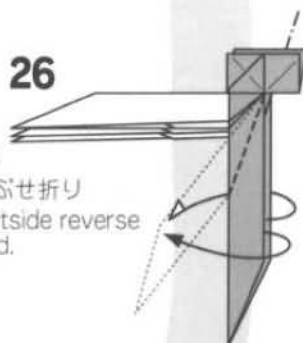

26
かぶせ折り
Outside reverse
fold.

28

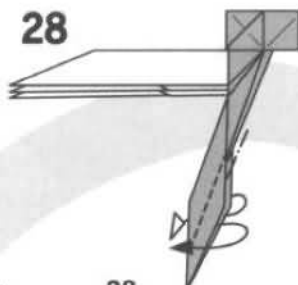

28
かぶせ折り
Outside reverse
fold.

27

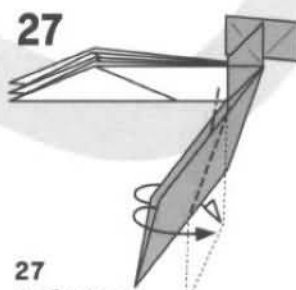

27
かぶせ折り
Outside reverse
fold.

29

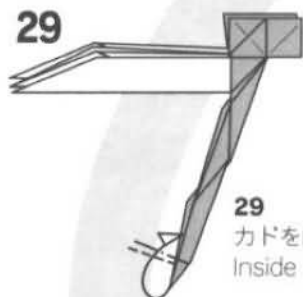

29
カドを内側に折る
Inside reverse
fold.

30

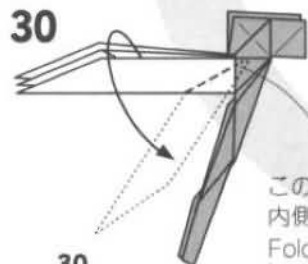

30
カドを下に折る
反対側も同じ
Fold down the corner.
Repeat on the back.

この部分は
内側だけ折る
Fold only the inner
layers here.

31

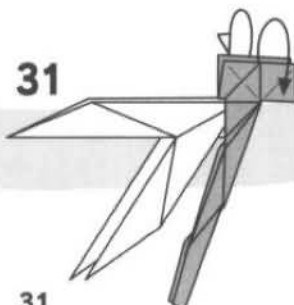

31
ひろげて平らにする
Spread the rectangular
closing.

32

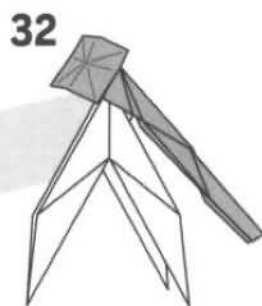

[三脚]のできあがり
[Tripod] Completed

[照準器] Sighting Device

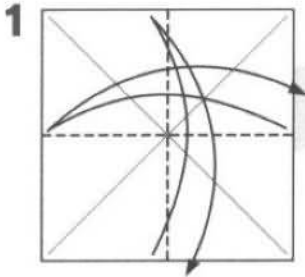

1 縦横半分に折り筋をつける
Fold in halves.

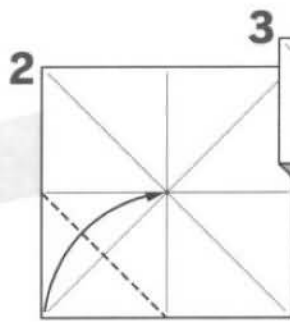

2 カドを中心に合わせて折る
Fold the corner to the center.

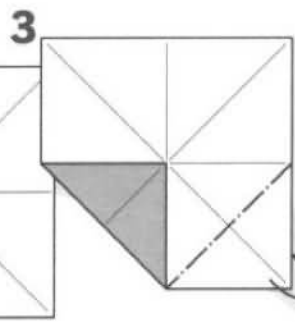

3 カドを中心に合わせて後ろへ折る
Mountain fold the corner to the center.

4 縁を少し折る
Fold along the edge.

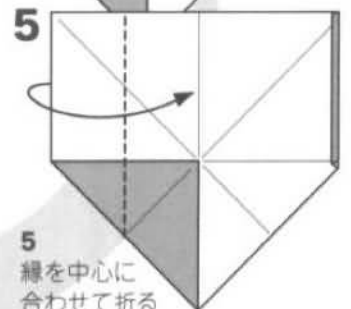
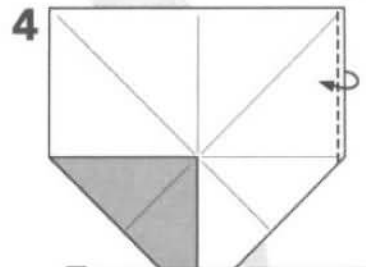

5 縁を中心に合わせて折る
Fold the left edge to the center.

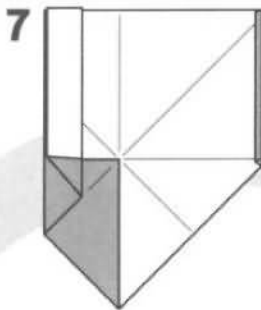

8 縁を中心に合わせて折る
Fold edge to edge.

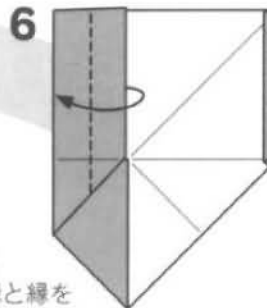

6 縁と縁を合わせて折る
Fold edge to edge.

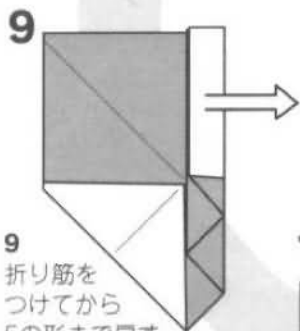
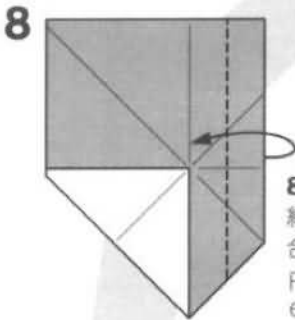

9 折り筋をつけてから5の形まで戻す
Unfold to 5.

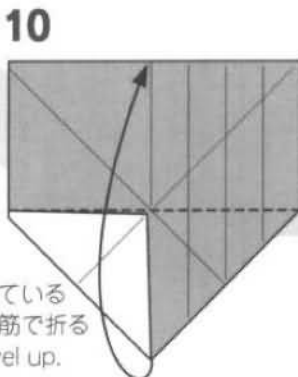

10 ついている折り筋で折る
Swivel up.

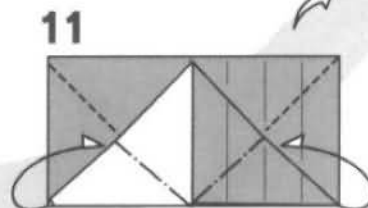

11 ついている折り筋でカドを内側に折る
Inside reverse fold along the precrease lines.

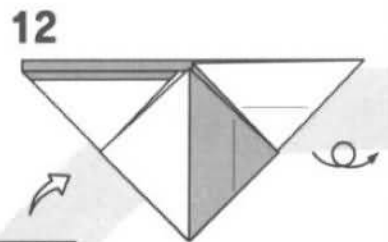

3 宇宙/天体望遠鏡

22
持ち上がった部分を
押し込むように折る
Flatten and assemble
while shifting the
starred corner
down.

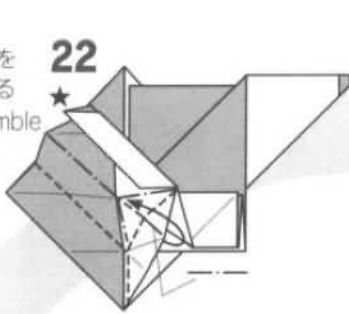

23
そのまま
折りまとめる
It should be assembled
this way.

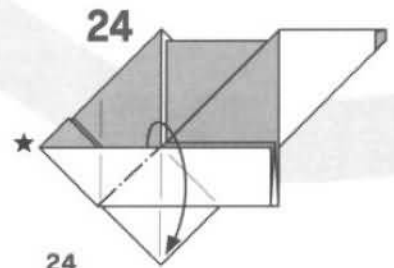
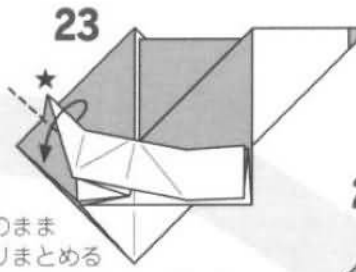

24
上の1枚を下に折る
Fold down the top layer.

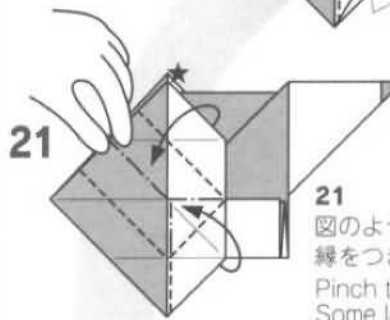

21
図のような折り筋で
縁をつまむように折る
Pinch the center line.
Some layers are
pulled up.

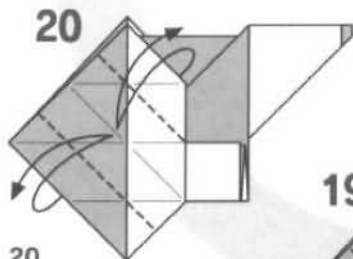

20
縁と折り筋を合わせて
折り筋をつける
Fold the edges to the
center.

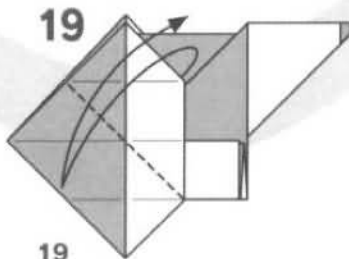

19
縁と縁を合わせて
折り筋をつける
Precrease edge to edge.

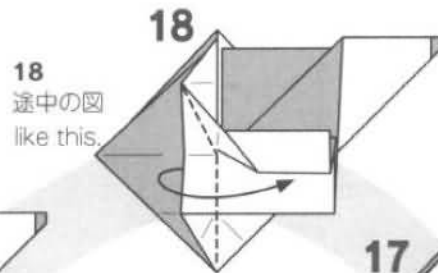

18
途中の図
like this.

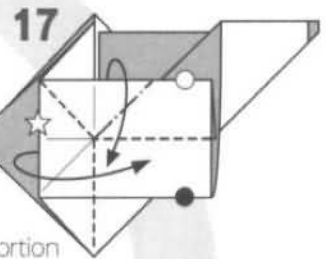

17
○と●の線を
合わせながら
☆の線を
反対側に折る
Swivel the left portion
to the right while folding
edge to edge on the right...

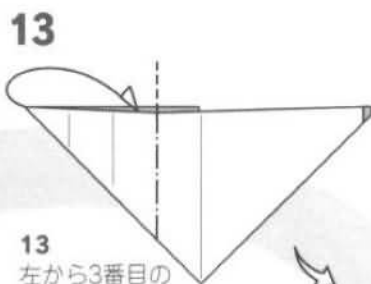

13
左から3番目の
折り筋でカドを
内側に折る
Inside reverse fold
along the third
crease line.

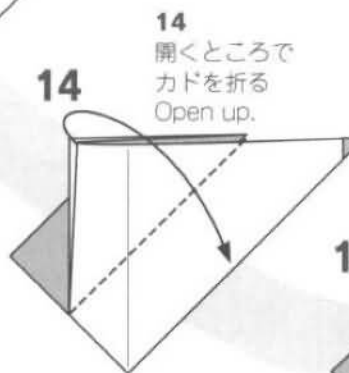

14
開くところで
カドを折る
Open up.



16
ついている折り筋で
縁を内側に折る
Mountain fold
along the
crease line.

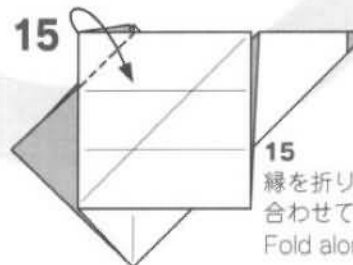

15
縁を折り筋に
合わせて折る
Fold along the edge.

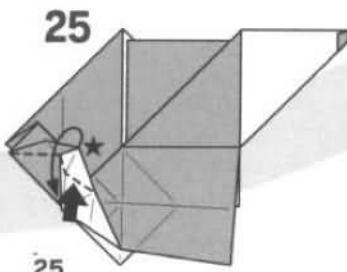

25
つられて持ち上がる
ところを押し込んで
つぶすように折る
Squash the pulled-up
layer.

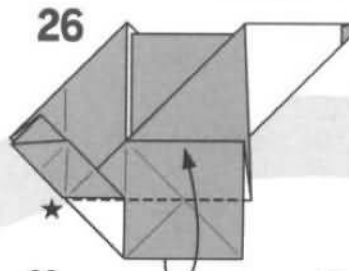

26
縁と縁を合わせて折る
Fold edge to edge.

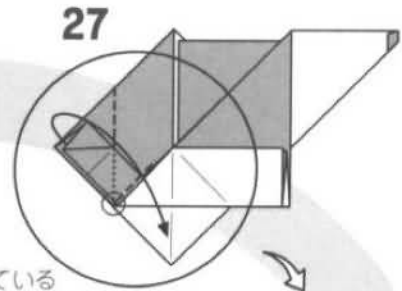

27
ついている
折り筋で内側を
ひろげるように折る
Swivel and open along
the precrease line.

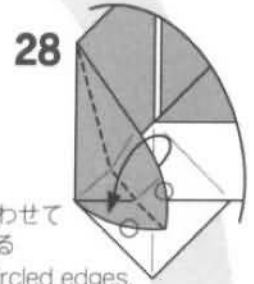

28
○と○を合わせて
折りまとめる
Align the circled edges.

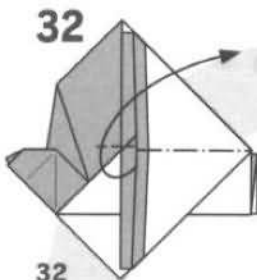

32
内側をひろげて
つぶすように折る
Open and squash.

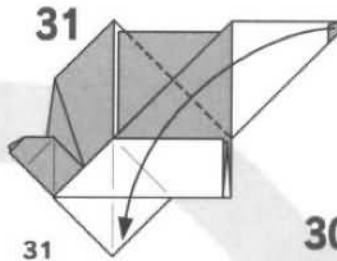

31
下の縁のところで
カドを斜めに折る
Fold along the
lower edge.

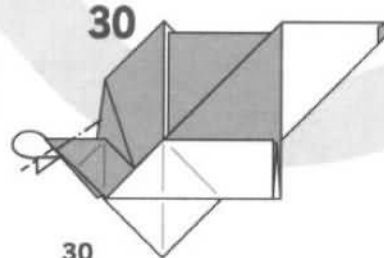

30
カドを内側に折る
Inside reverse fold.

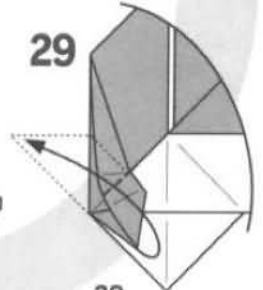

29
そのままカドを
反対側に折る
Swivel up.

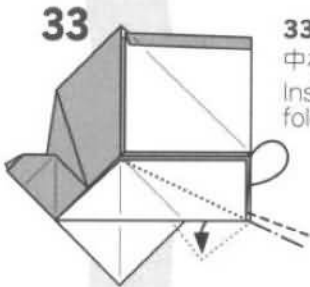

33
中わり折り
Inside reverse
fold.

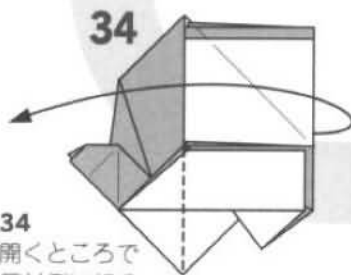

34
開くところで
反対側に折る
Swivel to the left
where it opens.

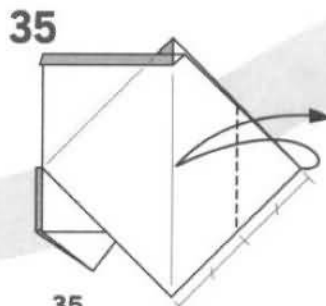

35
カドを折り筋に合わせ
て折り筋をつける
Fold the right corner
to the center line.

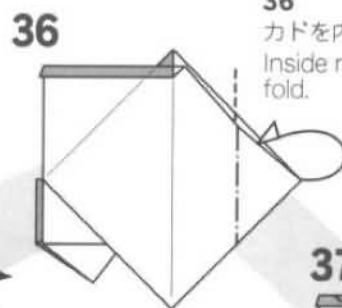

36
カドを内側に折る
Inside reverse
fold.

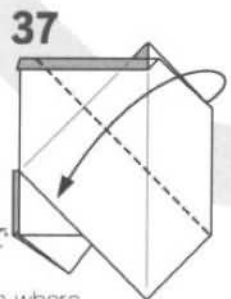

37
開くところで
斜めに折る
Swivel down where
it opens.

3

[本体]のすき間に
[三脚]を差し込む
Insert the top of the
tripod into the middle
pocket of the body.



4

[照準器]を[本体]の
すき間に差し込む
The sighting device
should be inserted
into the upper pocket
of the body.

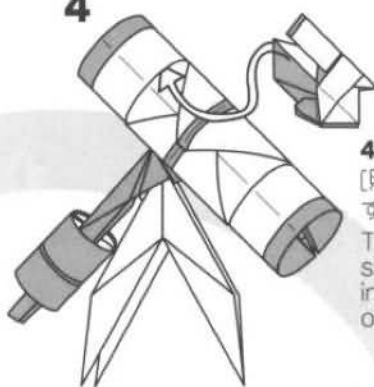

5



できあがり
Model Completed

2

おもりの内部のカドを
取っ手のかぶせ折りの部分に
引っかける感じにする
Hook the inner corner
of the weight to the outer
corner of the handle
made by the outside reverse
fold.

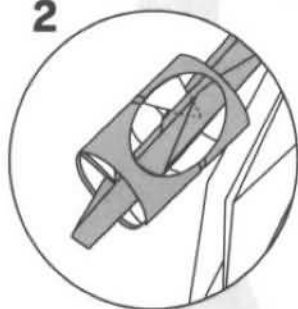

[組み立て方]
Assembly

1

[おもり]を
[三脚]の取っ手の
部分に差し込む
Insert the handle of the
tripod into the weight.

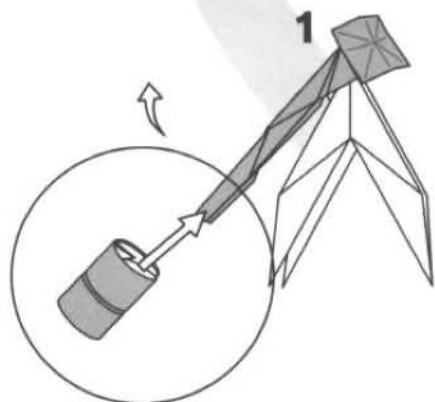

42

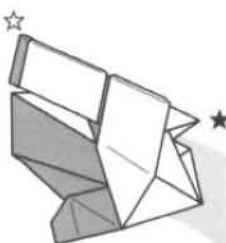

[照準器]の
できあがり
[Sighting Device]
Completed

41

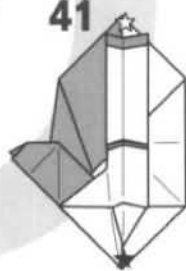

38

38
○と○を結ぶ線
を反対側に折る
Fold vertically along the
line starting from the
bottom corner.

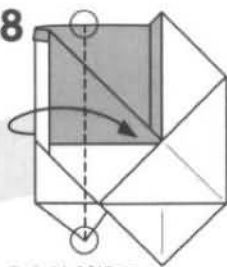

39

39
下の縁を38で折った線に
揃えて内側に折り込む
Tuck the lower edge
inside.

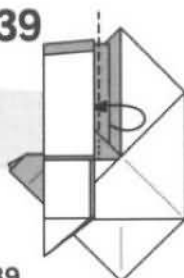

40

40
縁を起こして立体にする
Swivel up the edge and
make it three-dimensional.

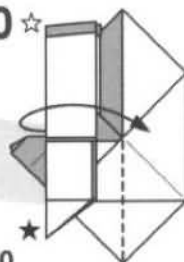

わし座・はくちょう座 こと座・さそり座

Aquila, Cygnus, Lyra, Scorpius

動物としての“それ”でなく、それぞれ星座の“それ”でなくては!との創作コンセプトから各星座の主星を表現しておくアイデアに至りました。このアイデアは他の星座へも応用できますが、夏の星座に絞ったこのあたりでとどめておきます。

As they all are constellations, not the creatures, the prominent stars are marked in the models. You go ahead and make other constellations.

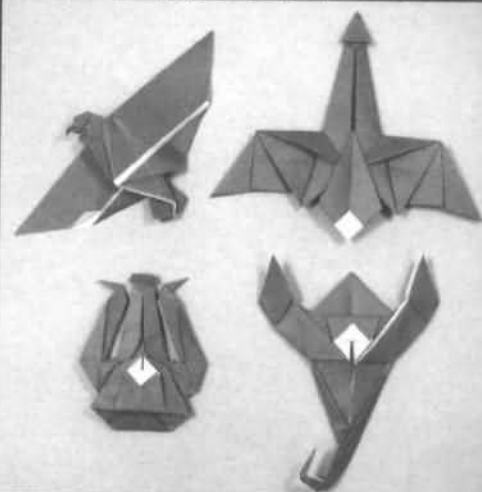

Created 1989 Paper 不切正方一枚折り: 1 piece

[わし座] Aquila

1

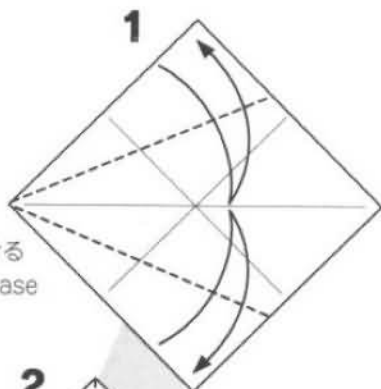

1 縁を中心に
合わせて
折り筋をつける
Fold a kite base
and unfold.

2

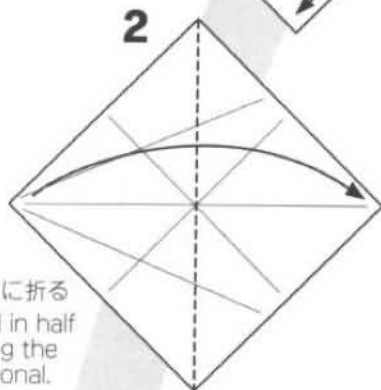

2 三角に折る
Fold in half
along the
diagonal.

3

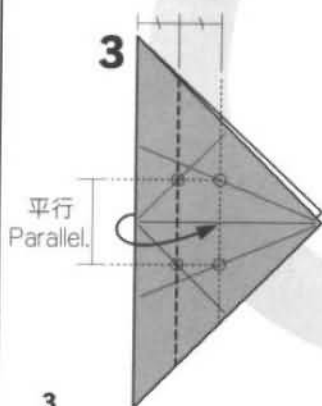

3 ○と○が平行になる位置で
縁を上折る
Fold where the intersections
can be aligned in parallel.

4

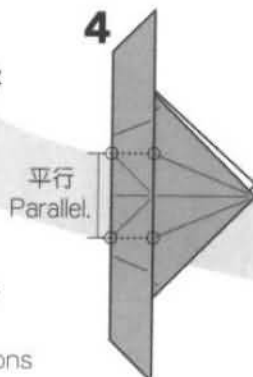

5

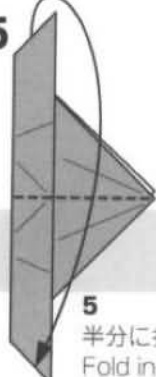

5 半分折る
Fold in half.

6

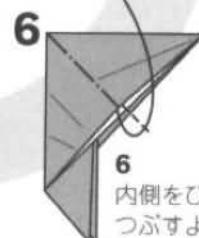

6 内側をひろげて
つぶすように折る
Open and squash.

8



8 反対側に折る
Swivel up.

9



9 内側をひろげて
つぶすように折る
Open and
squash.

10

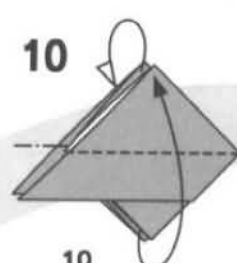

10 それぞれカドを
反対側に折る
Swivel up in front
and swivel down
on the back.

7

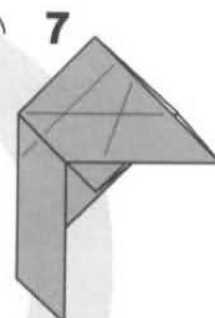

6

6 内側をひろげて
つぶすように折る
Open and squash.

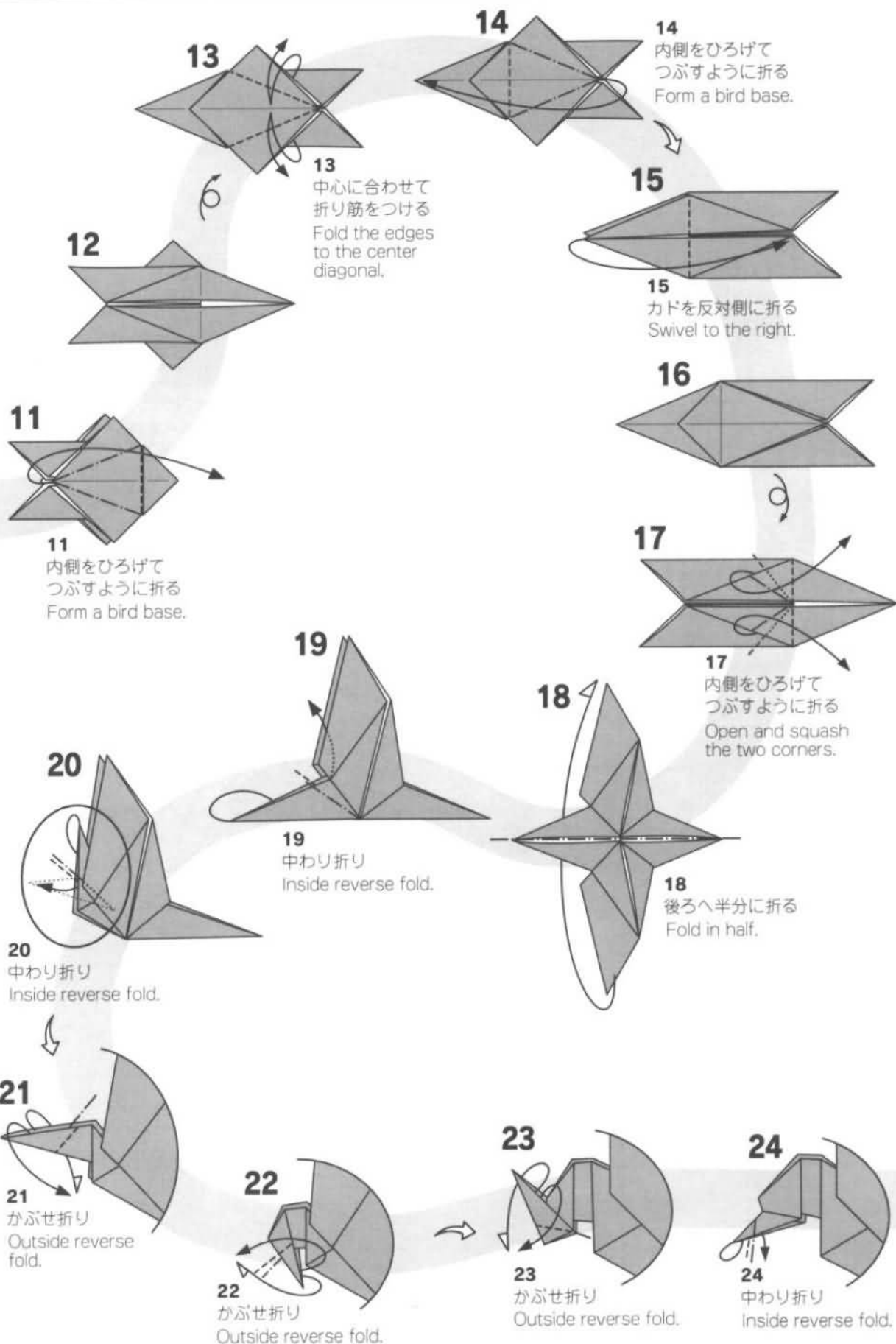

[はくちょう座]

Cygnus

1

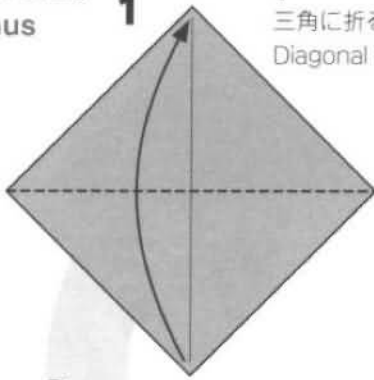

1
三角に折る
Diagonal fold.

2

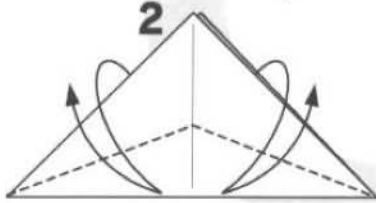

2
上の1枚だけ
縁と縁を合わせて
折り筋をつける
Fold edge to edge.

3

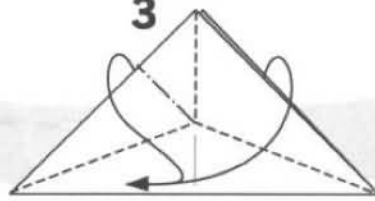

3
カドをつまむように折る
A rabbit-ear.

5

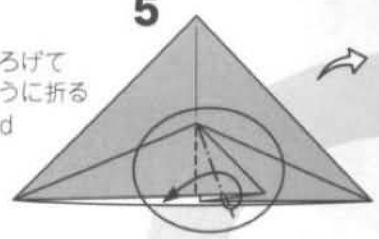

5
内側をひろげて
つぶすように折る
Open and
squash.

4

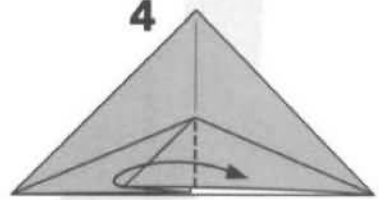

4
カドを反対側に折る
Swivel to the right.

32

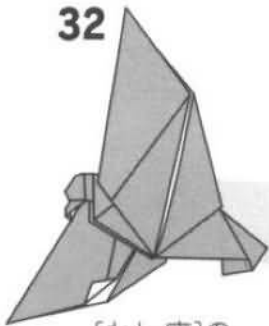

[わし座]の
できあがり
[Aquila] Completed

31

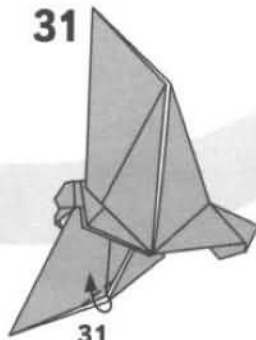

31
カドを少し折る
Fold the tip a little.

30

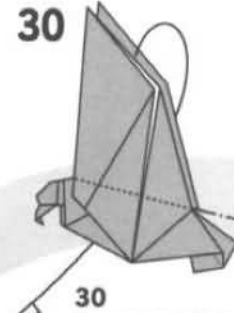

30
下のカドを後ろへ
斜めに折る
Fold the back
wing down.

29

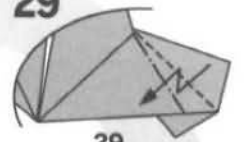

29
斜めに段折り
Form a pleat.

28

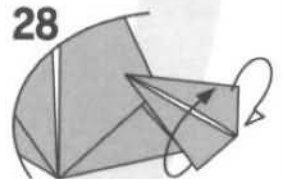

28
それぞれカドを
反対側に折る
Swivel up and
down.

25

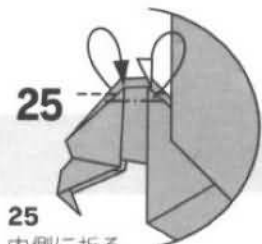

25
内側に折る
Tuck the corners inside.

26

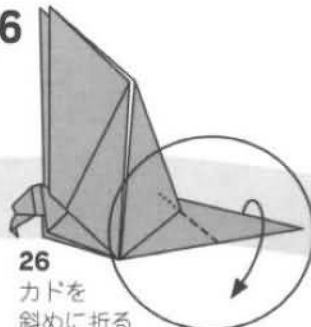

26
カドを
斜めに折る
Fold down.

27



27
内側をひろげて
つぶすように折る
Open and squash.

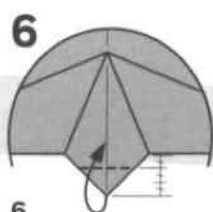

6
2/3のところで折る
Fold up at the two thirds of the triangle protruding at the bottom.

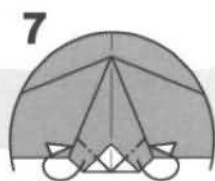

7
縁と縁を合わせて後ろへ折る
Mountain fold edge to edge.

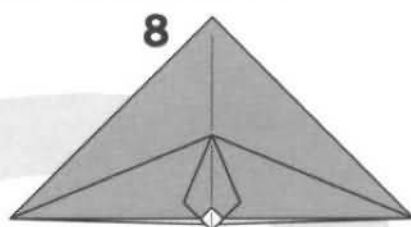

9
カドとカドを合わせて折る
Fold the side corners to the top.
Mountain fold edge to edge.

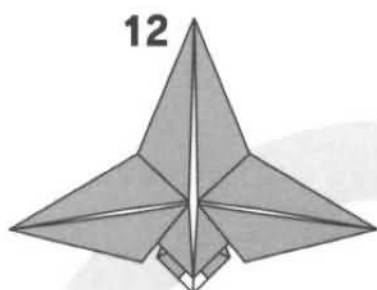
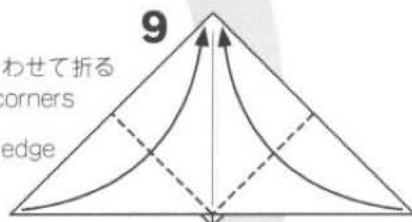

12

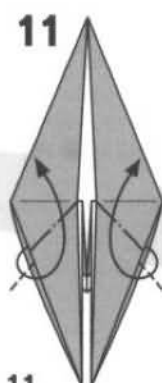

11

11
内側をひろげてつぶすように折る
Open and squash.

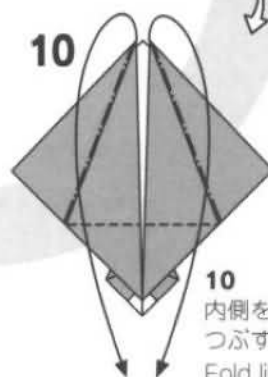

10

10
内側をひろげてつぶすように折る
Fold like a bird base.

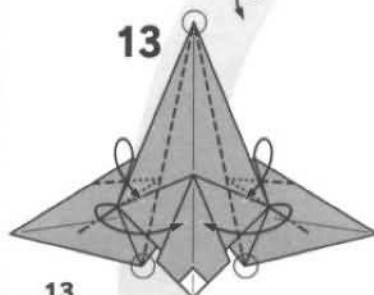

13

13
カドとカドを結ぶ線で折って内側をひろげてつぶすように折る
Narrow down along the line connecting the corners and squash.



14

14
カドを下のすき間に差し込む
Tuck the corners inside.

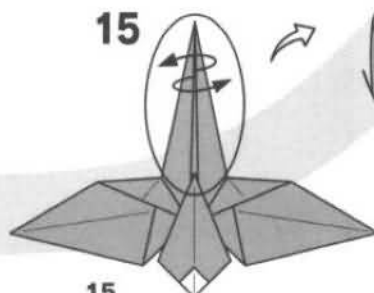

15

15
内側をひろげる
Open the top corner.

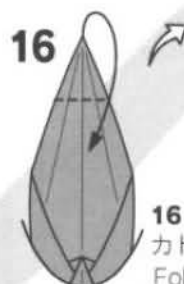

16

16
カドを下に折る
Fold down.

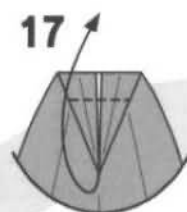

17

17
カドを上折る
Fold up.

[こと座] Lyra

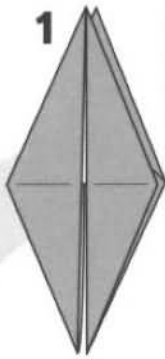

1 P. 8 [鶴の基本形] から始める
Start with [Bird Base] (P. 8)

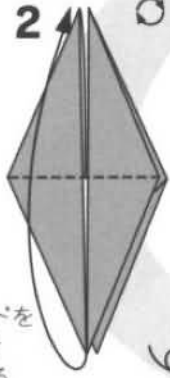

2 下のカドを1枚だけ上に折る
Swivel up.

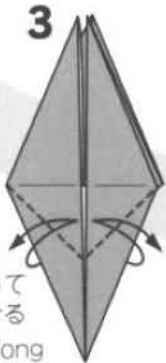

3 下の縁に沿って折り筋をつける
Precrease along the edges.

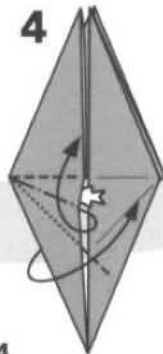

4 内側をひろげてつぶすように折る
Open and squash.



6 内側をひろげてつぶすように折る
Open and squash.

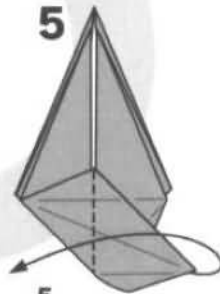

5 反対側へ折る
Swivel to the left.

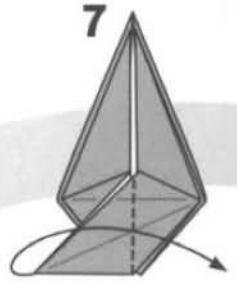

7 反対側へ折る
Swivel to the right.



18 縁と縁を合わせて内側をひろげてつぶすように折る
Open and squash.

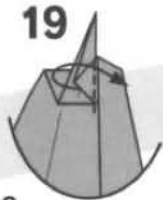

19 カドを反対側に折る
Swivel to the right.



20 反対側も18~19と同じ
Repeat 18~19 on the left.

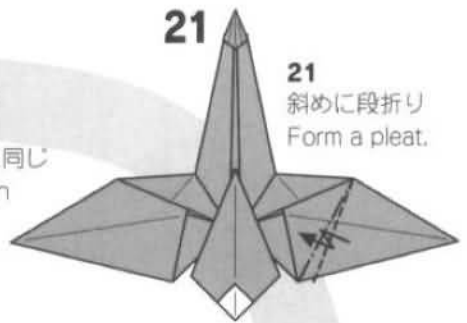

21 斜めに段折り
Form a pleat.

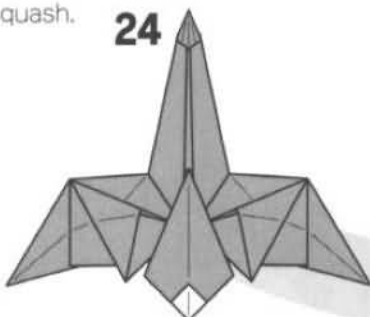

[はくちょう座]のできあがり
[Cygnus] Completed

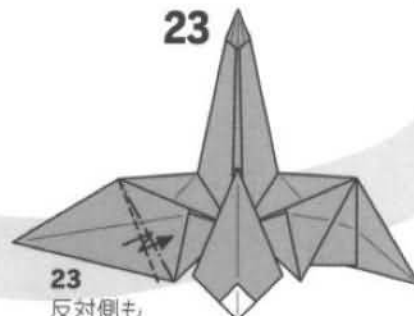

23 反対側も21~22と同じ
Repeat 21~22 on the left.

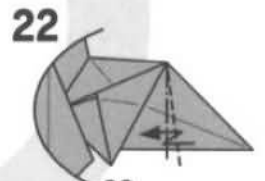

22 斜めに段折り
Form another pleat.

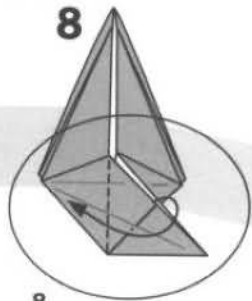

8
内側をひろげて
つぶすように折る
Open and squash.

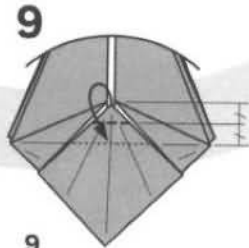

9
カドを少し折る
Fold down the tip.

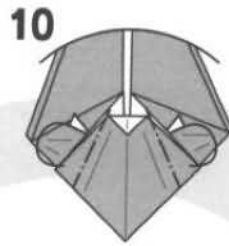

10
折り筋に平行に
カドを後ろへ折る
Mountain fold the corners
along the lines parallel with
the existing crease lines.

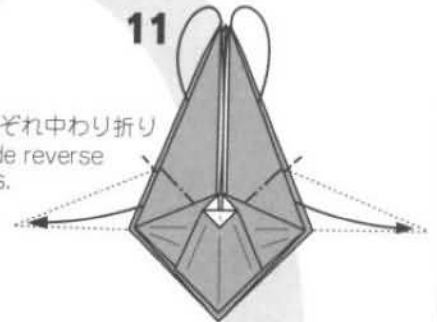

11
それぞれ中わり折り
Inside reverse
folds.

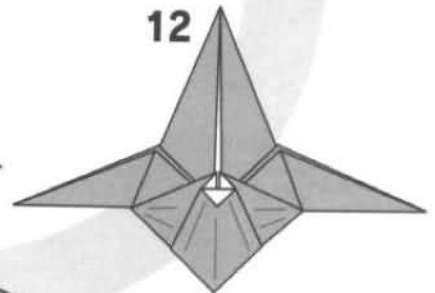

12

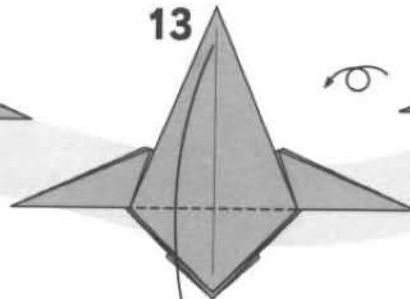

13

カドを下に折る
Fold down.

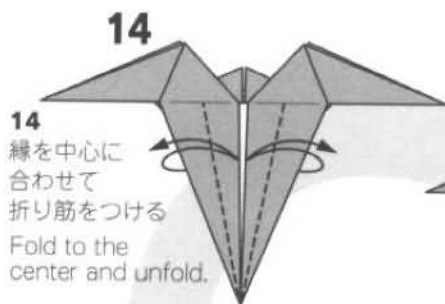

14
縁を中心に
合わせて
折り筋をつける
Fold to the
center and unfold.

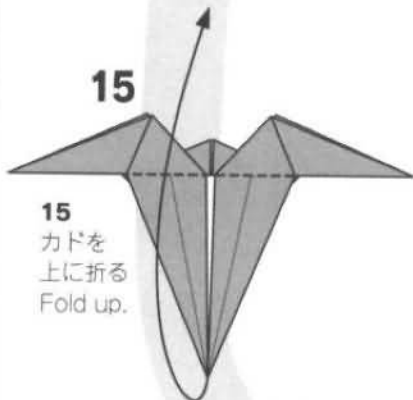

15
カドを
上に折る
Fold up.

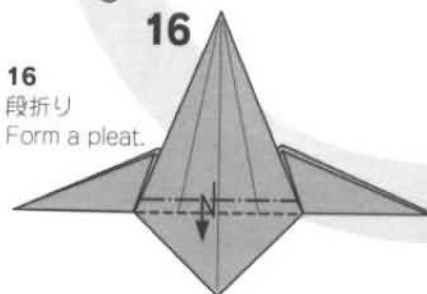

16
段折り
Form a pleat.

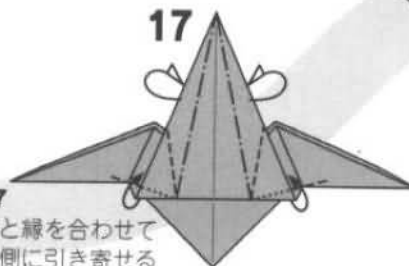

17
縁と縁を合わせて
内側に引き寄せる
ように折る
Mountain fold and slide the
layers on the sides.

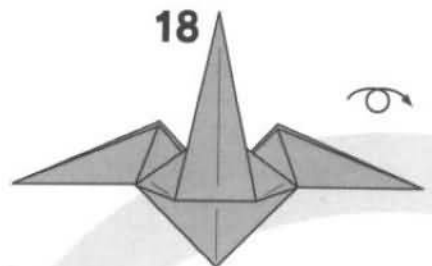

18

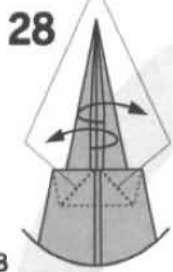

28
内側をひろげるように
紙を引き出す
Open and pull out
the layers.

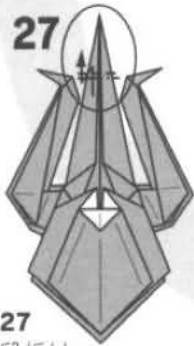

27
段折り
Form a pleat.

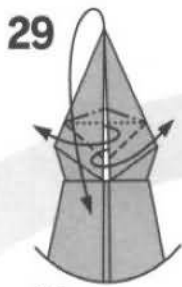

29
内側をひろげて
つぶすように折る
Open and squash.

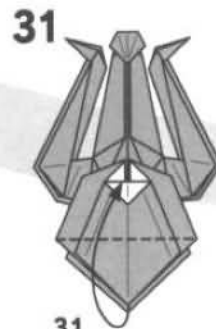
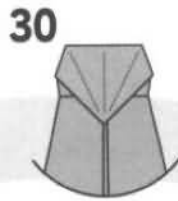

31
カドのところで
上に折る
Swivel up.

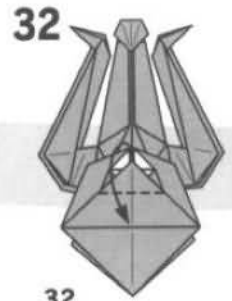

32
カドを下に折る
Fold down the
corner.

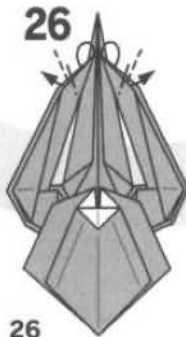

26
中わり折り
Inside reverse folds.

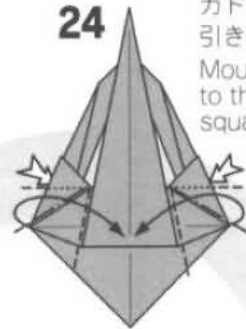
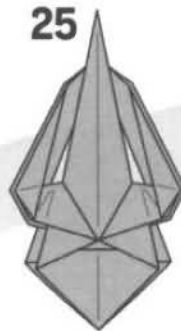

24
カドを中心に合わせて
引き寄せるように折る
Mountain fold the side
to the center and
squash.

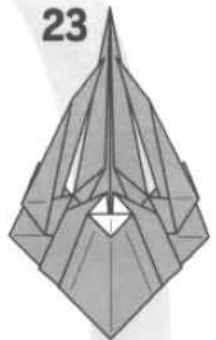

23

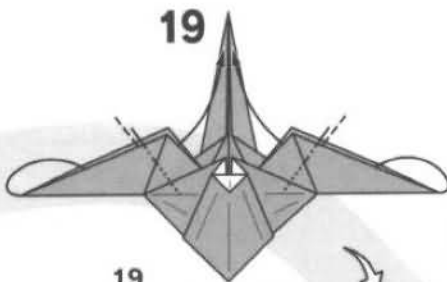

19
それぞれ中わり折り
Inside reverse folds.

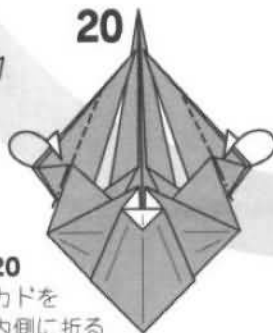

20
カドを
内側に折る
Inside reverse folds.

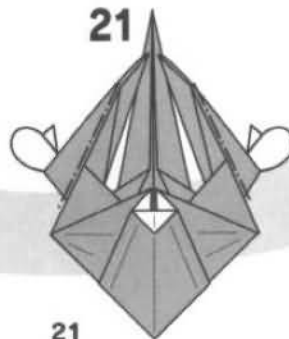

21
反対側も20と同じ
Inside reverse folds.

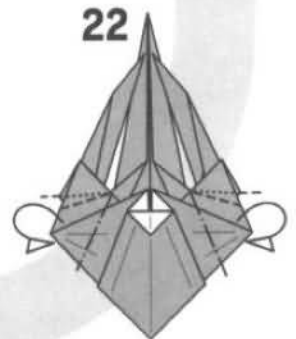

22
内側に引き寄せる
ように折る
Mountain fold the
sides and squash.

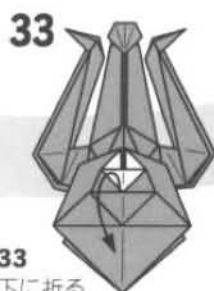

33
下に折る
Swivel down.

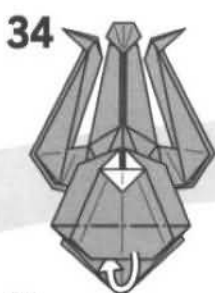

34
下のすき間に折り込む
Tuck inside the bottom
corner of the top layer.

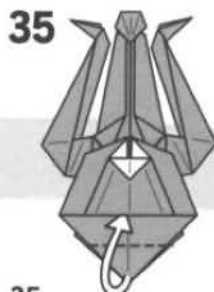

35
カドをすき間に差し込む
Tuck the bottom
corner inside.



36
[こと座]のできあがり
[Lyra] Completed

[さそり座] Scorpius

1
縁を中心に
合わせて折る
Fold the edges
to the center
line.

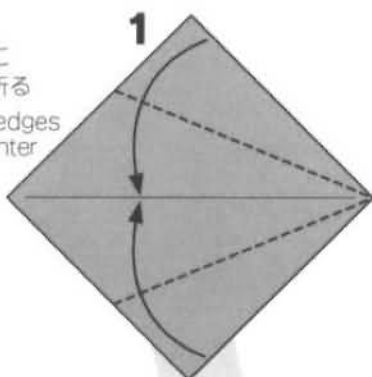

2
縁に沿って
カドを折る
Fold along
the edge.

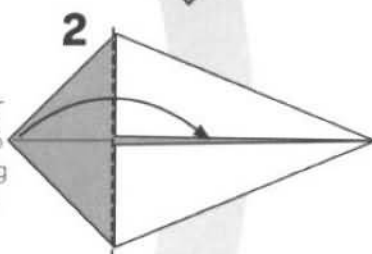

3
カドを折り筋に
合わせて
折り筋をつける
Fold the corners
to the center.

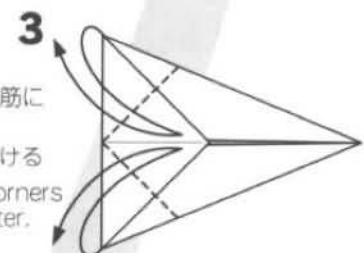

4
カドを内側に折る
Inside reverse folds.

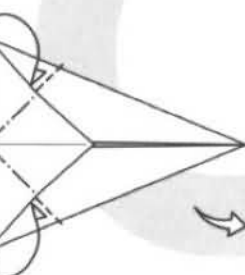

5
内側の部分を
引き出す
Pull out the
layers

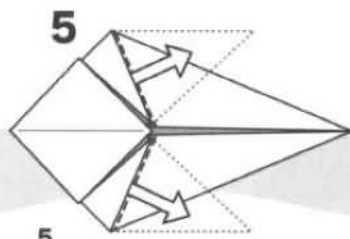

6
カドを少し折る
Valley fold the
tip of the
corner.

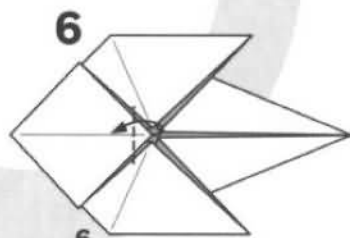

8
カドを
反対側に折る
Swivel to the
left.

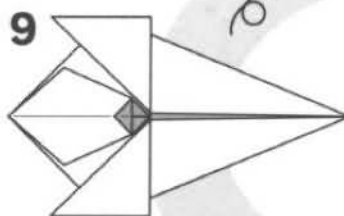
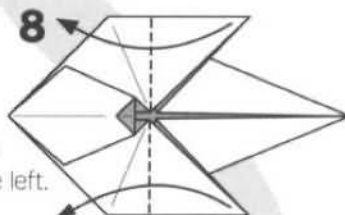

10
段折り
Form a pleat
outside.

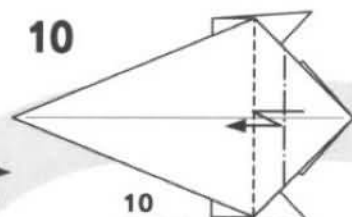

12

12
内側をひろげて
つぶすように折る
Slide the corner down.

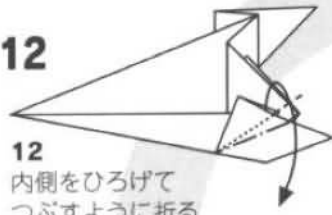

13

13
カドを後ろに折る
Mountain fold the corner.

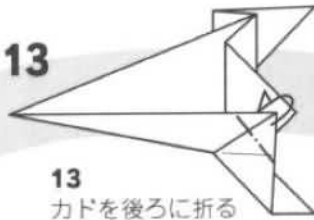

14

14
反対側も
11~13と同じ
Repeat 11~13
on the top.

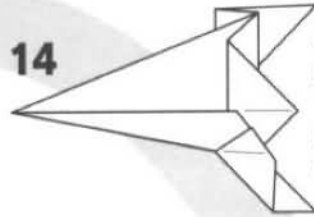

11

11
縁を折り筋に
合わせて折る
Fold the edge to
the center line.

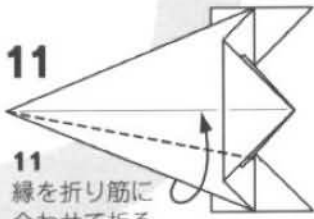

15

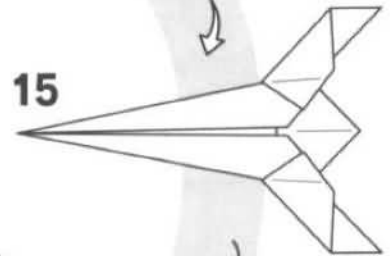

16

16
斜めに段折りしながら
内側をひろげて
つぶすように折る
Form pleats and
squash.

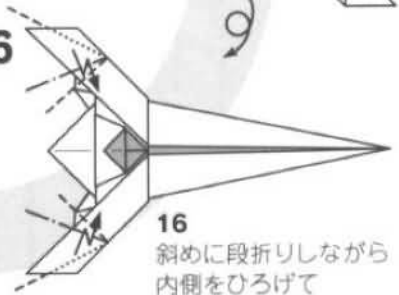

17

17
カドを斜めに折る
Fold the tail up.

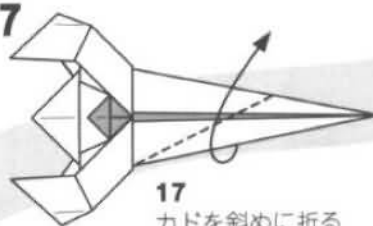

18

18
縁と縁を合わせて
折り筋をつける
Precrease edge
to edge.

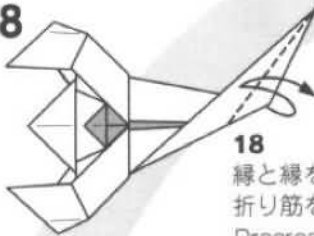

24

[さそり座]の
できあがり
[Scorpius]
Completed



19

19
カドをつまむように折る
Pinch the corner and
fold down.

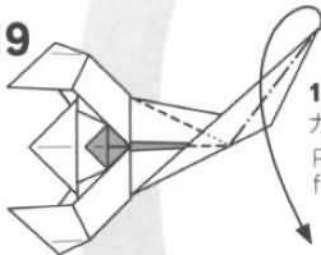

23

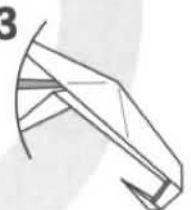

20

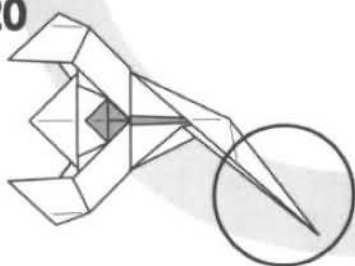

21

21
中わり折り
Inside reverse fold.

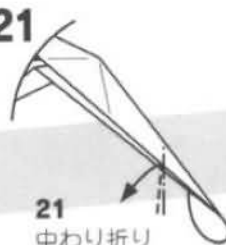

22

22
かぶせ折り
Outside reverse fold.



星の短冊

A Strip of Paper with a Star

前川淳さんの1:2の長方形で作るエレガントな“星”へのオマージュです。短冊にすることで実用性(?)を付加してみました。実際、家族にはすこぶる好評で毎年七夕近くになると何十個も折ることになります。

This is an homage to Maekawa's Star. It is very convenient as the decoration for the Star Festival (July 7th) season.

Created 1995 Paper 不切長方一枚折り: 1 piece

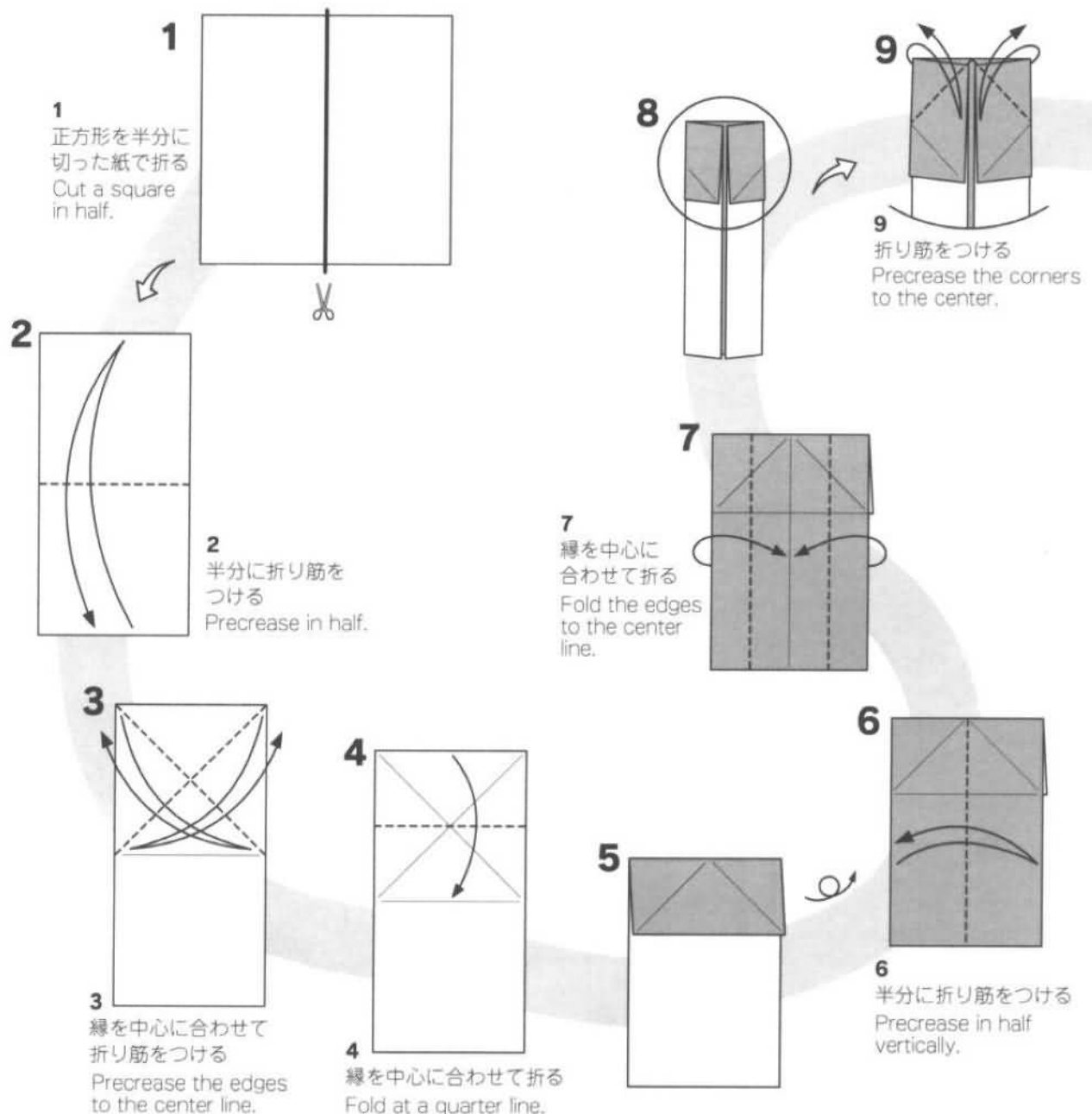
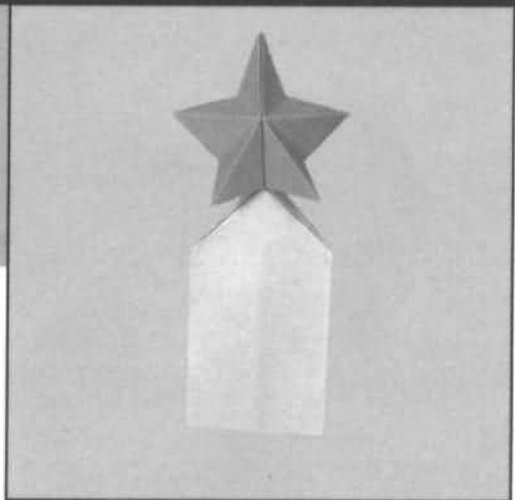

12
カドをつまむように
引き出す
反対側も同じ
Pull out the hidden
corner.
Repeat on the
right.

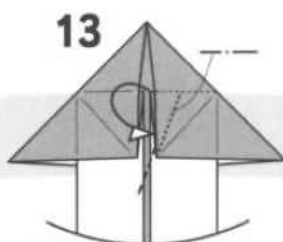
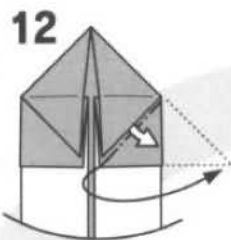

13
内側のカドを縁と縁を
合わせるように内側に折る
反対側も同じ
Fold the inner corner
to the edge.
Repeat on the right.

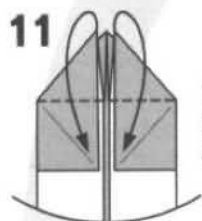
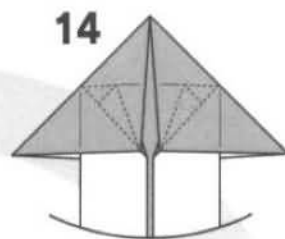

11
カドを下に折る
Swivel down.

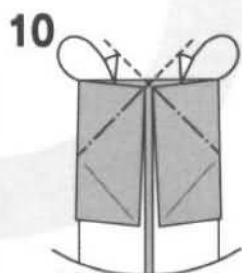

10
カドを内側に折る
Inside reverse folds.

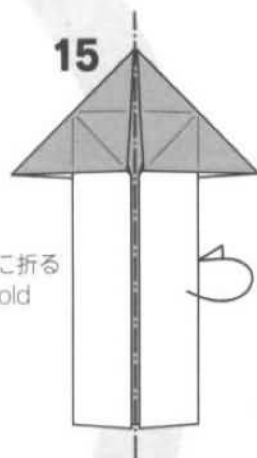

15
後ろへ半分に折る
Mountain fold
in half.



18
ついている折り筋で
中わり折り
Inside reverse
fold along the
crease line.

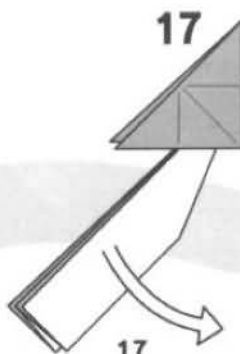

17
戻す
Unfold.

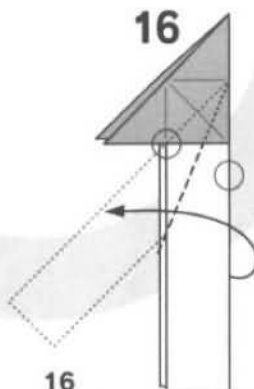

16
縁をカドに合わせて折る
Fold the right edge to the
intersection of the layers.

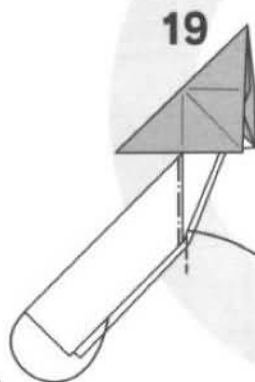

19
縁に沿って中わり折り
Inside reverse fold
along the edge.

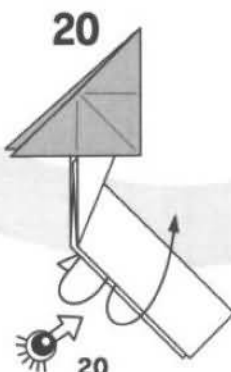

20
軽くひろげる
Open lightly.



21
星の部分をひろげて
形を整える
Open and shape
the star.

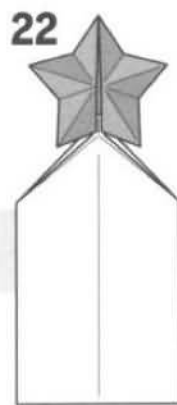

できあがり
Model Completed

ピエロ

(フリルバージョン/帽子バージョン)

Clown (A Frilled Version / A Hatted Version)

私の創作折り紙との最初の出会いは、河合豊彰先生の「おりがみ」(カラーブックスシリーズ 保育社)です。折り紙で面を作ることの大切さを河合先生の作品群から教わったのだと思います。いろいろな形から顔を“見立てる”姿勢がトラや本作を生む出発点になっています。

I first came across with the original origami models through Toyoaki Kawai's *Origami*. Kawai taught me the importance of origami masks and initial diagnosing of the target through his works.

Created 1984 Paper 複合作品・各2枚 : 2 pieces

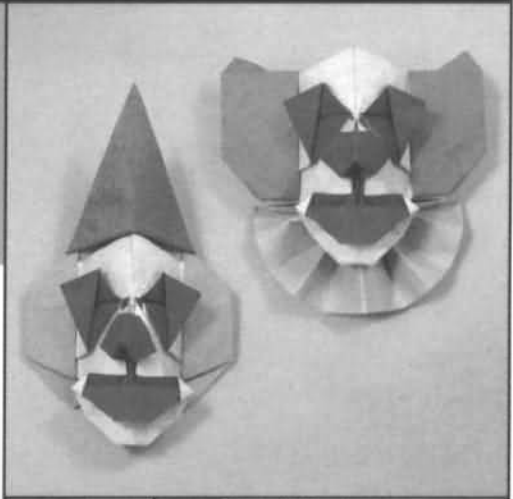

[顔] Face (Common Item)

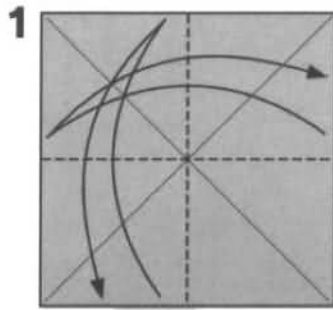

1 縦横半分に折り筋をつける
Fold in halves.

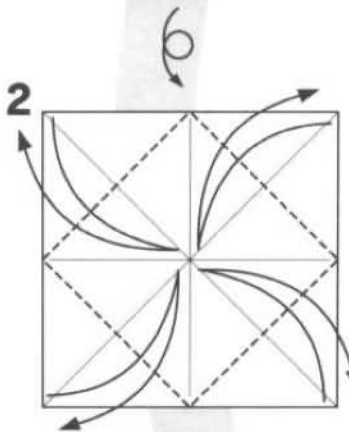

2 カドを中心に合わせて折り筋をつける
Precrease the corners to the center.

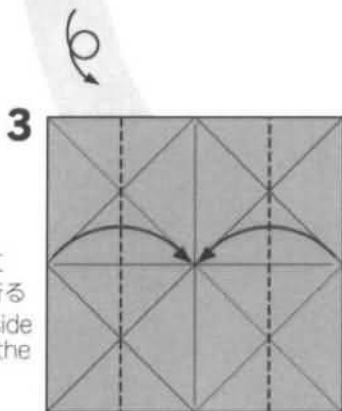

3 縁を中心に合わせて折る
Fold the side edges to the center.

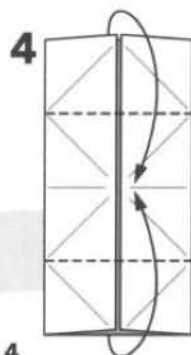

4 縁を中心に合わせて折る
Fold the horizontal edges to the center.

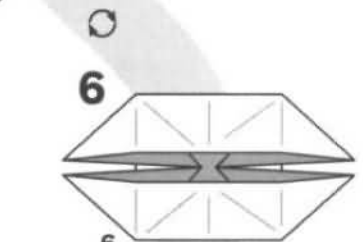
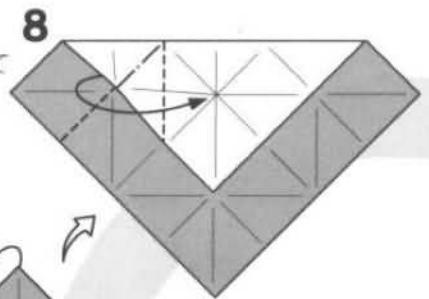

6 全部ひろげる
Unfold everything.

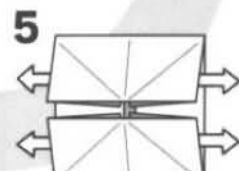

5 カドを引き出してつまむように折る
Pull out the corners.

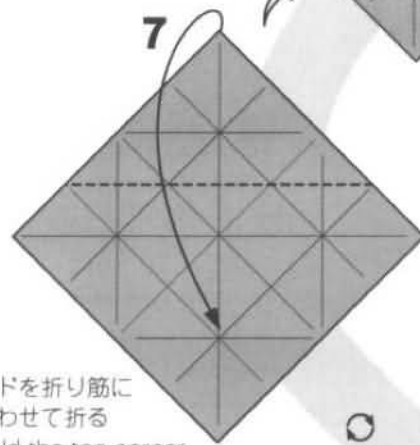

8 内側をひろげてつぶすように折る
Open and squash.

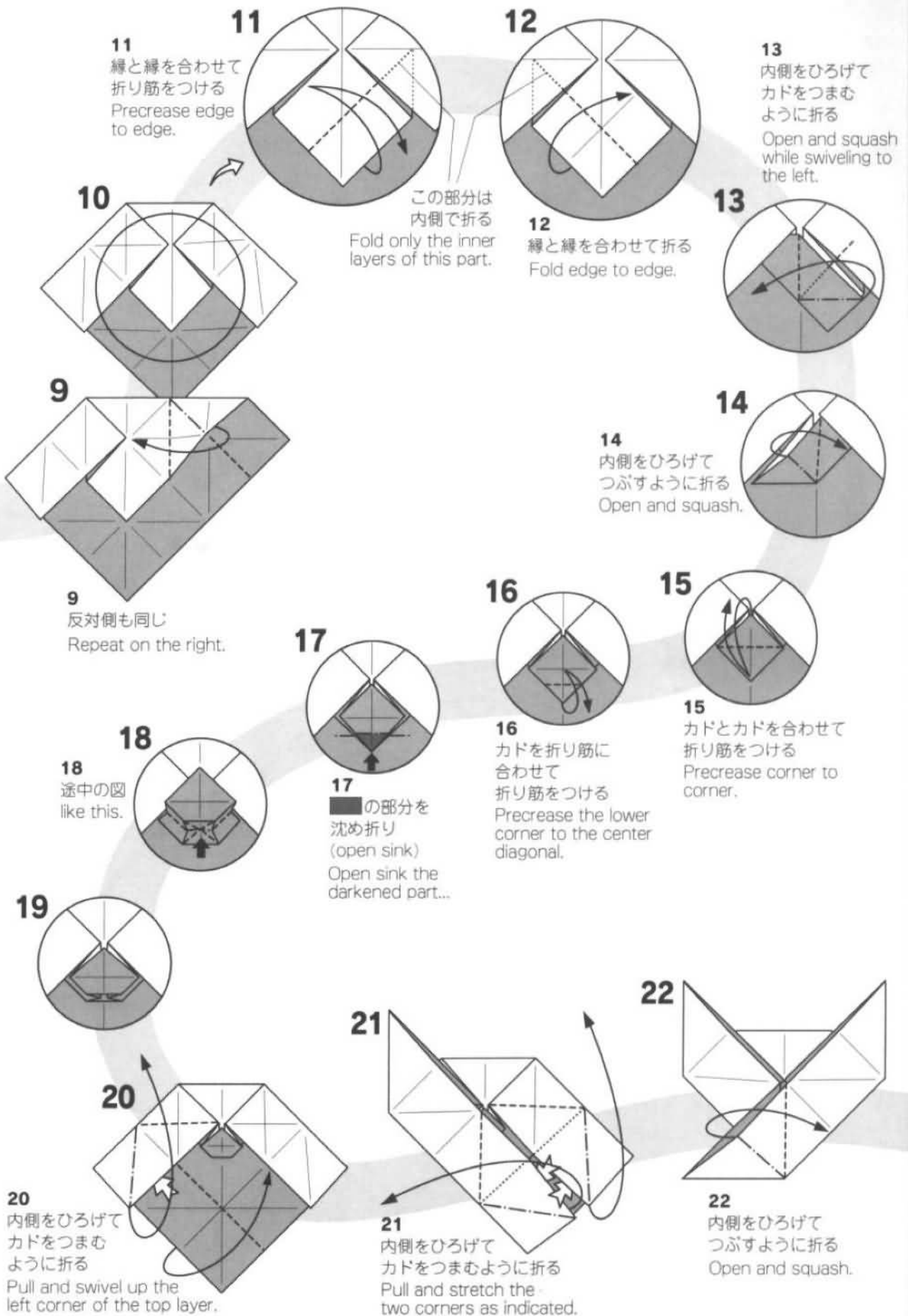

4 面/ピエロ (フリルバージョン・帽子バージョン)

33
内側をひろげて
つぶすように折る
Open and
squash.

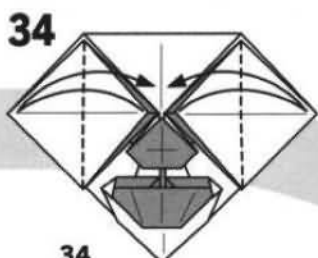
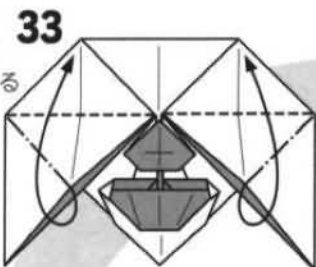

34
カドとカドを合わせて
折り筋をつける
Precrease corner
to corner.



35
カドを斜めに折る
Fold the corners
and show a small
amount of colored
layers.

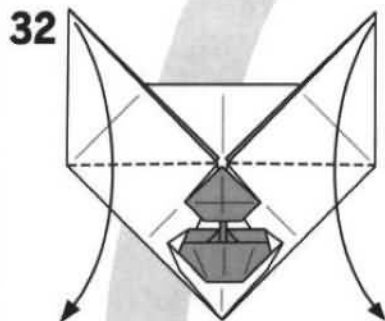

32
カドを下に折る
Swivel down.

27
内側をひろげて
つぶすように折る
Open the bird base
and squash.

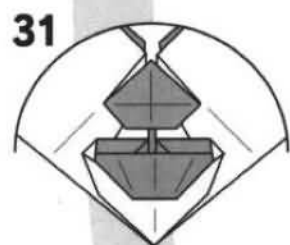
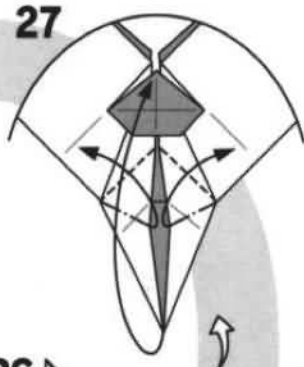

28
カドを折り筋に
合わせて折る
Fold down along
the hidden crease
line.

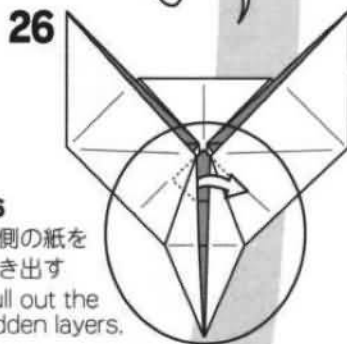
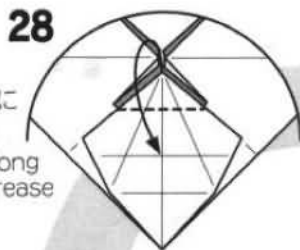

26
内側の紙を
引き出す
Pull out the
hidden layers.

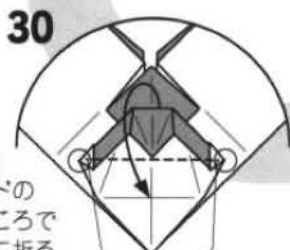

30
カドの
ところで
下に折る
Swivel down.

この部分は
内側で折る
Fold only the
inner layer here.

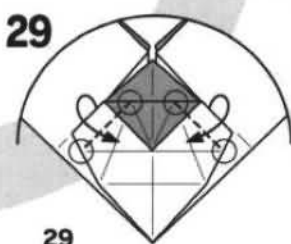

29
○と○を結ぶ線
で折る
Valley fold along the line
connecting the circled
intersections.

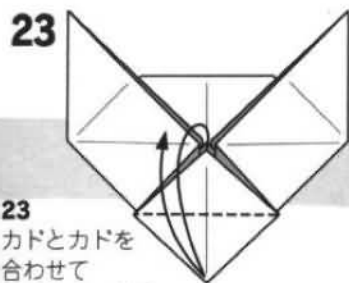

23
カドとカドを
合わせて
折り筋をつける
Precrease corner
to corner.



24
縁を折り筋に
合わせて
折り筋をつける
Precrease the edges
to the center diagonal.

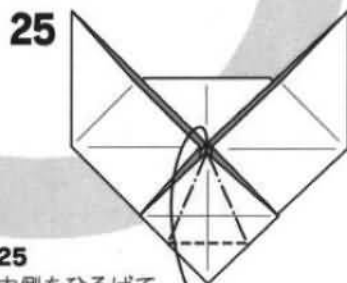

25
内側をひろげて
つぶすように折る
Form a bird base here.

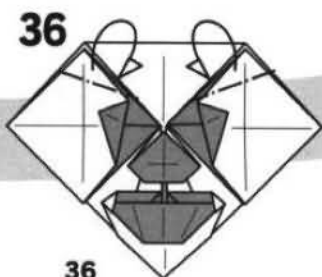

36
カドを後ろへ折る
Mountain fold the top corner.

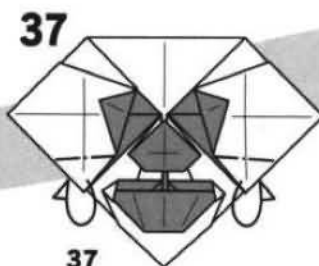

37
カドを後ろへ折る
Mountain fold the lower corner.

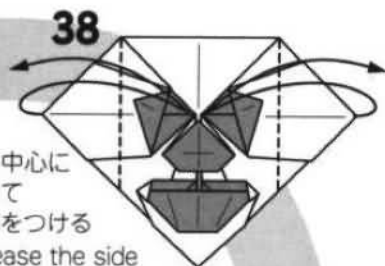

38
カドを中心に
合わせて
折り筋をつける
Precrease the side
corners to the center.

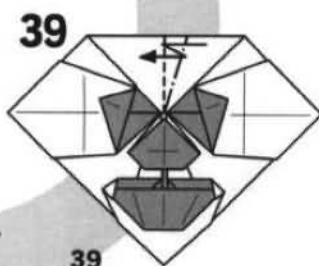

39
斜めに段折りして
顔の部分が立体に
なるようにする
Form a pleat and
make the face
three-dimensional.

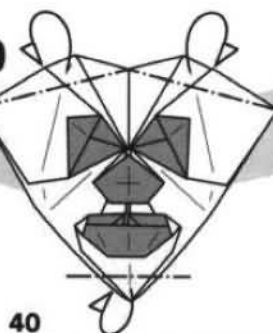
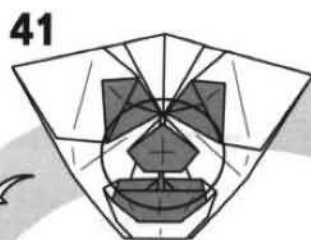

40
それぞれカドを後ろへ折る
Mountain fold the
three corners.



42
内側をひろげて
矢印の部分をかるく
押しつぶす
Insert a finger into the
opening on the top of
the nose and squash
the bottom of it.



43
鼻に丸みが出
るように
形を整える
Shape the nose.



44
カドを少し後ろへ折る
Mountain fold the top
corner of the nose.

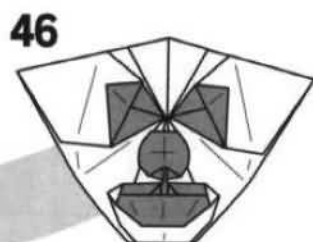
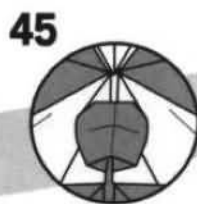

[顔]のできあがり
[Face] Completed

[フリルバージョン]
A Frilled Version

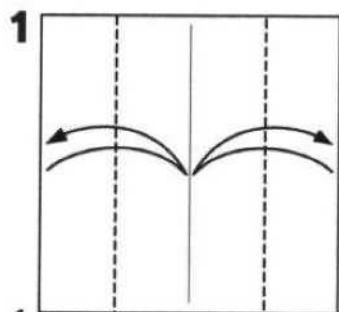

1
中心に合わせて折り筋をつける
Precrease the side edges to
the center.

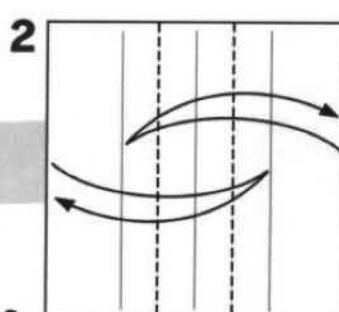

2
つけた折り筋に合わせて折り筋をつける
Precrease the side edges
to the crease lines in 1 on the far sides.

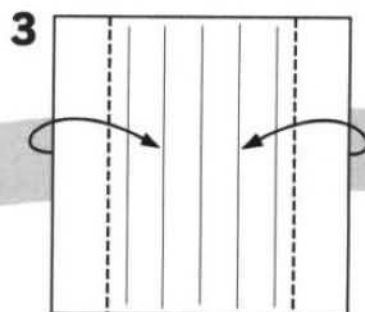

3
つけた折り筋に合わせて折る
Fold the side edges to the
crease lines in 2 on the near
sides.

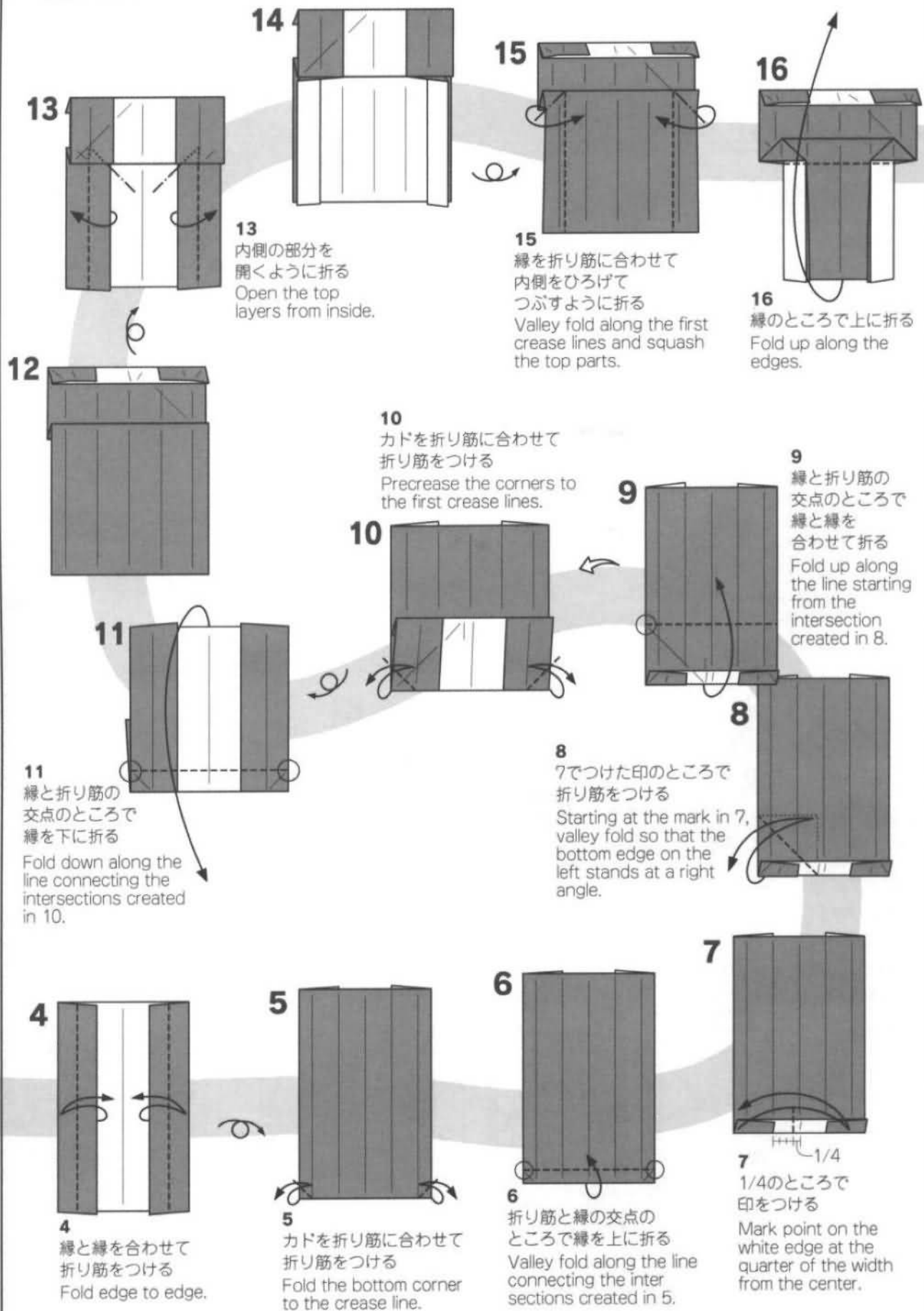

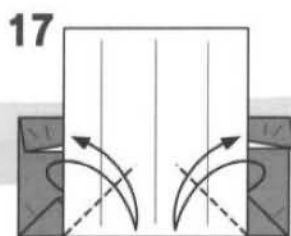

17
 線と線に合わせて
 折り筋をつける
 Precrease along
 the angle bisectors.

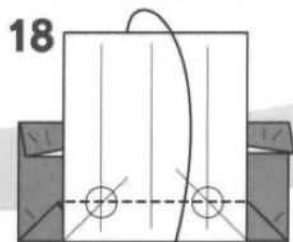

18
 折り筋の交点の
 ところで折る
 Fold down along the
 line connecting the
 intersections
 created in 17.

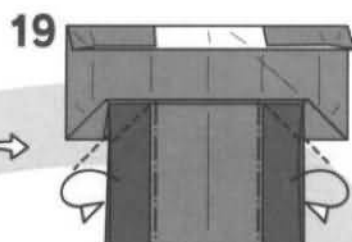

19
 ■の部分
 後ろへ折る
 Mountain fold the
 darkened parts.

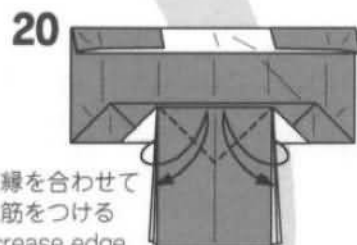

20
 線と線に合わせて
 折り筋をつける
 Precrease edge
 to edge.

23
 カドを結ぶ線で
 上に折る
 Fold up along the
 diagonals.

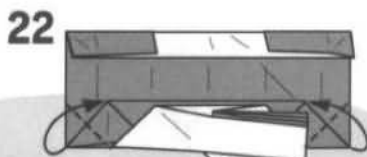
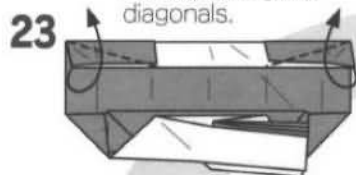

22
 カドとカドを合わせて折る
 Valley fold the corners
 to the first crease line.

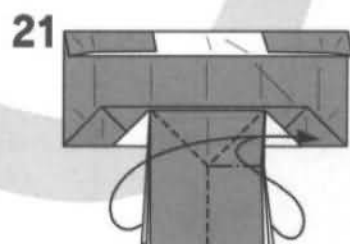

21
 つけた折り筋を
 使って折りたたむ
 Form a rabbit-ear.

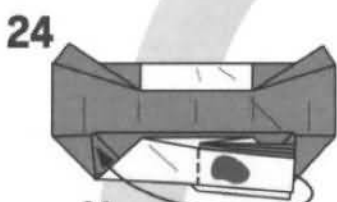

24
 ■の部分でのり付け
 Glue the darkened
 part to the left.

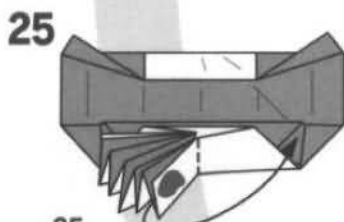

25
 反対側も同じようにのり付け
 Repeat on the right.

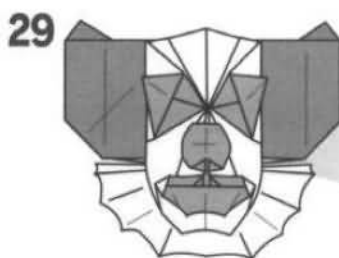

[フリルバージョン]
 のできあがり
 [A Frilled Version]
 Completed

顔を差し込むと
 顔に丸みが出て
 立体的になる
 The result naturally will
 be three-dimensional.

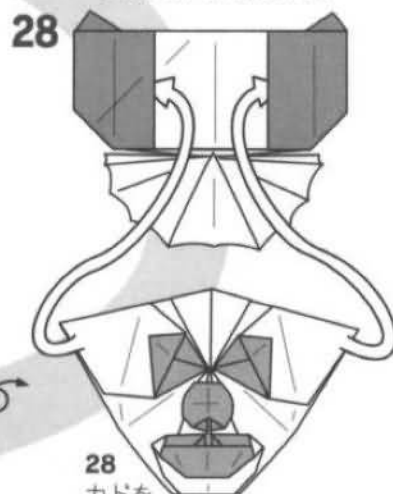

28
 カドを
 すき間に差し込む
 Insert the corners
 into the pockets.

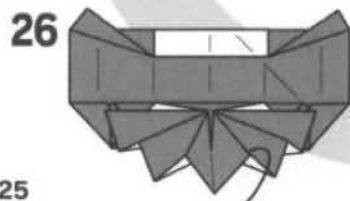

26
 襟の部分をひろげる
 Open and shape the frill.

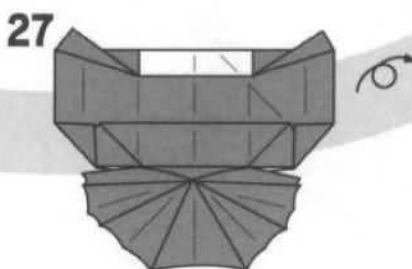

4 面/ピエロ (フリルバージョン・帽子バージョン)

[帽子バージョン]
A Hatted Version

※両面の折り紙用紙を使う
Use paper with
different-colored sides.

1
中心に合わせて折る
Fold the edges
to the diagonal.

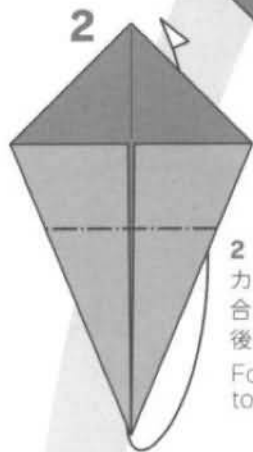
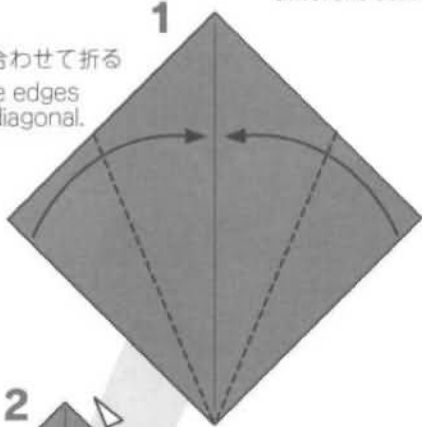

2
カドとカドを
合わせて
後ろへ折る
Fold up corner
to corner.

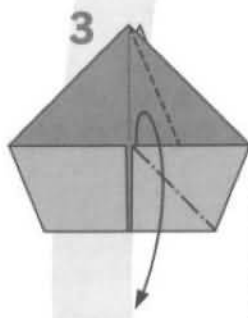

3
カドをつまむ
ように折る
Swivel down
and squash.

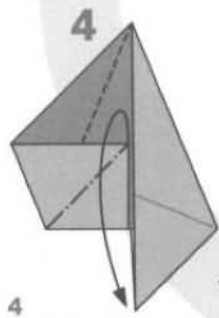

4
反対側も同じ
Repeat on the left.

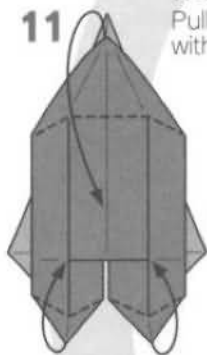
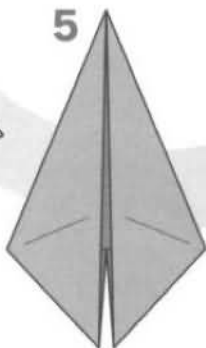

11
持ち上がった部分をつぶすように折る
Squash the pulled-up parts.

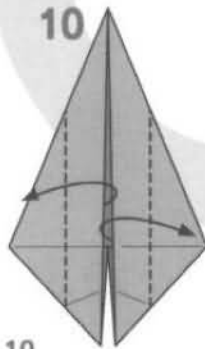

10
つけた折り筋を使って
内側をひろげる
Open from the inside
along the crease lines.



9
5の形に戻す
Unfold to 5.

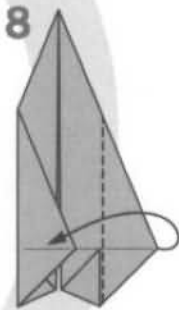

8
反対側も同じ
Repeat on
the right.

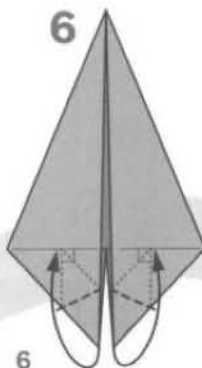

6
カドを折り筋に
合わせて上に折る
Fold up the corners
to the crease line.

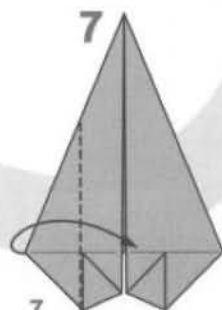

7
6で折ったカドの
縁のところを折る
Fold along the edge
created in 6.

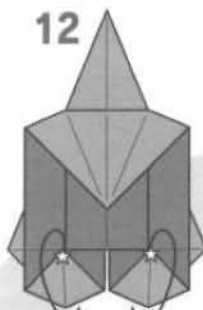

12
☆のカドを持ち上げる
Pull up the corners
with white stars.

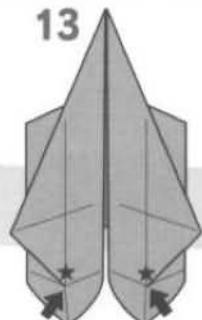

13
黒矢印の部分押し
込んで☆のカドを裏返す
Push in the corners
with dark stars and
form outside reverse
folds on the corners
with white stars.

14

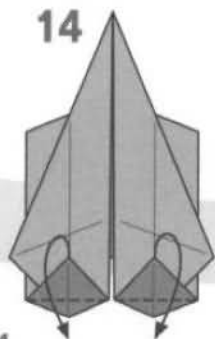

14
カドのところで下に折る
Swivel down the corners.

15

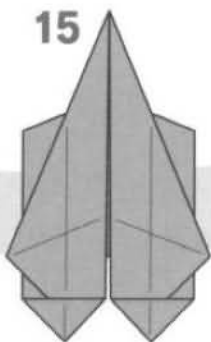

16

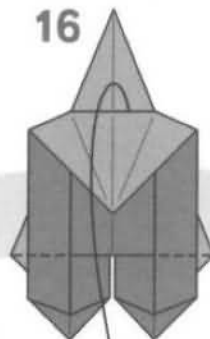

16
開くところで
縁を下に折る
Swivel down
where it opens.

17

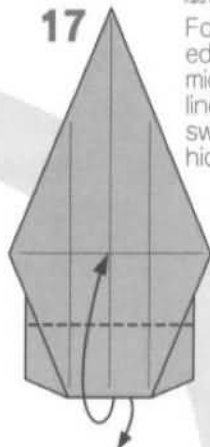

17
後ろのカドを出し
ながら縁を折り
筋に合わせて折る
Fold the bottom
edge to the
middle crease
line while
swiveling the
hidden corner.

21

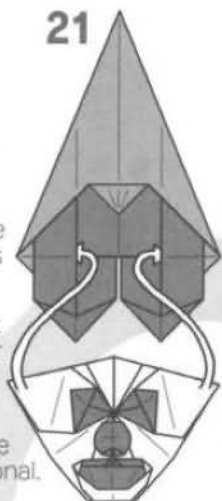

21
顔を差し込む
Insert the face
in the pockets
of the hat.
顔を差し込むと
顔に丸みが出て
立体的になる
The result
naturally will be
three-dimensional.

20

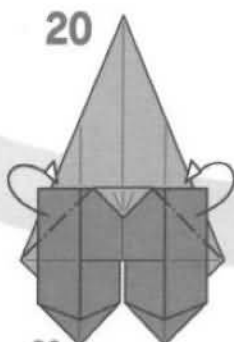

20
カドを後ろへ折る
Mountain fold
the corners.

19

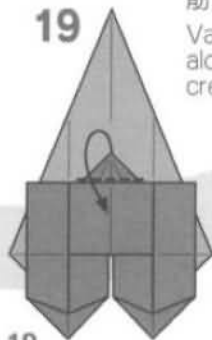

19
カドを縁のところで
下に折る
Fold down along
the edge.

18

18
ついている折り
筋で上に折る
Valley fold
along the
crease line.

18

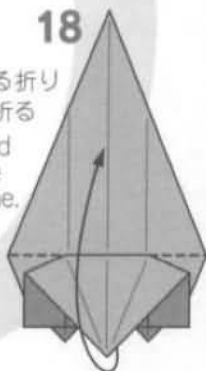

22

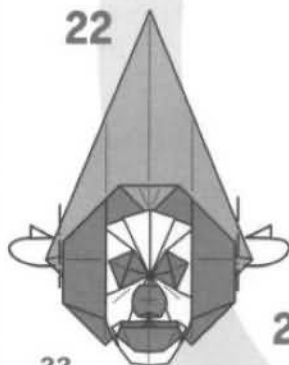

22
カドを後ろへ折る
Mountain fold
the corners.

23



23
段折り
Form a pleat.

24

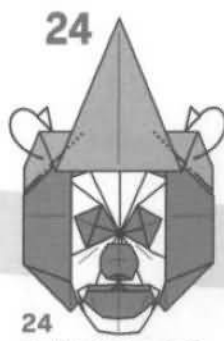

24
カドを後ろへ折る
Mountain fold the
corners.

25

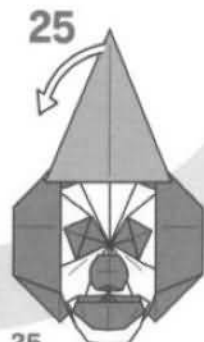

25
帽子を前に引き出す
Slide the hat to the
front.

26

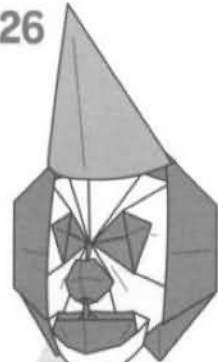

[帽子バージョン]
のできあがり
[A Hatted Version]
Completed

天狗

Tengu (A Japanese Legendary Mountain Goblin)

紙の中央から唇のパターンが自然に出来上がるのが本作のポイントです。次の仏面にも用いた鼻と口のテクニックの原点がこの天狗です。

Note the design of jaws and the nose, which are formed out of the central part of the sheet. I got inspired about the methods of folding the upper and lower jaws when I was making this model.



Created 1981 Paper 不切正方一枚折り: 1 piece

P. 8 [正方基本形]からはじめる

Start with
[Preliminary Base] (P. 8)

1

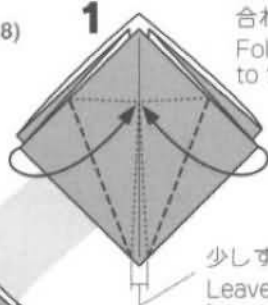

1
カドを中心に
合わせて折る
Fold the side corners
to the center diagonal.

少しすき間を開ける
Leave a small amount
intact at the bottom.

2

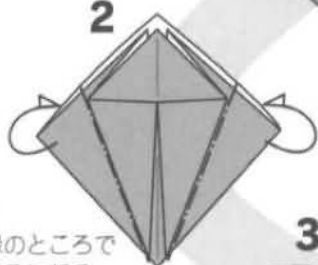

2
縁のところで
後ろに折る
Fold along
the edges.

3



3
内側の紙を引き出す
Pull out the hidden
corners...

4



4
途中の図
like this.

黒矢印の部分を押し込んで
つぶすように折る
Spread sink the arrowed area
around the bottom corner.

5

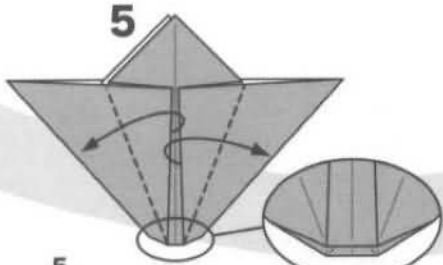

5
ついている折り筋で折る
Valley fold along the crease lines.

9

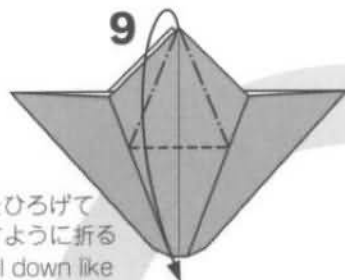

9
内側をひろげて
つぶすように折る
Swivel down like
a bird base.

8

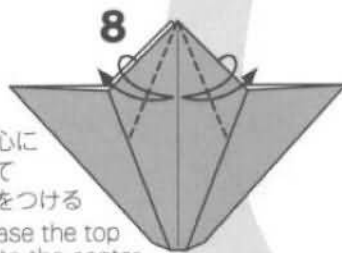

8
縁を中心に
合わせて
折り筋をつける
Precrease the top
edges to the center
line.

7

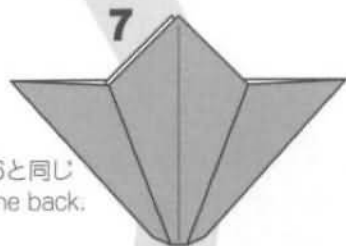

7
反対側も5~6と同じ
Repeat on the back.

6

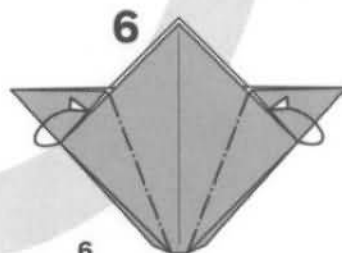

6
カドを内側に折る
Inside reverse folds.

12
 縁を中心に合わせて
 折り筋をつける
 Precrease the top
 edges to the
 center line.

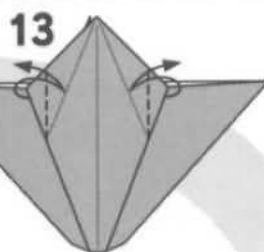
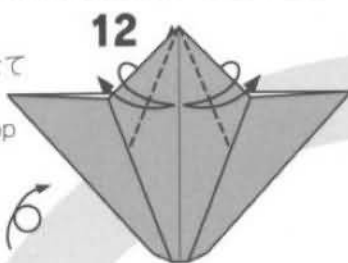

13
 縁を折り筋に合わせて
 折り筋をつける
 Precrease the edges
 to the crease lines in 12.

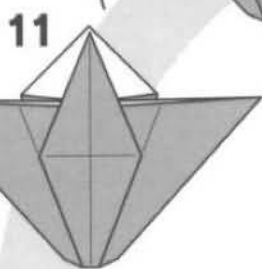

14
 つけた折り筋で
 カドを内側に
 引き寄せて折る
 Narrow the top
 corner using the
 existing crease lines.

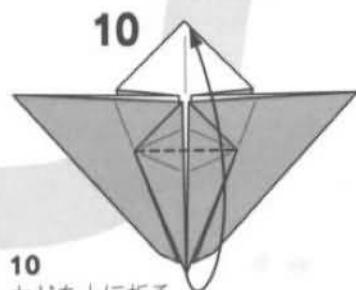
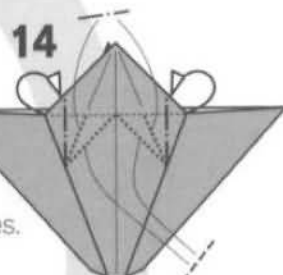

10
 カドを上へ折る
 Swivel up the corner.

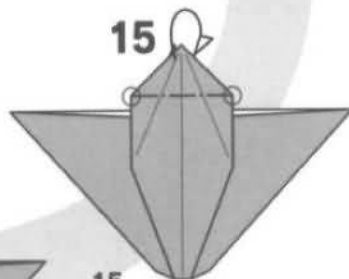

15
 カドを後ろに折る
 Mountain fold
 and
 hide the top corner.

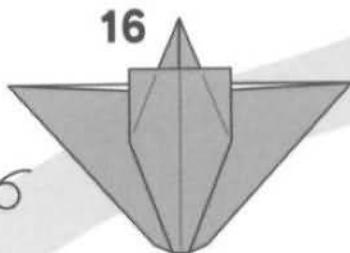

17
 1/3のところで折る
 Fold up at the third
 of the length to the
 first crease line from
 the bottom.

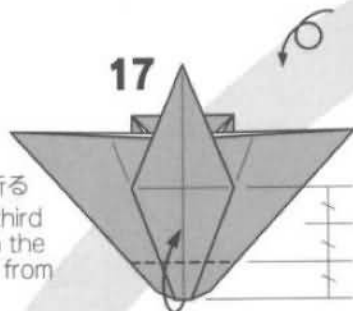

23
 ○のところから折って☆の
 縁を★のカドに合わせて折る
 Fold down and let the edges
 with white stars be on top of
 the corners with dark stars.
 The crease line should start at
 the circled intersections.

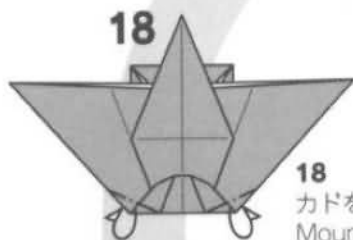
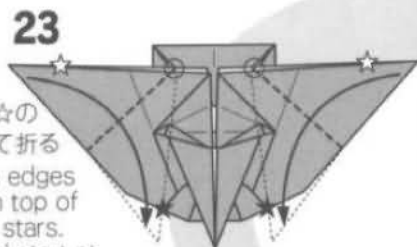

18
 カドを後ろへ折る
 Mountain fold
 the corners.

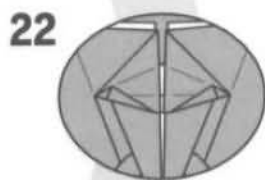

19
 少し残して
 カドを下に折る
 Valley fold.
 Note that the crease
 line here is above the
 existing one.

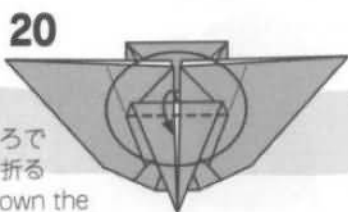

20
 開くところで
 縁を下に折る
 Swivel down the
 overlapping layers.

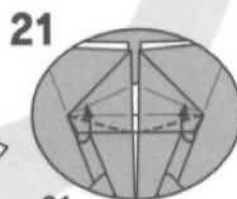

21
 カドを斜めに折る
 Fold up along the diagonals.

27
カドを後ろへ折る
Mountain fold
the side corners.

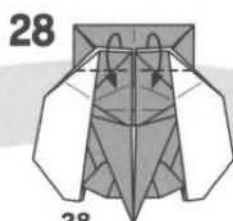
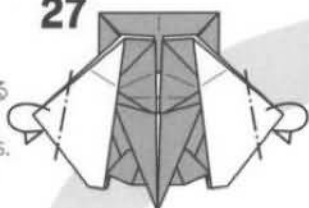

28
縁を下へ折る
Swivel down
the layers.

29
折り筋をつけてから
上の1枚だけ戻す
Unfold only the top layer.

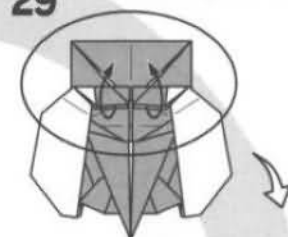

26
カドを内側に
折る
Inside reverse
folds.

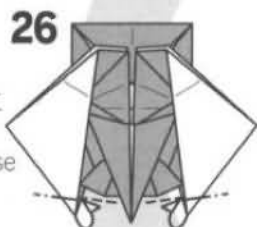

30
すき間に差し込む
Tuck the top
layer inside.

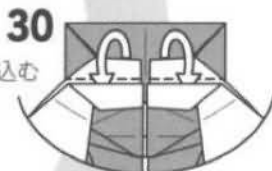

25
つけた折り筋で
かぶせ折り
Outside reverse
fold using the
crease lines in 23.

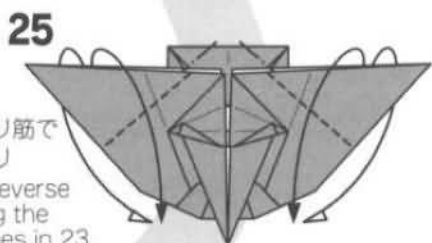

31
カドを後ろへ折る
Mountain fold
the corners.

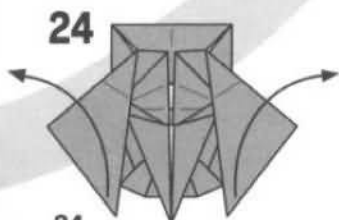
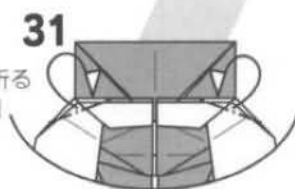

24
折り筋をつけてから戻す
Unfold.

32
下の縁にかぶせる
ように段折り
Pleat outside.

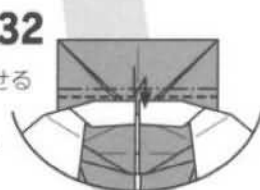

38
鼻を起こす
The nose
should stand
up.

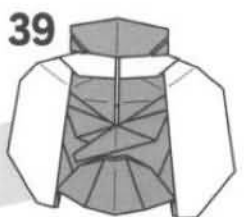
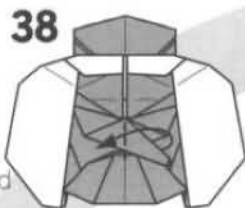

できあがり
Model Completed

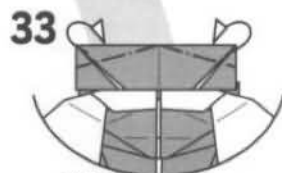

33
カドを後ろへ折る
Mountain fold
the corners.

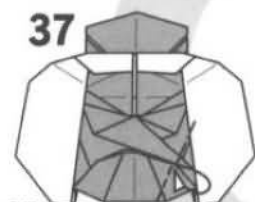

37
カドを内側に折る
Inside reverse fold.

36
カドをつまむ
ように折る
Form a rabbit ear.

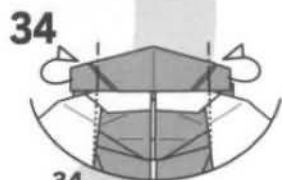
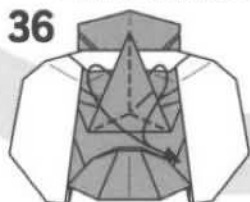

34
後ろへ折って留める
Mountain fold and
lock the cap.

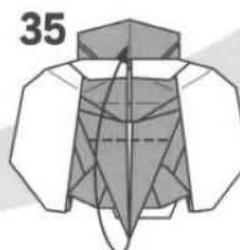

35
カドを上へ折る
Swivel up.

仏面

Buddha

広隆寺の弥勒菩薩像をモチーフにしています。仏面は、ちょっとした折りの違いで印象の異なる表情に仕上がります。図で工程を理解したら、気に入った表情を得るように鼻や顎の分量を工夫してみてください。

This model is based on the Mytraya statue in Koryu-Ji. You can shape the expressions of the mask by changing the size of the nose and the lower jaw.



Created 1983 Paper 不切正方一枚折り: 1 piece

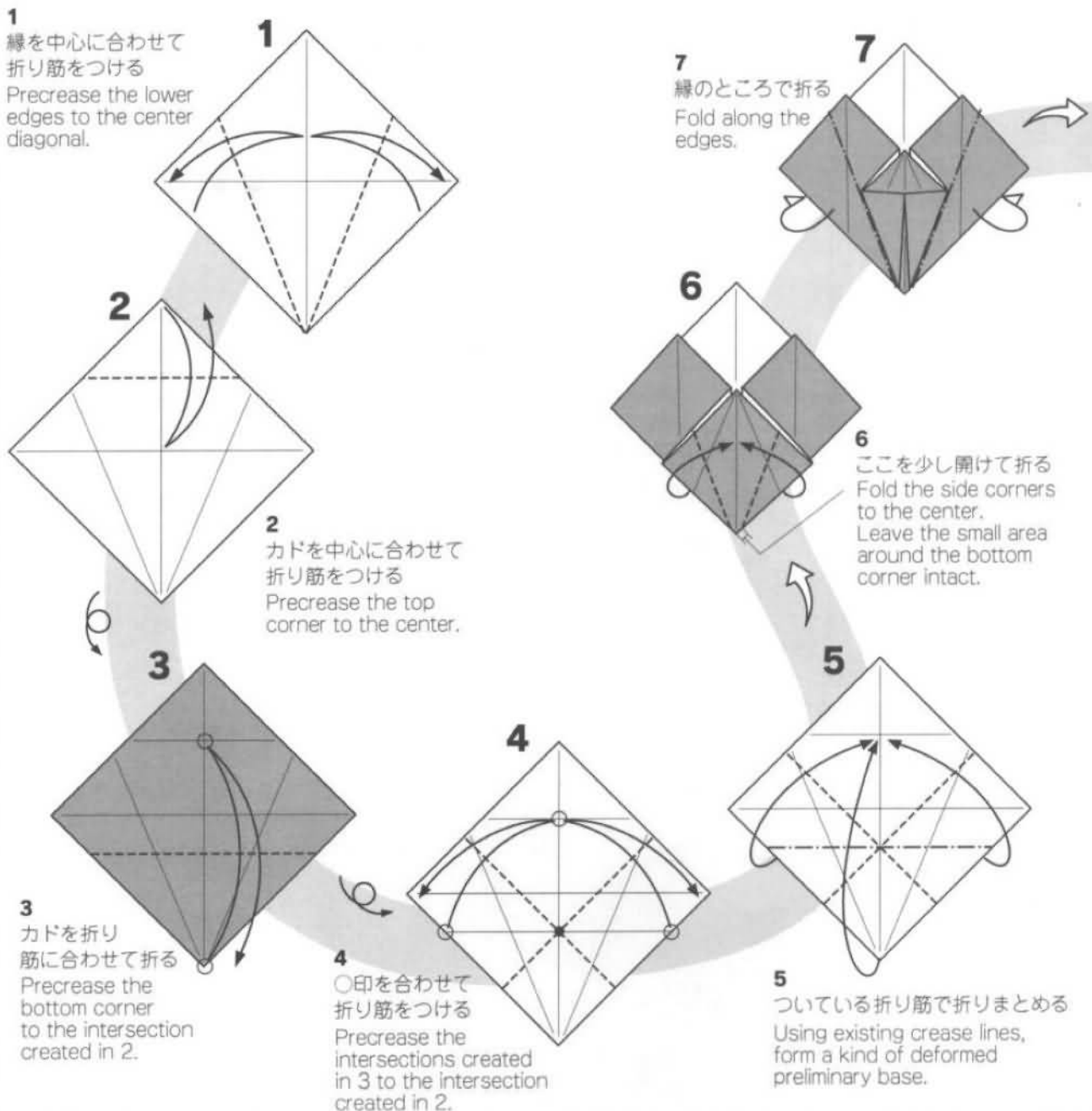

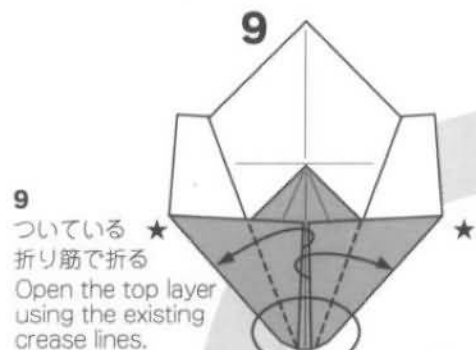

9 ついている★
折り筋で折る
Open the top layer
using the existing
crease lines.

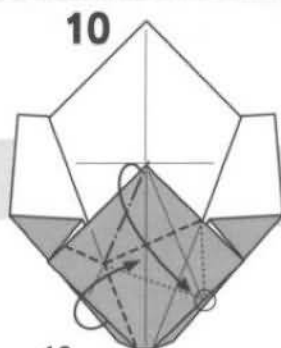

10 カドをつまんで線に
合わせて引き寄せる
ように折る
Swivel down the top
colored corner to the
existing intersection.
Using the existing
crease lines, close the
pulled-up layer.

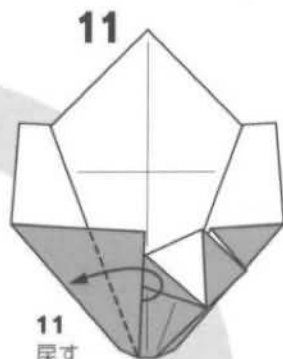

11 戻す
Unfold.

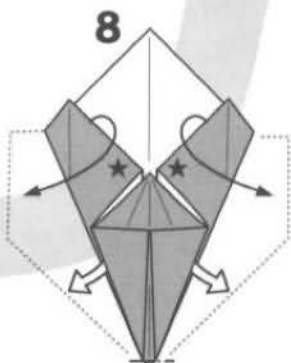

8 内側のカドを引き出す
Pull out the lower layers.
Spread sink the
bottom corner.



拡大図
The enlarged view.

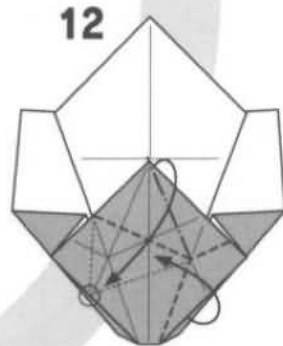

12 反対側も同じ
Repeat on the
right.

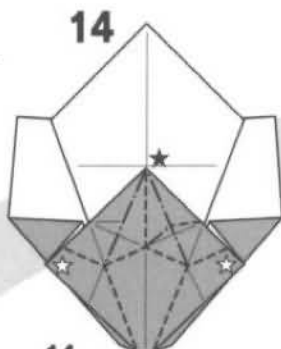

14 つけた折り筋を使って
カドをつまむように折る
Do the folds in 10 and 12
at the same time and close
the opening.
The top colored corner
will be swiveled down
and narrowed.

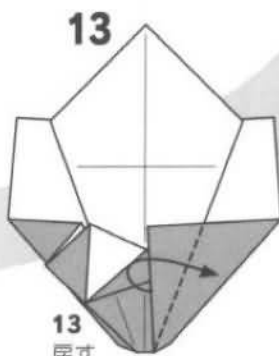

13 戻す
Unfold.

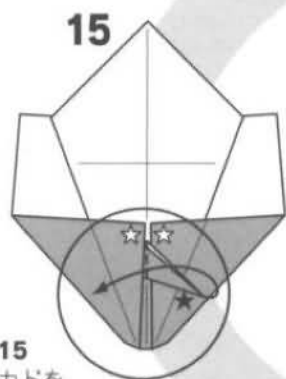

15 カドを
反対側に折る
Swivel the corner
to the left.

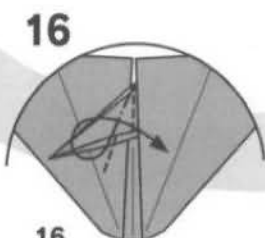

16 内側をひろげて
つぶすように折る
Open and squash.

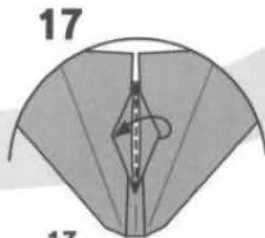

17 カドを反対側に折る
Swivel the corner
to the left.

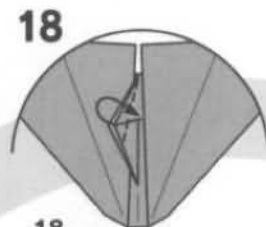

18 縁と縁を合わせて折る
Fold edge to edge.

28
開くところで折る
Open the layers
on the sides.

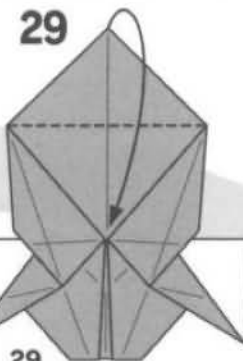
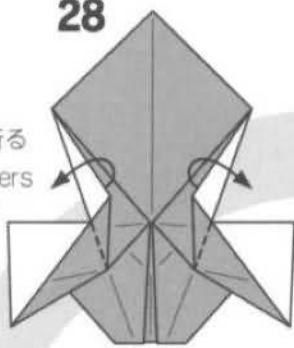

29
カドとカドを
結ぶ線で折る
Fold the top corner
to the intersection
at the center.

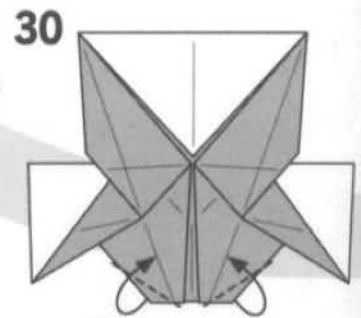

30
縁を折り筋に
合わせて折る
Fold the edges to
the crease lines.

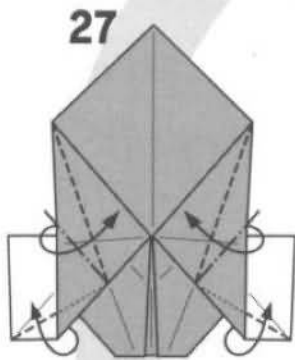

27
カドを細くするよう
につまんで引き寄せ
る
Narrow the upper
side corners and slide
the pulled-up layers.

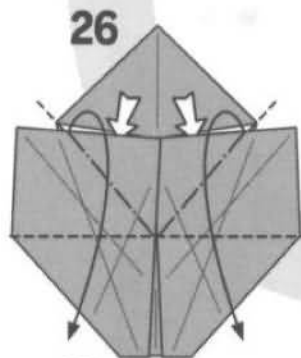

26
内側をひろげて
カドをつぶす
ように折る
Swivel down,
open and squash.

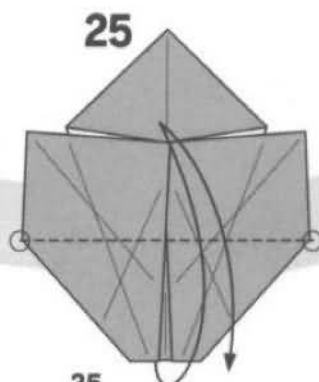

25
カドとカドを結ぶ線
で折り筋をつける
Precrease along the line
connecting the corners.

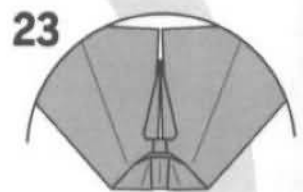
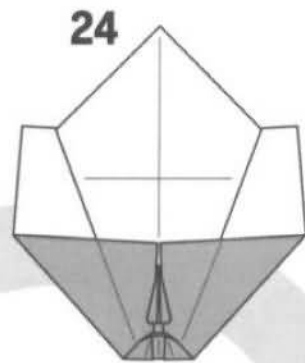

23

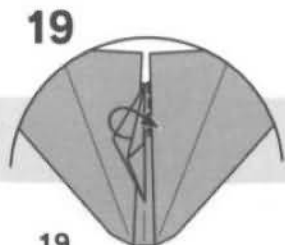

19
カドを反対側に折る
Swivel the corner
to the right.

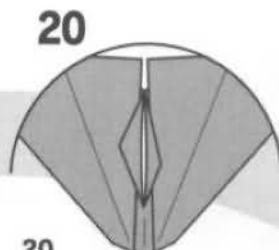

20
反対側も17~19と同じ
Repeat 17~19
on the left.

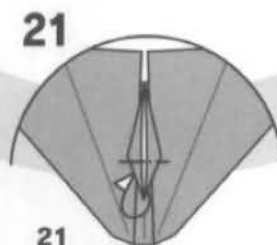

21
カドを後ろに折る
Mountain fold the
bottom corner of
the nose.

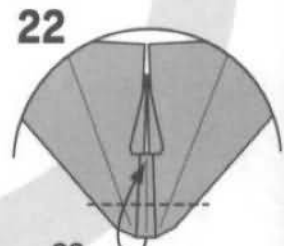

22
カドを上
に折る
Fold up the lower
jaw.

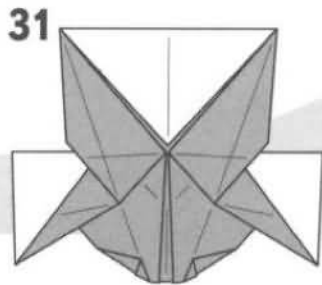

31

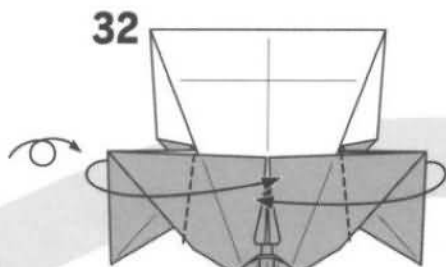

32

中心で重なるように折る
Close down so the side corners will overlap at the center.

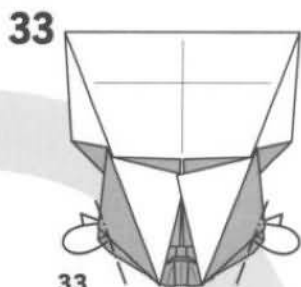

33

左右のカドを後ろへ少し折る
Mountain fold the side corners.

36
縁を目のあたりまで折る
Fold the side edges to the edge of the eyes.

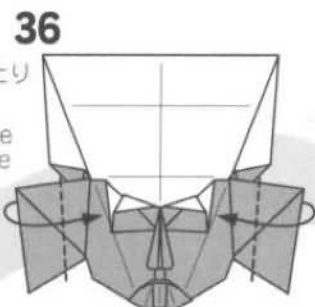

36

34
折ったカドの○のところから折る
Open up again starting from the circled intersections.

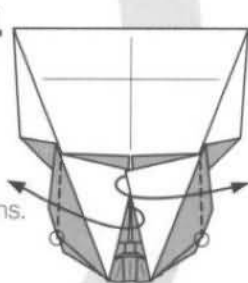

34

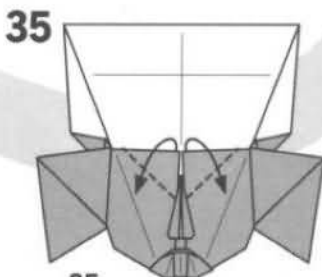

35

内側をひろげるように引き下げて折る
Open the top colored portions of the face.

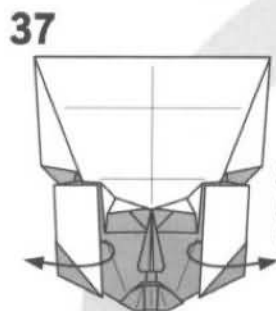

37

37
戻す
Unfold.

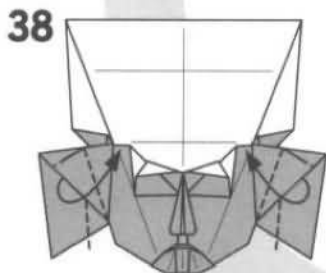

38

38
内側をひろげて引き寄せるようにしてつぶす
Open and squash.

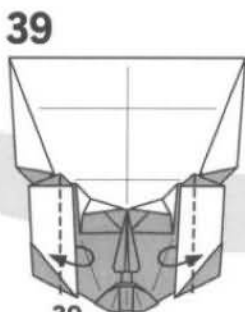

39

39
縁を少し折る
Valley fold the edges.

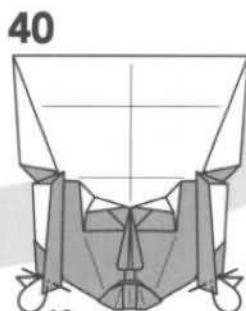

40

40
カドを少し後ろに折る
Mountain fold the corners.

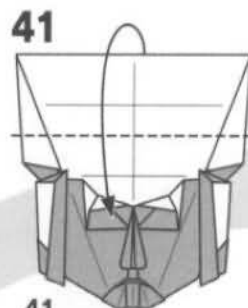

41

41
目の縁の少し上まで下に折る
Fold the top edge to slightly above the bottom edge of the eyes.

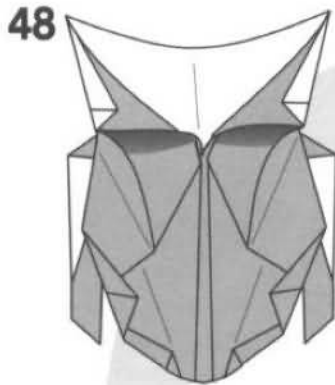

48

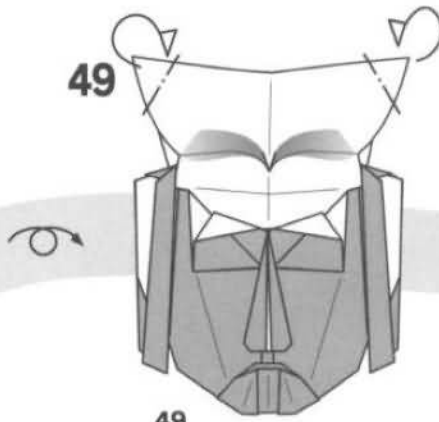

49

49
カドを少し後ろへ折る
Mountain fold the top
corners.

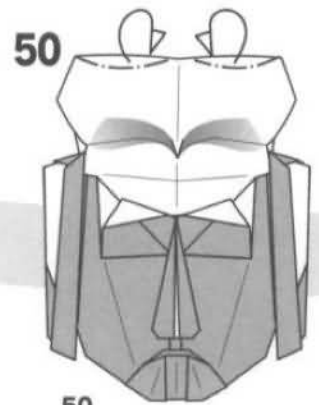

50

50
かるく折り筋をつけて
立体的にする
Giving crease lines on
the top will make the
top portion of the model
three-dimensional.

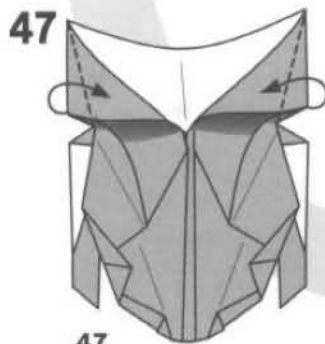

47

47
起こした部分のカドも
いっしょに折る
Fold the pulled-up
corners as well.

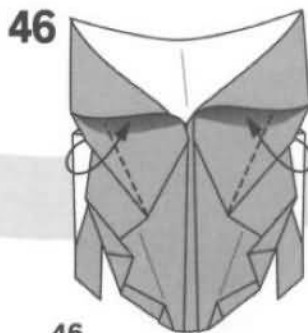

46

46
ついている折り筋で起こす
Stand up the layers using
the existing crease lines.



45

45
つまんだカドを片側に
倒して留める
Lock the corner pinched
in 42 by swiveling.

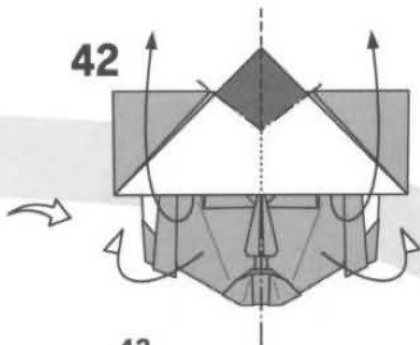

42

42
■の部分指でつまむように
折りながら頭の部分を
起こす
Pinch the darkened part and
raise the hair...

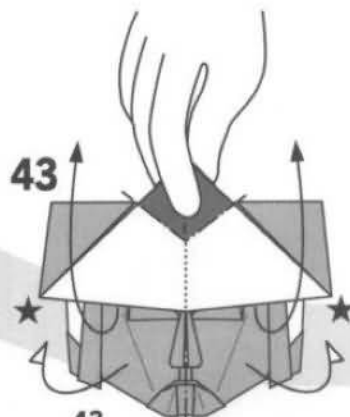

43

43
途中の図
顔は少し立体的になる
like this.
The face will be
three-dimensional.

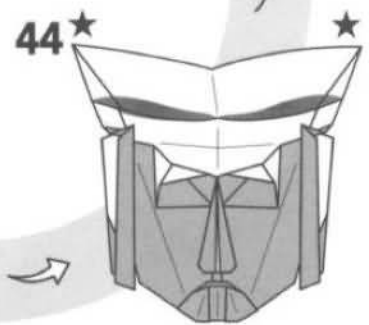

44★

51

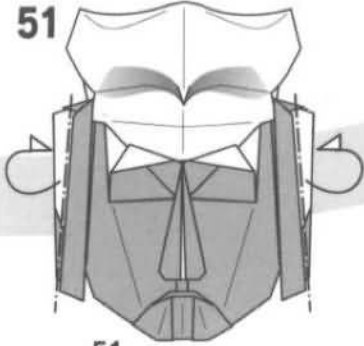

51
縁のところで折る
Mountain fold the edges.

52

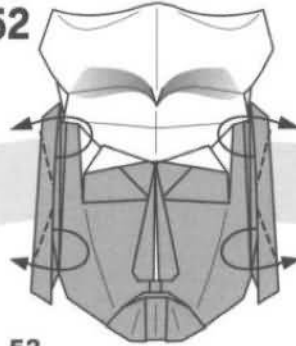

52
耳の上下をひろげるように折る
Open and shape the ears.

53

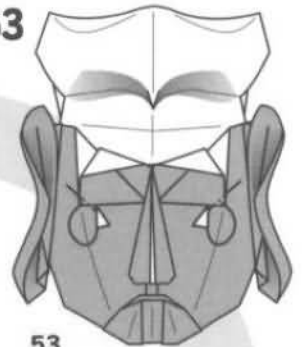

53
カドを少し後ろへ折る
Mountain fold the tips of the corners of the eyes.

54

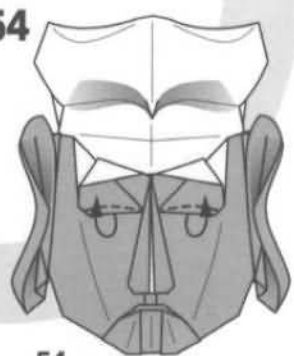

54
かるく折り筋をつけて
目の表情をつける
Shape the eyes giving
the crease lines.

55



55
鼻を立体的に立てる
Raise the nose.

56

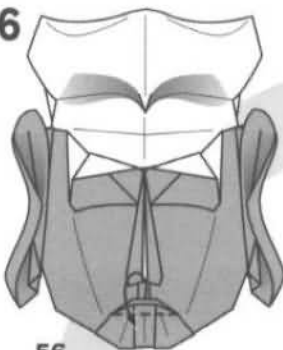

56
唇を軽くひろげて
表情をつける
Open the lips lightly.

57

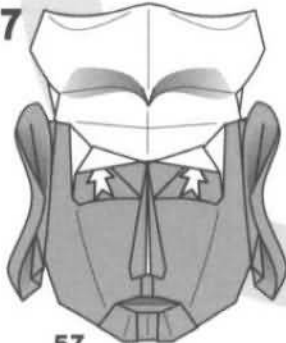

57
まゆの部分
曲面的に仕上げる
Shape the eyebrows.

58



できあがり
Model Completed

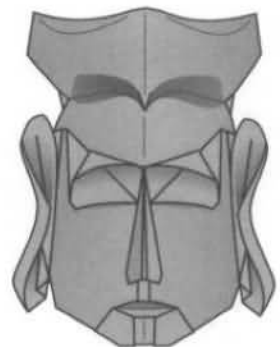

両面同色の紙で
折った図
With a sheet with the same
color on both sides.

ギャラリーおりがみはうすのご案内

日本で最初の折り紙作品専門展示場です。どなたでもご自由に見学頂けます。

東京都文京区白山 1-33-8-216 TEL/03-5684-6040 e-mail = info@origamihouse.jp

営業時間/10:00~18:00(日・祝休) website = http://www.origamihouse.jp/

雑誌『折紙探偵団』年間購読のご案内

雑誌『折紙探偵団』は日本折紙学会の機関誌です。隔月刊(奇数月25日発行)で年6回発行されます。年間購読制です(ばら売りは行っておりません)。

- 申込方法**
1. 郵便振替にてご送金下さい(普通の振替用紙でお申込み頂けます)。
 2. 振替用紙の「通信欄」に下記必要事項をご記入下さい。

第14期(2003年4月~2004年3月/79~84号)

年間購読費 3,600円(送料込み)

期変わりにより料金に変更になる場合があります。2004年4月以降は事務局にお問い合わせください

口座名 折紙探偵団

振替口座番号 00180-8-579860

記入必要事項 1~3は必ずお書き下さい。

1. 住所
2. 氏名 ※ふりがなをお願いします。
3. 電話、FAX番号
4. E-Mailアドレス
5. 性別
6. 生年月日
7. 職業

■バックナンバー購入について

現在10期~13期を取り扱っております。購入ご希望の場合は、「通信欄」のところへ希望する期を明記の上、相当金額をお振り込み下さい。

10期(55~60号)……3,000円(送料込み)、

11期(61~66号)・12期(67~72号)・13期(73~78号)……各3,600円(送料込み)

■雑誌『折紙探偵団』について

- ・『折紙探偵団』は日本折紙学会の機関誌です。購読には学会会員である必要はありません。
- ・隔月刊(奇数月25日発行)で年6回発行されます。
- ・年間購読のみ受け付けています。ばら売りは行っておりません。
- ・海外発送をご希望の場合は料金が異なります。事務局へお問い合わせください。
- ・折り図・展開図・折り紙研究・エッセイ・最新情報など充実の誌面です。

日本折紙学会 会員募集のお知らせ

日本折紙学会では、随時会員を募集しております。申込方法は定期購読と同じです。

会費には14期定期購読料も含まれています(すでに14期を購読されている方は4,400円となります)。

第14期会費8,000円 ※通信欄に「第14期会費」と明記してください

日本折紙学会事務局(10:00~18:00 日祝休)〒113-000東京都文京区白山 1-33-8-216
Phone/Fax 03-5684-6080 日本折紙学会ホームページ <http://www.origami.gr.jp/>



雑誌『折紙探偵団』79号表紙
表紙フルカラー/本文38ページ
(カラー口絵2ページ含む)

西川誠司作品集 2003年7月1日 発行

Printed in Japan

著者 西川誠司 ©Seiji Nishikawa 2003
編者 山口真
発行者 山口真
発行所 おりがみはうす 〒113-0001 東京都文京区白山1-33-8-216
tel: 03-5684-6040 fax: 03-5684-6080

■作品制作=西川誠司 ■編集=山口真 ■折り図=おりがみはうす ■デザイン・口絵写真=おりがみはうす(松浦英子)
■翻訳=立石浩一 ■表紙写真=佐藤 等

●Works of Seiji Nishikawa / Published on 1, July, 2003 by ORIGAMI HOUSE, 1-33-8-216 Hakusan Bunkyo-ku 113-0001 Tokyo JAPAN /
Model Designer : Seiji Nishikawa / Publisher : Makoto Yamaguchi / Editor : Makoto Yamaguchi / Editorial Design : ORIGAMI HOUSE /
Translator : Koichi Tateishi / Photographer (Cover) : Hitoshi Sato

本書の内容の一部あるいは全部を、無断でコピー、データファイル化することは、法律上での例外を除き禁じられています。

I ♥ ORIGAMI

Origami House Garage Book Series 7

Works of Seiji Nishikawa

Model Designer : Seiji Nishikawa

Editor : Makoto Yamaguchi

Translator : Keichi Tetsuchi



ORIGAMI HOUSE

¥3,200 (税別)