

ORIGAMI

Step by Step

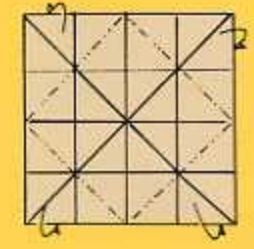

Robert Harbin

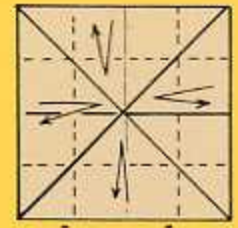
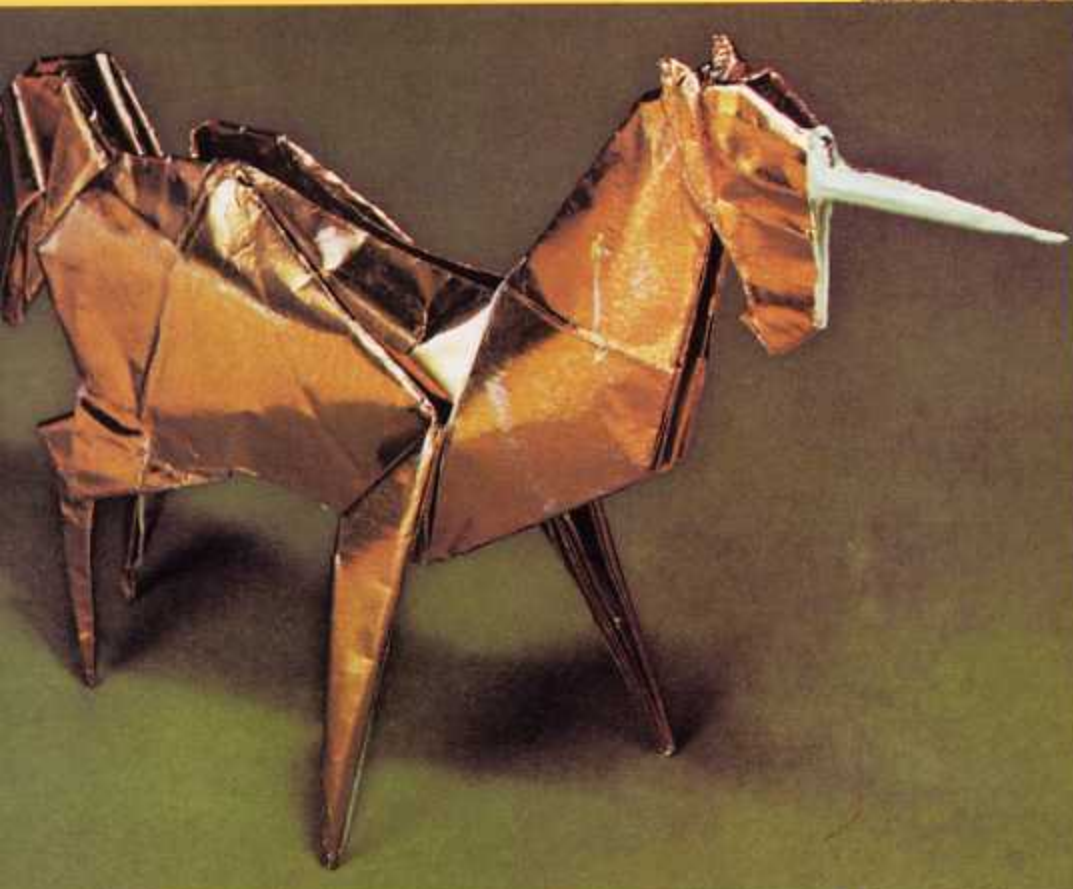
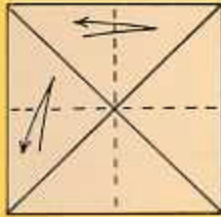
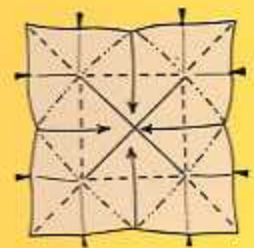
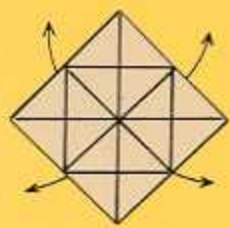

My grateful thanks to all those folders who have contributed models for this book, and especially Patricia Crawford of the United States of America, who has allowed me to illustrate so many of her remarkable creations.

Copyright

Copyright © 1974 by Robert Harbin
Copyright © 1998 by The British Origami Society
All rights reserved under Pan American and International Copyright Conventions.
Published in Canada by General Publishing Company, Ltd., 30 Lesmill Road, Don Mills, Toronto, Ontario.

Bibliographical Note

This Dover edition, first published in 1998, is an unabridged, slightly amended republication of the text and diagrams from *Origami: A Step-by-Step Guide*, first published in Great Britain in 1974 by The Hamlyn Publishing Group Ltd. An updated bibliography and a revised index have been added.

Library of Congress Cataloging-in-Publication Data

Harbin, Robert, 1909-
Origami step by step / Robert Harbin.
p. cm.
Rev. ed. with updated bibliography of: Origami. 1974.
Includes bibliographical references and index.
ISBN 0-486-40136-7 (pbk.)
1. Origami. I. Harbin, Robert, 1909- II. Title.
TT870.H318 1998
736'.982—dc21

98-10715
CIP

Manufactured in the United States of America
Dover Publications, Inc., 31 East 2nd Street, Mineola, N.Y. 11501

Contents

Introduction	4	"No Walk Today"	25
Before You Begin	5	Two Nuns	26
Symbols	7	Film Star	27
Flower	8	Octahedron	28
Japanese Box	11	Bellows	29
Water-Bomb Base	12	Stalking Cat	30
Church	13	Birdbath	32
Fancy Box	13	Squirrel on a Log	35
Salt Cellar	14	Birds in a Nest	39
Lover's Knot	14	Mermaid	42
Anvil	15	Christ on the Mount of Olives	45
Super-Box	15	Swan	47
Guillemot	16	Unicorn	49
Tetrahedron	18	Kangaroo	52
Decoration	20	Scorpion	55
Yacht	21	Full-rigged Ship	58
Speedboat	22	Stand for Ship	60
Dart	23	Bibliography and Organizations	61
Lakotoi	24	Index	63

Introduction

Origami is a Japanese word which means paper-folding. For many hundreds of years the Japanese have cultivated this art form.

During the past four decades origami has become a sophisticated Western pastime, and countless new models have been created in the United States, Great Britain, Europe, and the Latin American countries.

All you need is a piece of foldable paper and an idea in mind, and sooner or later something delightful will evolve.

Origami Step by Step will lead you gently into this old and very exciting world. If you manage to make every model described in this book you will indeed be a folding convert—one of the dedicated.

If origami is something new for you it is essential that you begin at the beginning. On no account must you try the difficult folds before you have completed some of the more simple models and begun to understand what the hobby is all about.

This book features a collection of remarkable folds by Patricia Crawford of the United States. Her folds are complex and in some cases quite difficult to do . . . but be assured you can, with a little concentration, get just as good a result as the creator herself.

Origami is not meant to be easy. Origami is a challenge and it is possible that some time will pass before you solve all the problems I have laid before you.

If you are already a keen paper-folder, then you will be very excited when you find just how many new and wonderful folds there are in these pages.

Although I have tried to put as much detail as possible into the illustrations, and provide as many step-by-step drawings as possible, a great deal is left for you to discover from the signs, symbols, and a few helpful words.

Before You Begin

Symbols

The symbols are based on Akira Yoshizawa's code of lines and arrows. The first thing to do is to study and remember the symbols. Once you get these signs and symbols well into your head, following the step-by-step illustrations will be no problem for you.

Each drawing really tells its story. Examine the symbols carefully, and immediately you should know what to do. However, in many cases a few words of explanation have been inserted here and there. These should not be necessary, but may help a beginner.

The symbols are self-explanatory. The little arrows tell you just what to do. One arrow means fold in front, another fold behind, and yet another fold under or into and so on.

Most books on origami adopt a set of symbols very like the ones in this book, and if there are differences you will soon see just what they are.

The first few pages contain several simple folds which will give you as much practice as you need to tackle the more advanced folds.

Try to read the symbols and *see* in your mind just how a fold must be made.

So . . . for ten minutes, study those symbols.

Precreasing

This means that in order to make the model easier to fold, a certain amount of preliminary creasing is necessary. Once these essential creases have been made it is then comparatively simple to arrive at the correct result.

Patricia Crawford's "Bird Bath" is a typical example of detailed precreasing. Once the creases have been made the rest of the folds are fairly simple.

When precreasing, it is necessary to find some guide lines and wherever possible these have been given, so that when the first few folds are made other guide lines are automatically created, and so on until all the folds have been made.

Procedures

In origami there are several standard procedures which you may or may not already know. In the early pages you will notice that certain procedures are shown in detail. For example: on page 11 you will see in Figs. 1 to 10 that flaps are lifted and pressed flat—they are "squashed." This will happen a number of times.

On page 10 you will see how to "sink" two corners, Figs. 24, 25 and 26: how first of all you precrease, then stretch out and "push in." This will happen again several times but not always in the same way: see pages 58–59, Figs. 6, 7, 8 and 9 and so on.

The "Petal-fold" is always being used: see page 9, Figs. 10 to 19. Petal-folds need not always be exactly this shape but the procedure is always the same.

If you come across a written instruction to do this or that or the other and you don't know just what is meant, take a look through the index and see where an example of this fold occurs.

"Reverse-folds" will play a big part in your life. "The Guillemot" is a working example of a series of reverse-folds: inside reverse-folds and outside reverse-folds. In this case precreasing helps, as you will clearly see.

As you work your way through this and other origami books you will become familiar with procedures, and after a while they will become second nature.

Bases

There are many bases: traditional bases and bases created by folders. The Preliminary Base, page 8, the Waterbomb Base, page 12, the Bird Base, page 9, are a few of the many you will come into contact with.

Most creative folders have bases from which they make many folds. Neal Elias and Fred Rohm of the USA are examples of this. Fred Rohm has what he calls his Simplex Base, from which countless folds have been made, especially working models.

In this book you will notice that the "Mermaid," "Christ on the Mount of Olives," and the "Squirrel on the Log" all begin in much the same way.

The Bird Base, the most famous of all traditional bases, has been most used. Then there is the Stretched Bird Base, the Blintzed Bird Base, and so on. Sometimes two bases are mixed together; you will begin to recognize them and probably invent a couple of your own.

Once you are familiar with some of these beginnings you will be able to create your own models. The most popular first creations are some sort of bird, a decorative design, or a box, and then—who knows?—something bigger and better.

So watch out for, and become familiar with, the bases.

Paper

Almost any paper will do, but fine papers make fine models. Do not just tear a piece of paper out of a school notebook and expect to make a neat and attractive model.

If you need a square it must be exactly square; if a triangle or a rectangle the measurements must be exact, otherwise the resulting model will be a monstrosity.

Papers specially made for origami can be found in many shops, and all attractive wrapping papers cut to size are ideal. You will notice that Patricia Crawford uses foils. These metallic papers keep good shape and are in some cases essential for the models described.

HOW TO USE THE SYMBOLS Making a flower

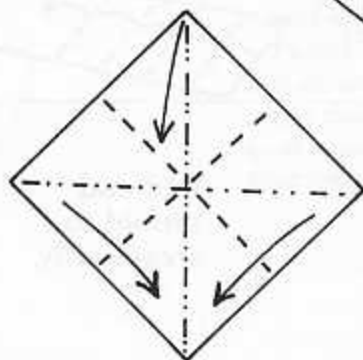
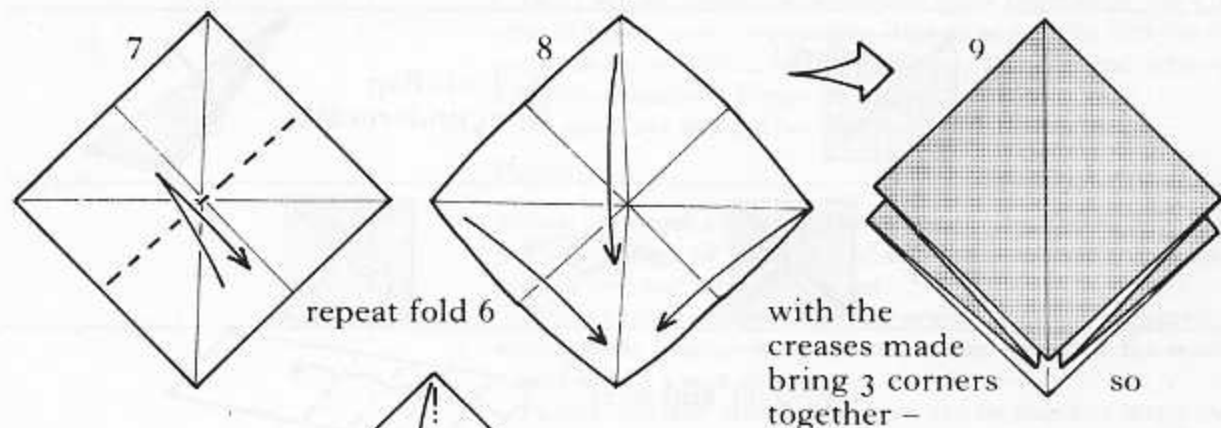
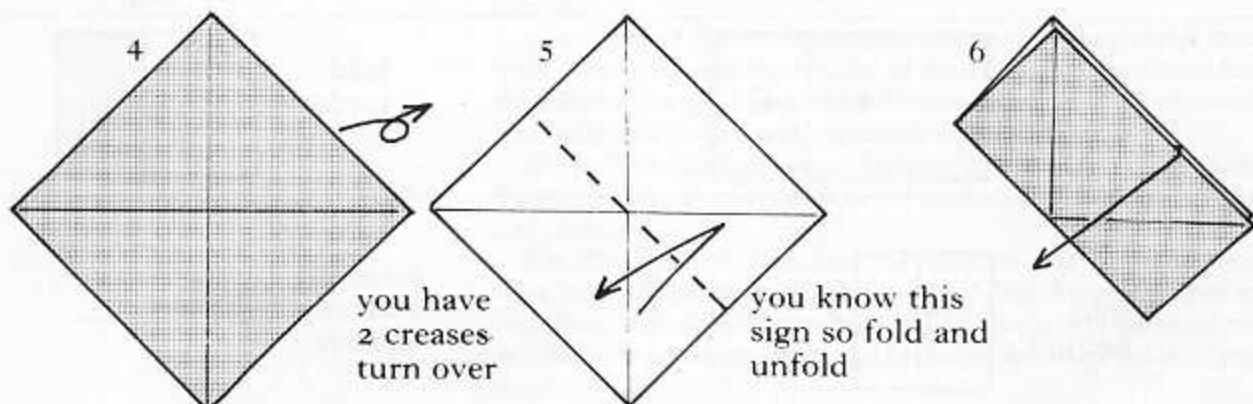
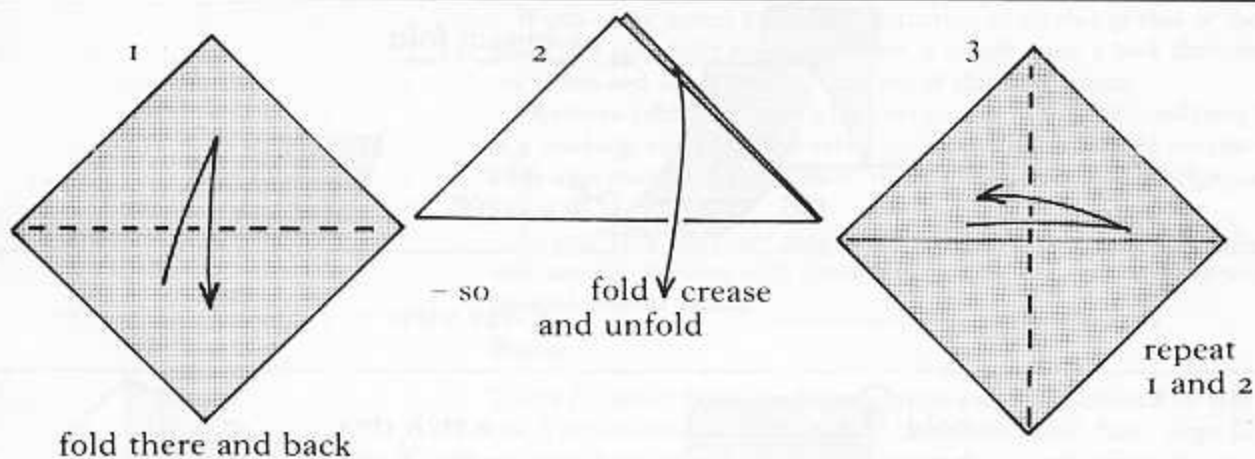

when you see a square marked like this, make the folds 1 to 9 and you have a PRELIMINARY BASE

USE OF SYMBOLS Making a flower (continued)

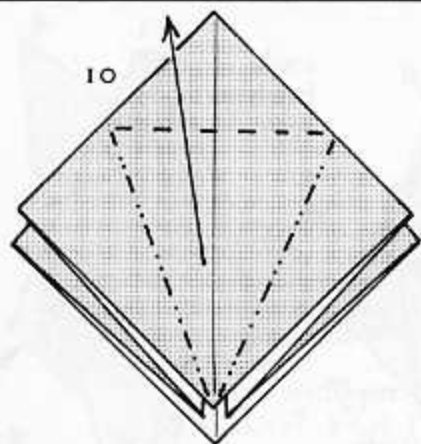

10
this combination of symbols indicates a PETAL FOLD explained step by step in figures 11-18.

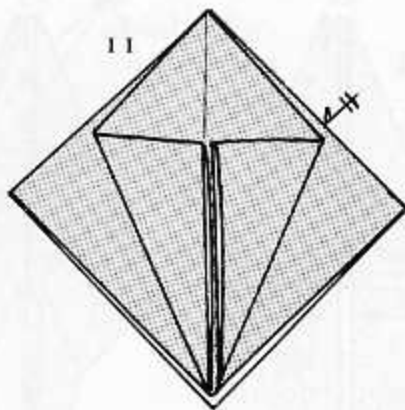

11
first crease with valley folds repeat behind

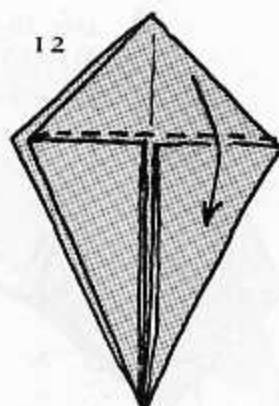

12
now crease the top triangle or flap

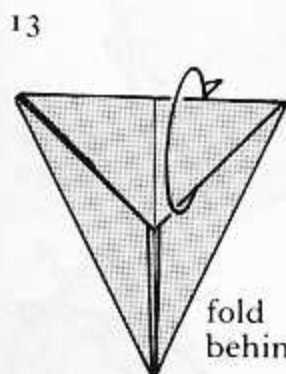

13
fold behind

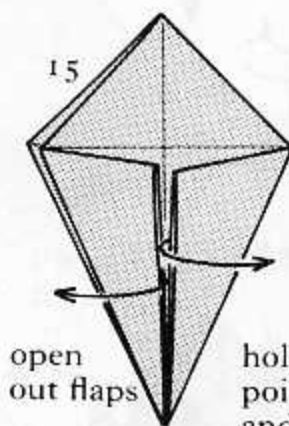
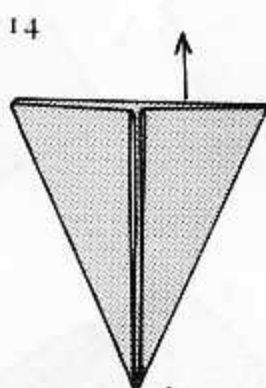

14
open out flaps

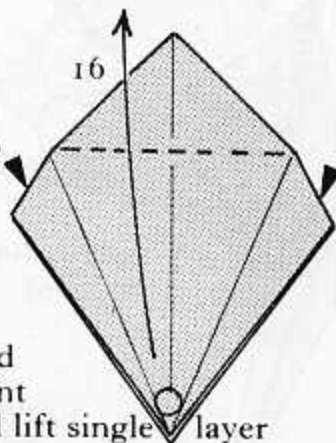

15
hold point and lift single layer

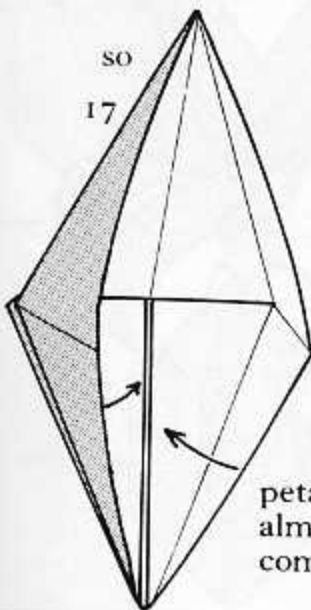

16
17

petal fold almost complete

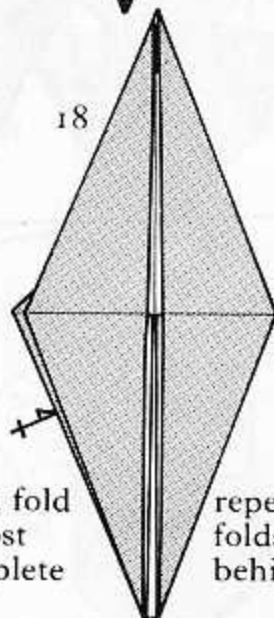

18

repeat folds 16 to 18 behind

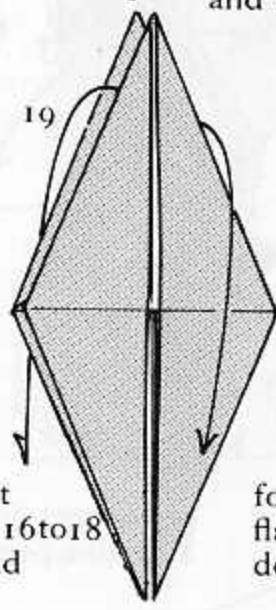

19

fold flaps down

this is a BIRD BASE

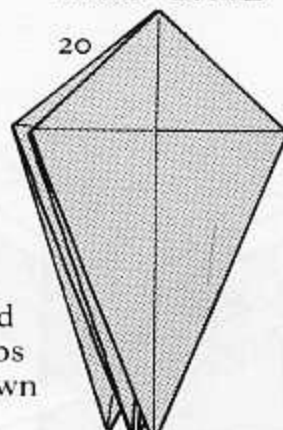

20

Making a flower Philip Shen Hong Kong

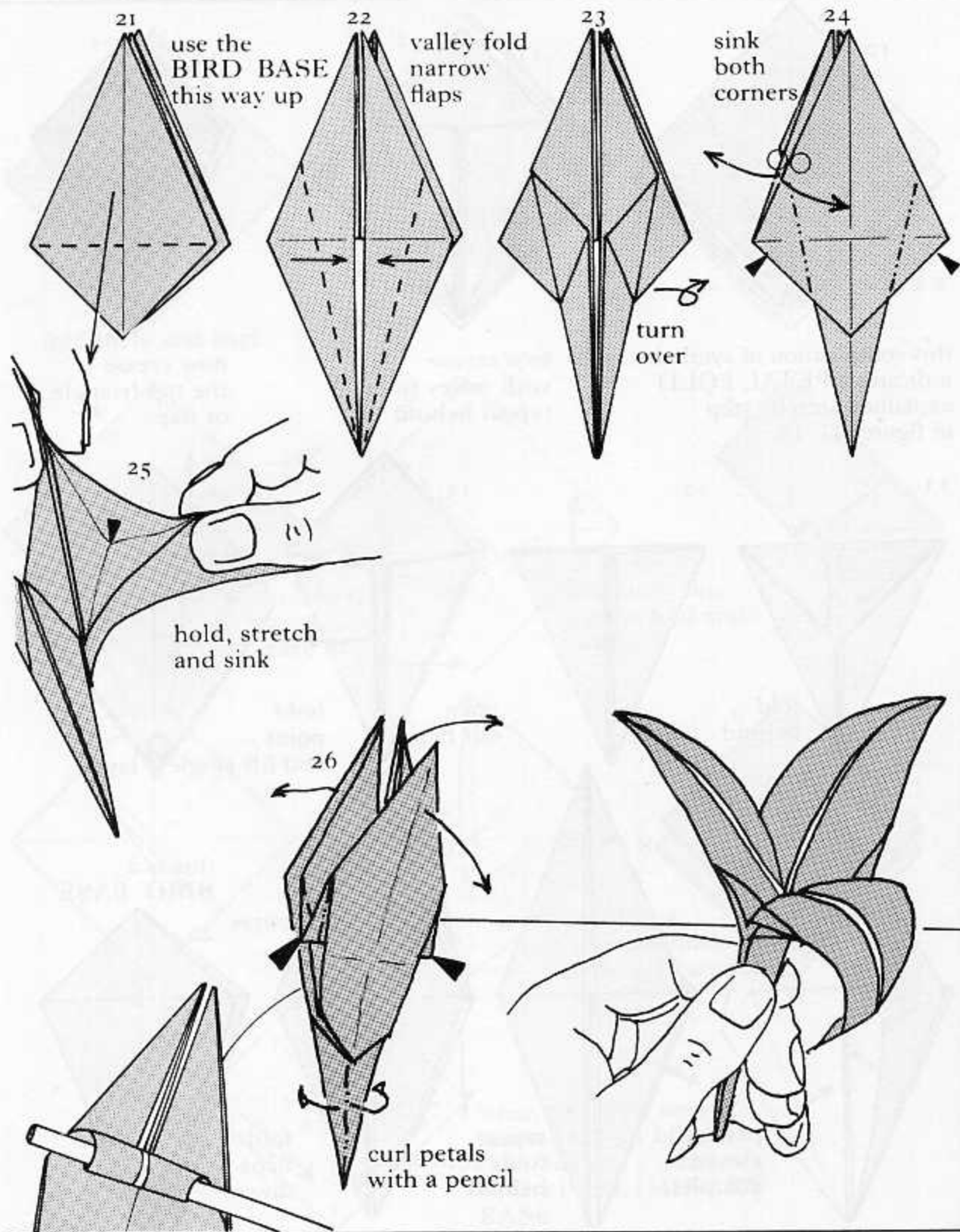

USE OF SYMBOLS Japanese Box

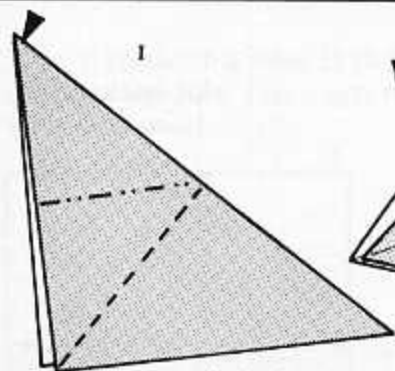

1
symbols indicate
SQUASH FOLD

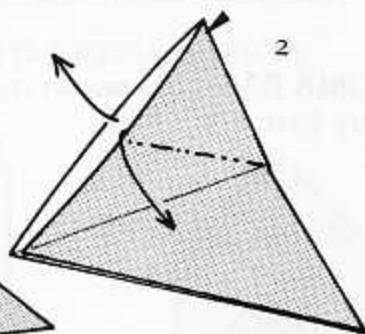

2
raise point;
open out squash

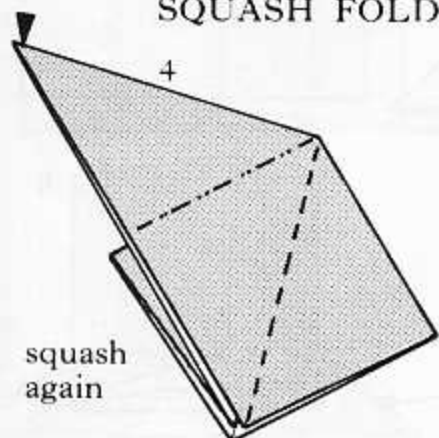
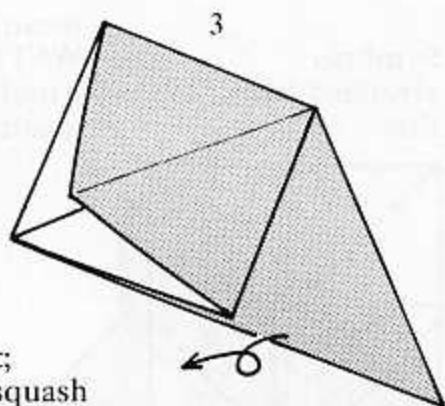

4
squash
again

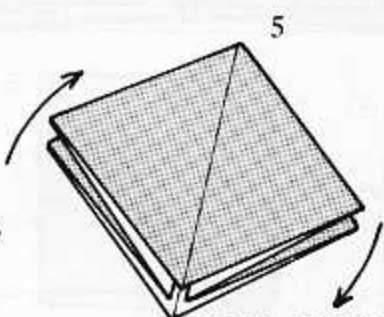

5
PRELIMINARY
BASE

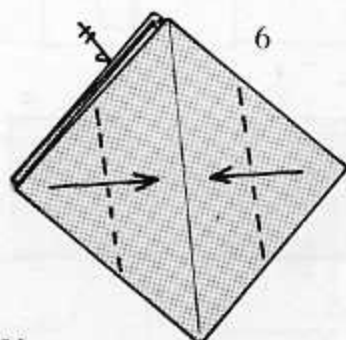

6
repeat
twice

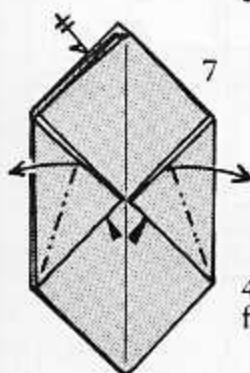

7
4 squash
folds

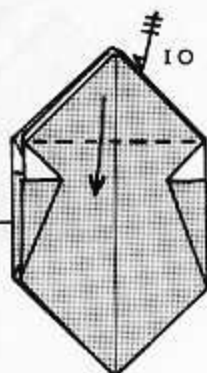
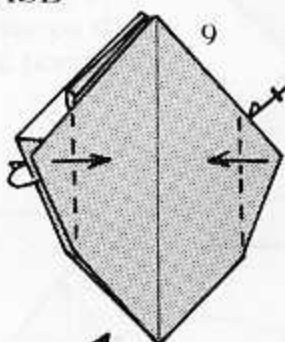
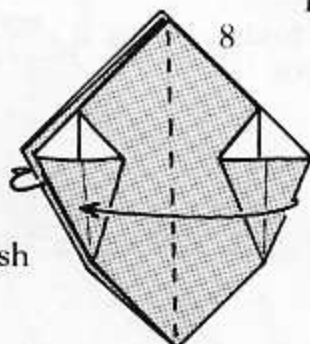

10
repeat
3 times

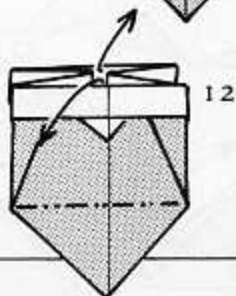
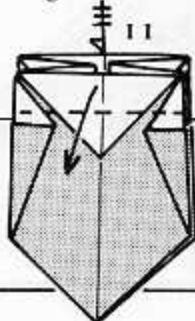

12
crease
only

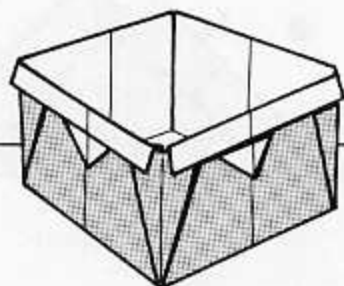

USE OF SYMBOLS Waterbomb Base

Symbols arranged like this—

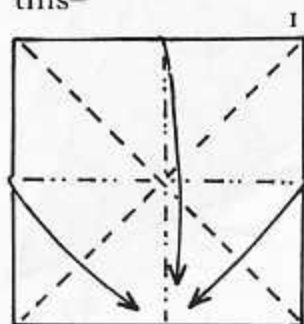

— mean the WATERBOMB BASE below.
a preliminary base inside out.

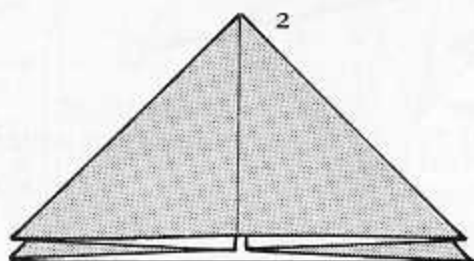

— or make the base this way

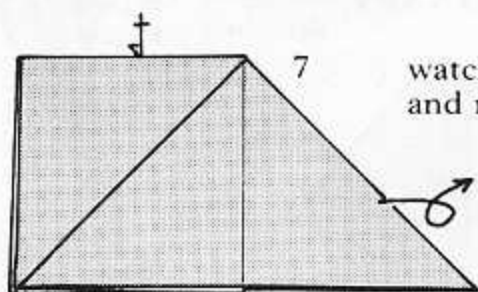
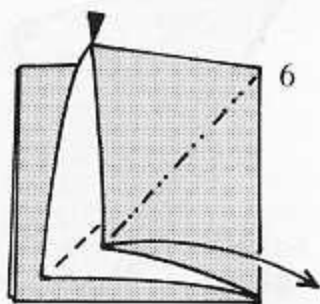
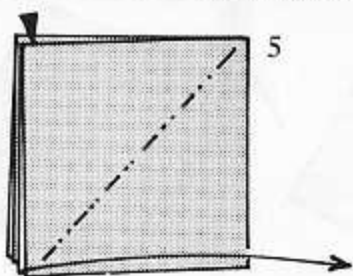
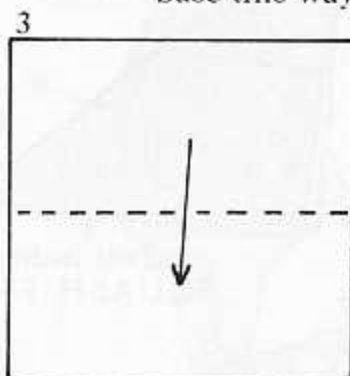

watch squash folds
and repeat signs

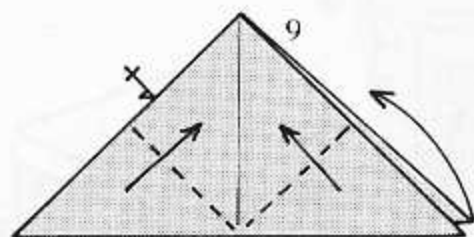
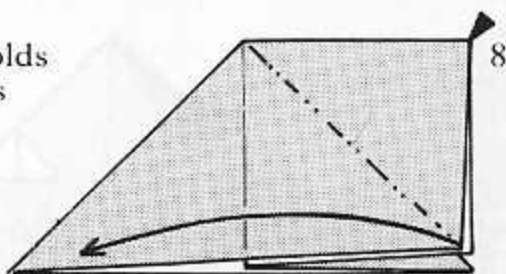

four squash
folds

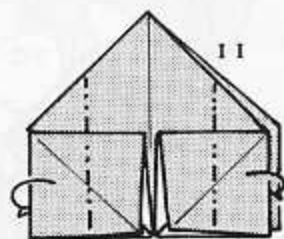
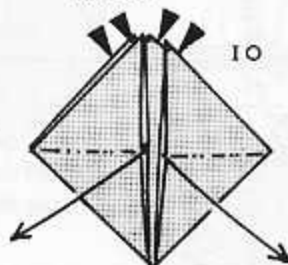

USE OF SYMBOLS Church and Fancy Box

The waterbomb base is the starting point for endless models. Here are two.

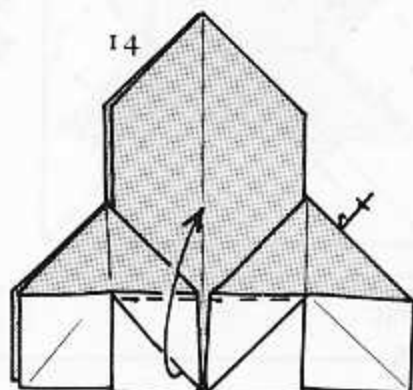
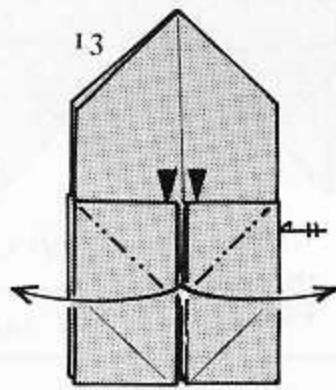
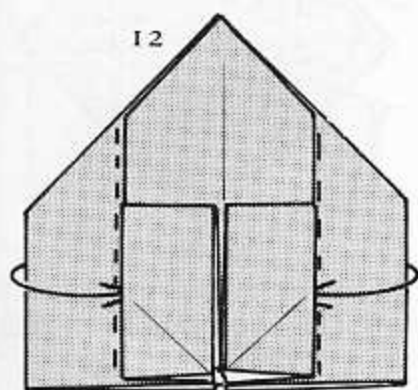

begin with
fold 11 (page 12)

petal fold
4 times (page 9)

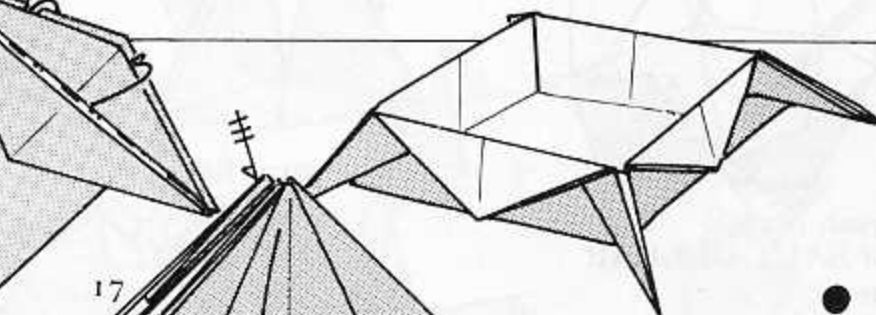
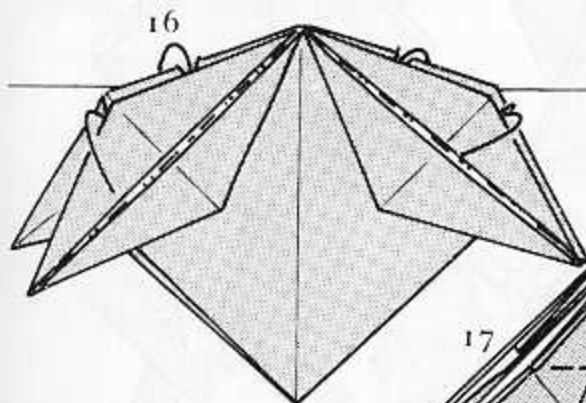
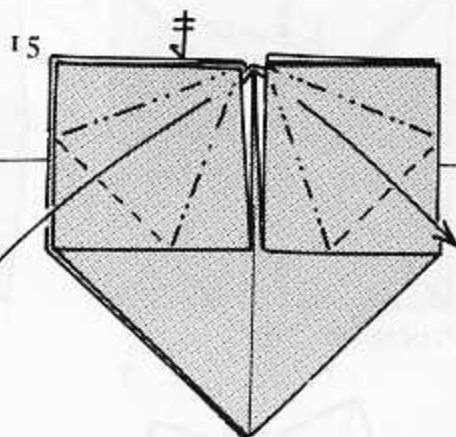

this box can
be made from
the
WINDMILL BASE
(page 20)

Lover's Knot—Traditional *An exercise*

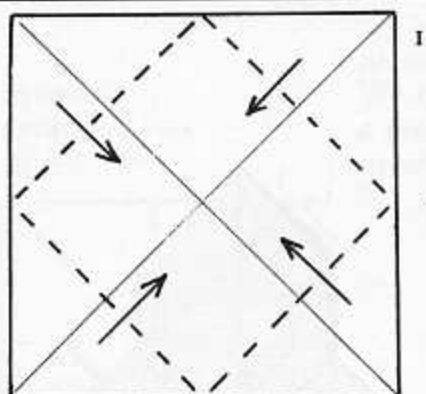

crease diagonals
first

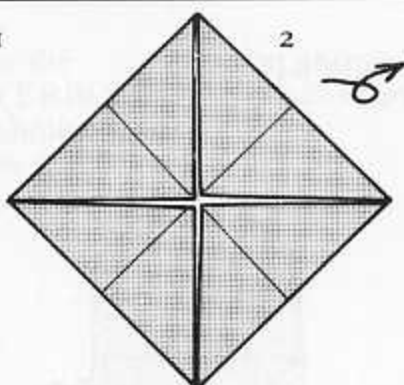

this is a BLINTZ
FOLD

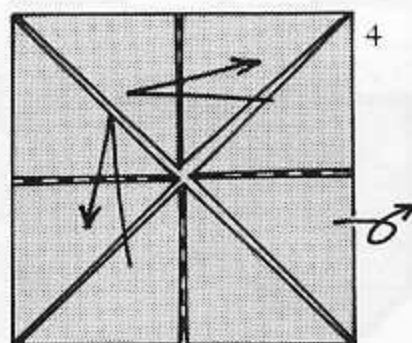
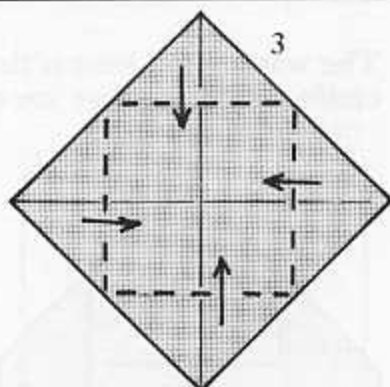

Precrease

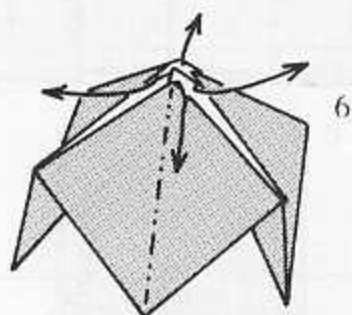
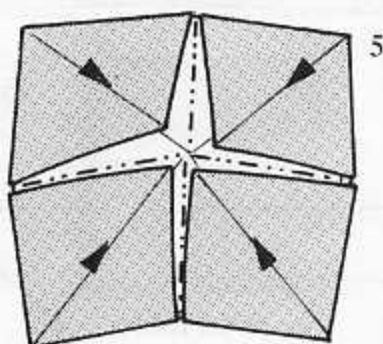

open out
4 flaps

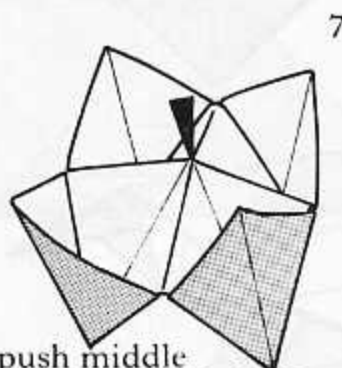

push middle
of SALT CELLAR
in-

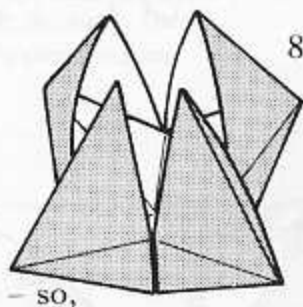

- so,
press flat

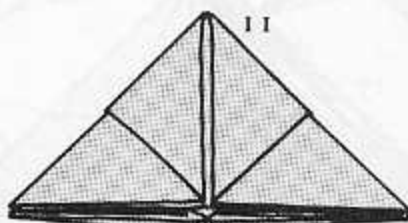
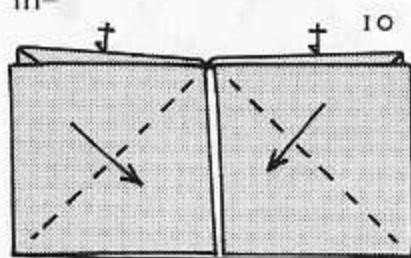
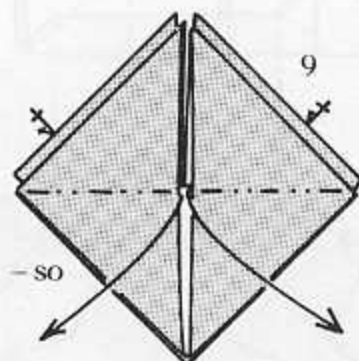

insert thumbs
either side
of X

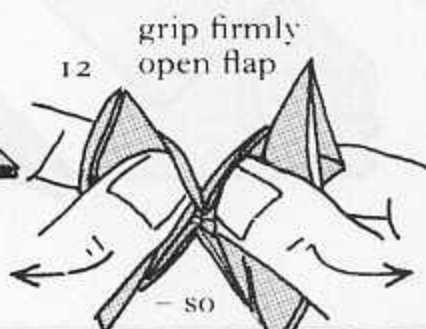

grip firmly
open flap

- so

Lover's Knot (continued)

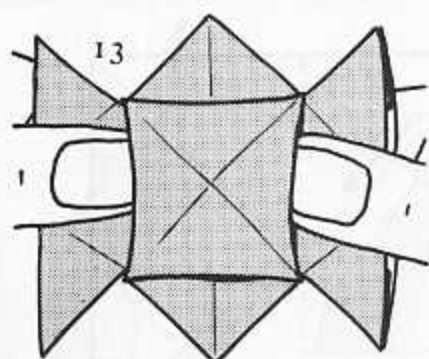

- and so

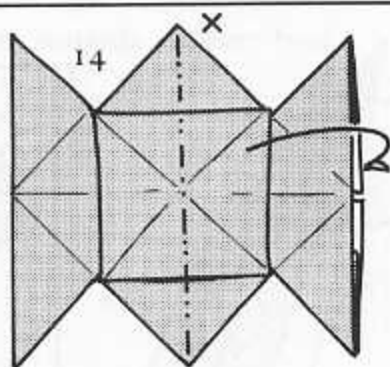

LOVER'S KNOT

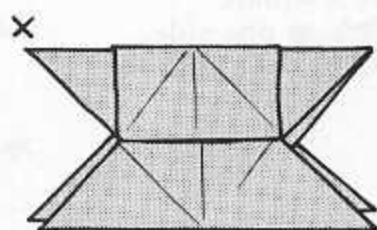

ANVIL

Super-Box John Richardson Gt. Britain

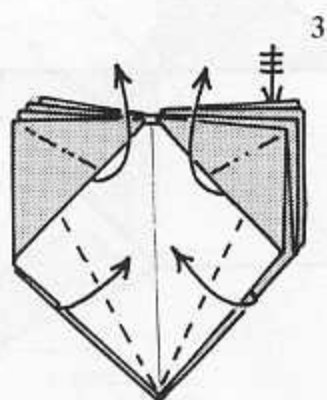
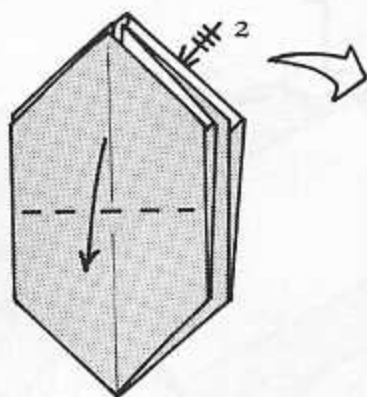
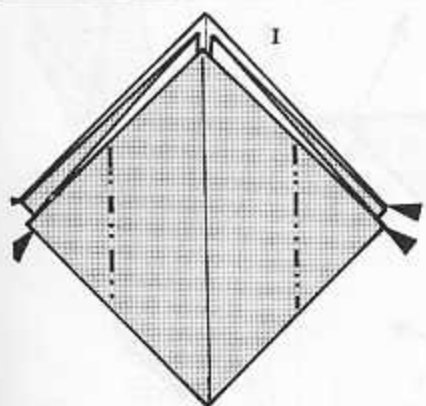

Begin with the preliminary base

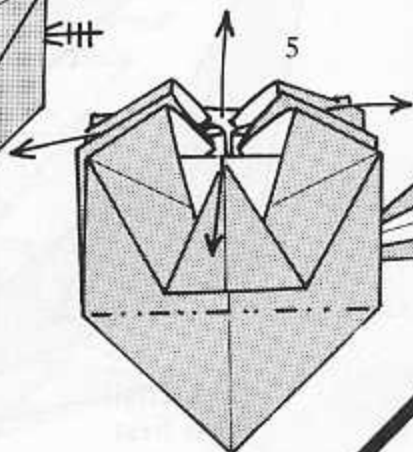
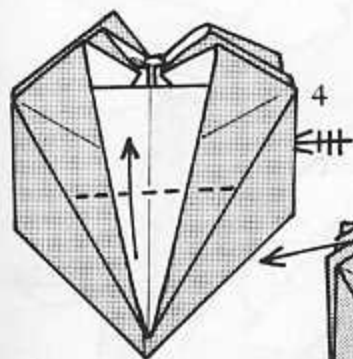

watch repeat signs

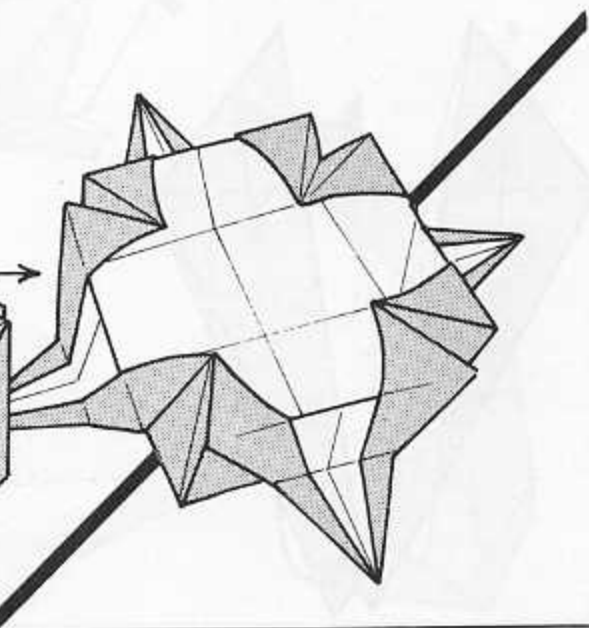

Use a square
black on one side.
Follow the symbols.

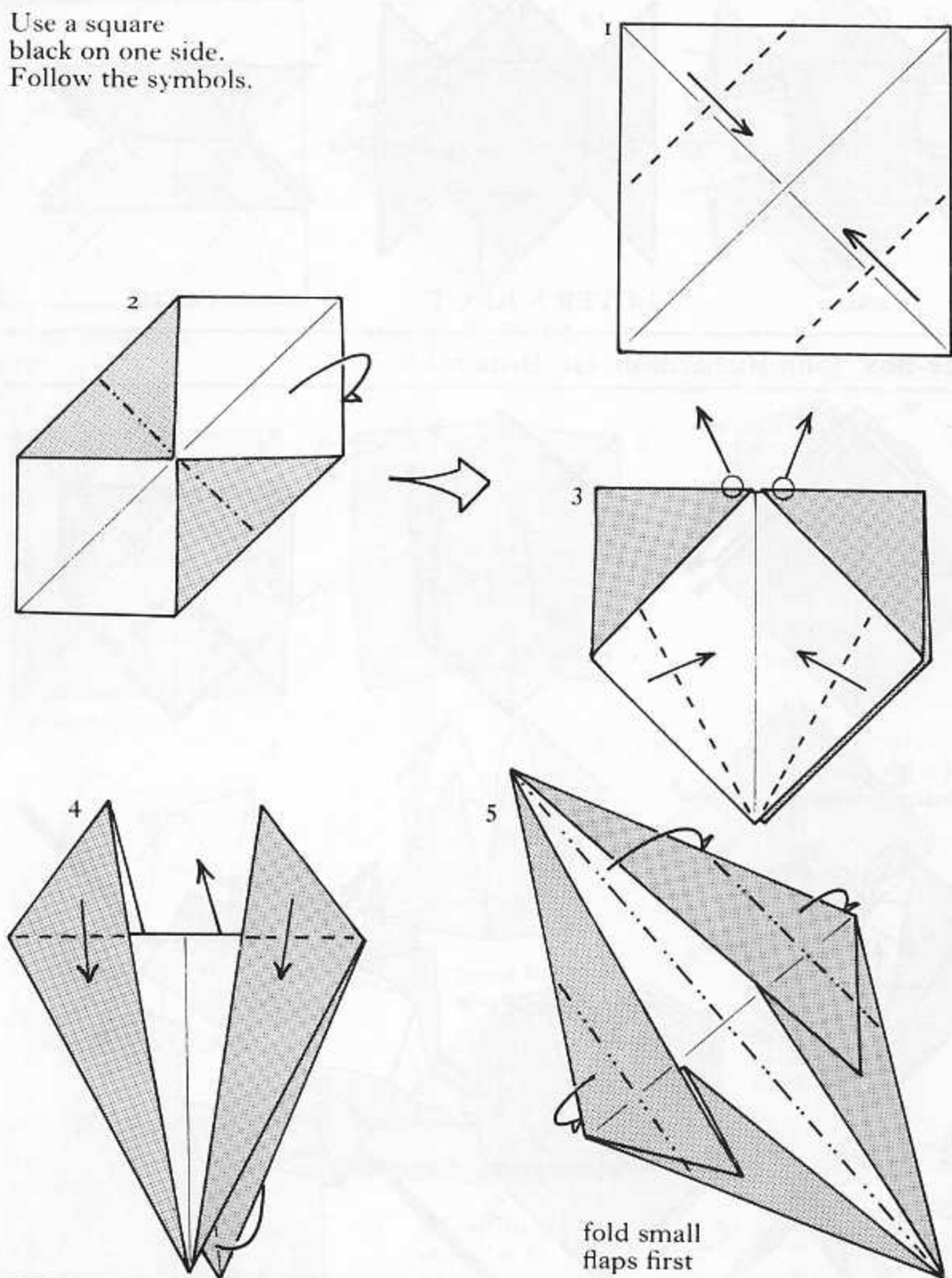

Guillemot (continued)

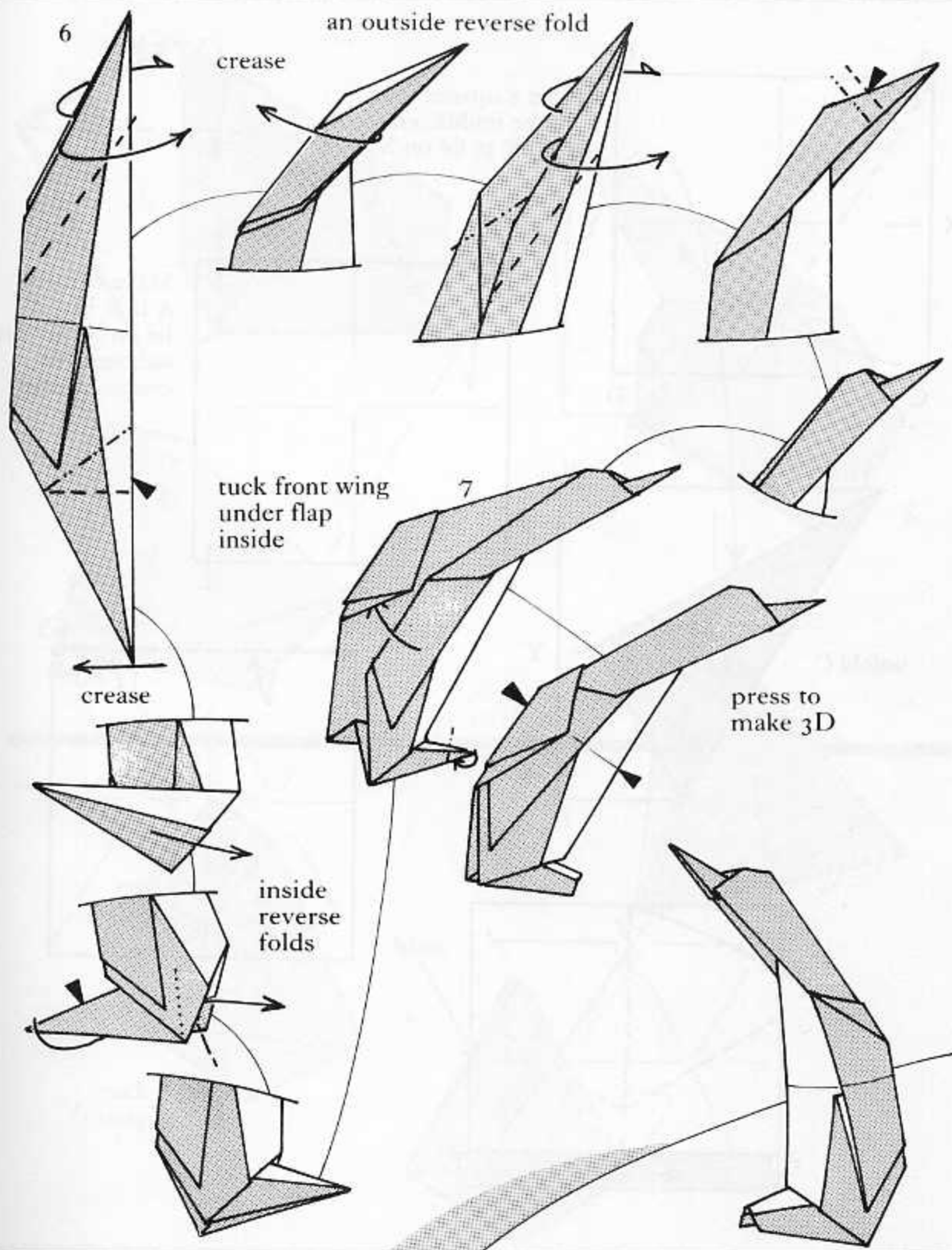

Tetrahedron (Geometric solid) Patricia Crawford U.S.A.

1

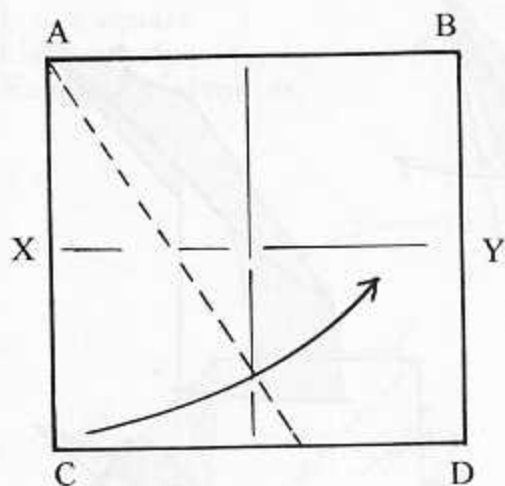

Use a square;
make middle creases;
fold C to lie on XY.

3

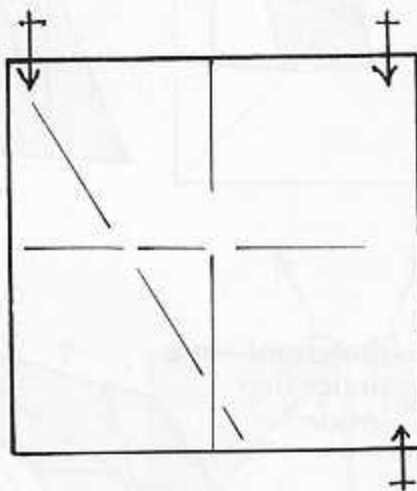

Make corners
A B & D
lie on XY in turn
to complete
crease pattern.

2

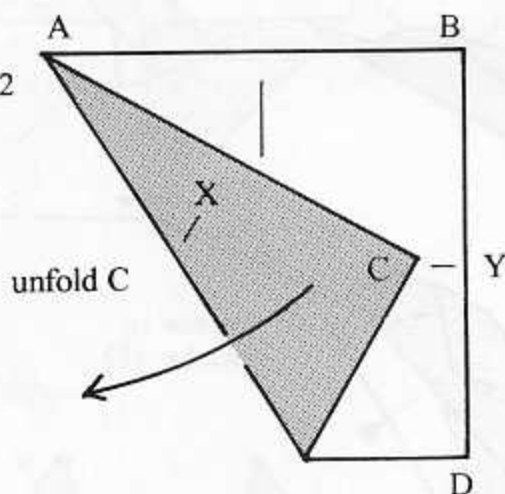

4

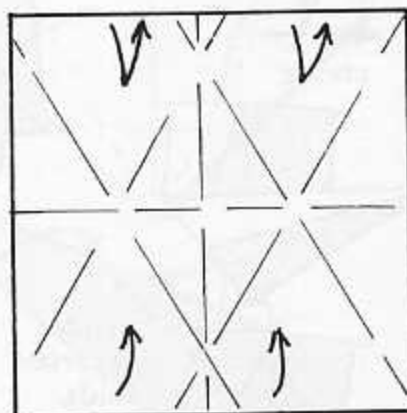

5

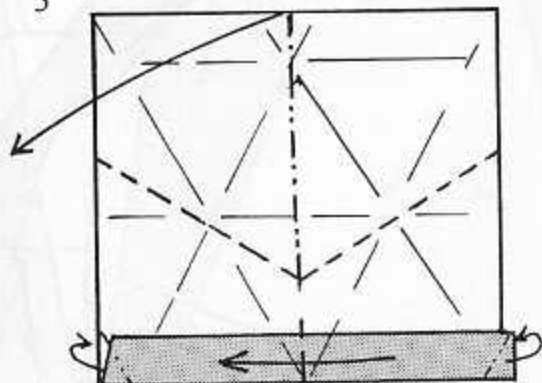

Tetrahedron (continued)

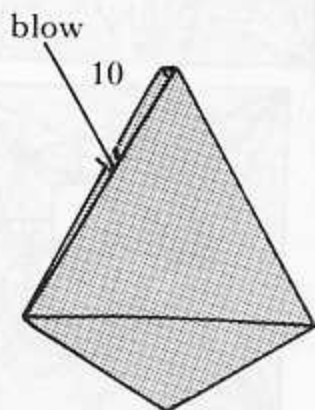
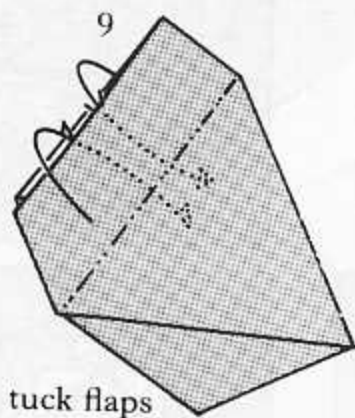
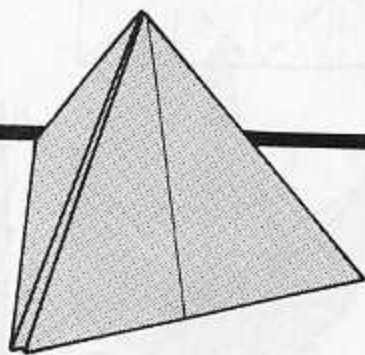
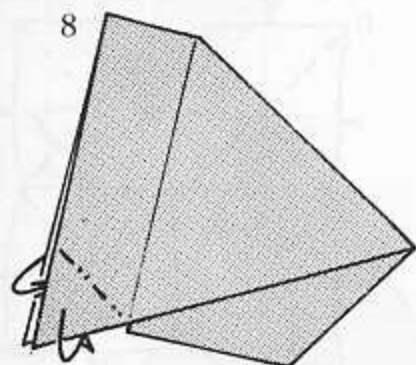
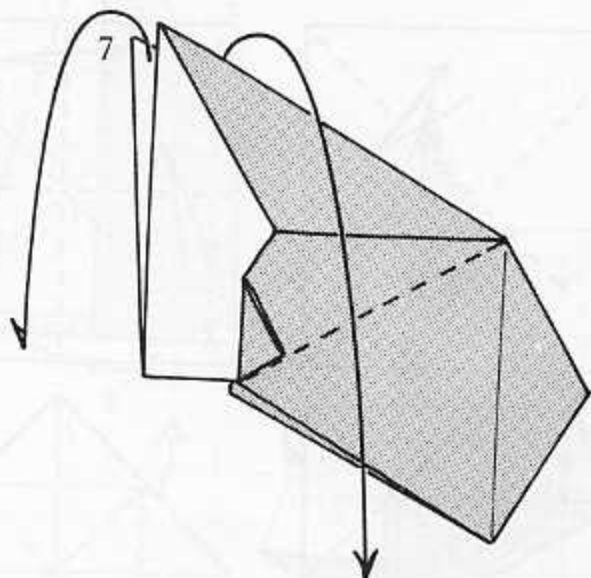
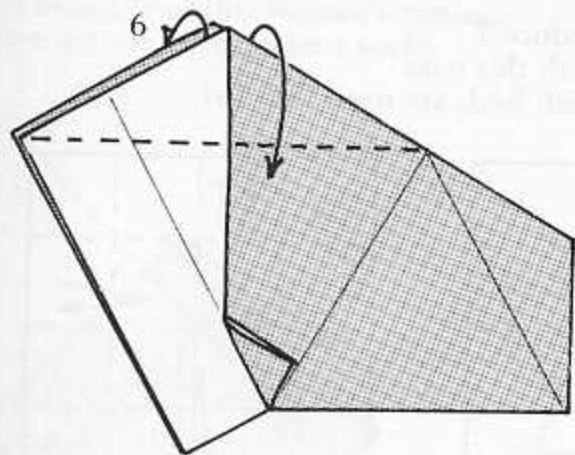

Decoration Folding exercise Japan

Use a square, either side up. Creases 1 to 5 produce 7.
Squash folds produce 8, the Windmill Base. With this base
endless decorative folds can be devised. 8 squash folds are used (fig. 10).

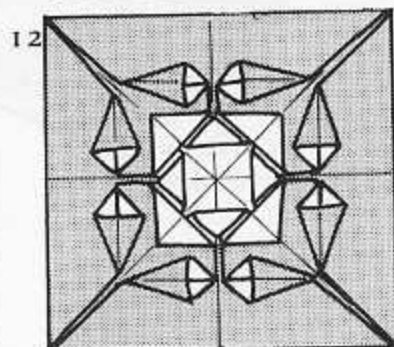
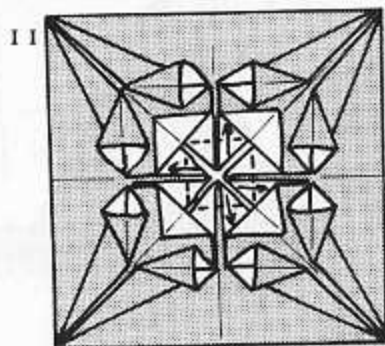
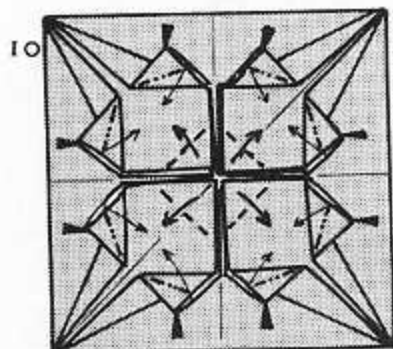
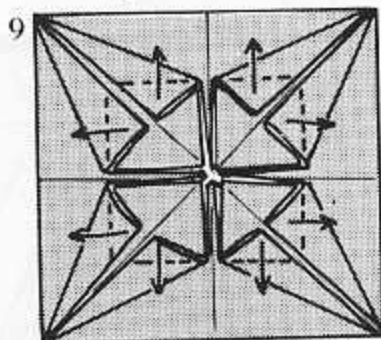
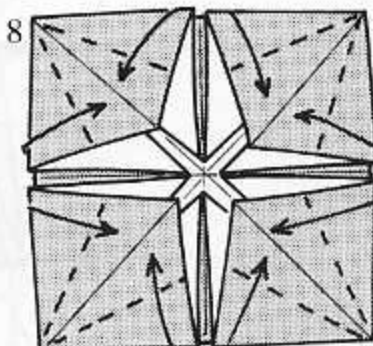
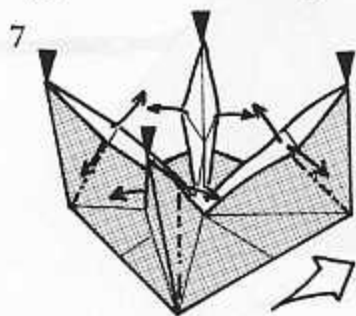
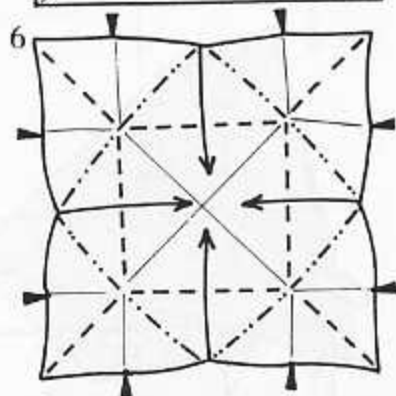
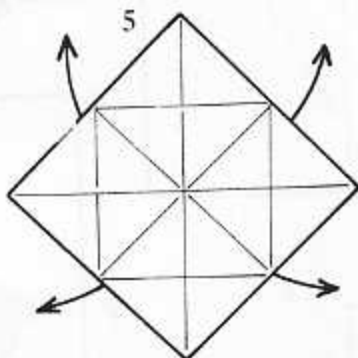
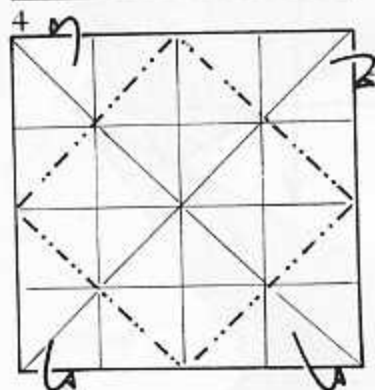
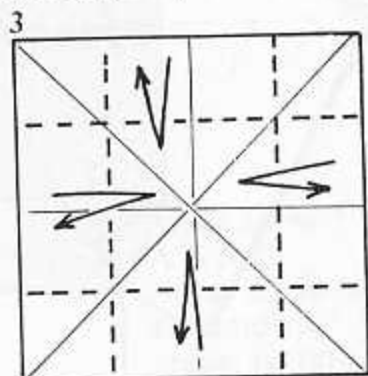
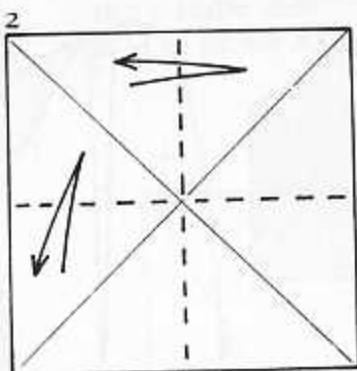
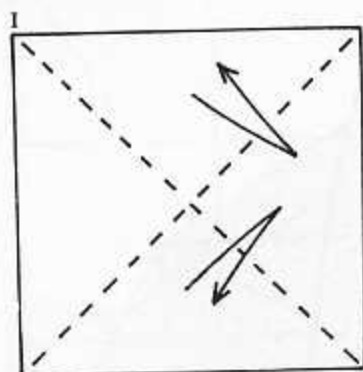

Yacht Toshie Takahama Japan

An example of this woman's genius.
Five simple folds make a yacht.

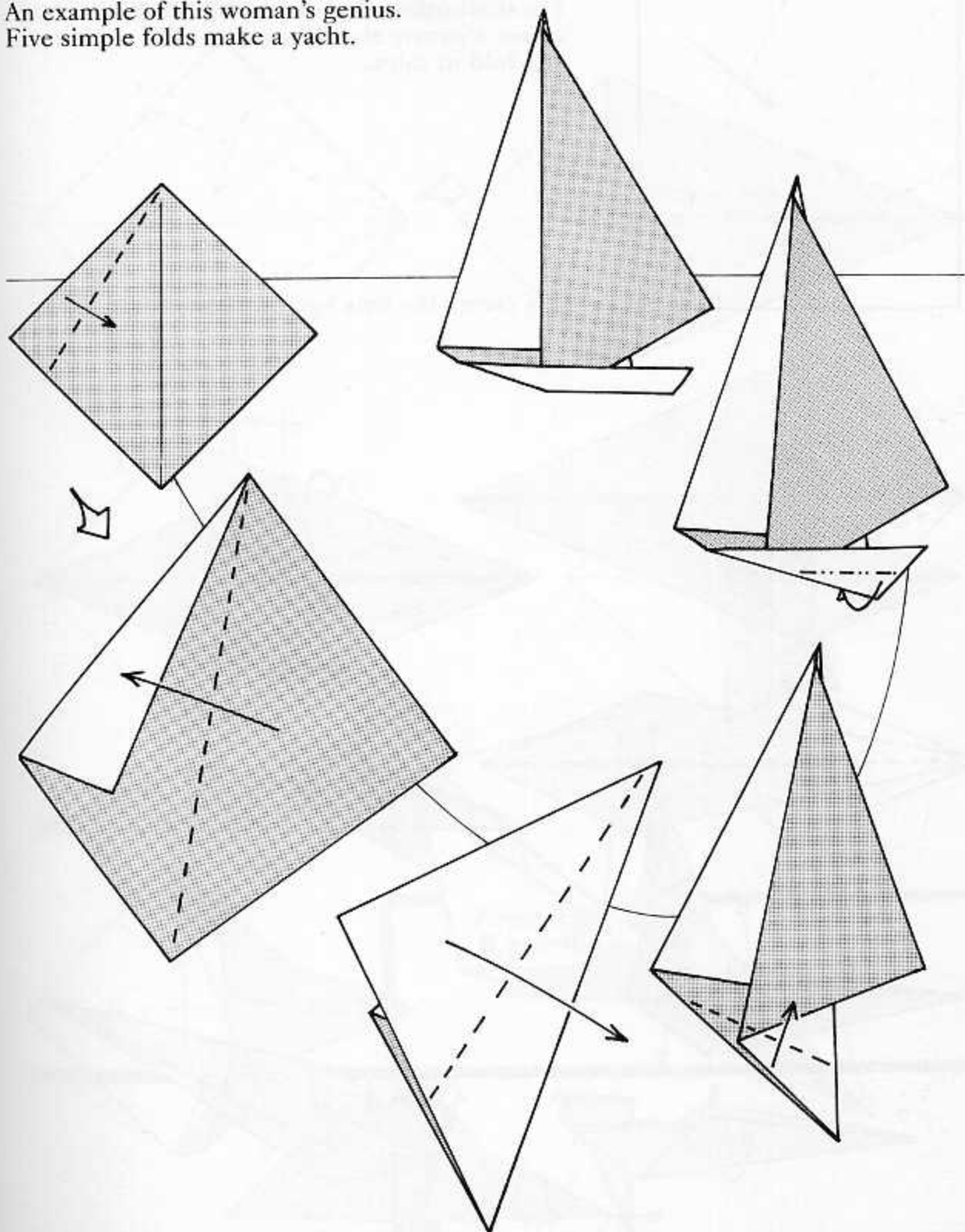

Speedboat Ian Archer (age 13) Gt. Britain

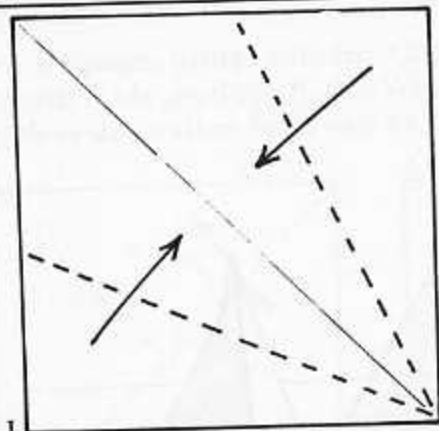

For this outboard motor craft, crease a square along diagonal and fold in sides.

In 5 crease the long narrow flaps

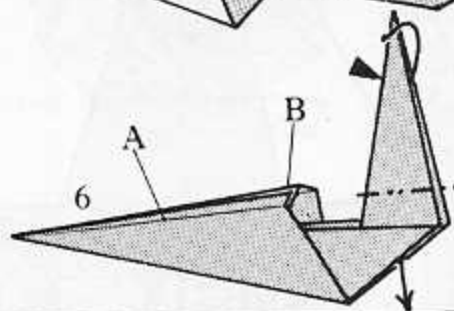
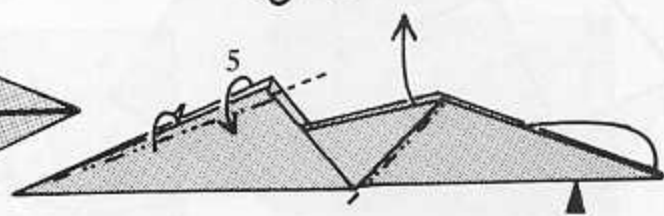
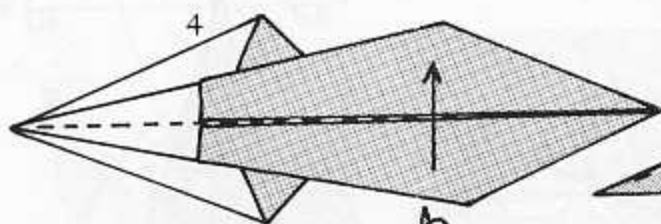
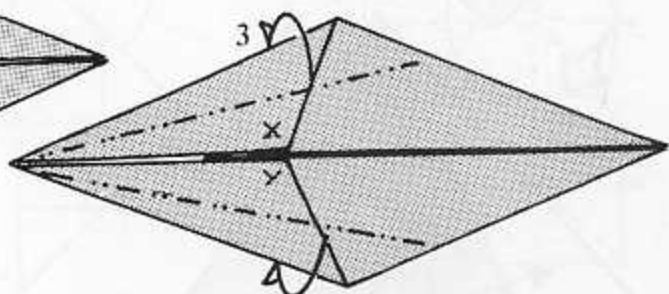
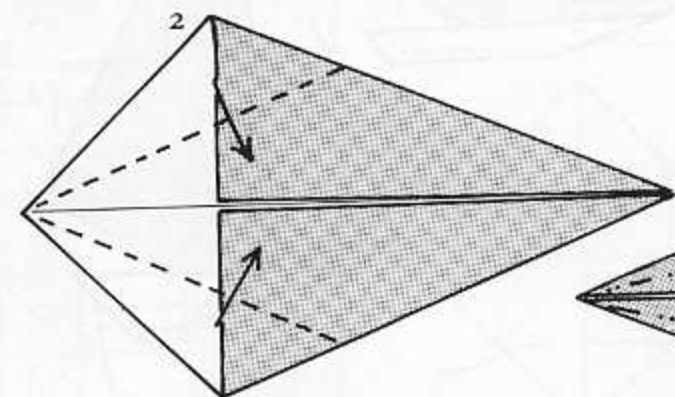

tuck flap A
into flap B

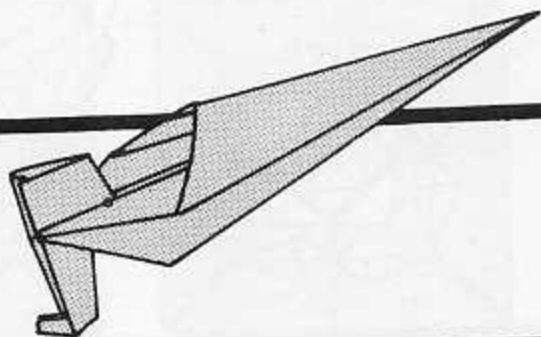
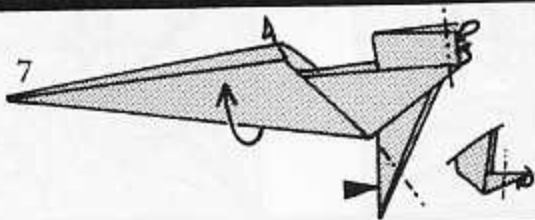

Simple Dart John Smith Gt. Britain

An exercise in folding – mostly valley folds.

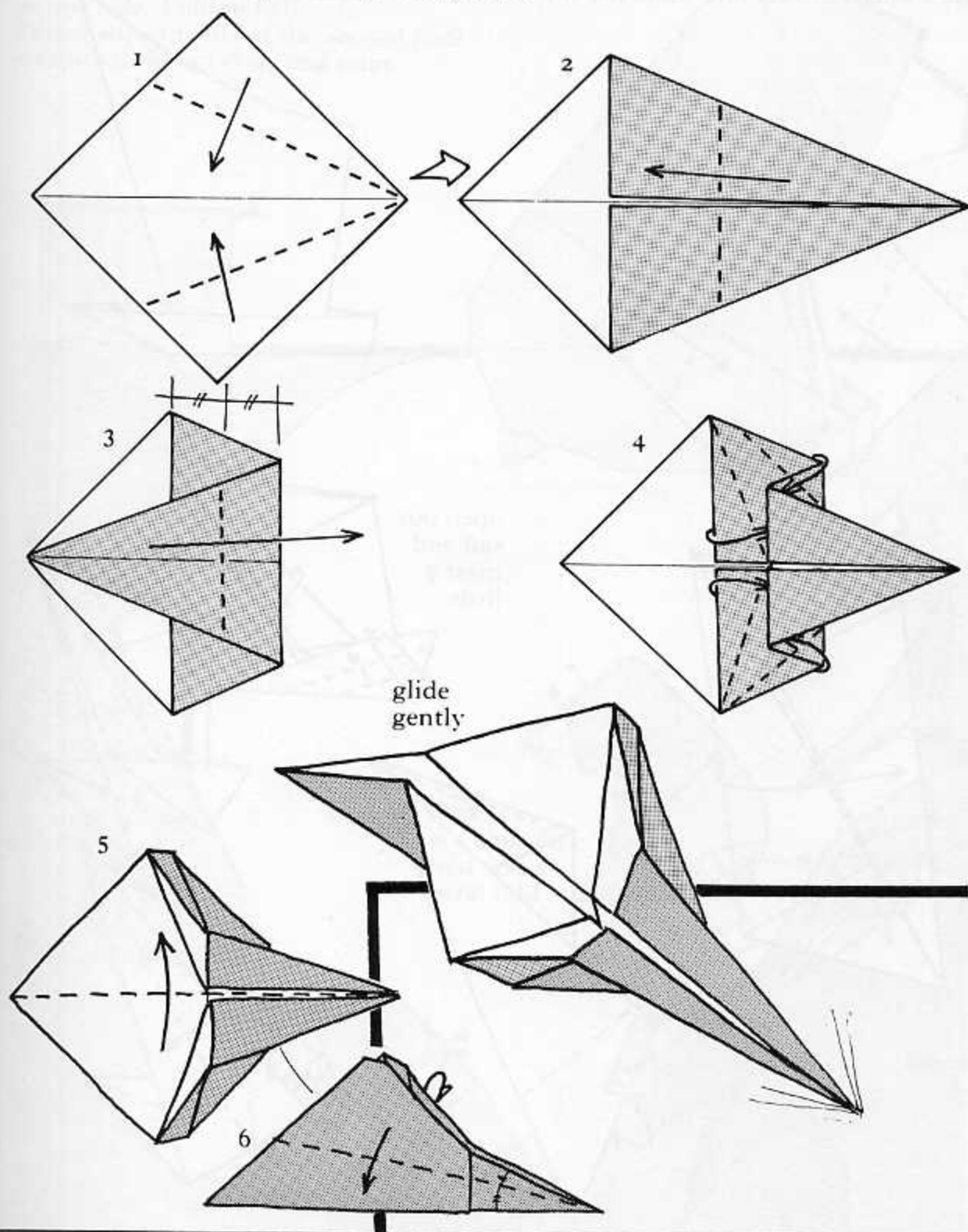

Lakotoi (*New Guinea*) Philip Noble Scotland

Use a square of very thin white paper for this authentic model.

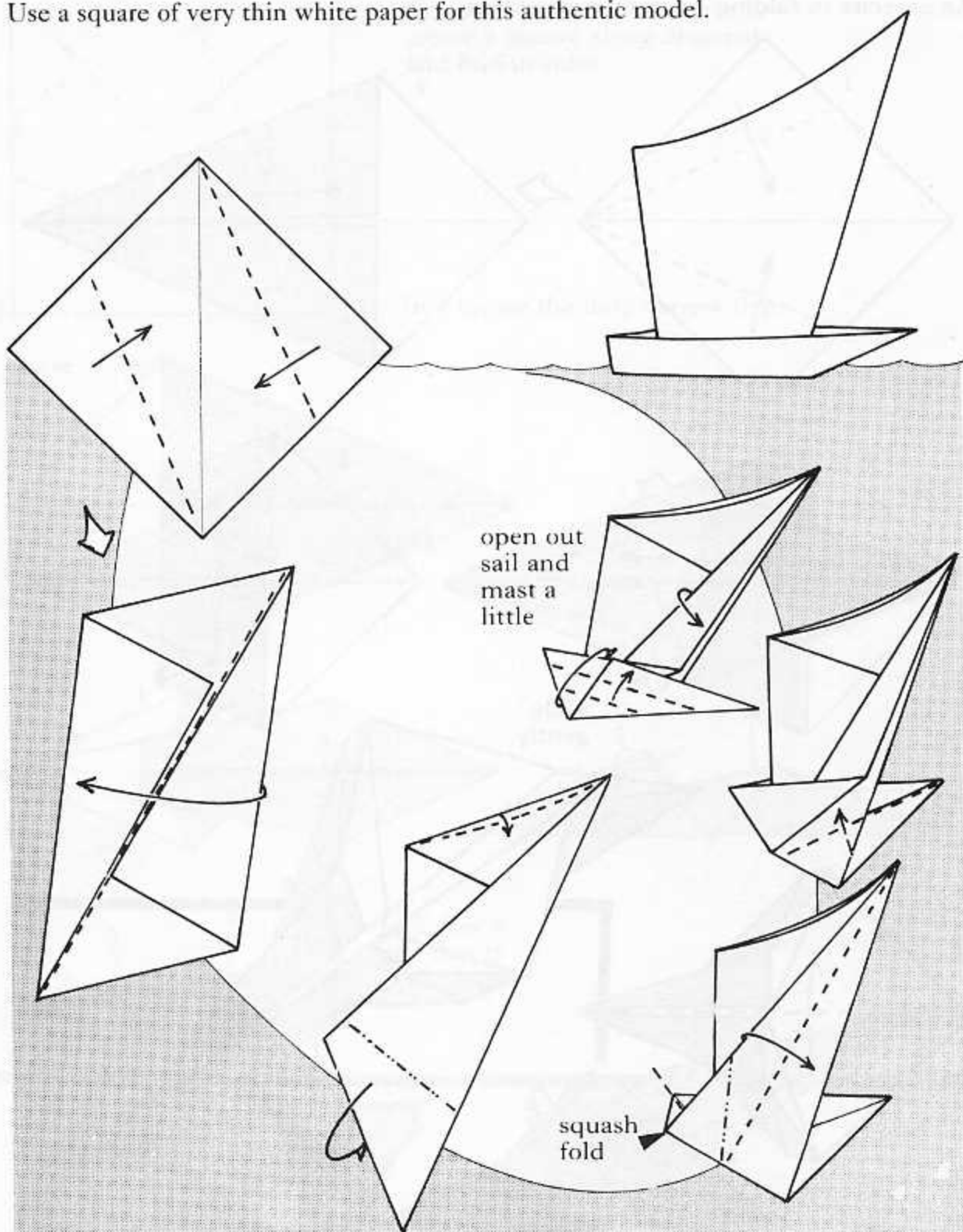

"No Walk Today" Philip Noble Scotland

Use a square of paper, brown on one side. Fold in half.
 Varied adjustments of the second fold
 produce different dogs and pups.

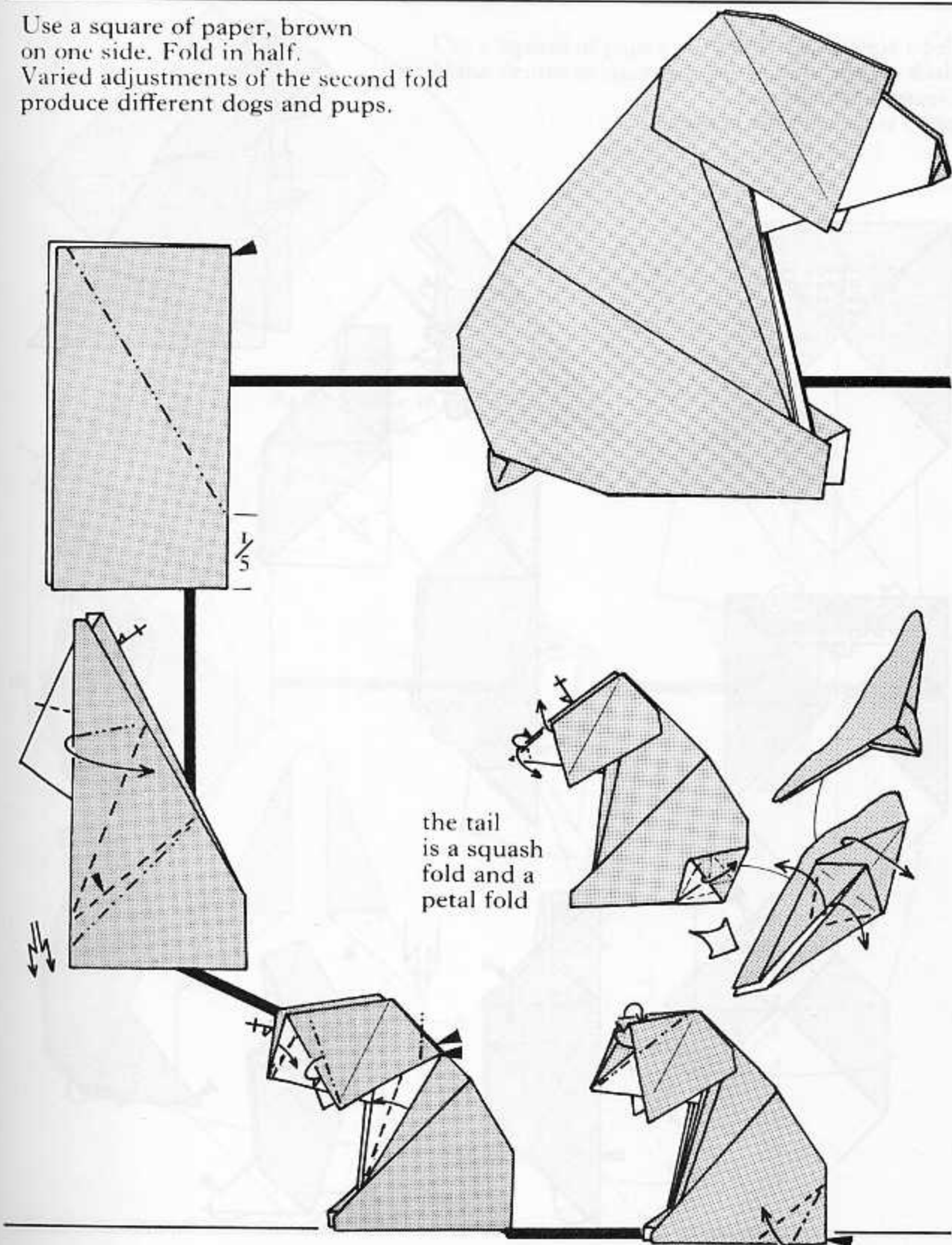

Two Nuns Robert Harbin Gt. Britain

Use a square of paper,
black on one side.
Crease diagonals and
fold 3 corners to the center.

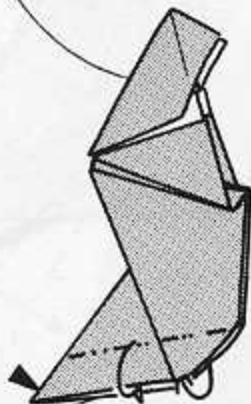
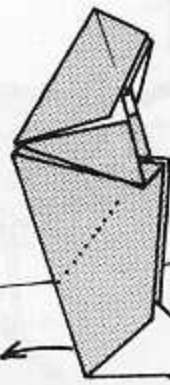
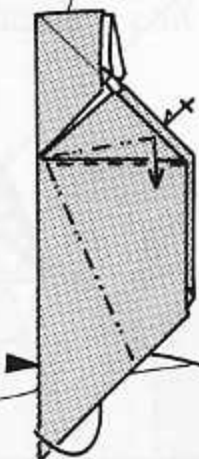
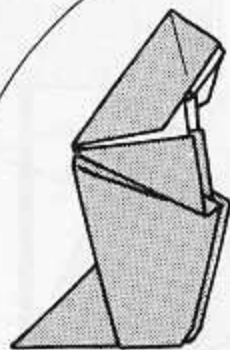
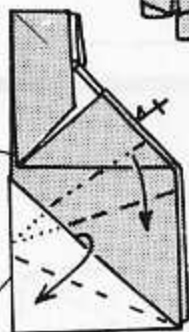
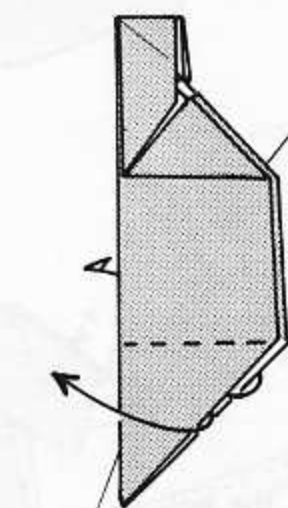
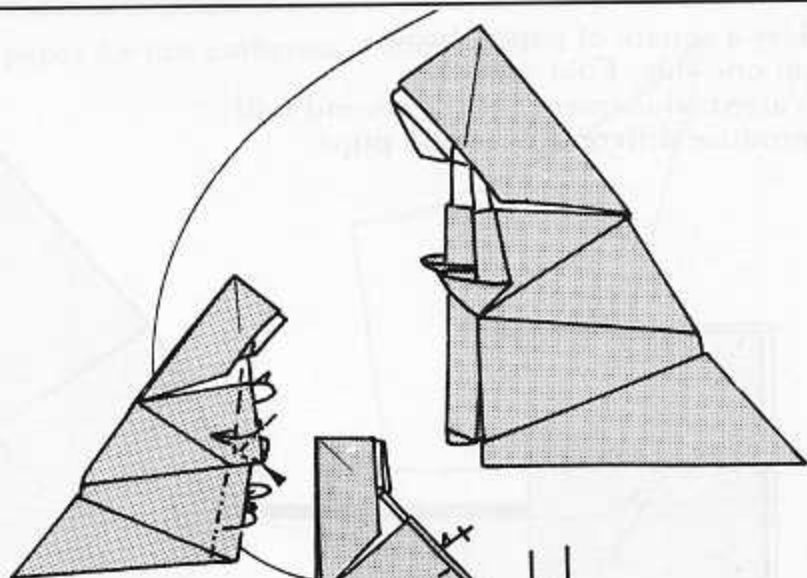
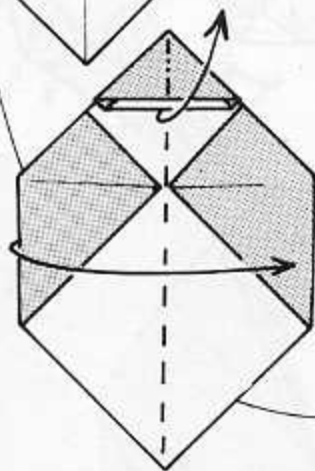
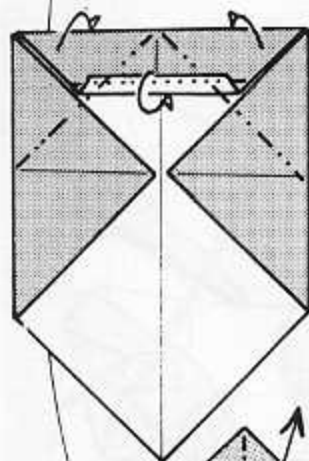
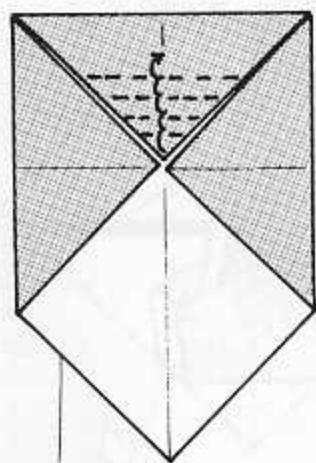

The Film Star Eric Kenneway Gt. Britain

Use a square of paper, yellow on one side.
Make center creases as a guide.

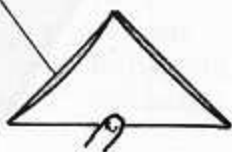
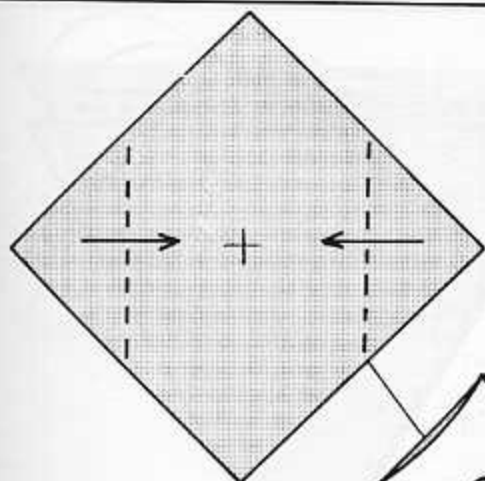

crease in
middle
only

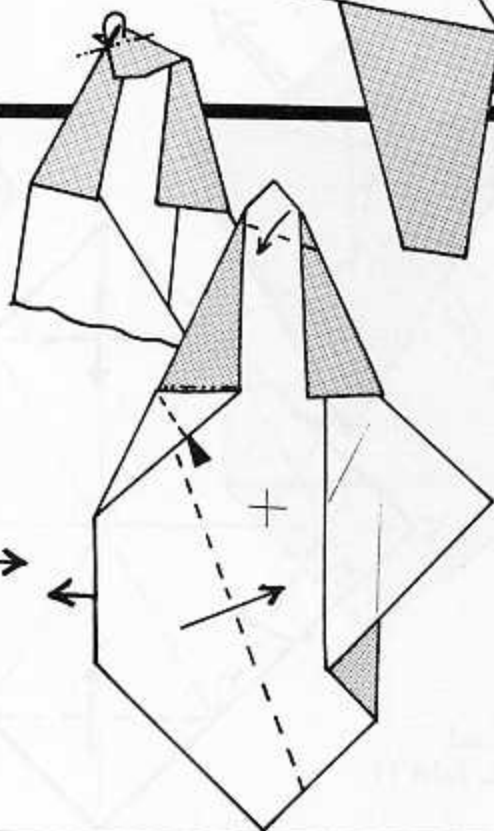
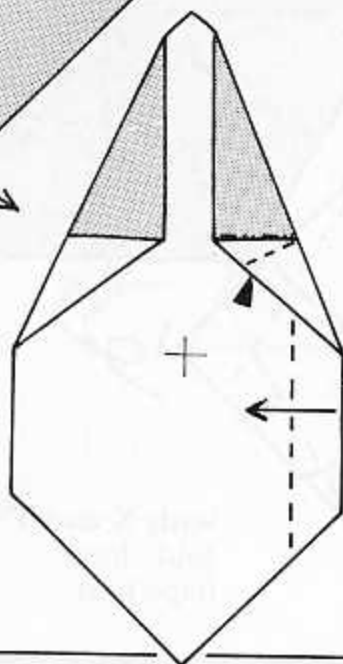
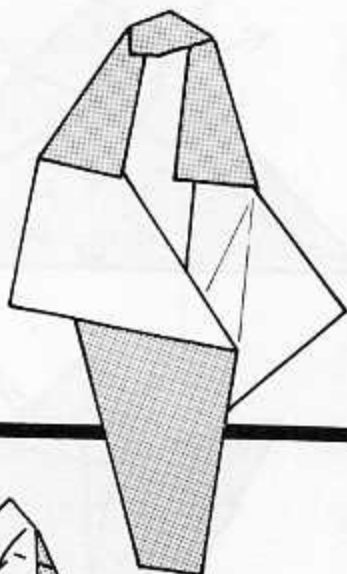
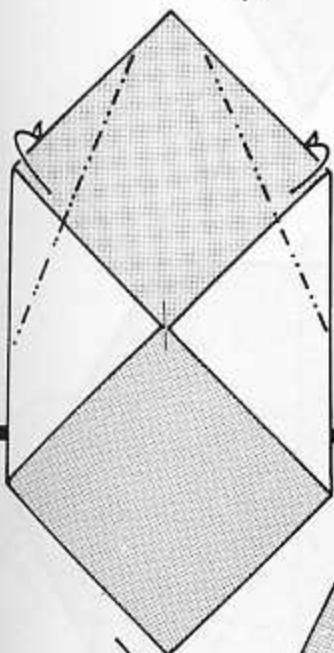

Use a square of paper.
Crease the diagonals,
fold in half, then fold
points right then left.

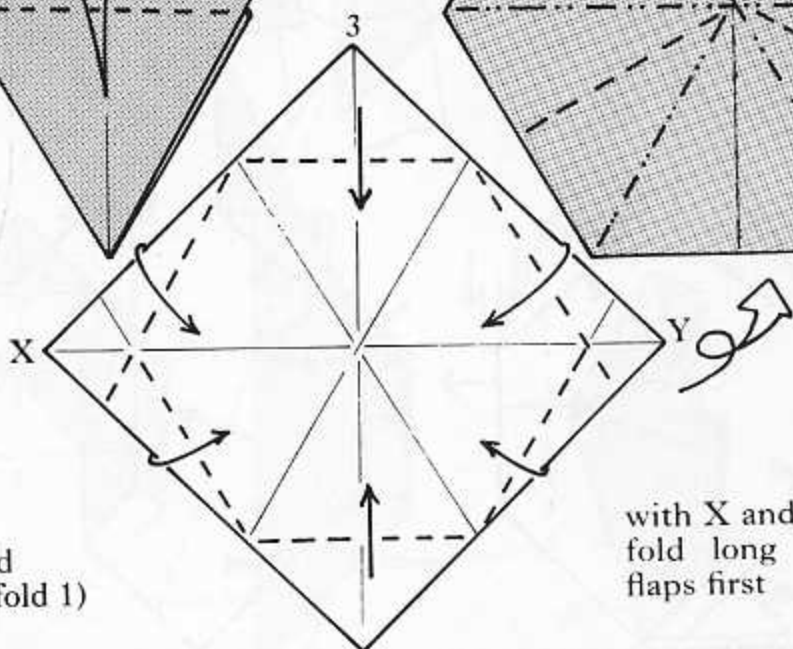
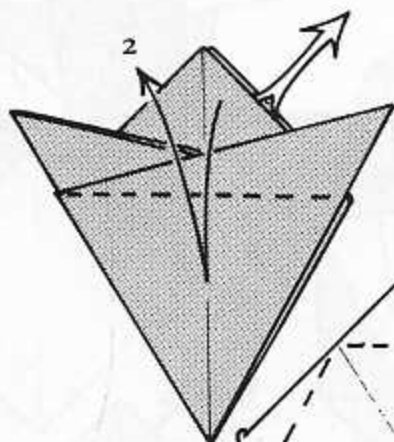
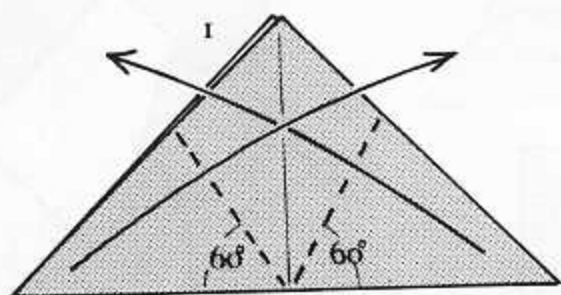

completed fold
(see page 32, fold 1)

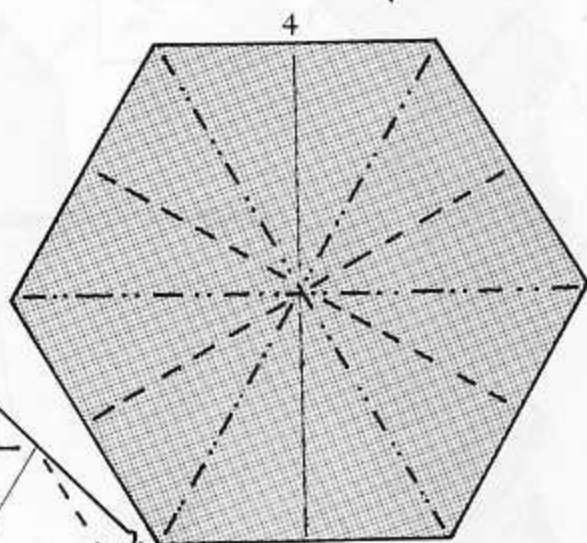
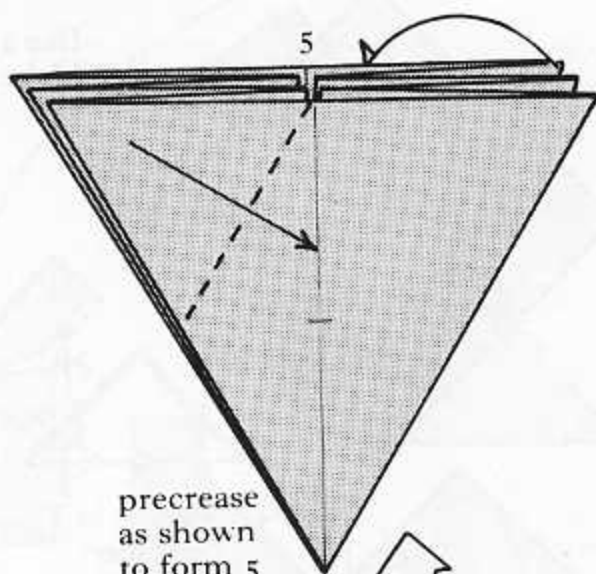

with X and Y
fold long
flaps first

Octahedron (continued)

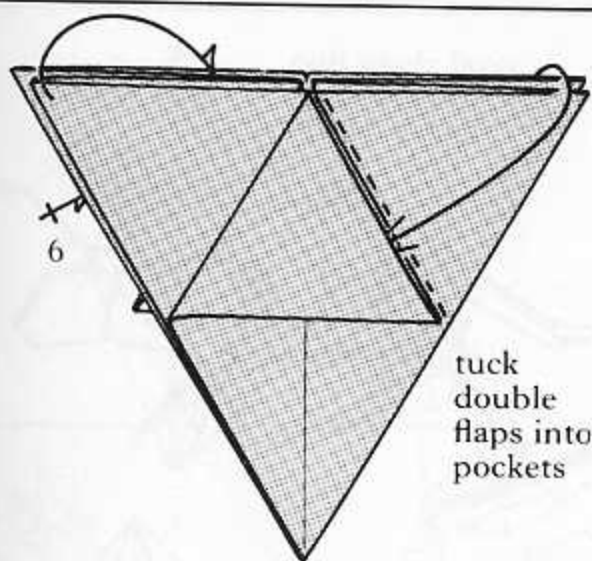

tuck
double
flaps into
pockets

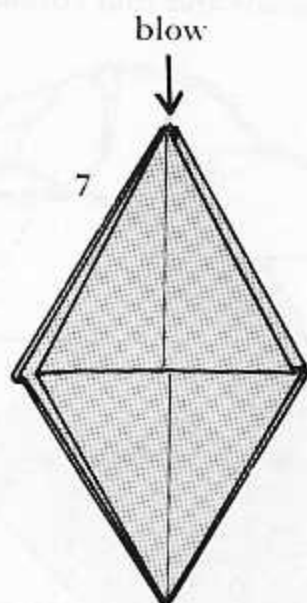

air coming
out

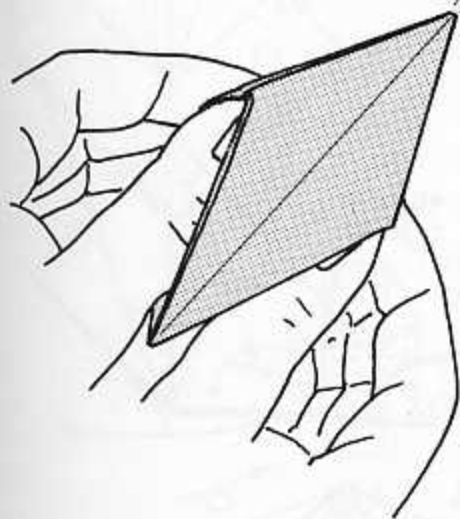

put thumbs
into pockets
to make bellows

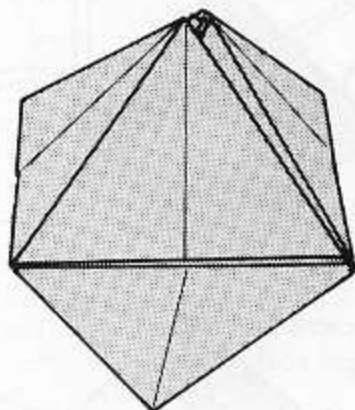

Stalking Cat Patricia Crawford U.S.A.

Use a square of foil white side down.
Crease diagonals and fold corners as indicated.

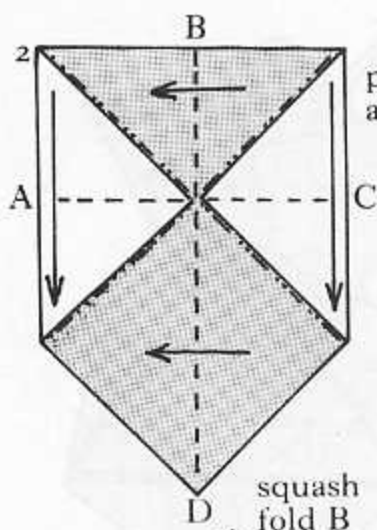
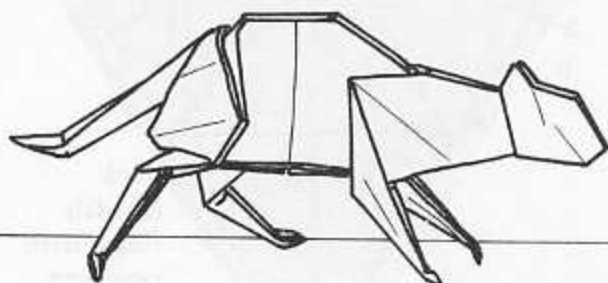
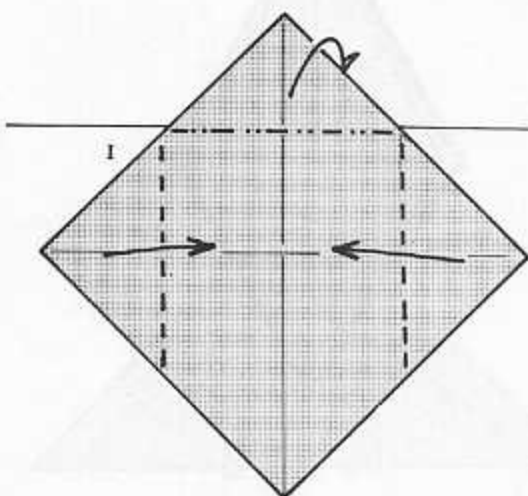

precrease
and fold

squash
fold B

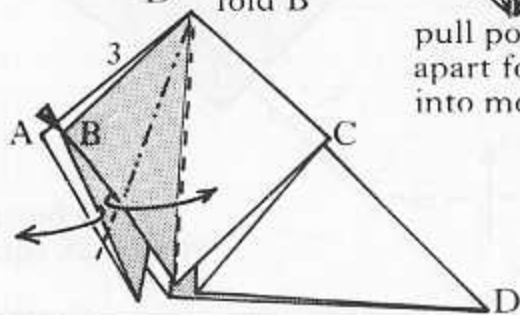

pull points
apart fold B
into model

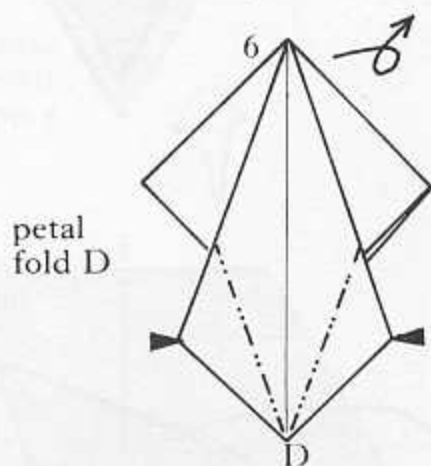
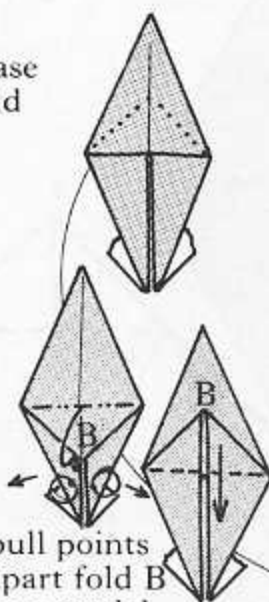

petal
fold D

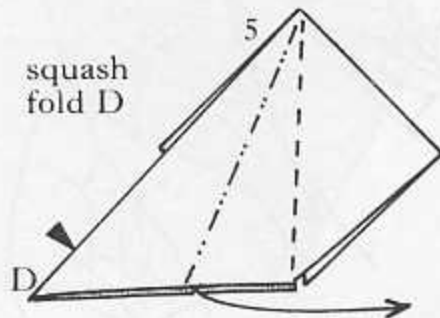

squash
fold D

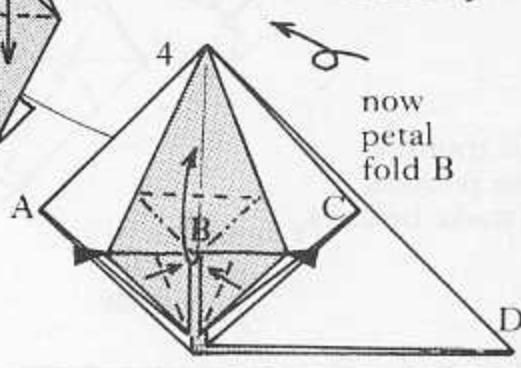

now
petal
fold B

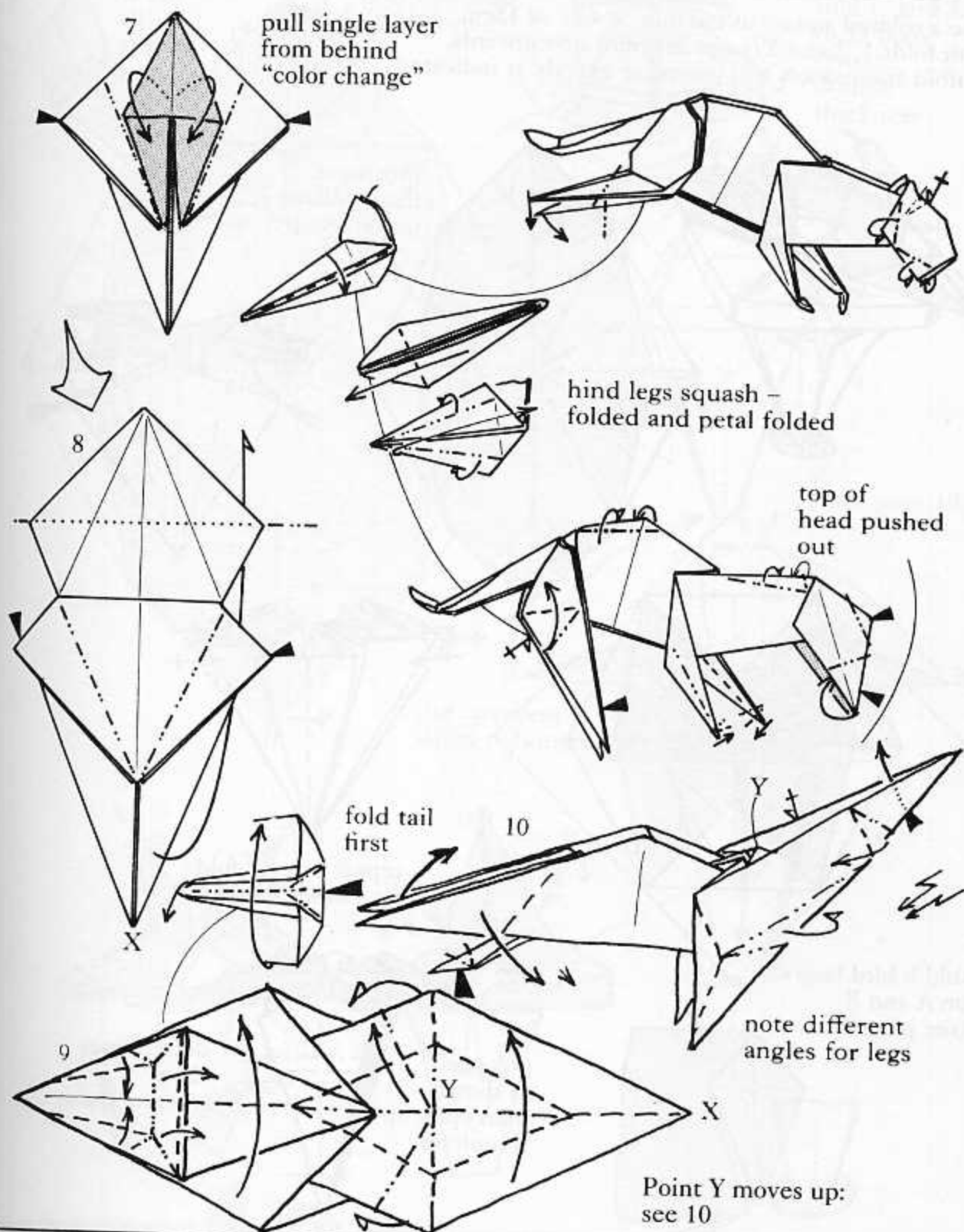

Birdbath Patricia Crawford U.S.A.

Use a colored square of foil (6in. × 6in. or 15cm. × 15cm.). Begin with folds 1, 2 and 3 (page 28) color side inwards. Unfold two corners and precrease exactly as indicated.

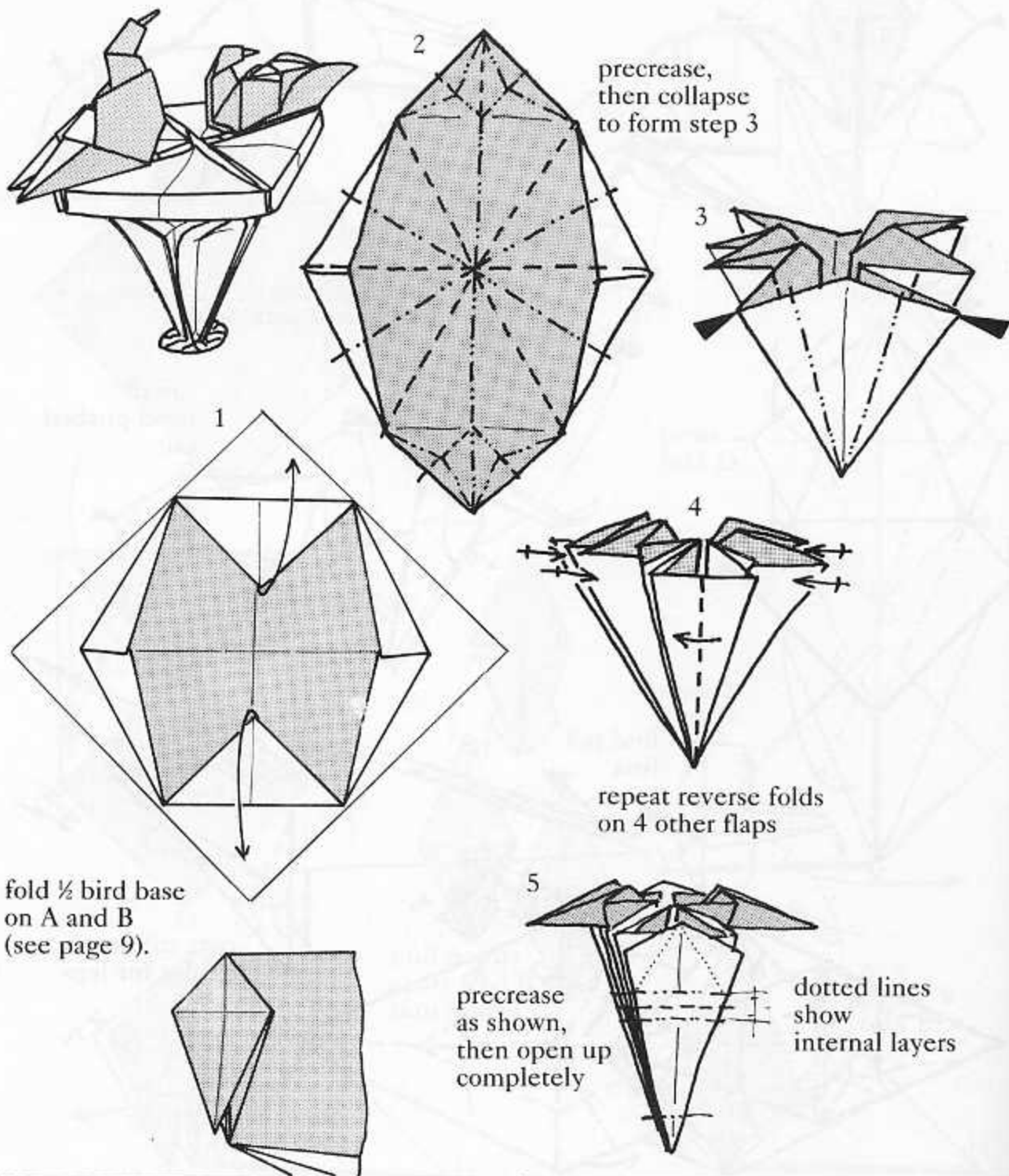

Birdbath (continued)

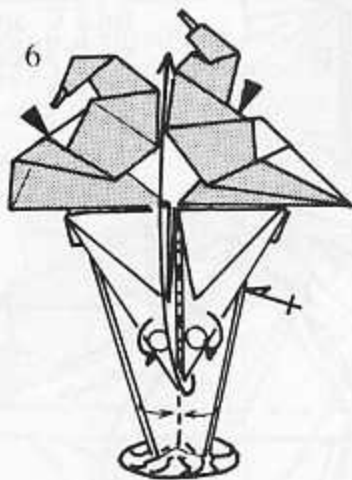

6
mountain fold
points front and
rear and lift up;
bring leg flaps
together;
press birds down

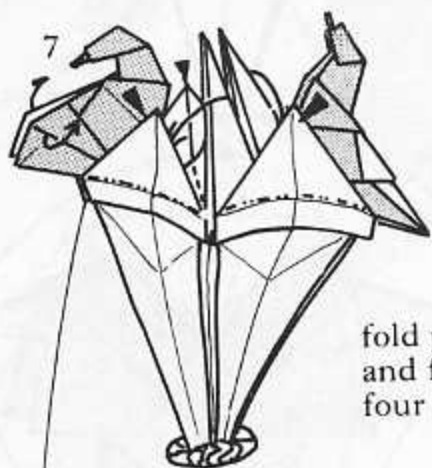
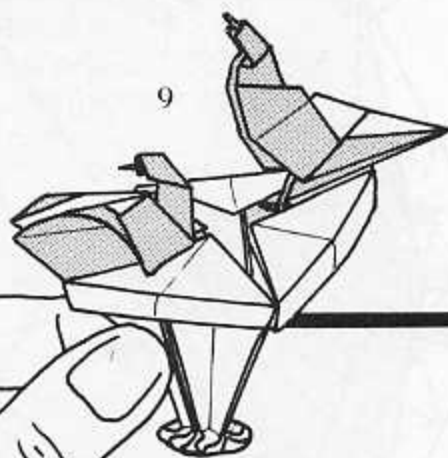

7
fold points in
and fold in
four triangles

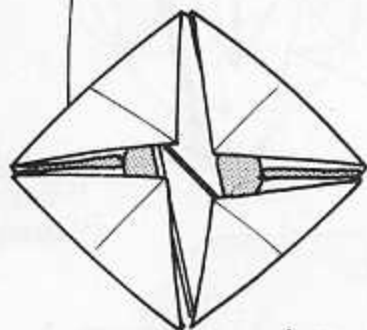

8
top view
without birds

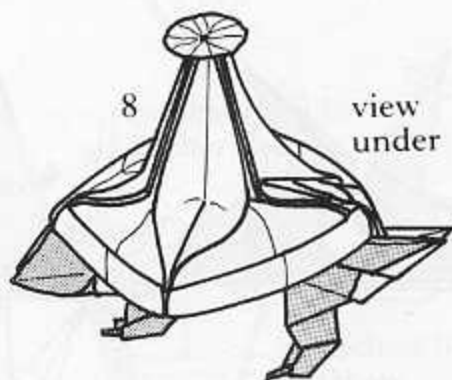

8
view
under

Squirrel on a Log Patricia Crawford U.S.A.

Use a square of foil, gold
or log-like on one side

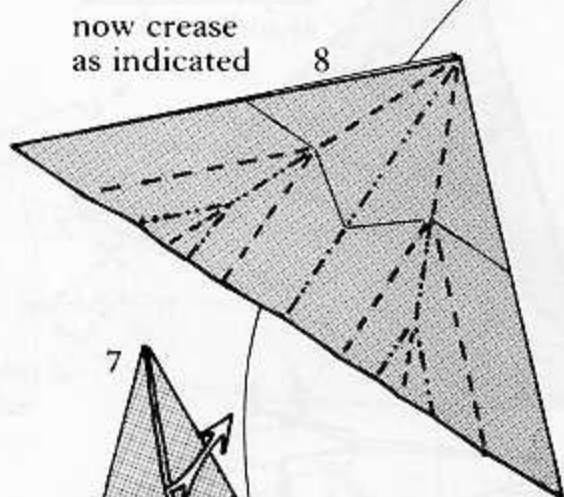
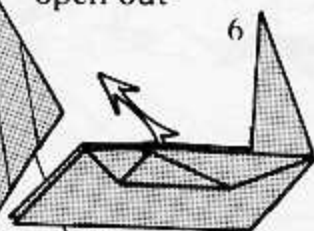
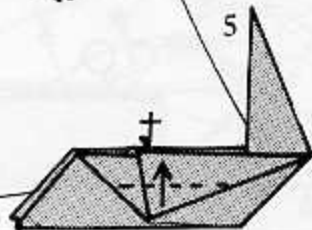
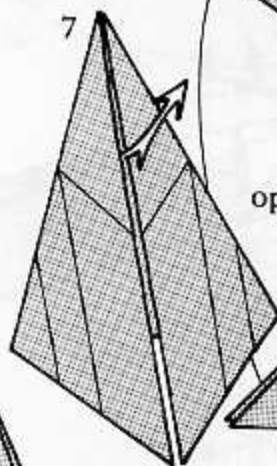
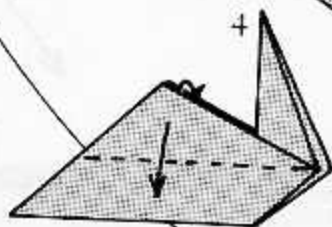
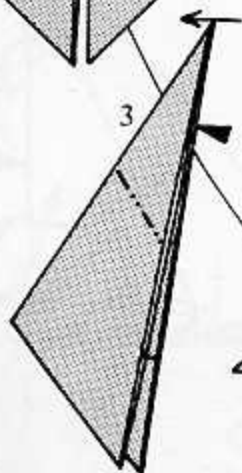
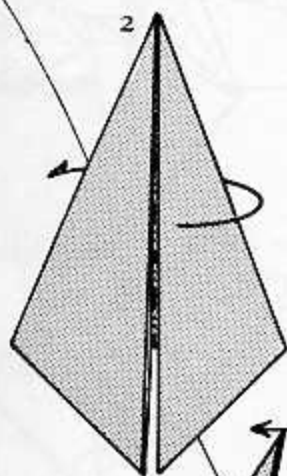
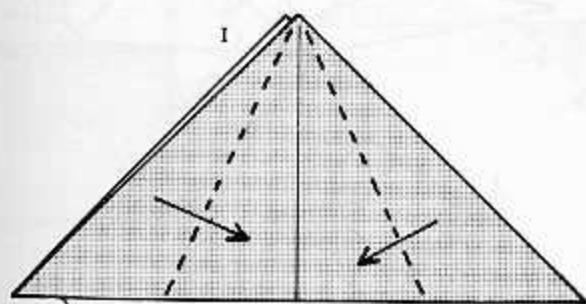
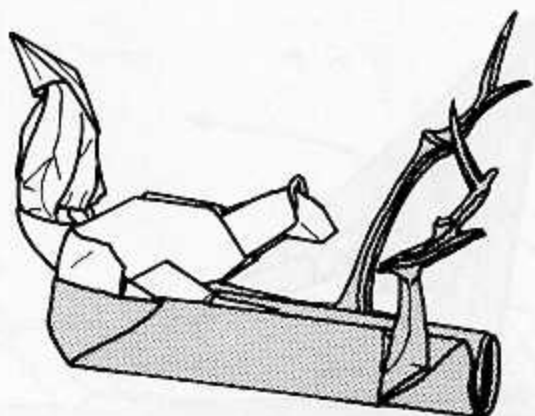

precreasing
folds

open out

now crease
as indicated

Squirrel on a Log (continued)

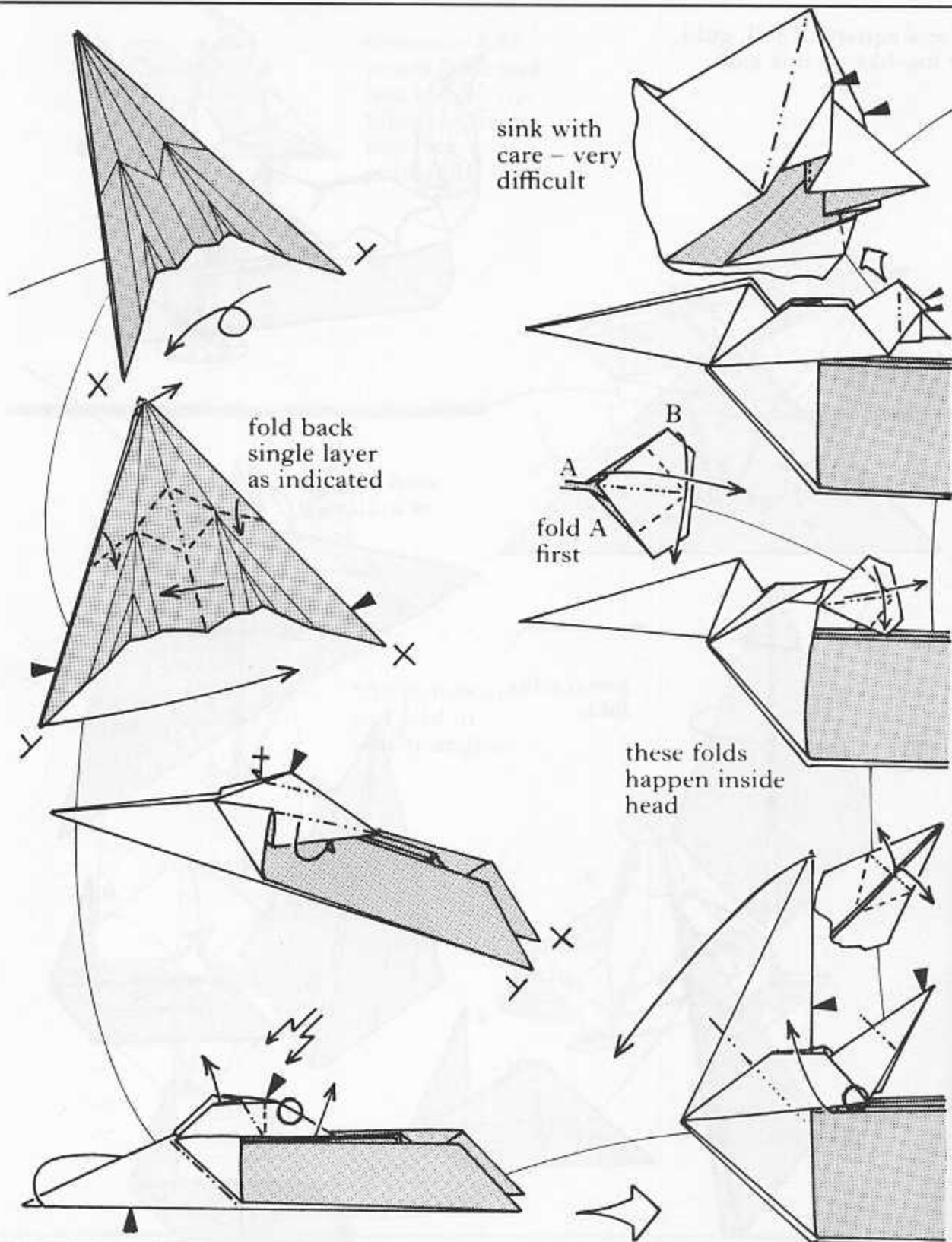

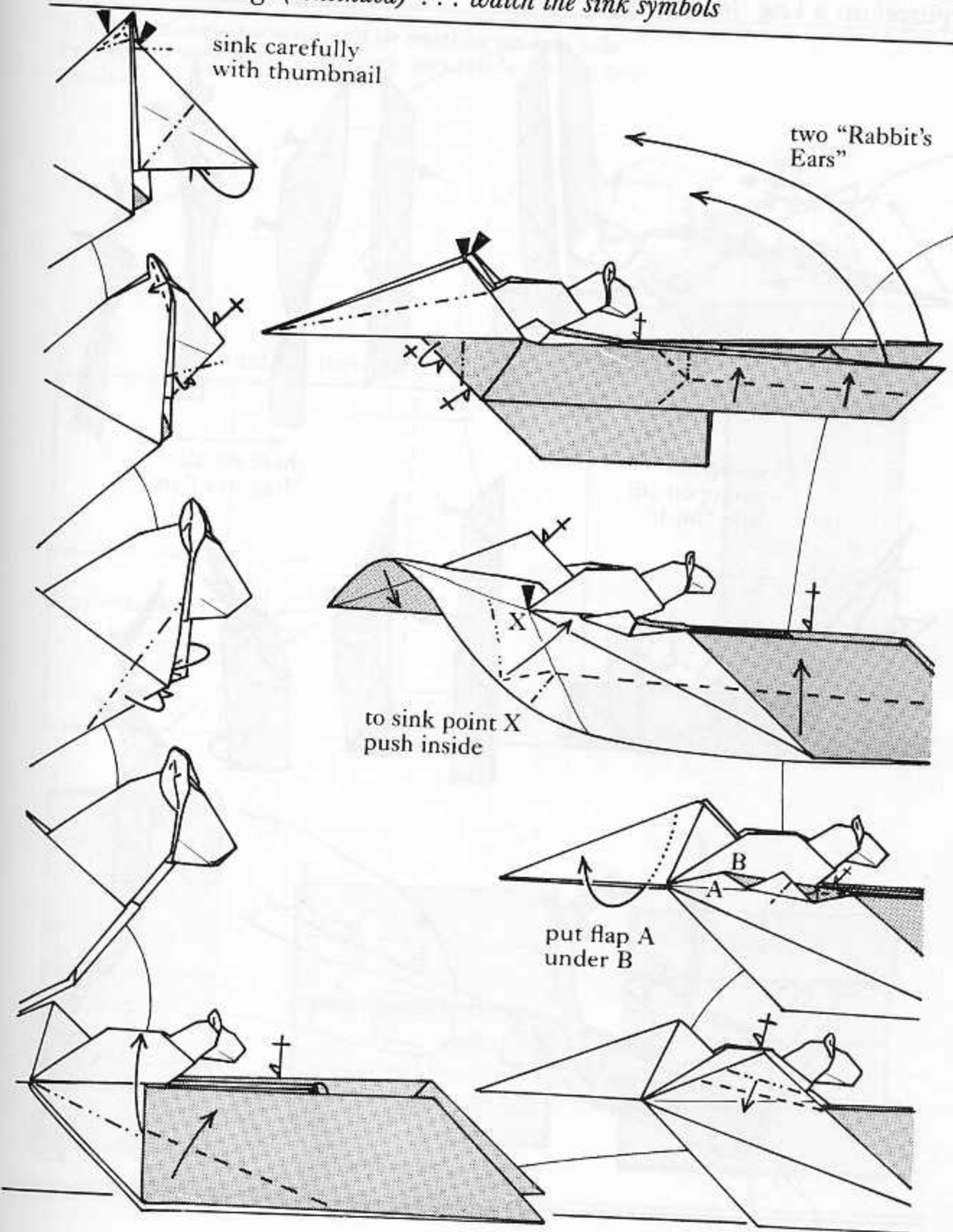

Squirrel on a Log (continued)

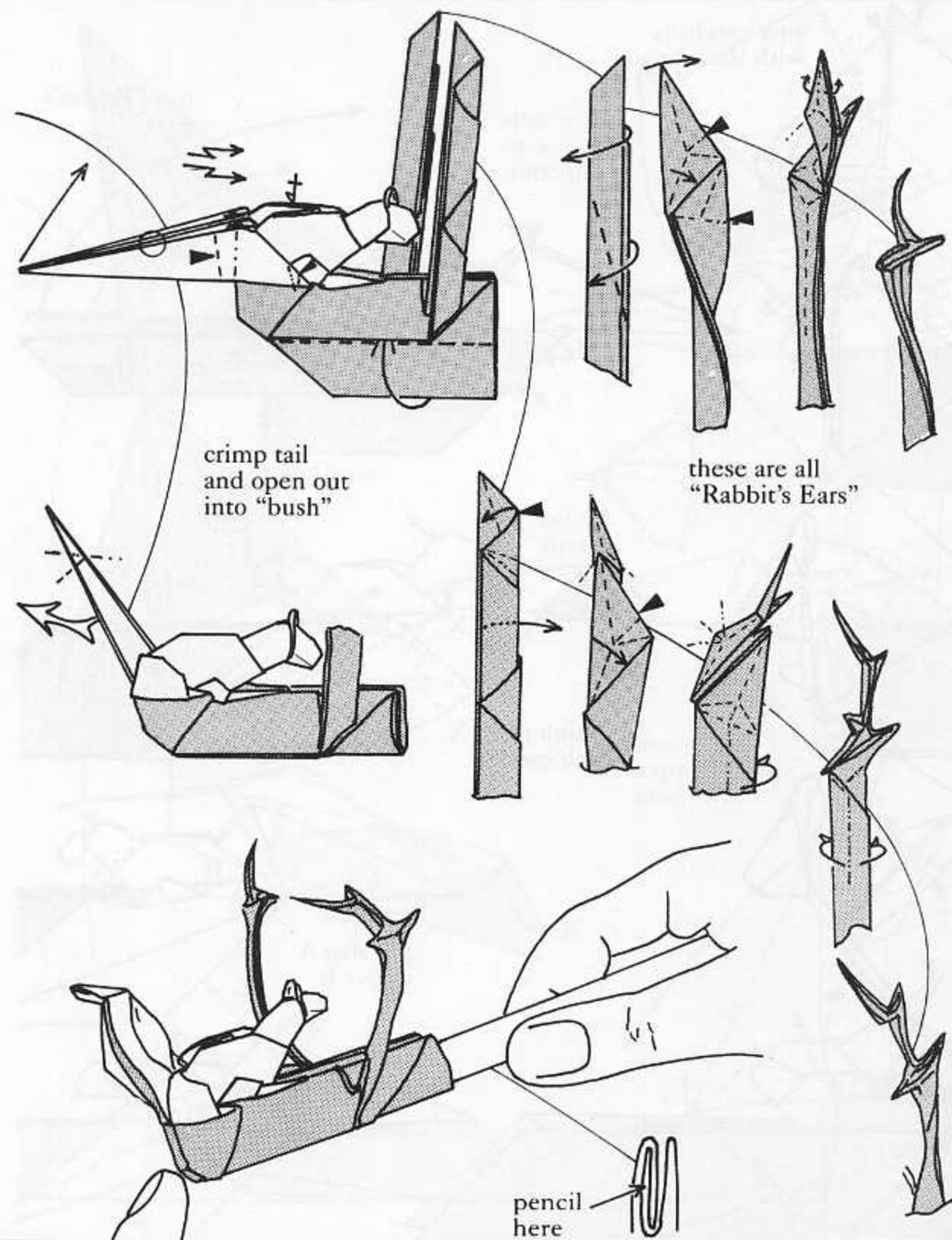

2 × 3 rectangle brown, gold or nestlike on one side.
Foil works well here. Fold very accurately for the best results.

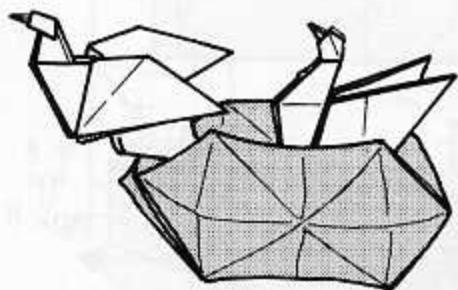

1 fold left then right

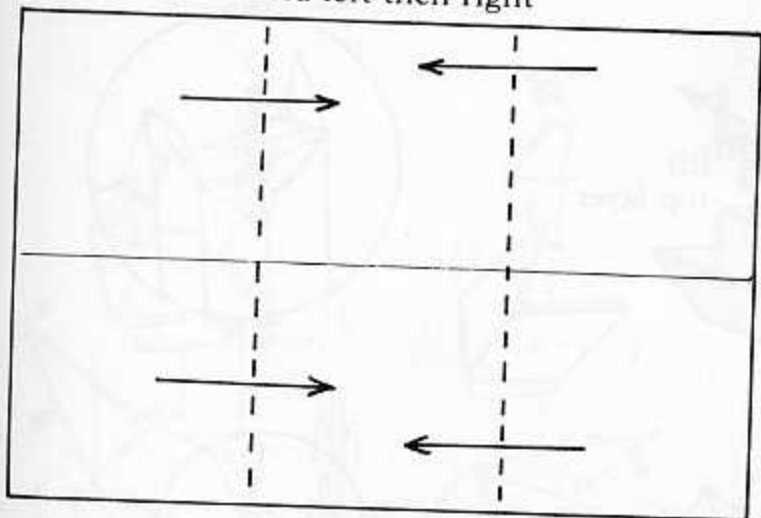

2

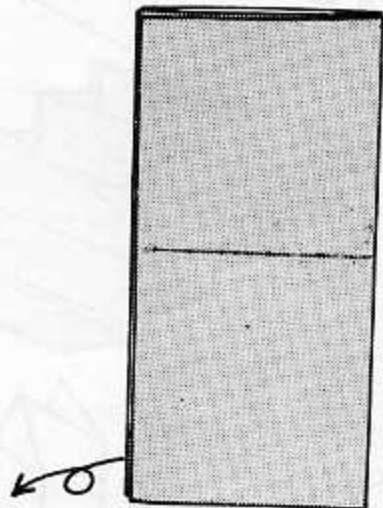

3

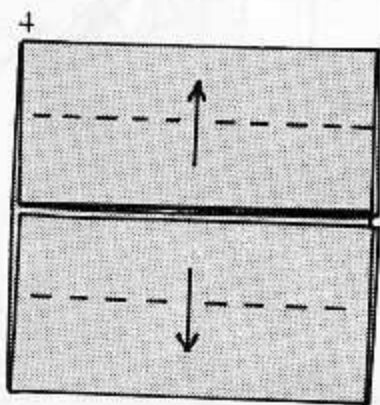
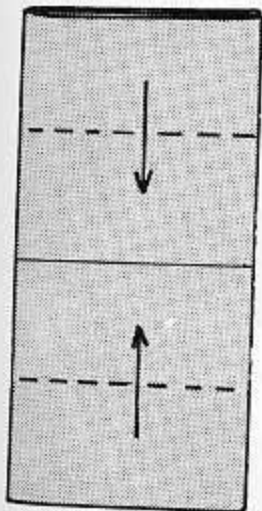

5

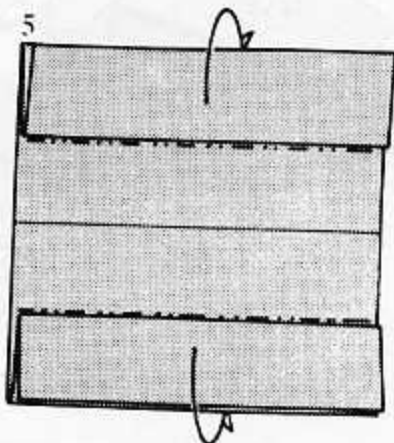

Birds in a Nest (continued) . . . firm creases, please

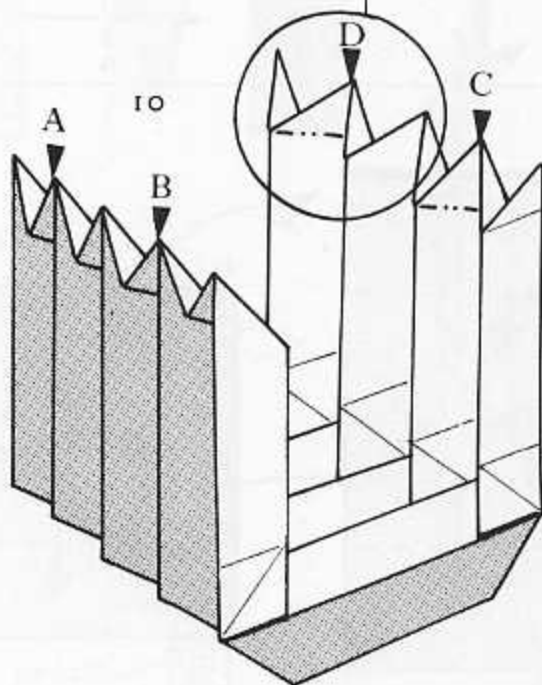
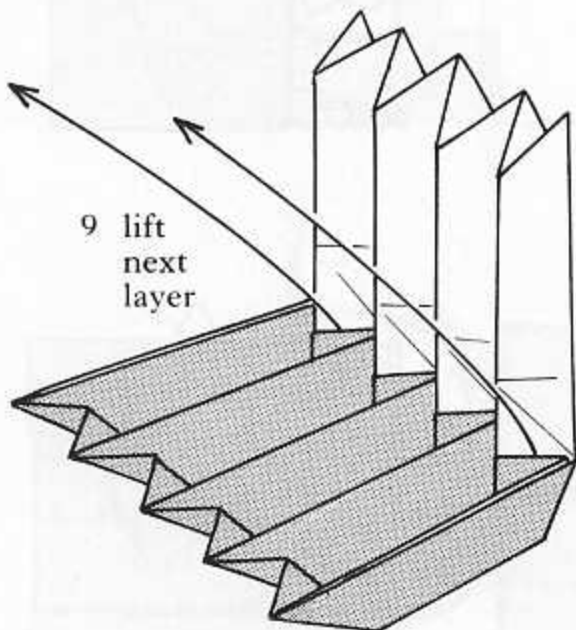
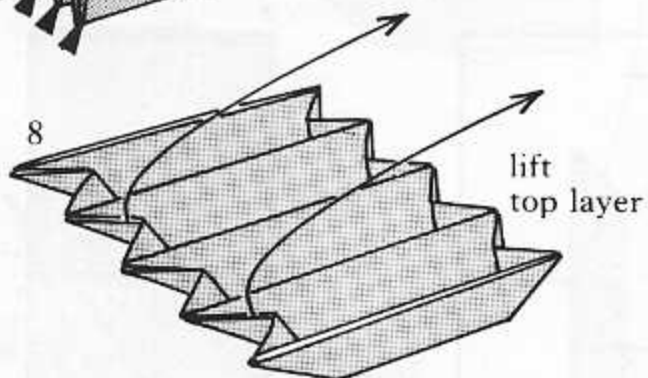
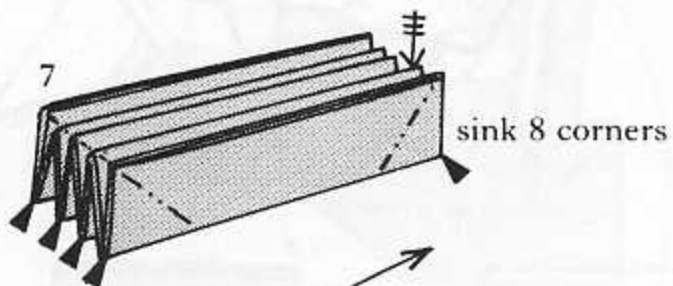
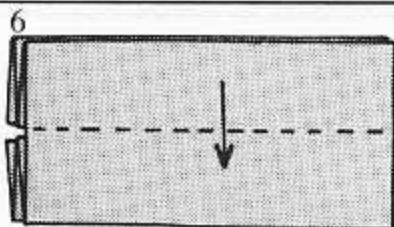

repeat
folds with
A, B and C

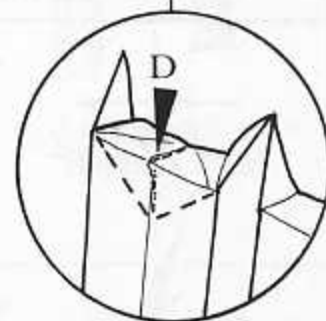

Birds in a Nest (continued)

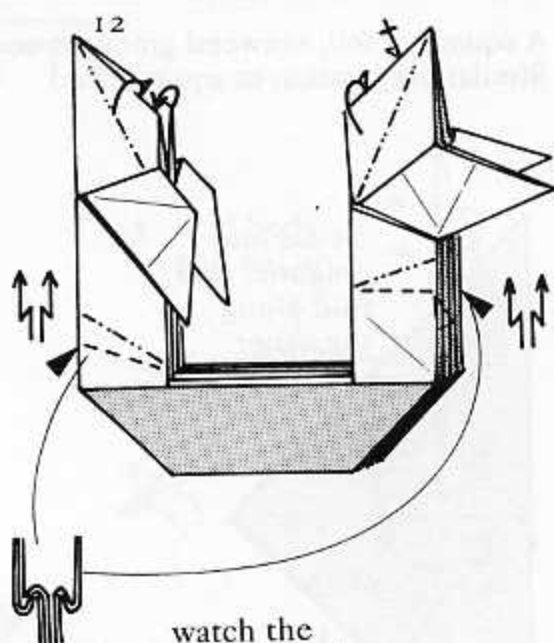
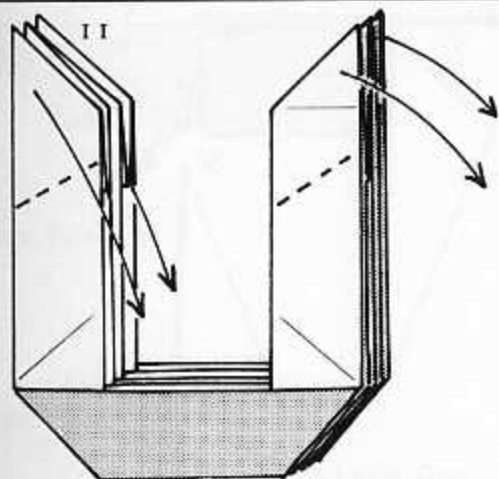

watch the
crimps used
4 times

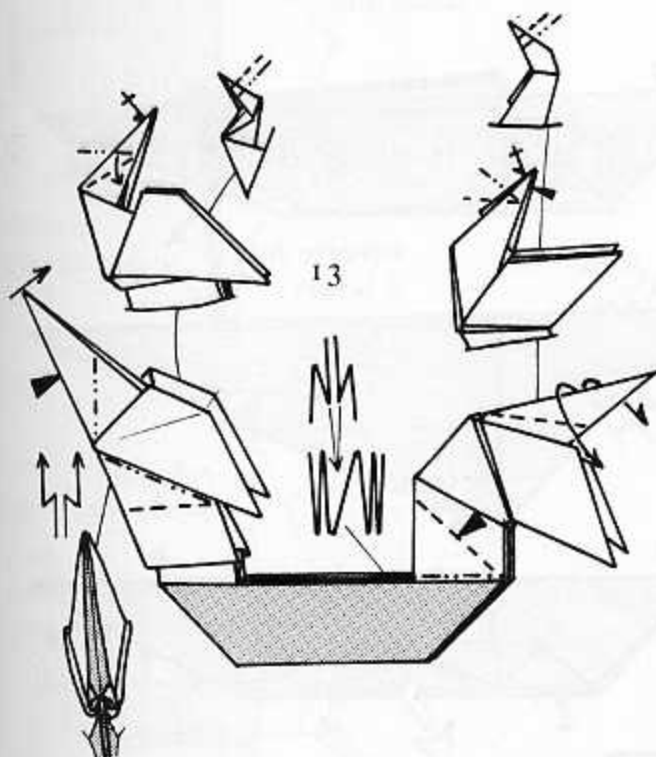

the crimp
enters
body fold

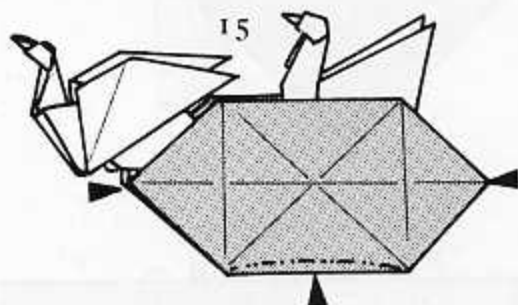

press nest
into shape

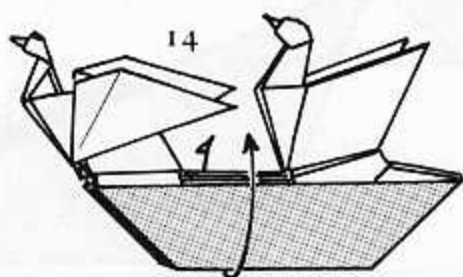

Mermaid Patricia Crawford U.S.A.

A square of foil, seaweed green on one side.
Similar preparation to squirrel fold.

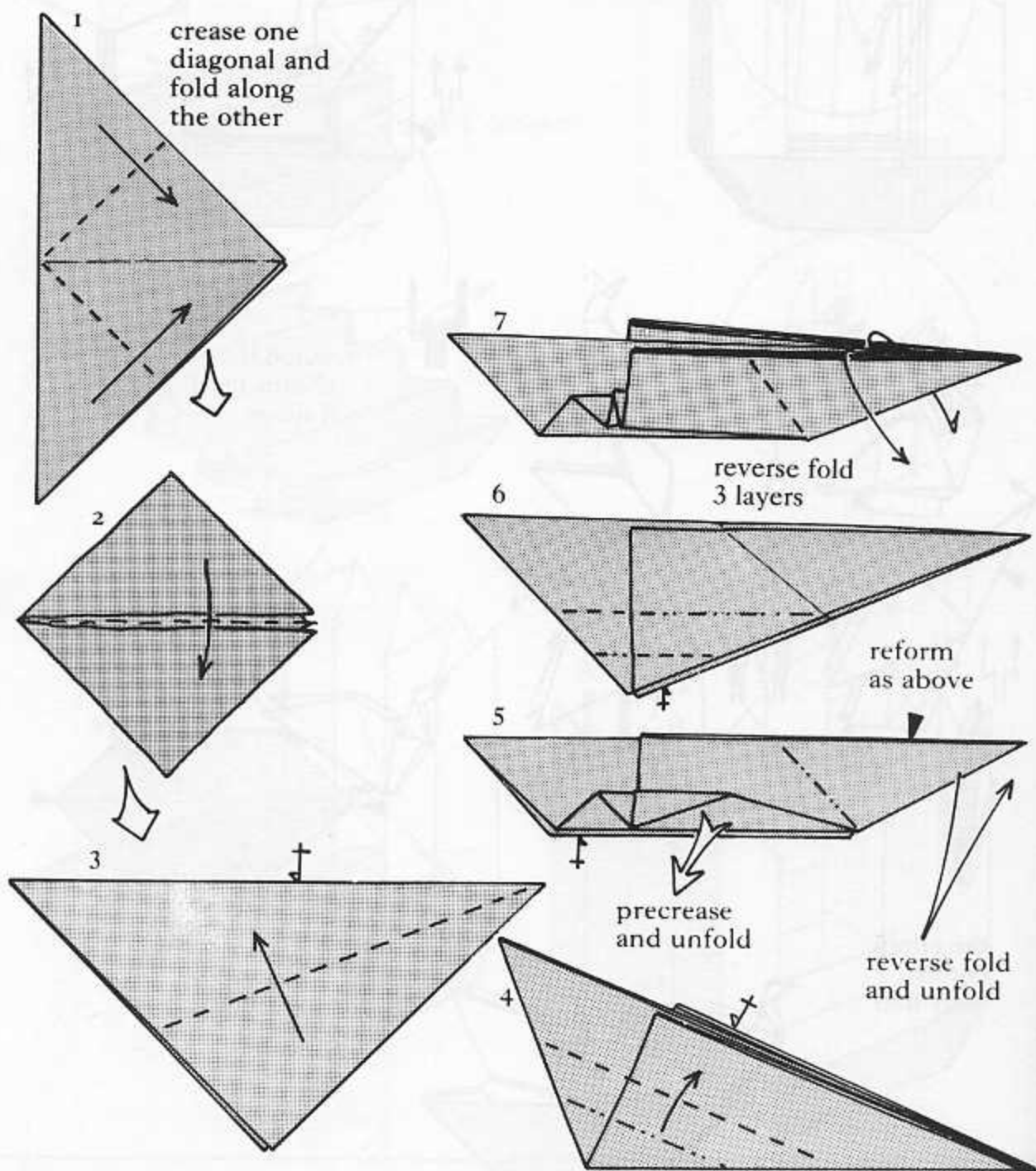

Mermaid (continued) . . . very difficult folds ahead

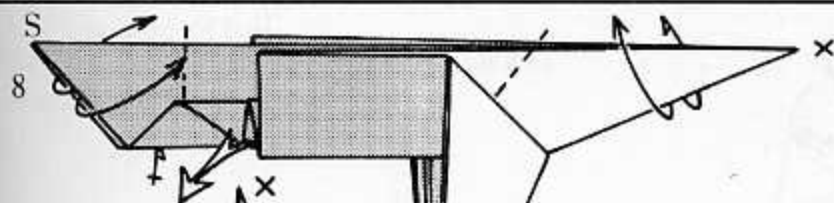

S (see fold 14)

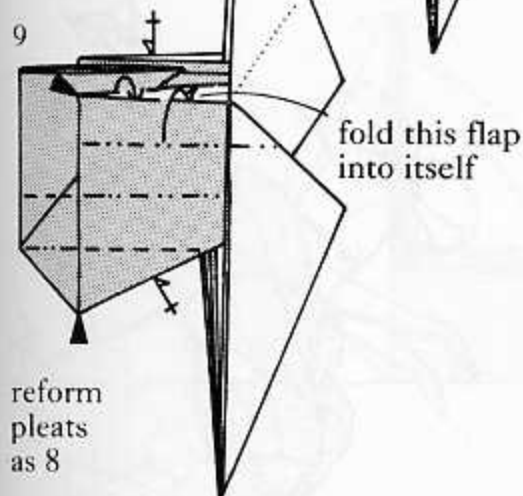
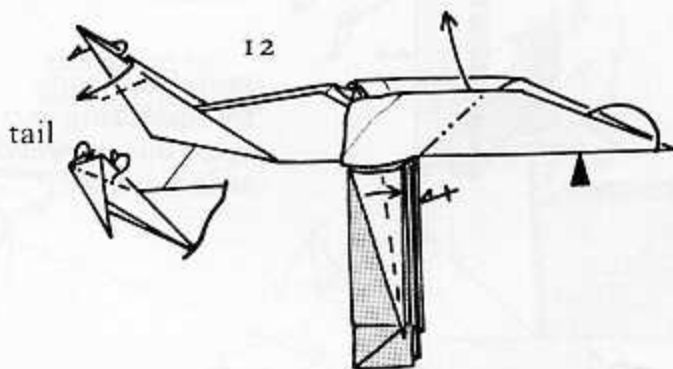
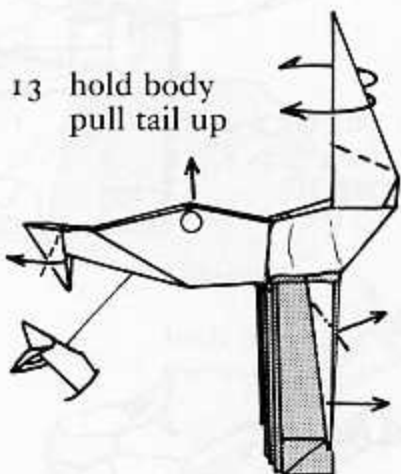
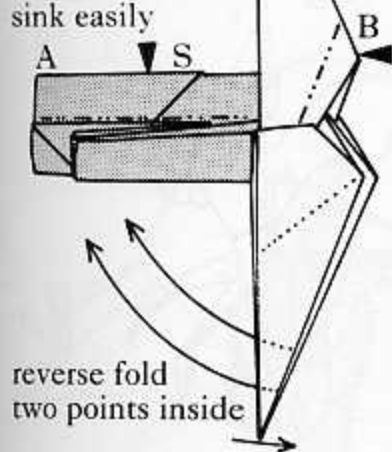
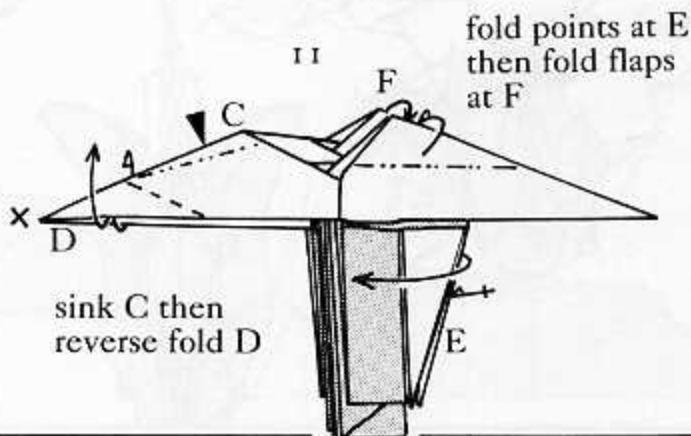
reform
pleats
as 810
sink A
and B will
sink easilyreverse fold
two points
insidesink C then
reverse fold Dfold points at E
then fold flaps
at F

Mermaid (continued)

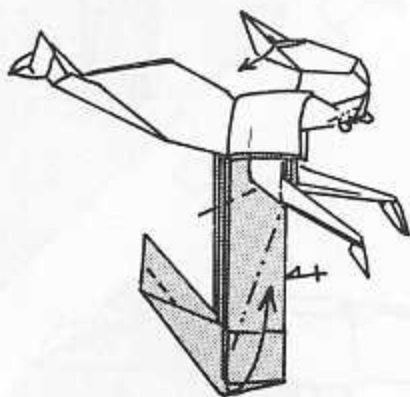
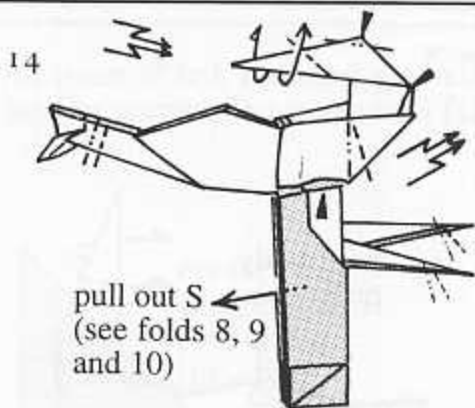

round the body
by squeezing and
open out seaweed
as indicated

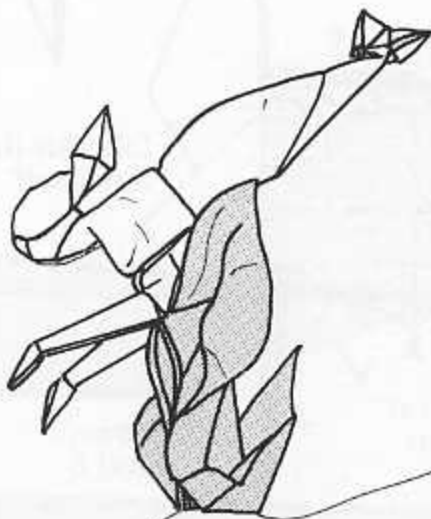
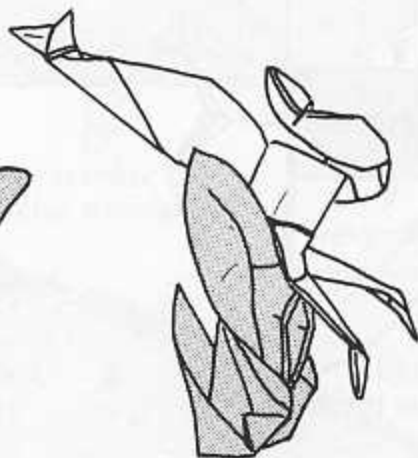
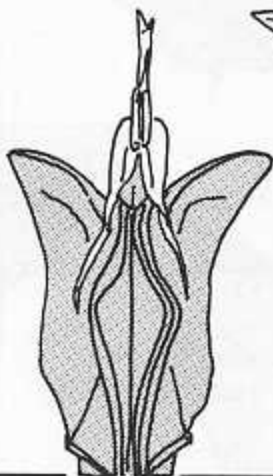
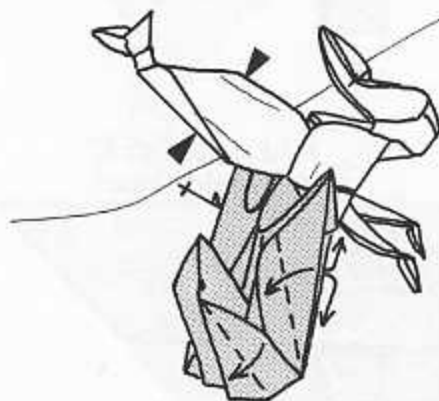

Christ on the Mount of Olives Patricia Crawford U.S.A.

Use a square of foil.
 Begin fold 8 of the Mermaid (page 43).
 Note slight alteration in 1.

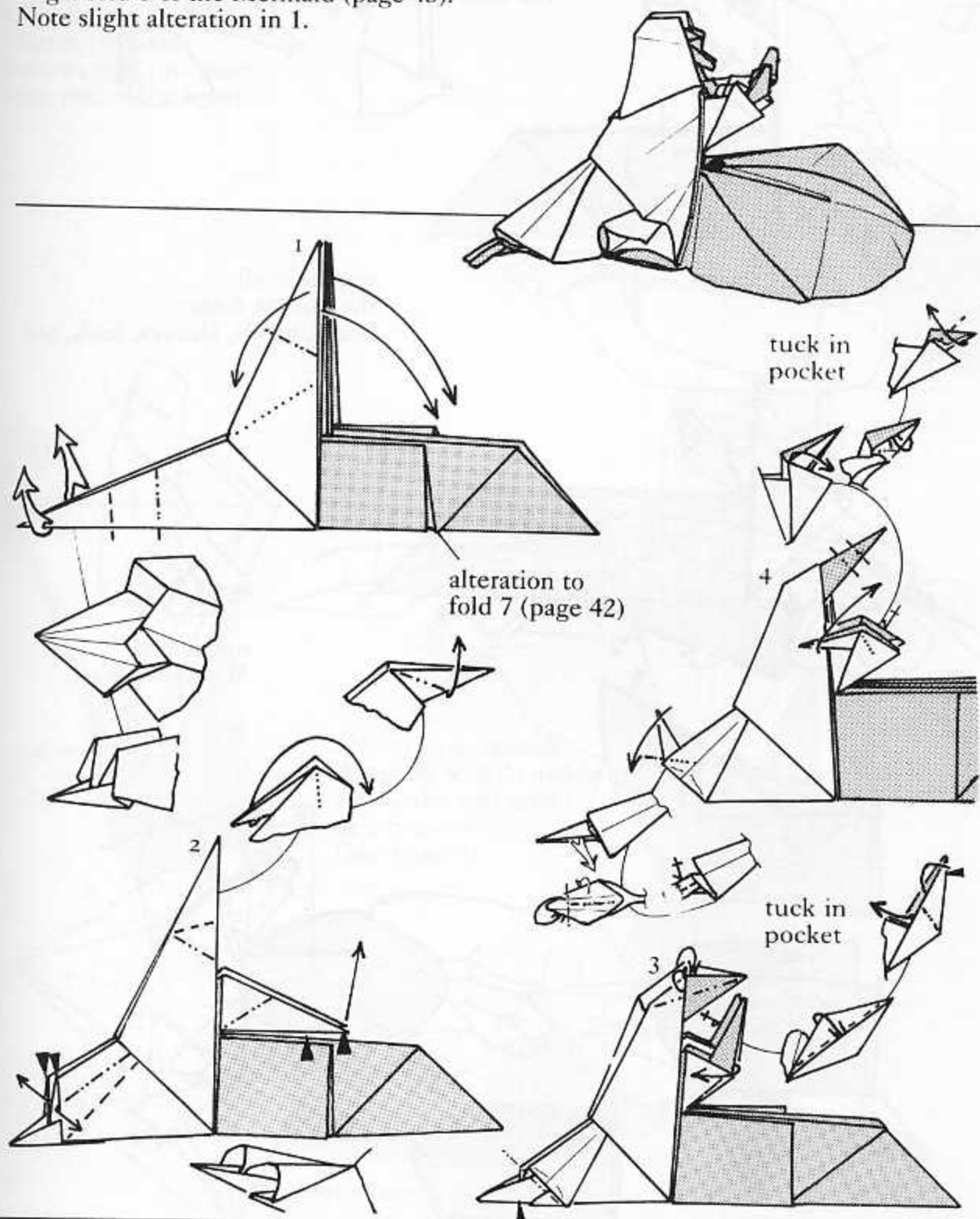

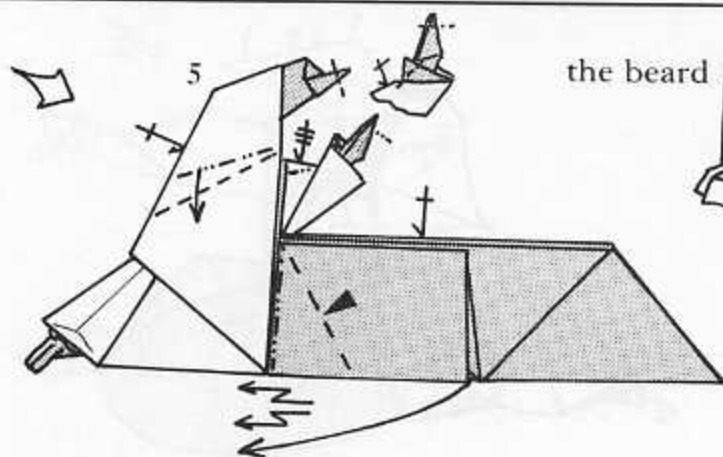
Christ on the Mount of Olives *(continued)*

the beard

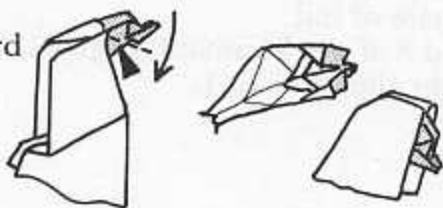

watch for all
the minute folds:
beard, hands, sleeves, back, etc.

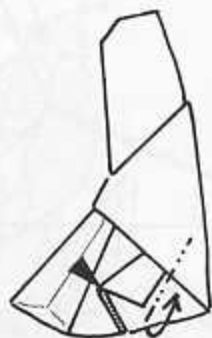
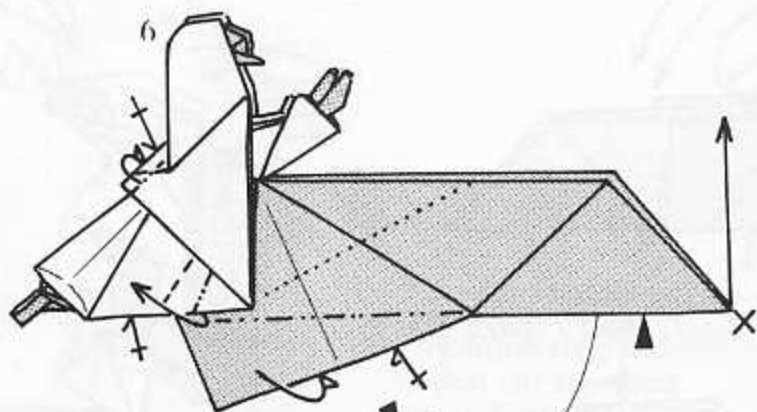

make robe
3D both sides

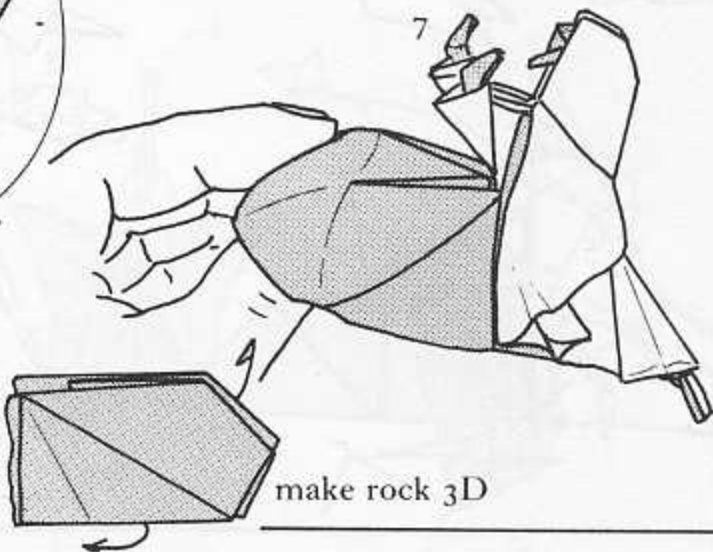
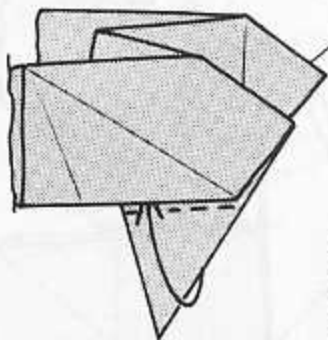
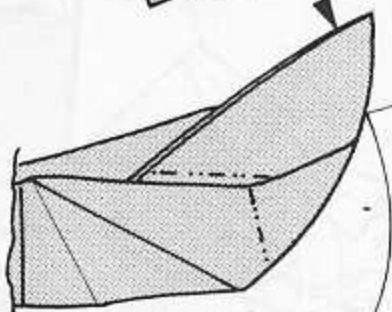

make rock 3D

Swan Patricia Crawford U.S.A.

Begin with a BIRD BASE
(page 9, fold 20).
Stretch the base
both ways to precrease
large thin white square.

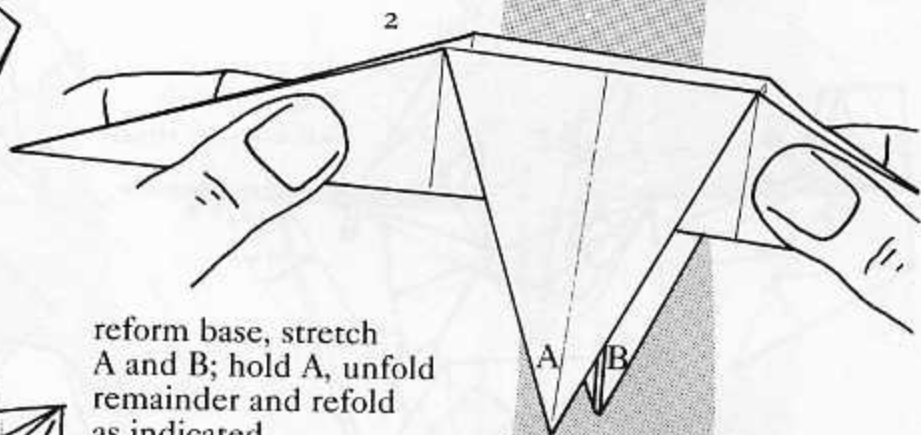
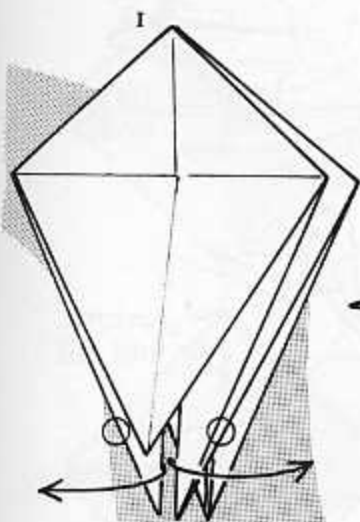
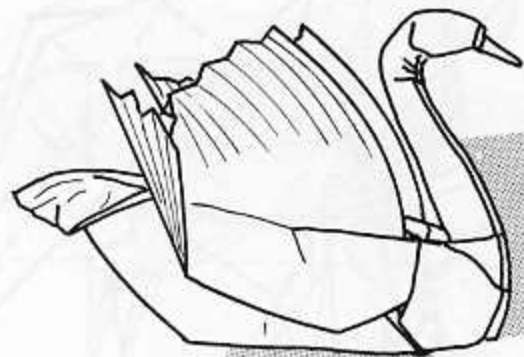

reform base, stretch
A and B; hold A, unfold
remainder and refold
as indicated
(see 3 and 4)

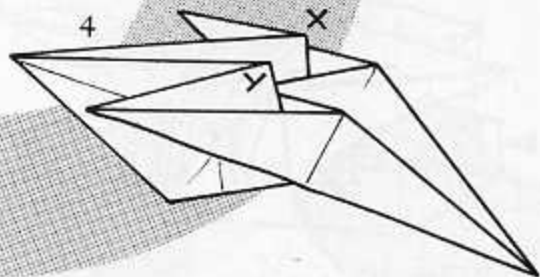
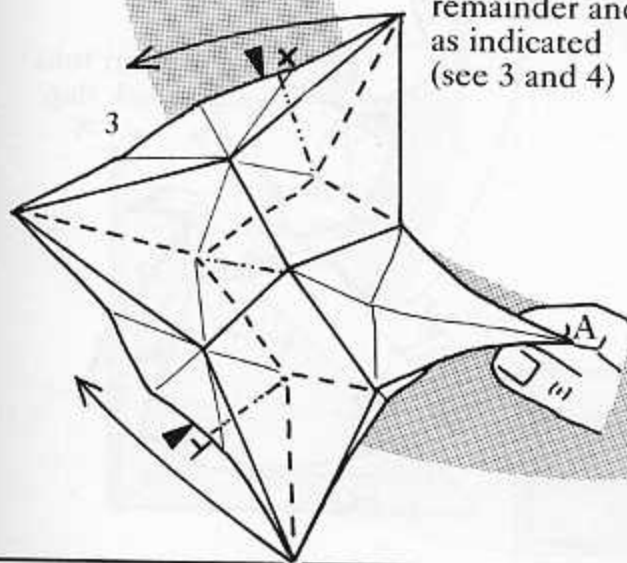

Swan (continued)

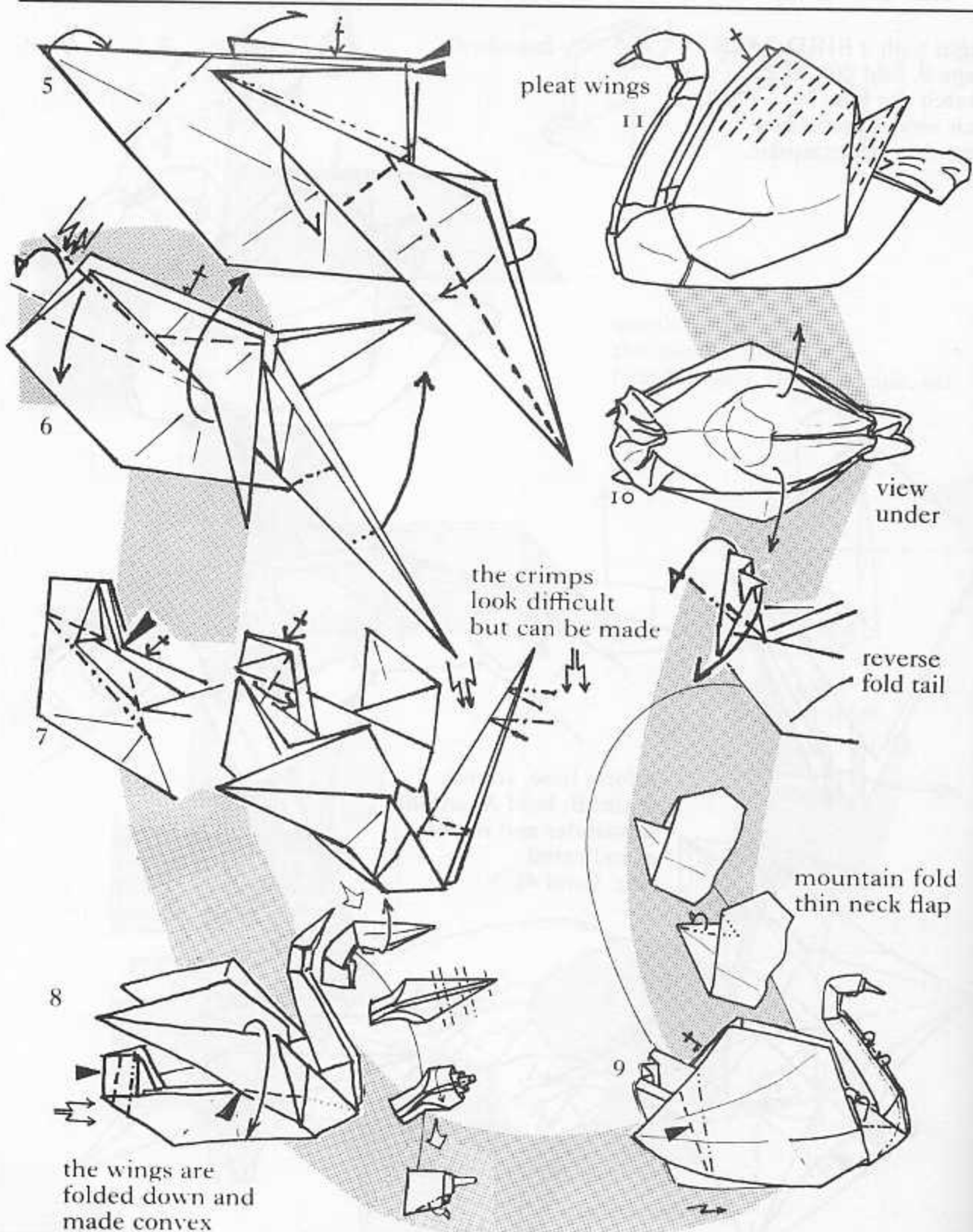

Unicorn Patricia Crawford U.S.A.

Use a square of foil. Begin with fold 2 of the Mermaid (page 42).

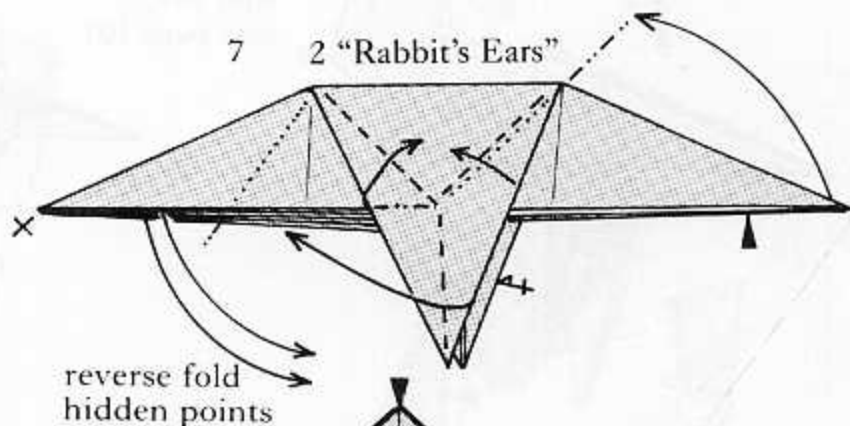
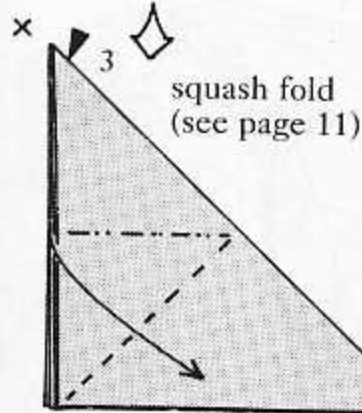
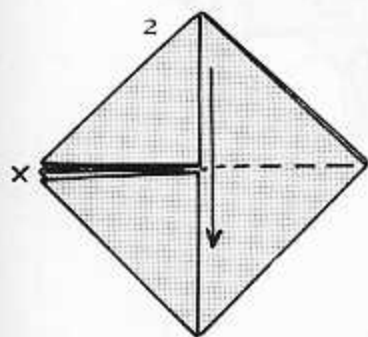
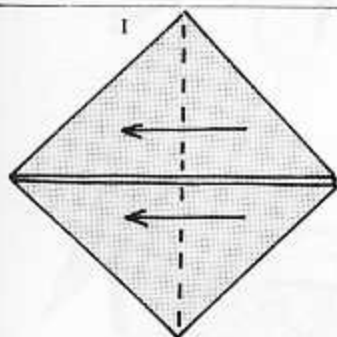
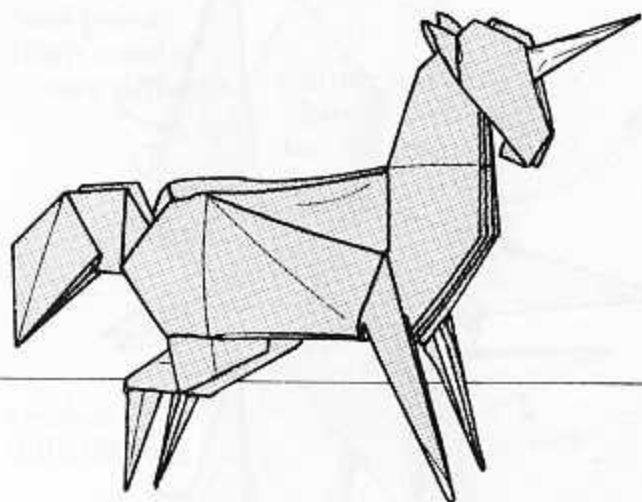

reverse fold
hidden points

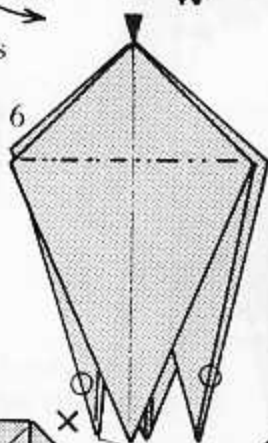

Bird Base
(see page 9)
hold and stretch

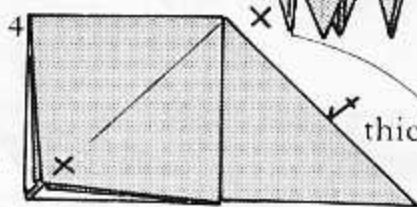

thick side

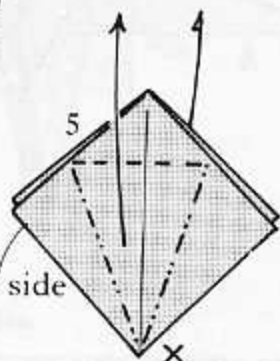

7 2 "Rabbit's Ears"

Unicorn (continued)

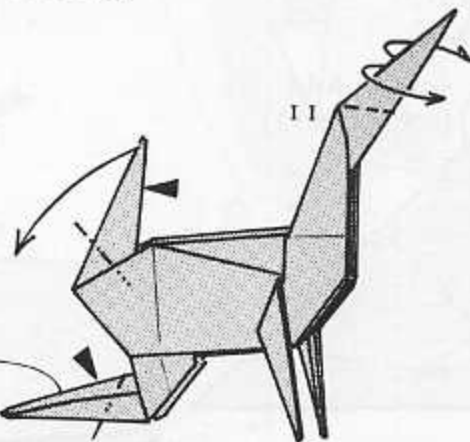
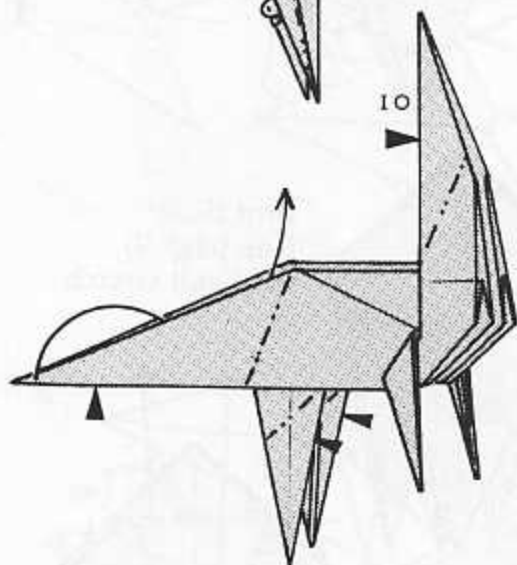
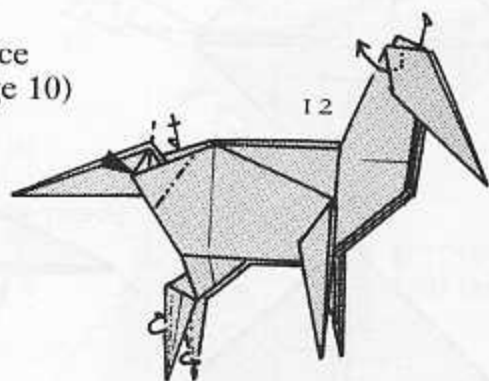
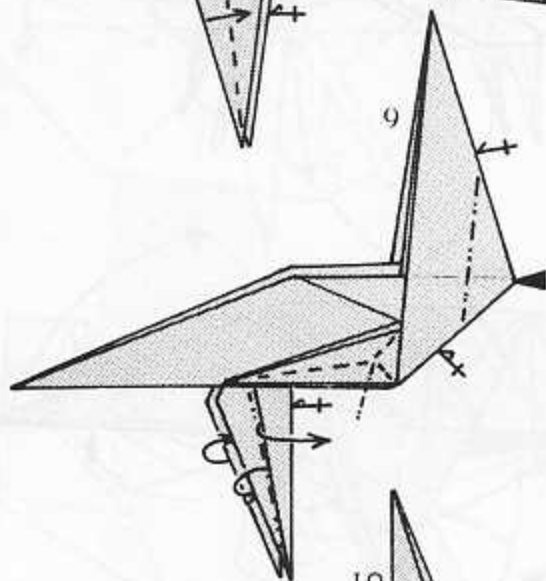
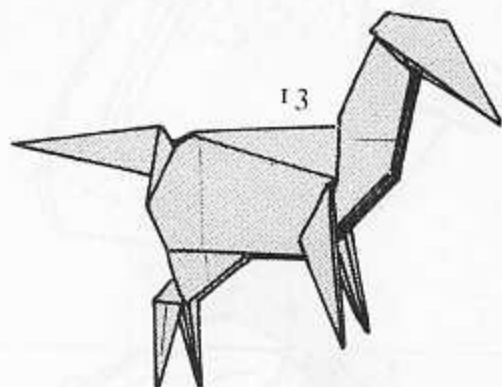
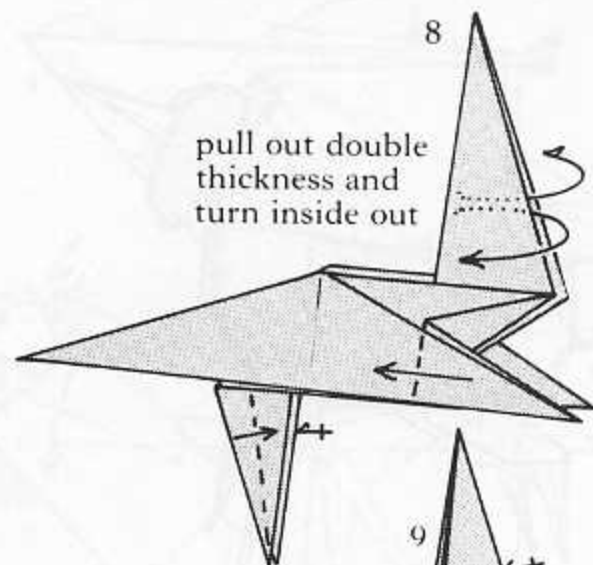

Unicorn (continued)

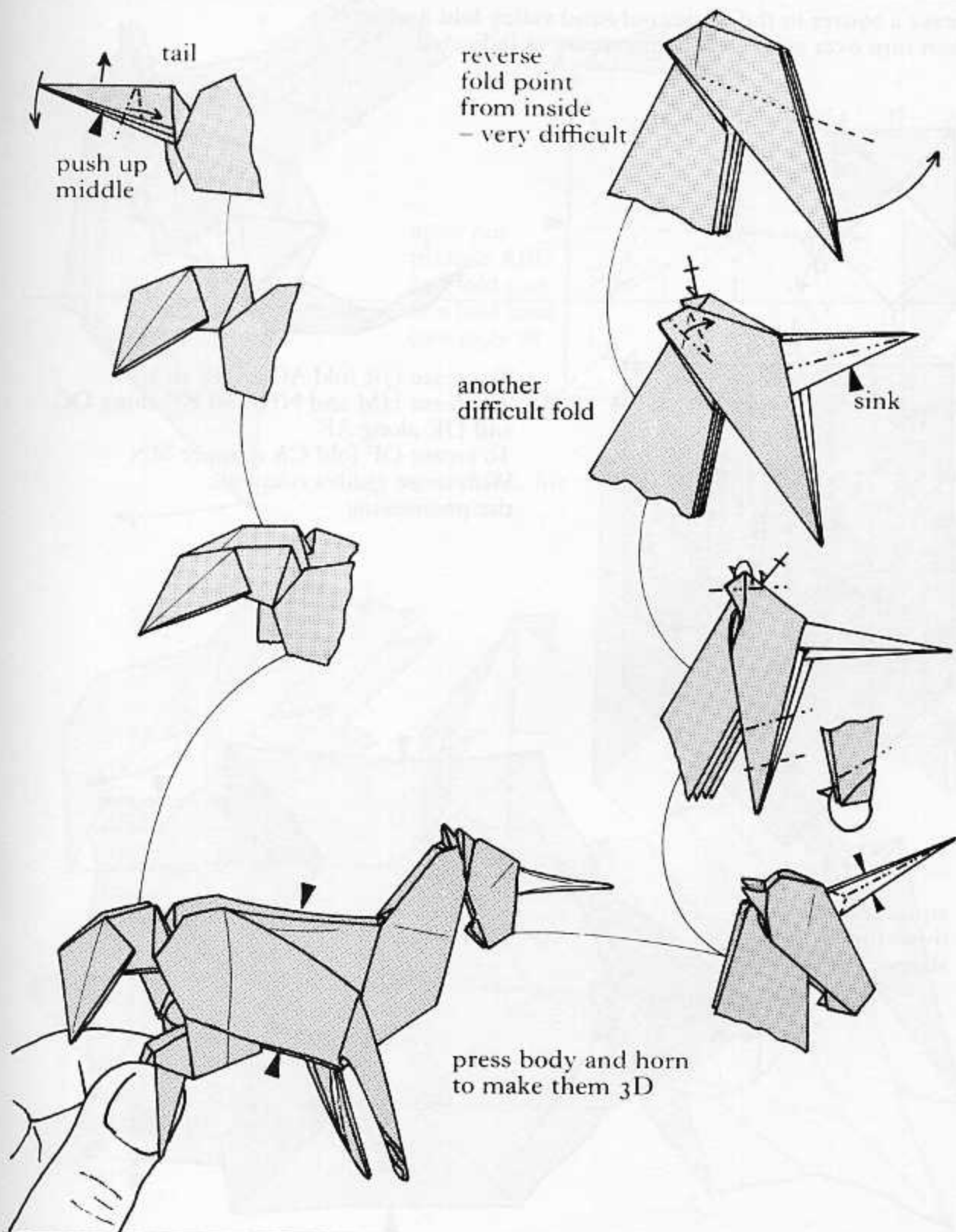

Kangaroo Patricia Crawford U.S.A.

Crease a square in the center only and valley fold 3 corners.
Then turn over and carefully precrease as indicated.

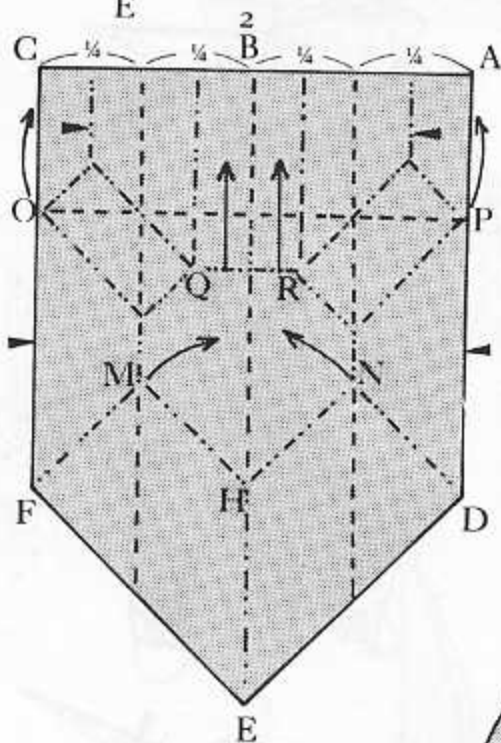
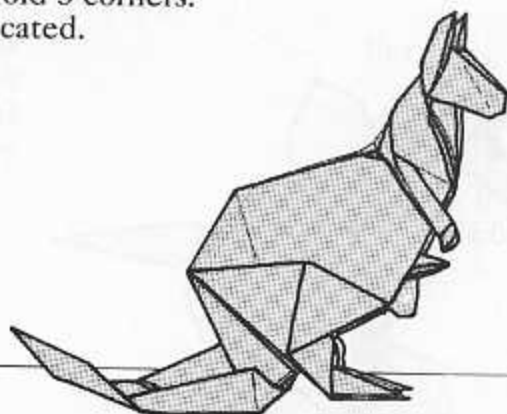
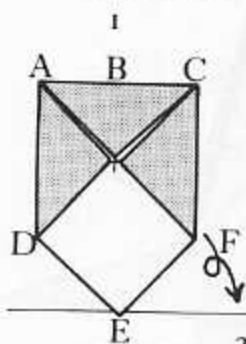

To crease QR fold AC to DF in 1
To crease HM and NH fold EF along DC
and DE along AF
To crease OP fold CA to meet MN
With these guides complete
the precreasing

squeeze the
model into
shape

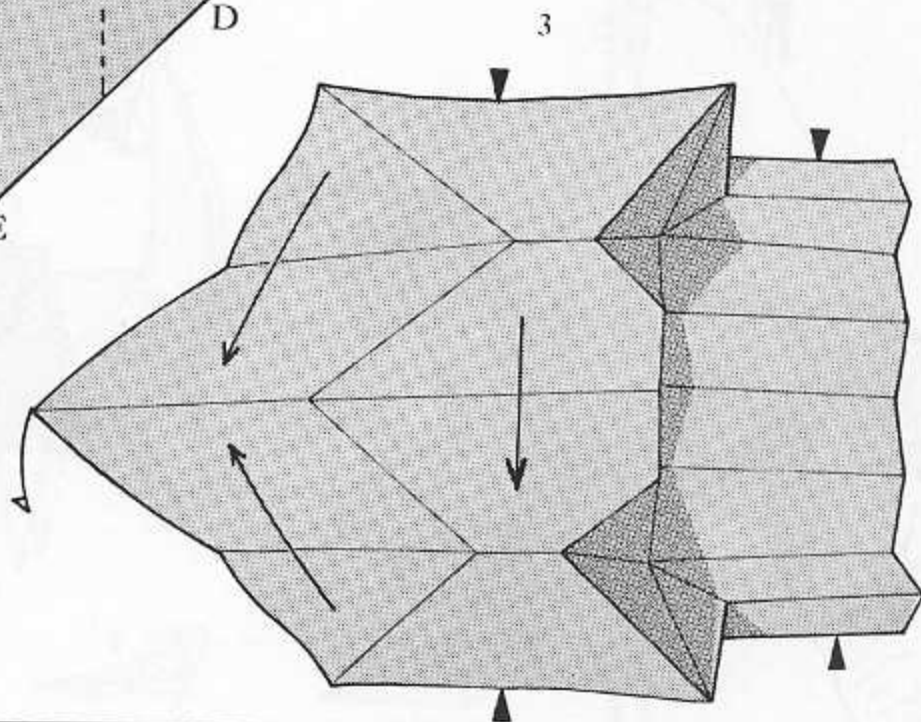

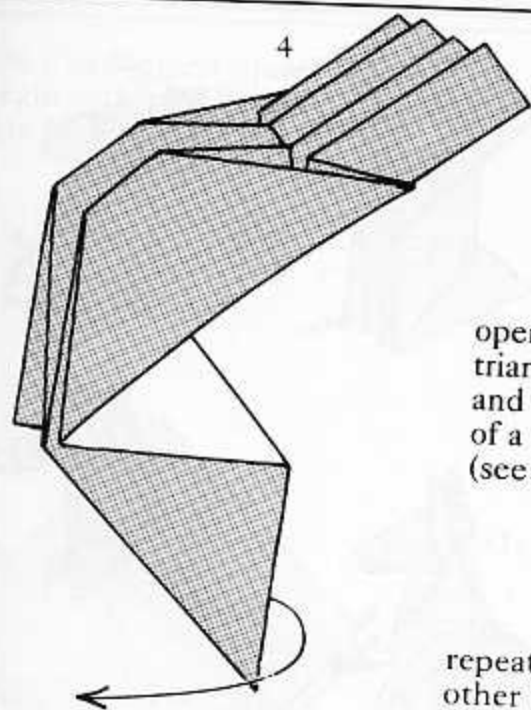

open out
triangle ABC
and fold part
of a bird base
(see page 9)

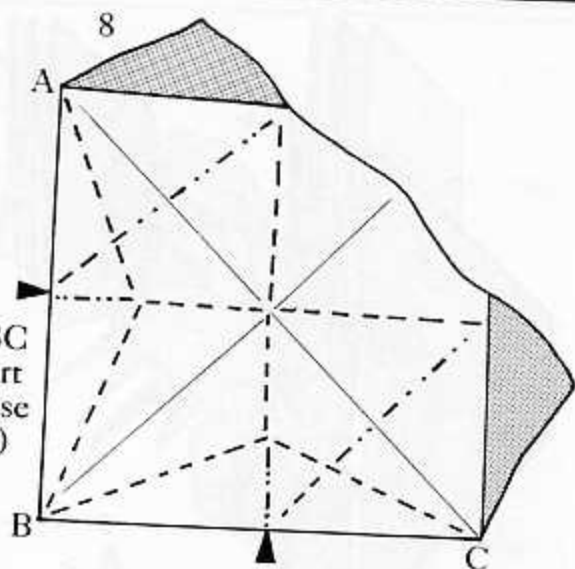

repeat folds for
other ear

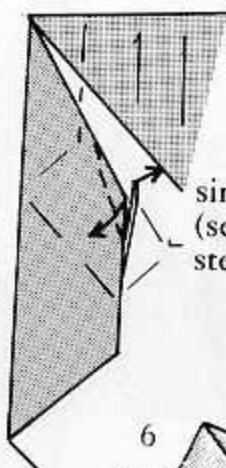
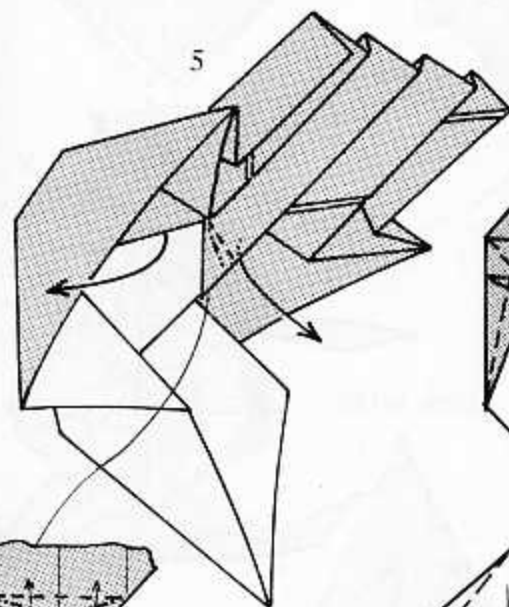

sink 4 corners
(see page 40,
step 10)

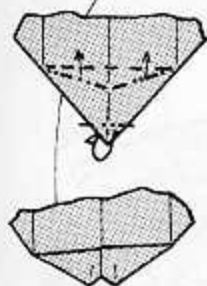
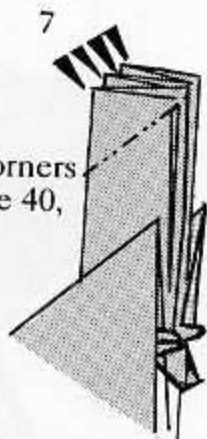

pull out
corners
left and right
to form ears

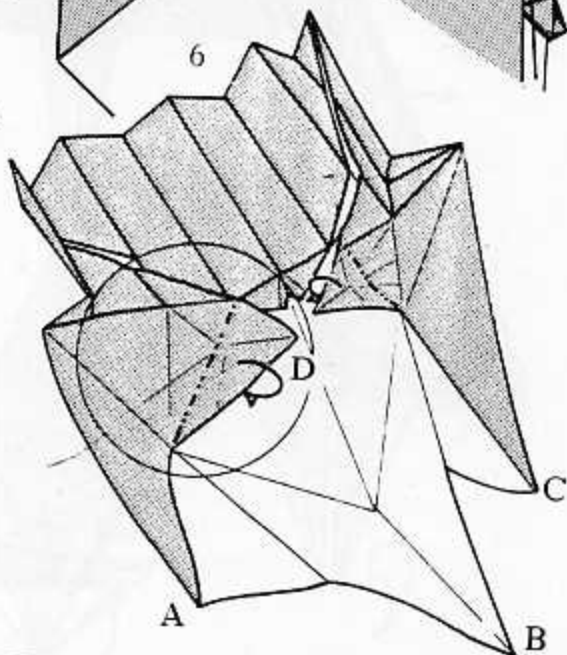
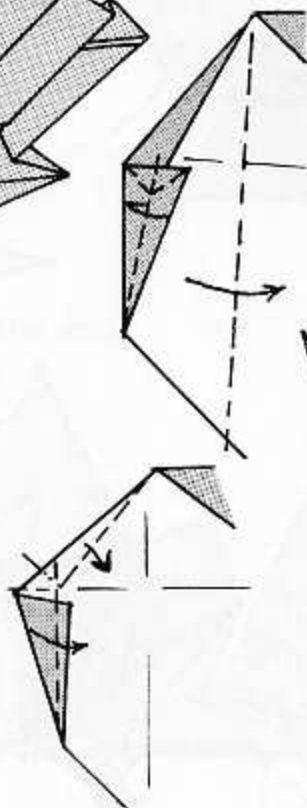

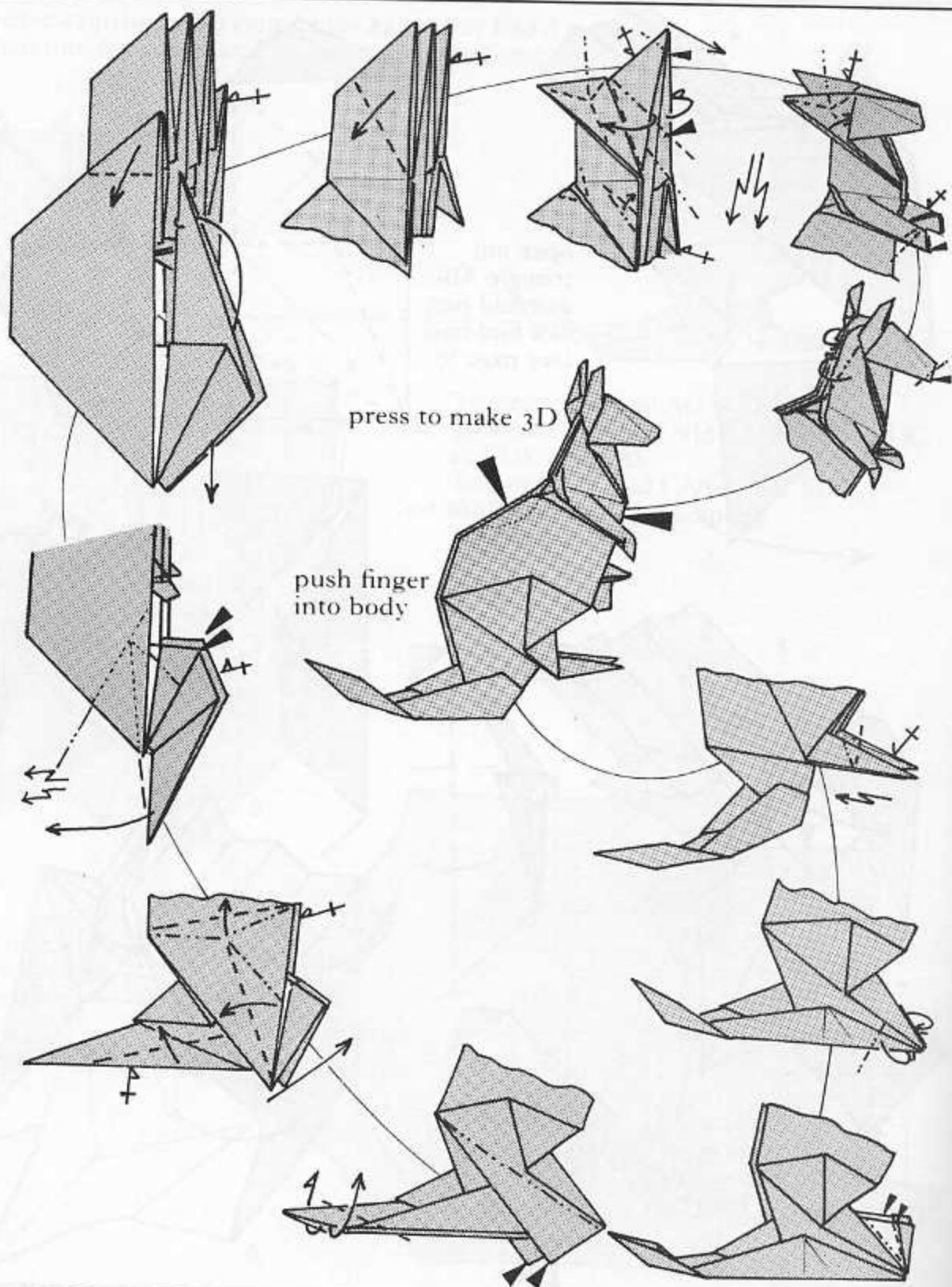

Scorpion Patricia Crawford U.S.A.

Use a dark green square of foil.
Begin with a PRELIMINARY BASE.
(see page 8, fold 9)

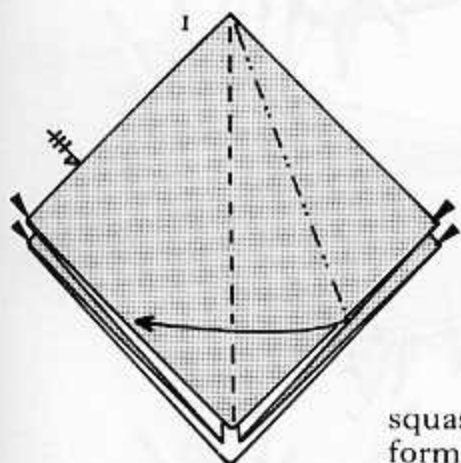

squash 4 corners
form frog base

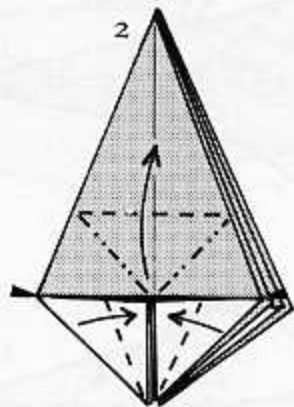

petal fold

push sides in

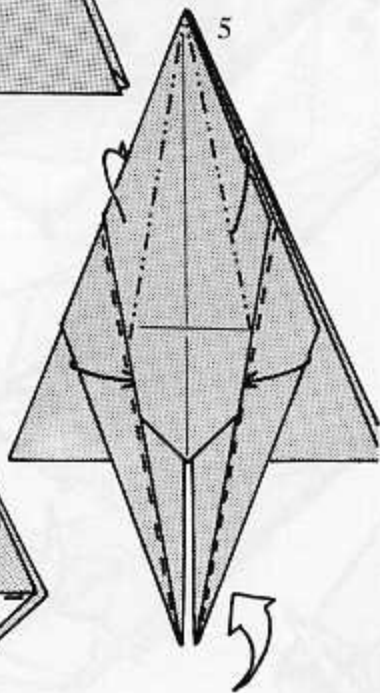
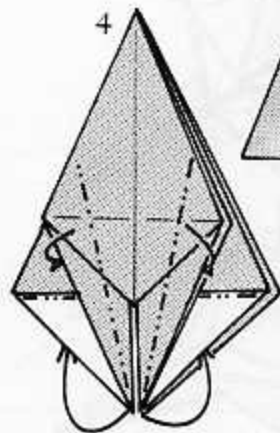
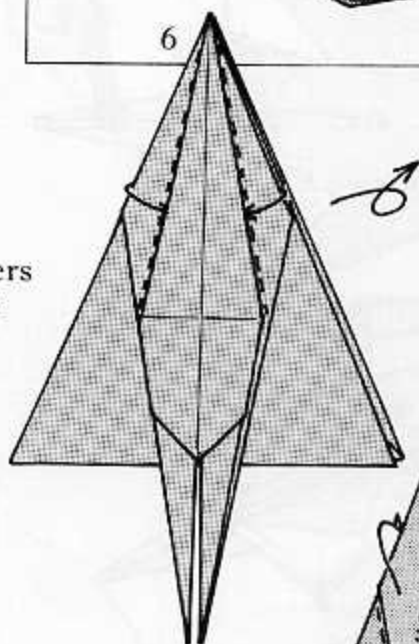
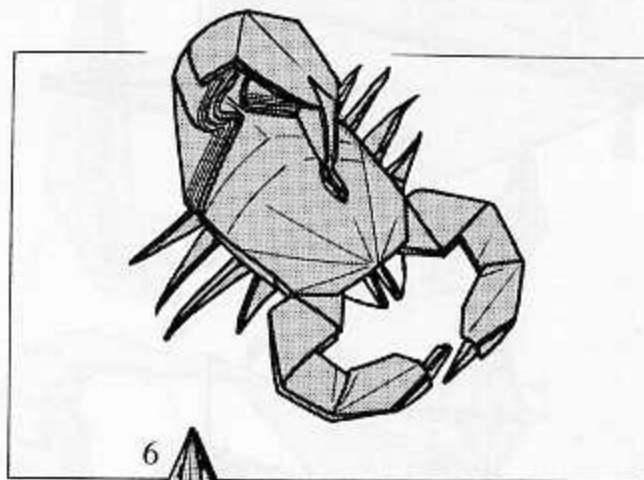
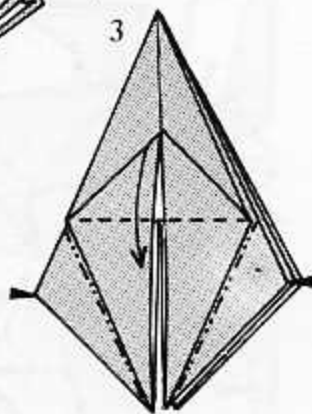

Scorpion (continued)

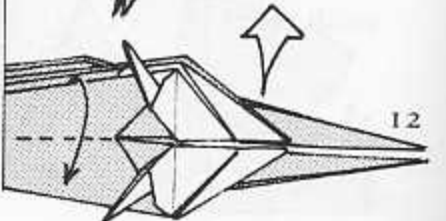
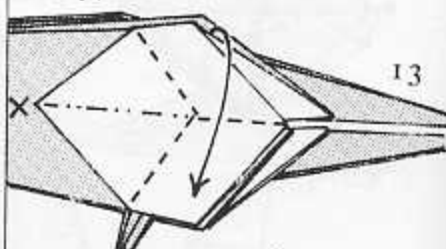
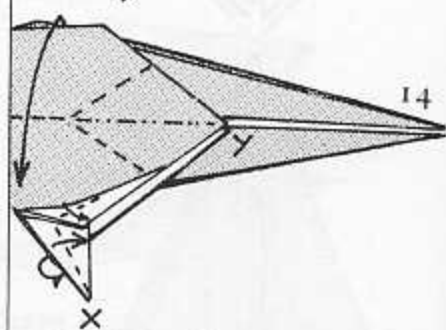
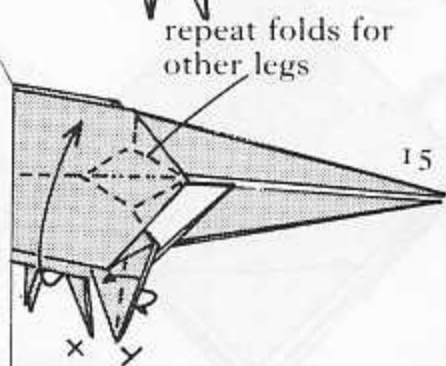
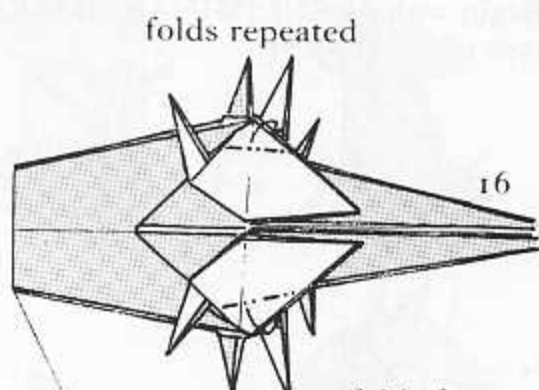
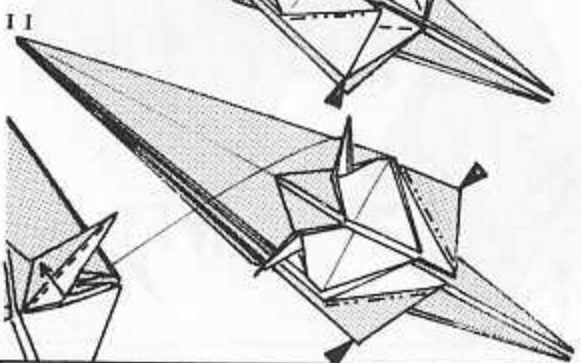
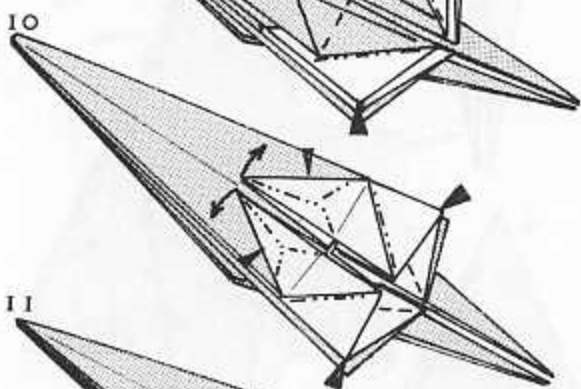
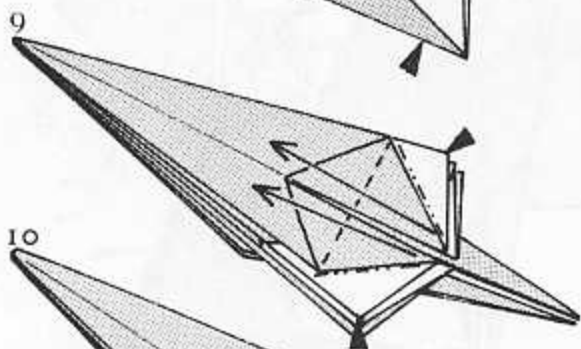
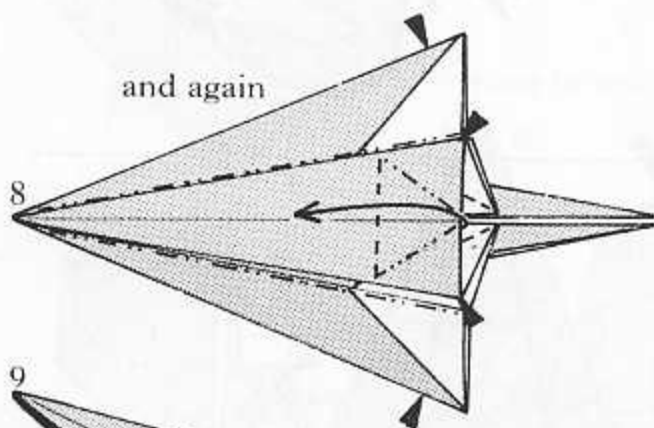
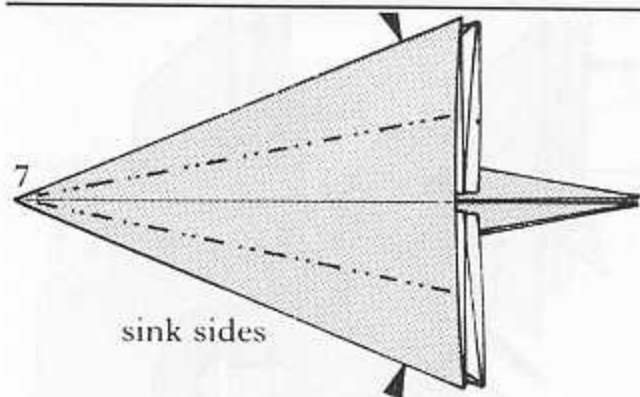

Scorpion (continued)

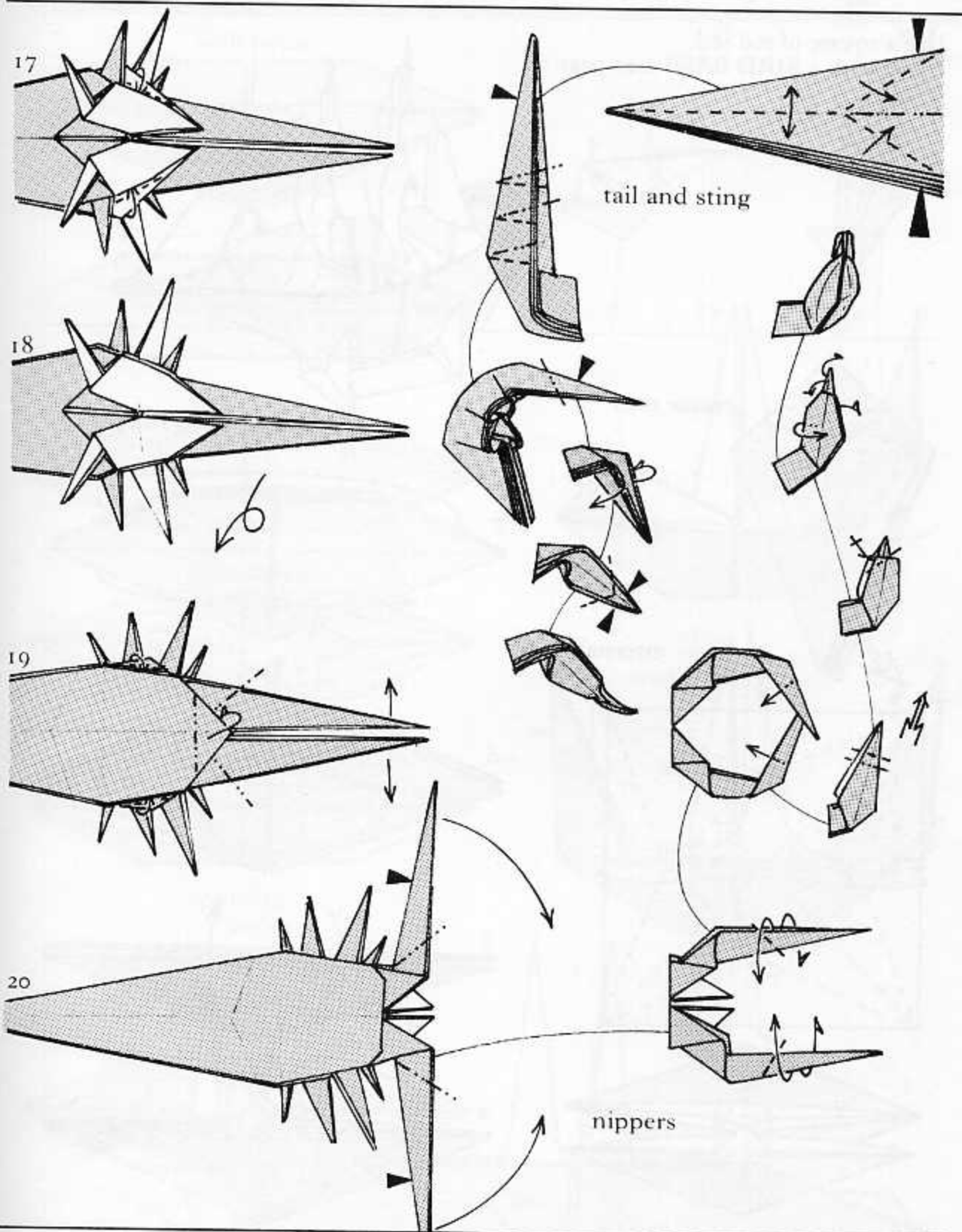

Full-rigged Ship Patricia Crawford U.S.A.

Use a square of red foil.
Begin with a BIRD BASE (see page 9).

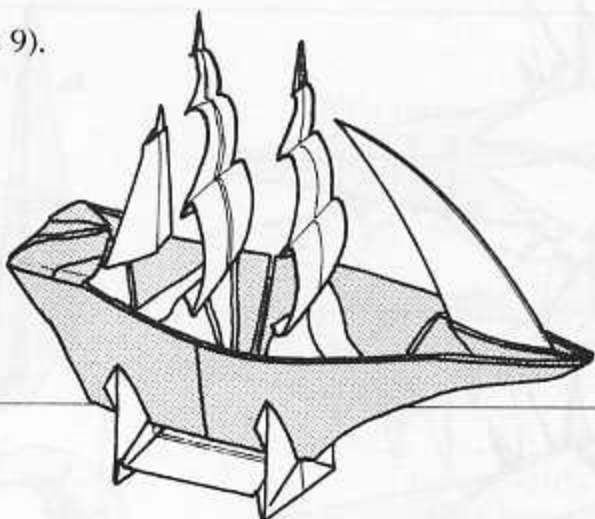

(Base by Fred Rohm)

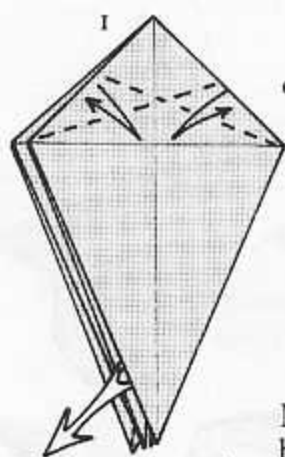

crease only

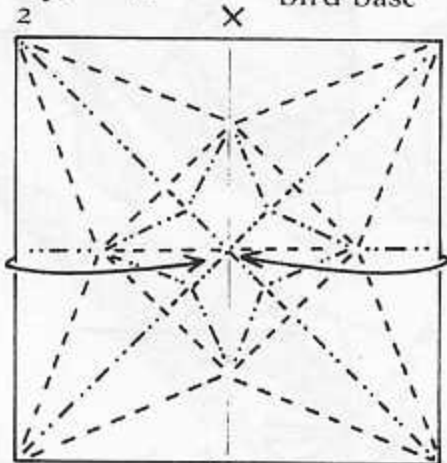

Note internal
bird base

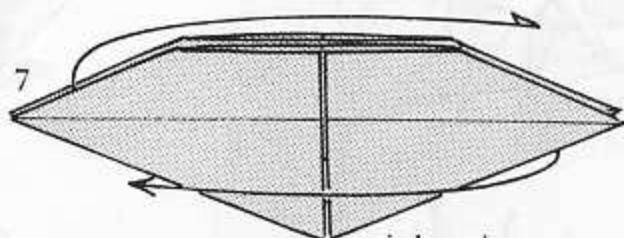
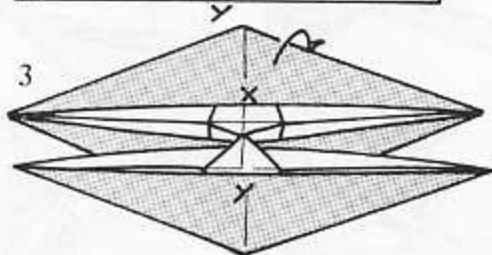

sink twice

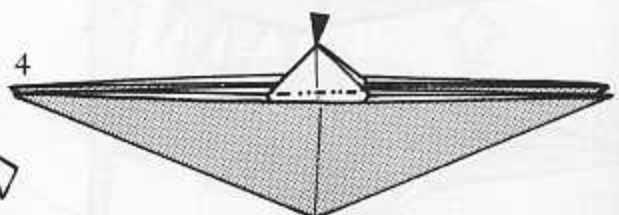
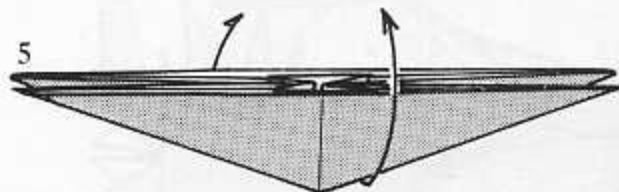
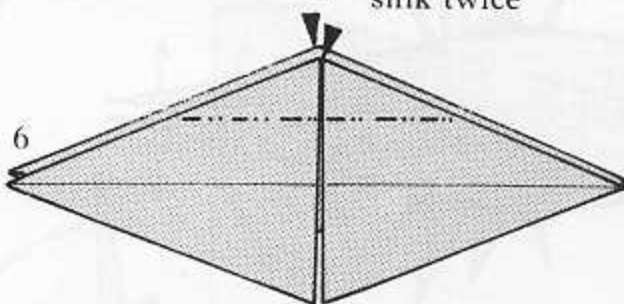

Full-rigged Ship (continued)

sink twice

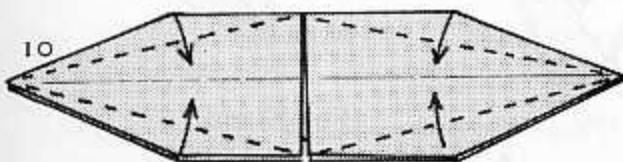
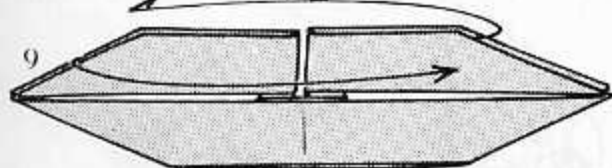
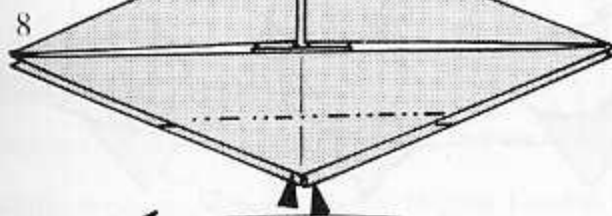

color change

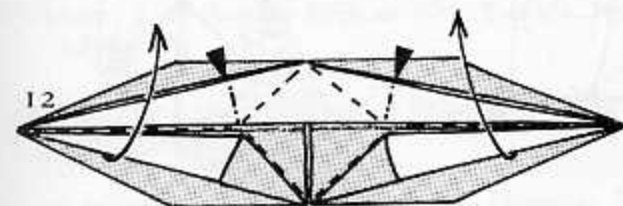
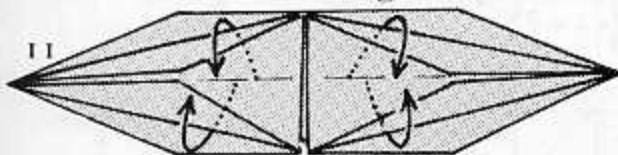
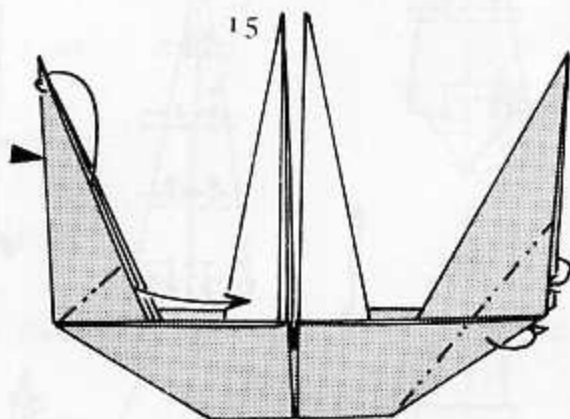
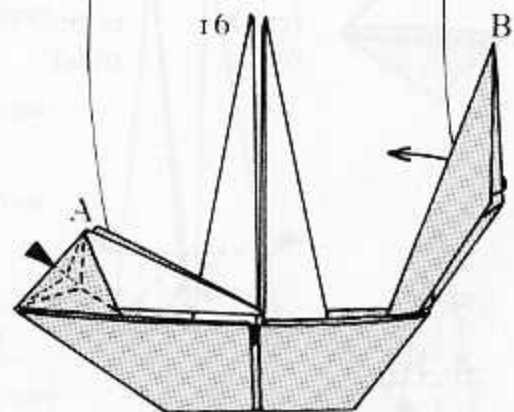
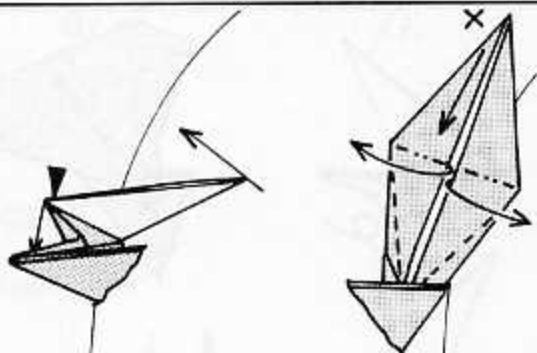
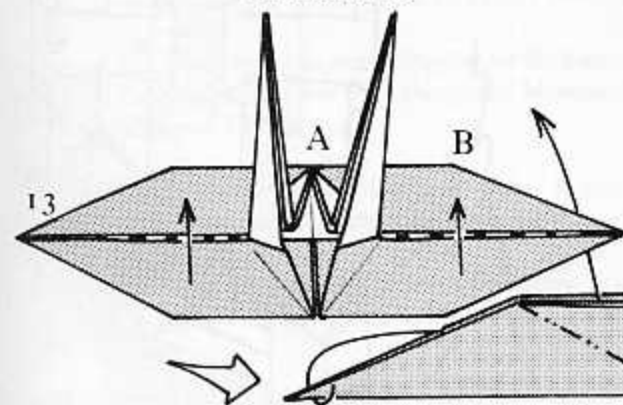
put flap
A under B

14

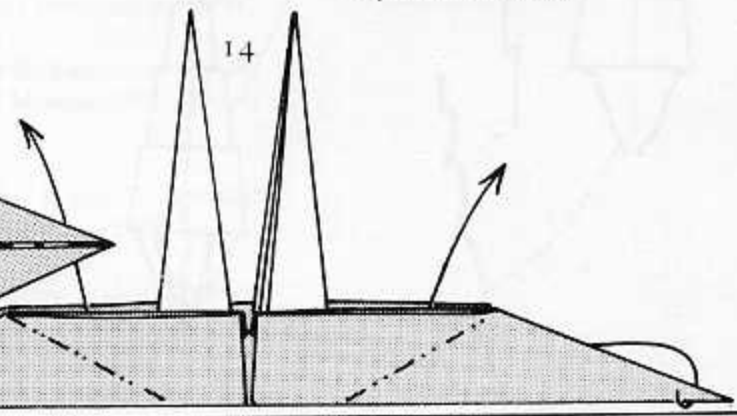

Full-rigged Ship (continued)

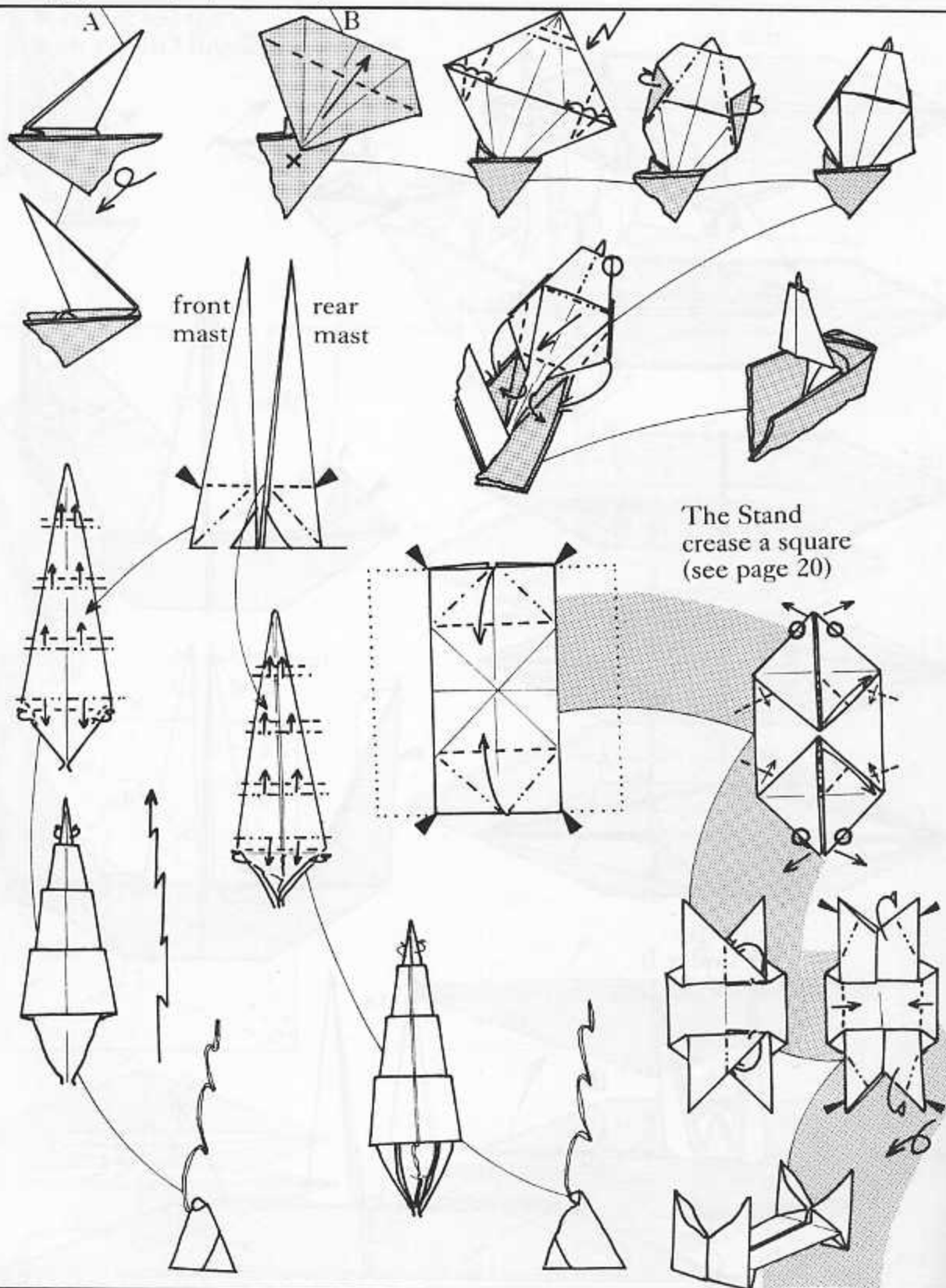

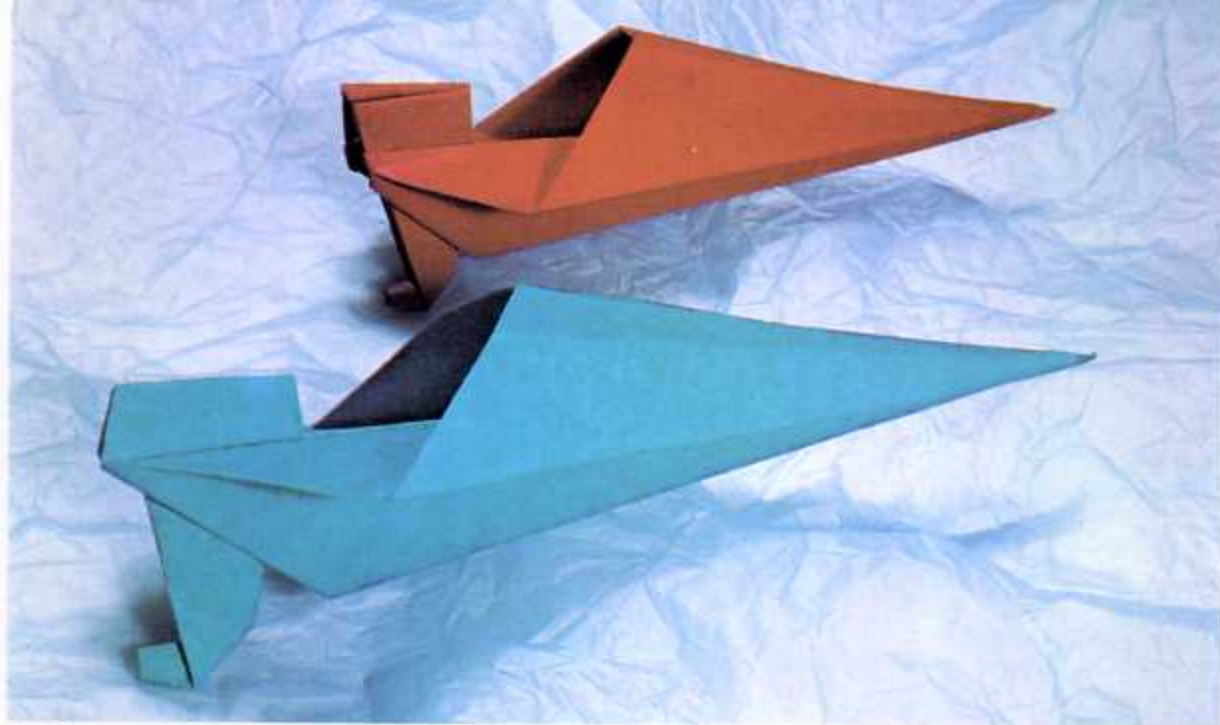

Speedboats, p.22

ORIGAMI

Step by Step

Robert Harbin

This easy-to-follow guide contains all the information paper folders need to create inspired origami models—from learning basic folds to successfully completing a rich assortment of intricate figures.

Readers will find hundreds of detailed, step-by-step diagrams and illustrations of finished paper art that will enable even beginners to fashion such simple objects as a flower, a Japanese box, and a church. Experienced paper folders can hone their skills on such challenging projects as a squirrel on a log, birds in a nest, and a full-masted sailing ship. Among the projects is a selection of wonderfully constructed figures by American origamist Patricia Crawford that will test the abilities of even the most competent paper folders.

In all, over 30 entertaining and inventive projects—including a mermaid, a kangaroo, a film star, nuns, a stalking cat, a unicorn, a tetrahedron, and more—will delight origami fans of all ages and abilities. (Once basic folds and methods have been mastered, folders can attempt original models on their own with ease.)

Revised Dover (1998) republication of the work published by The Hamlyn Publishing Group Ltd., London, 1974, under the title *Origami: A Step by Step Guide*. Reprinted by special arrangement with The British Origami Society. Hundreds of black-and-white illustrations and diagrams. Approximately 10 full-color illustrations on covers. Introduction. Symbols. 64pp. 8 $\frac{3}{4}$ x 11. Paperbound.

ALSO AVAILABLE

SECRETS OF ORIGAMI, Robert Harbin. 8 $\frac{3}{4}$ x 11. 29707-1 Pa. \$12.95

COMPLETE BOOK OF ORIGAMI, Robert J. Lang. 9 x 12. 25837-8 Pa. \$8.95

FASCINATING ORIGAMI, Vicente Palacios. 6 $\frac{1}{2}$ x 9 $\frac{1}{4}$. 29351-3 Pa. \$9.95

Free Dover Complete Catalog (59069-0) available upon request.

See every Dover book in print at www.doverpublications.com

ISBN 0-486-40136-7

On the cover: Scorpion, p.55; Unicorn, p.49; Ship, p.58



\$4.95 IN USA

