

Brilliant

O R I G A M I



A COLLECTION OF ORIGINAL DESIGNS BY

David Brill

Foreword

1978: It's a sunny afternoon and John Smith is driving me back to Southampton. I sit admiring the Sussex countryside, as John proves to be an excellent guide. Naturally the conversation is about folding since we are on our way home from the British Origami Society convention in Birmingham. I ask him a question: "John, who do you consider to be the greatest living folder?" He replies: "Dave Brill".

1994: Late one sunny afternoon I am sitting at home in Paris. Much water has flowed under the bridges of my city and I still agree with John's statement. Dave is great because he is unique. When he creates a model he can already see the finished form in his mind; he has a profound understanding of that form, and his skills as a folder are directed by it. Hence the beauty of his models - his Elephant is a perfect example. Matisse said that the hand must be submissive and obedient to the artist's intent. He also added that the servant must never be allowed to become the master...

Study Dave's models and fold them so that your fingers can appreciate this integrity.

Paperfolding is more than just a recreational pastime adopted from the Far East and intended merely to amuse our children. When one folds a piece of paper, one leaves behind a permanent trace, namely the fold. With the passing of time our joys, our sorrows, our passions and our cares are successively engraved on our faces; we call them wrinkles. Plateau, valley, mountain and depression are some of the words we use to describe our geographical surroundings. It is within the folds and contours of the brain that our ideas are born, and it is the contours of our hands that allow us to caress our loved ones. We will not dwell on the folds of the human heart; they conceal a secret part of us, hidden away within, undisclosed to others. Let us not squander that.

It is important to realize that the very act of folding paper implies a far greater understanding of man and his universe than one might at first imagine. Dave Brill is not content with a superficial view; take any model in this book and you will find it embodies everything we have mentioned.

It is a great honour for a Frog* to talk about a Roast† Beef.

Jean-Claude Correia

Founder of Mouvement Francais des Plieurs de Papier
(French Paperfolders' Association)

(translation: Edwin Corrie)

* Frog: Frenchman

† Roast Beef: Englishman

Preface

This book has been long delayed. While my fellow origami friends and creators have been swift to make collections of their designs, I have not followed suit. This is for many reasons, and is despite many hard-to-ignore demands from those who have appreciated my work. But finally I have managed to clear my desk and set aside any excuses for not getting down to the job. I apologize deeply to those who have waited for too long and I hope that they will find their patience has been in some way rewarded.

I began my acquaintance with origami in my childhood through the innocent pages of Alfred Bestall's Rupert Annuals. As I continued to learn more designs, and to acquire new origami books, I realized that origami was for me the perfect activity. No complicated tools or equipment are required, and the raw material is the most easily obtainable: the simple sheet of paper. It was not until I made contact with the British Origami Society in the mid 1970's, meeting Martin Wall and Max Hulme, themselves already accomplished creators, that I was moved to design my own original models. A thrilling period of friendly rivalry followed where the three of us tried to out-do each other with new techniques and challenges. In any creative sphere, one is stimulated by the ideas of others, and I am the first to admit that my work is a distillation of other people's designs. I freely acknowledge my debts to my talented colleagues. However, frequently I have drawn inspiration from areas other than origami, such as architecture, geometry, art and nature. I encourage all potential origami creators not to wear blinkers! Seek your ideas everywhere.

The present richness of origami has, I believe, been accentuated by its inherent restrictions: either the established but unwritten rules such as "no cuts, no glue, no paint", or the personally adopted ones: in my case these include "economy, three dimensionality and avoidance of classic geometry." I like to draw the analogy between origami styles and the richness of cigarette advertising, which also is restricted almost to the point of censorship. Here in England the adman's ingenuity to overcome these restrictions has been taxed to its maximum, and the results are always cryptic and stimulating.

I believe my origami work provides a bridge between the styles seen in the West: analytical, highly detailed and engineered; and the Eastern approach: minimal and artistic. Thanks to the lessons learned from my painting teacher, Alan Thompson, I have tried to emphasize the form of the whole rather than home-in on details. The danger is to think that the whole subject is the sum of its parts and to fold each of these in precise representation. This approach leads to awkward designs, lacking integrity. To overcome this temptation I have learned to step back from my work periodically, or to hold it at arms length, to judge the overall effect, much as a painter will view his own work in the making.

In my work I have tried (not always successfully) to cultivate a sensitive touch, always to have respect for the paper, and never to ask it to do more than it is able.

This "touch" is a thing lacking in the work of many Western folders, whose work can be contorted and ugly. I admire those origami artists whose work is finely executed: anyone can appreciate delicacy and finesse, but sadly they are things rarely seen.

In conclusion I sincerely hope you enjoy folding the designs featured in the following pages. The work has been long and painstaking, but ultimately hugely rewarding for me.

Dave Brill



CHIPOLLO.INFO



Gift Box (p.46), Box and Lid (p.54)



"Woven" Strip Dodecahedron(p.82), and Double Cubes (pp.90 and 92)

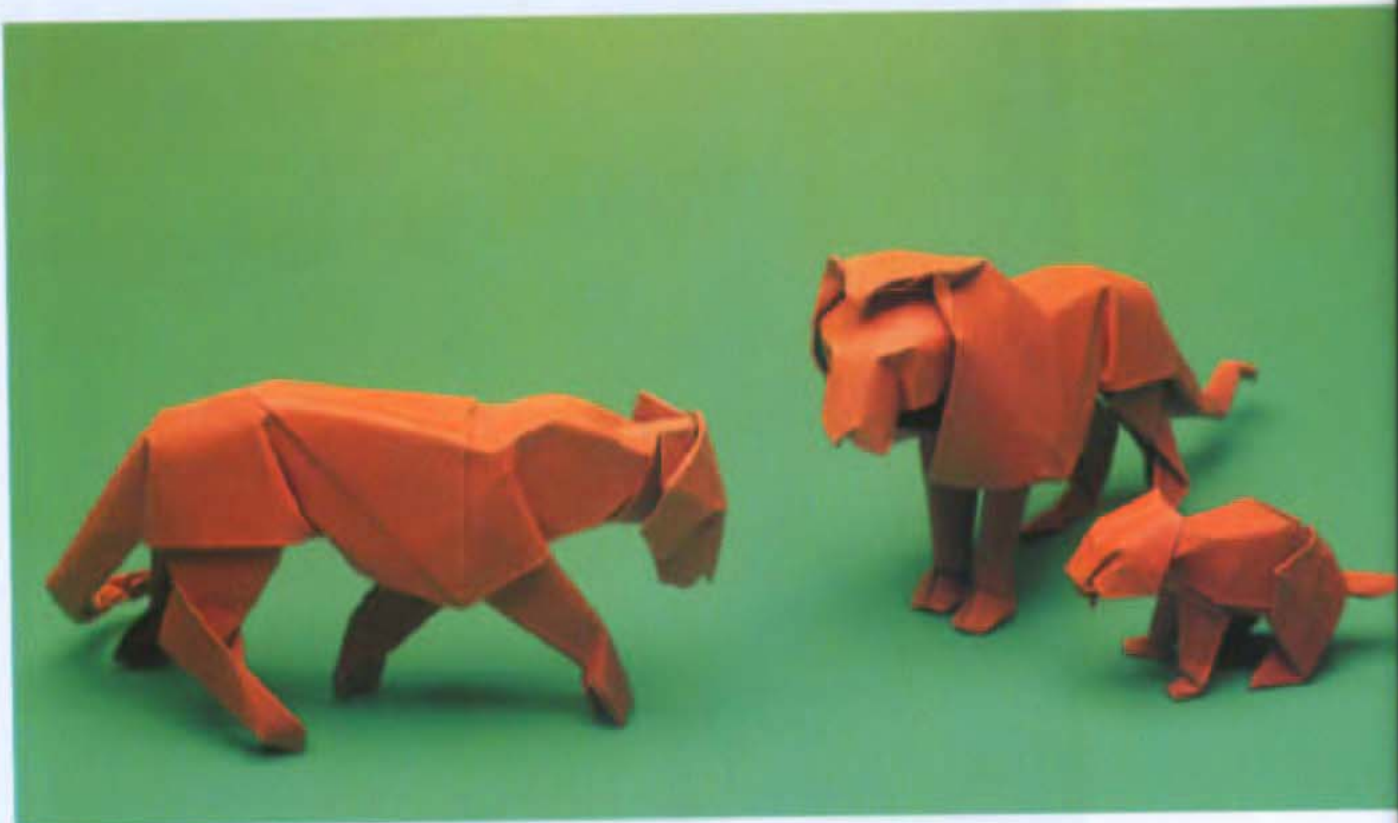

Lioness, Lion and Lion Cub (pp. 150, 159 and 163)



Rhinoceros (p.135)



Horse (p.168)

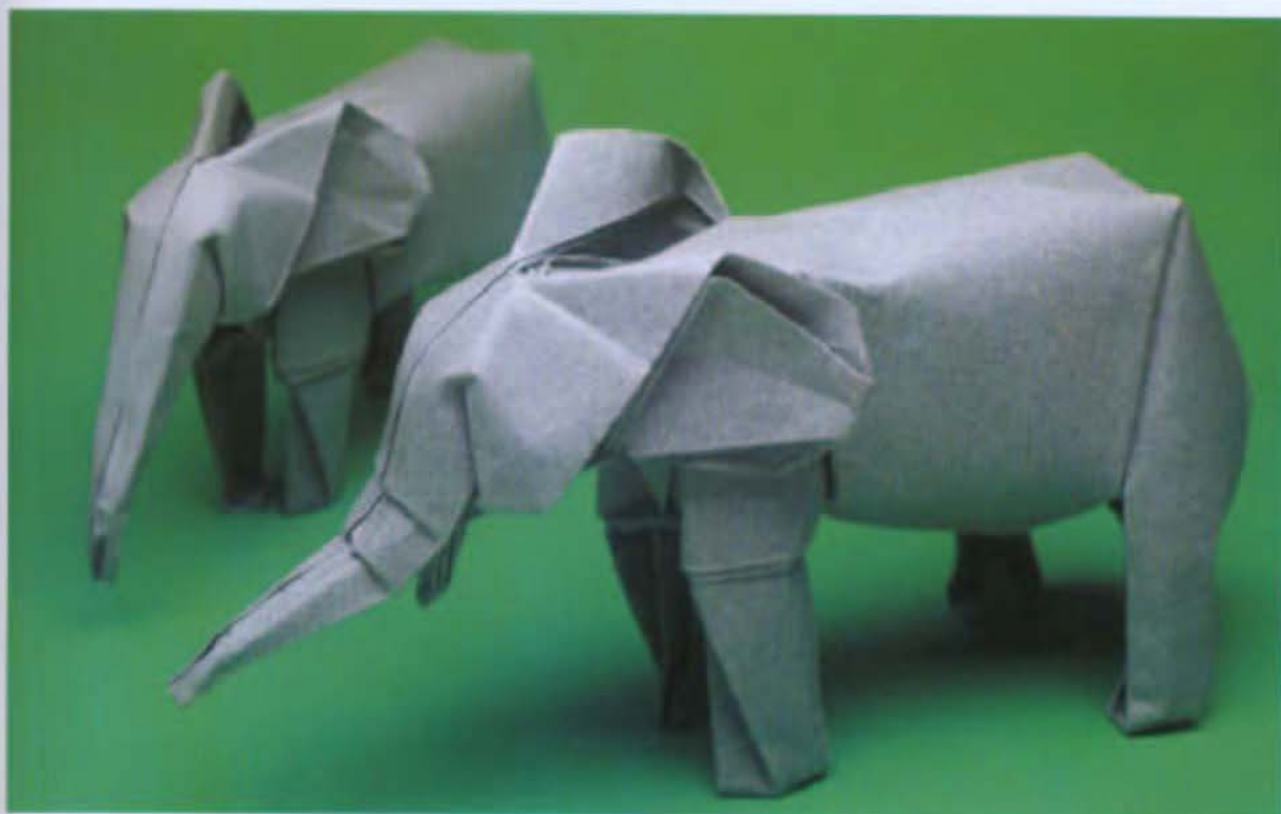

Elephant (p.140)



Fox Hunt (pp.123, 125 and 128)

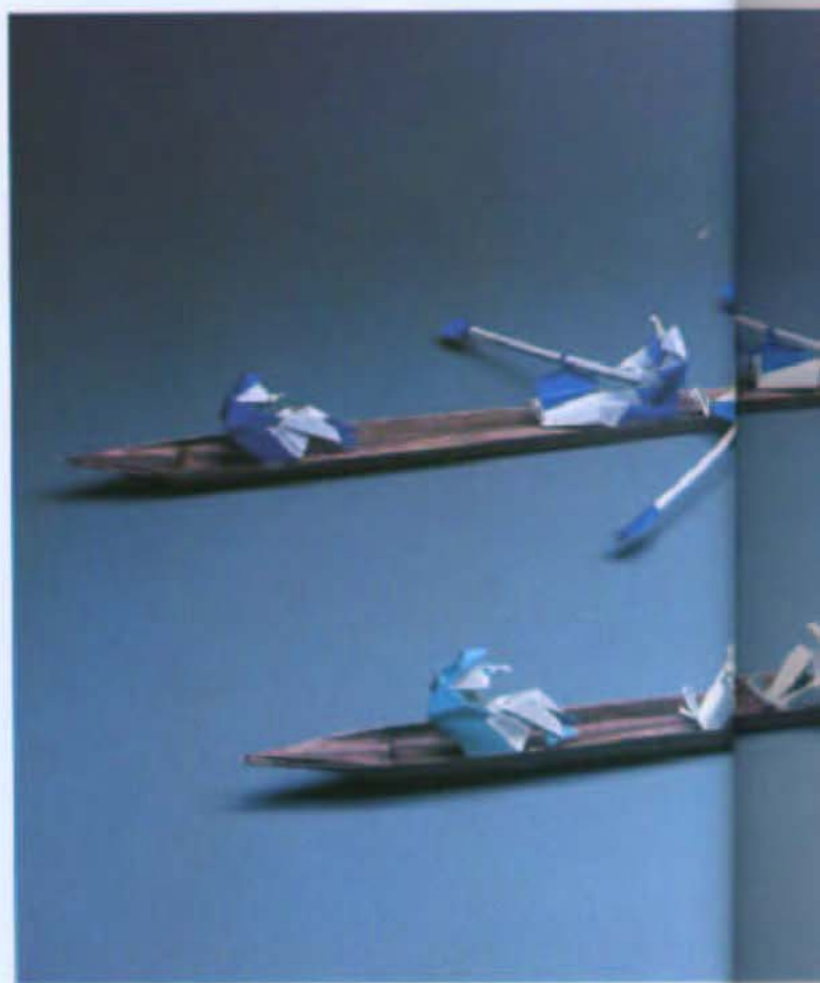

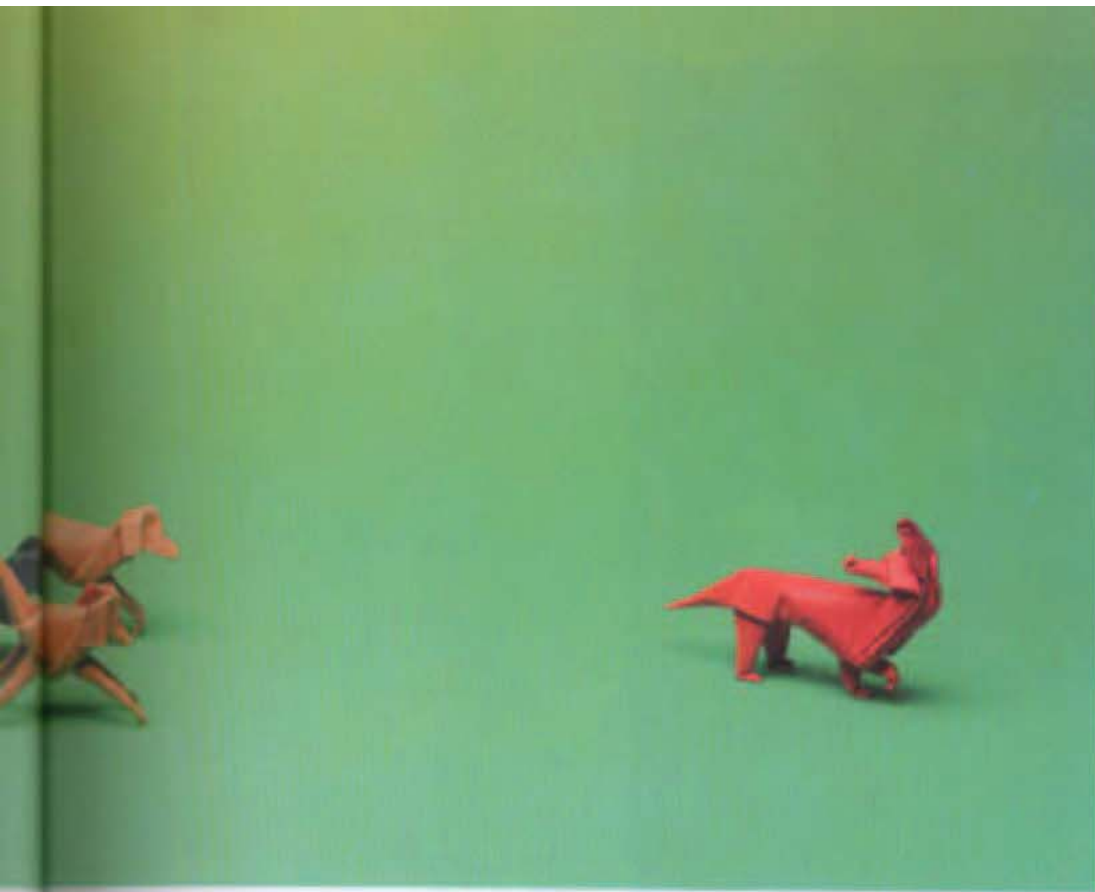

Oxford and Cambridge Boat Race (pp.198–201)



**Geppetto, Pinocchio (pp.216 and 220) and
Spelling Book (p.224)**



Hallowe'en Witch (p.210)



Christmas Tree Fairy (p.183)

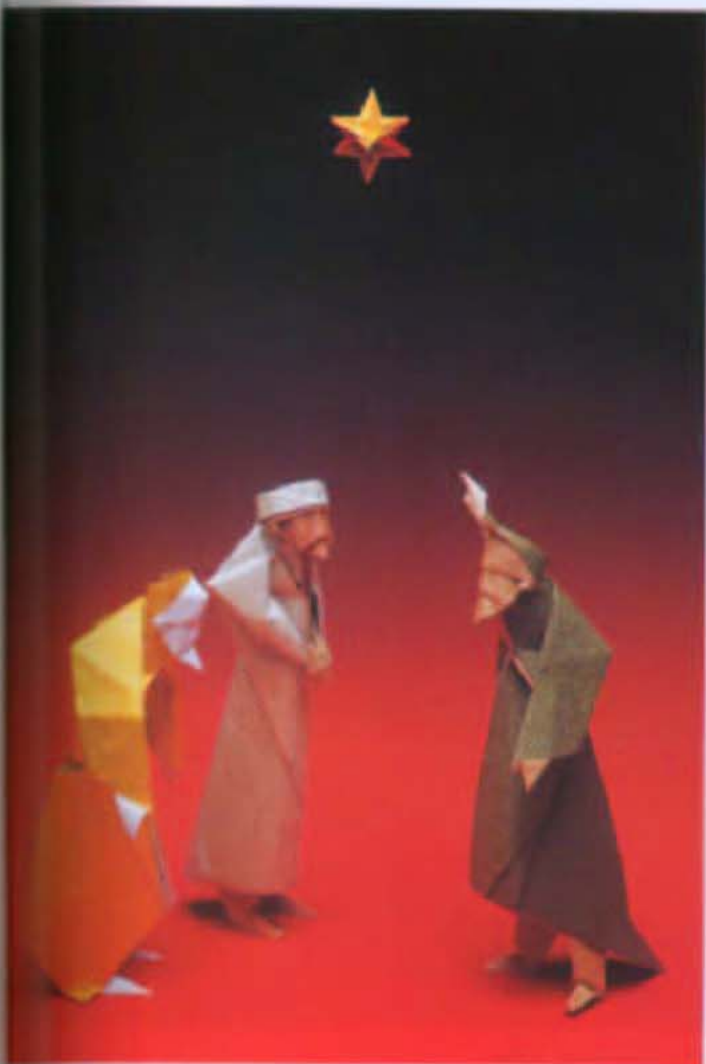

Three Wise Men (pp.204–209)



Show Jumper (p.212)



Father Christmas, Reindeer and Sleigh (pp.193, 228 and 230)

Acknowledgments

Thanks are due to the following friends and supporters for the help and encouragement they have given me during the preparation of this book:

Humi Huzita, for putting me in touch with the publishers, and insisting that I start the work in the first place;

Kunihiko Kasahara and Tomoko Fuse, for assuring the publishers of my good intentions;

Jean-Claude Correia, for his broad viewpoint and open mind;

David Petty, for his painstaking proof-reading;

John Smith, for his critical approval of my work;

Paul Jackson, for helping me to remove my "blinkers" from time to time;

Max Hulme and Martin Wall, for their friendly and encouraging rivalry;

Neil and Hazel McAllister, for the meticulous photographic work;

Doreen Montgomery, for her advice with the complexities of the publisher's contract;

The late Iwao Yoshizaki, his successor Yukishige Takahashi, Toshihiro Kuwahara and Akiko Shibata of Japan Publications, Inc. who have demonstrated so much faith in me;

All my friends in the international origami movement who have shown appreciation for my work;

The British Origami Society which has given me so many opportunities in the origami world.

I thank you all deeply.

CONTENTS

- Foreword* 5
Preface 7
Acknowledgements 17
Signs and Symbols 20
Symbols and Suggestions 21
The Silver Rectangle, A size paper and The $\sqrt{2}$ proportion 22
- Toys and Working Models 23
Emu 24
Exhibitionist 26
Book 28
Walking Man 30
Spectacles 34
Talking Fox 35
Nut and Bolt 36
Thoughts on Diagramming 43
- Boxes and Containers 44
Pentagonal Envelope 45
Gift Box 46
Star Container 46
Bottle 50
Yacht 52
Box and Lid 54
Cigarette Packet 58
Matchbox 62
Money Box 64
Honeymoon Box 67
- Modular Origami 70
Modular Theories 71
The Rhombic Dodecahedron and its three Stellations 73
Sunken Silver Cube 74
Sunken Silver Icosahedron 75
Sunken Silver Star 76
30 Point Sunken Star 78
Dimpled Silver Dodecahedron 79
Silver Dodecahedra 80
"Woven" Strip Dodecahedron 82
True Woven Dodecahedron 83
Stellated Dodecahedron 84
- Stained Glass Balls 85
Spiky Star 87
Double Cube 90
Venetian Double Cube 92
Waterbombic Dodecahedron 96
Double Star Flexicube 98
Wet Folding Techniques 104
- Animals 105
Lamb and Corgi 106
Mouse 108
Guinea Pig 110
Rabbit 111
Goose 114
Squirrel 119
Foxhound 123
Fox 125
Horseman 128
Rhinoceros 135
Elephant 140
Square versus Equilateral Triangle 149
Lioness 150
Lion 159
Lion Cub 163
Horse 168
Dragon 172
Rules Traditional and Personal 178
- Human Figures 180
Mask 181
Christmas Tree Fairy 183
Crown 187
Wand 188
Father Christmas and his Sack 191
Father Christmas 193
Basic Form for Figures 197
Oarsman 198
Seat and Rowlock 199
Oar 200
Boat 200
Cox 201
Three Wise Men 204
Wise Man I 206

Wise Man II	207
Wise Man III	209
Hallowe'en Witch	210
Hat	210
Broomstick	211
Showjumper	212
St George	214
Spear	215
Shield	215
Geppetto	216
Pinocchio	220
Spelling-Book	224
Groups and Scenes	225
Ashtray	226
Reindeer	228
Sleigh	230
Square Silver Star	232
Rotating Double Cube Series	233
Single Cube	234
<i>Ideas for Creative Approach</i>	235
Contacts	236
Bibliography	237
Index	239

Signs and Symbols

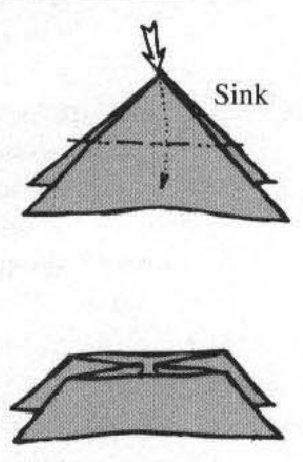
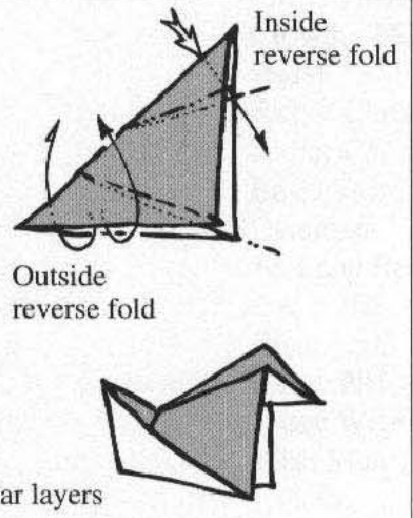
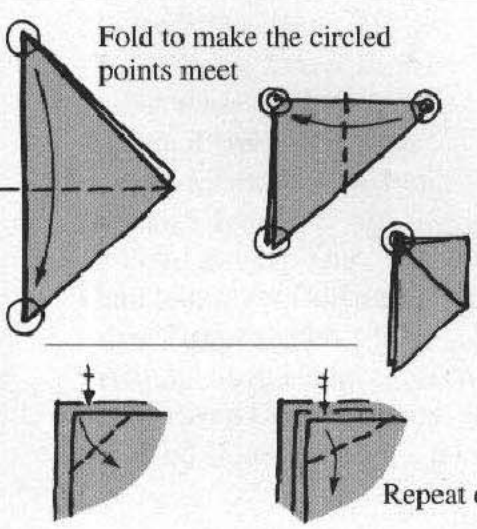
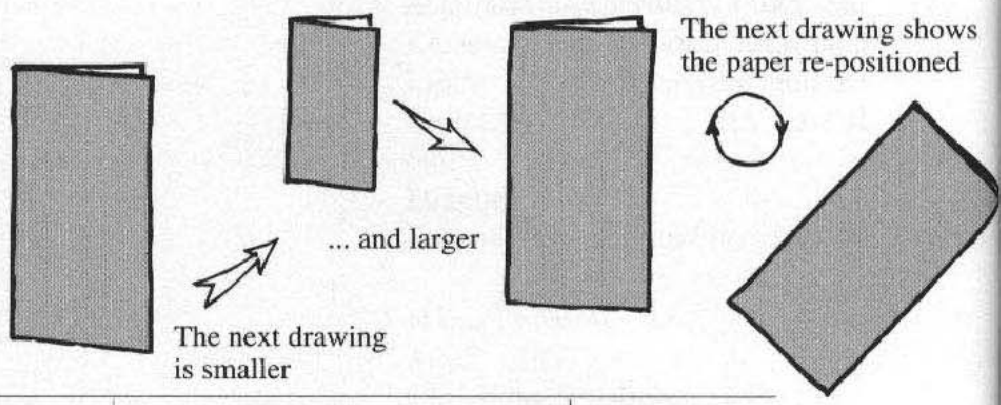
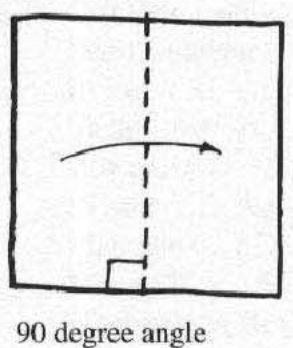
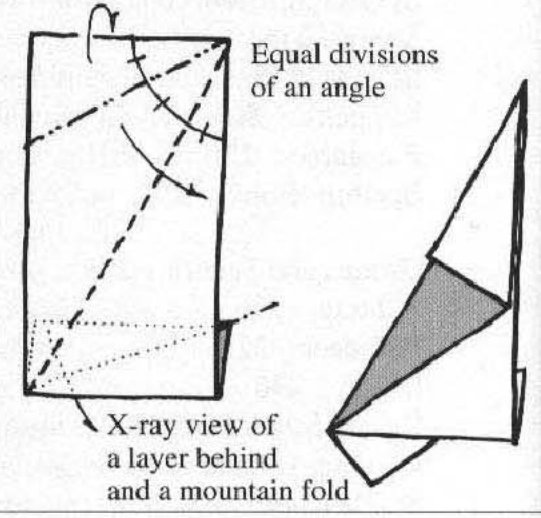
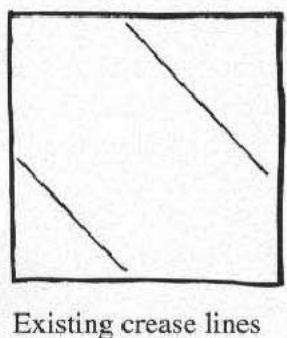
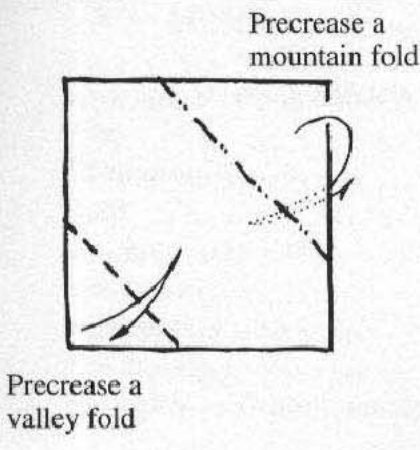
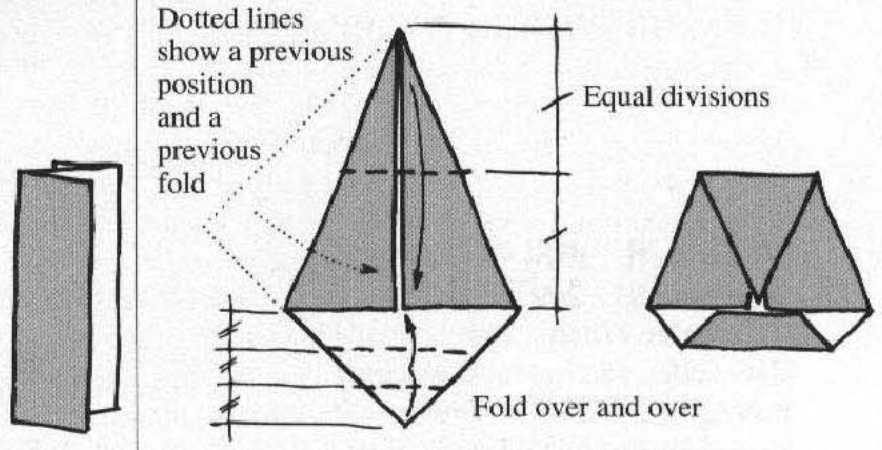
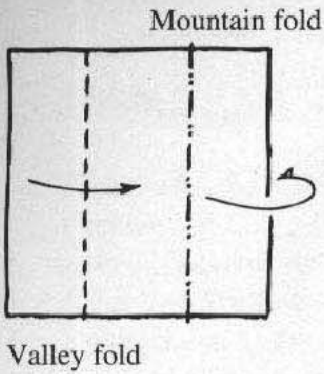

Symbols and Suggestions

Although the level of the work included in this book may appeal more to the experienced folder, who should be well acquainted with the standard folding symbols which are used internationally, I nevertheless feel it is appropriate to include some word of additional explanation at this point.

I believe that the symbols pioneered by Akira Yoshizawa in Japan, and continued in the West by Samuel Randlett and Robert Harbin, do offer the best means available of describing a way of folding an origami design. There must be doubts, however, about the overall effectiveness of drawings like this for the beginner, who frequently is discouraged when faced with apparently complicated diagrams and symbols. But again this is not a book that will necessarily fall within the scope of a novice paper-folder, although I hope that those new to origami may find something worth trying.

For the sake of uniformity, I have not introduced new symbols, but you may notice some slight variations to the norm. For example I have not always included the repeat symbol as it should be quite obvious in a symmetrical design that a manoeuvre has to be repeated on similar flaps, or on the layers behind.

Akira Yoshizawa's practice of folding in the air, rather than on a flat surface is an attractive principle for me. This means that you are fully in contact with the paper, and are not hindered by the apparently "comforting" surface of the table. Nevertheless, the need to have the support of a flat surface in the early stages of the folding of a large design with a sizeable sheet, will at times be essential. You'll be able to pick up the paper when it becomes more manageable in the later stages.

When folding living creatures, it's worth remembering that precision in the final stages may not always be appropriate. In fact it can be worth experimenting with handling the paper quite roughly in order to obtain a more naturalistic result. Another small point: when it's necessary to run a crease between two points, I find it easier to "squeeze in" a mountain fold. If a valley fold is attempted then invariably the points you are trying to connect are obscured.

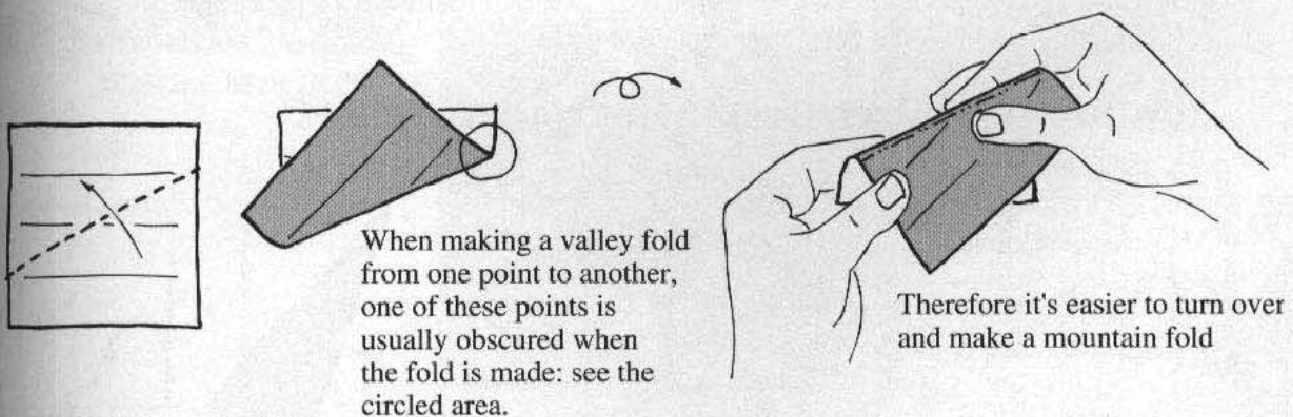

You should certainly be aware of all the paper types which you come across, experimenting with them to explore their folding suitabilities. Paper is all around us, and you should not feel it essential to use commercially manufactured origami paper. Types of paper for which I have a particular fondness include common brown wrapping paper which gives the impression that the finished design has been made from wood. Fabriano paper, from Italy, which comes in a variety of weights, is good for wet folding, which I'll describe later. Canson from France has similar qualities, and the available colours are brighter.

The Silver Rectangle, A size paper, and the $1:\sqrt{2}$ proportion

There are many references in this book to "A" size paper. Although "A4" is well known internationally as the standard paper size, in the USA, paper measuring 8 1/2 x 11 inches is commonplace.

The relationship between the sides of all "A" papers is described geometrically as $1:\sqrt{2}$. This means that the long side of the rectangle is equal to the diagonal of a square, whose side is equal to the short side of the rectangle. A useful benefit of this rectangle is that if it is folded in half, short side to short side, then the smaller rectangle obtained has the same proportion as the original, and is also in the ratio $1:\sqrt{2}$.

Also known in the origami world as The Silver Rectangle, this paper size is useful to the practising paperfolder for many reasons. It is widely available and thus needs no advance preparation. You'll realise from the above that if you need a smaller version of the design you are working on, it's a simple matter to start from a sheet cut in half. The term Silver Rectangle has given rise to many of the titles of the constructions featuring in the *Modular Origami* section of this book, for example the Dimpled Silver Dodecahedron, and the Sunken Silver Star.

The measurements of "A" rectangles are based on metric units, the largest size in common use being A0, equivalent in area to 1 square metre. To help you make the paper size for various designs in this book, here are the measurements of each of the "A" rectangles. Remember though, that if you have an A4 sheet, you can make an A5 by simply cutting it in half.

Size	Inches	Centimetres	Size	Inches	Centimetres
A0	43 3/4 x 33 1/8	118.8 x 84.1	A4	11 3/4 x 8 1/4	29.7 x 21.0
A1	33 1/8 x 23 3/8	84.1 x 59.4	A5	8 1/4 x 5 3/4	21.0 x 14.8
A2	23 3/8 x 16 1/2	59.4 x 42.0	A6	5 3/4 x 4 1/4	14.8 x 10.5
A3	16 1/2 x 11 3/4	42.0 x 29.7	A7	4 1/4 x 2 7/8	10.5 x 7.4

To form a Silver Rectangle from a U.S. sheet measuring 8 1/2 x 11 inches, all you have to do is cut a 5/8 inch wide strip from the long side. This will not of course be an exact "A" rectangle but will have the correct proportions of $1:\sqrt{2}$.

How to cut a Silver Rectangle from any sheet

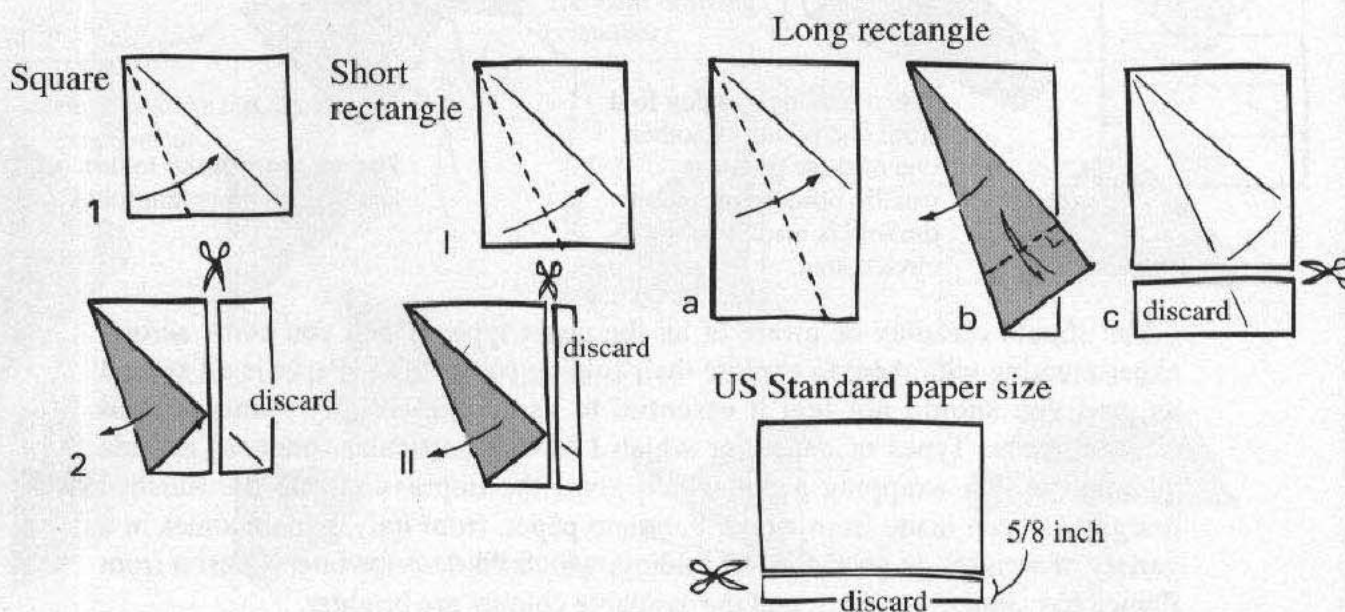

Toys and Working Models

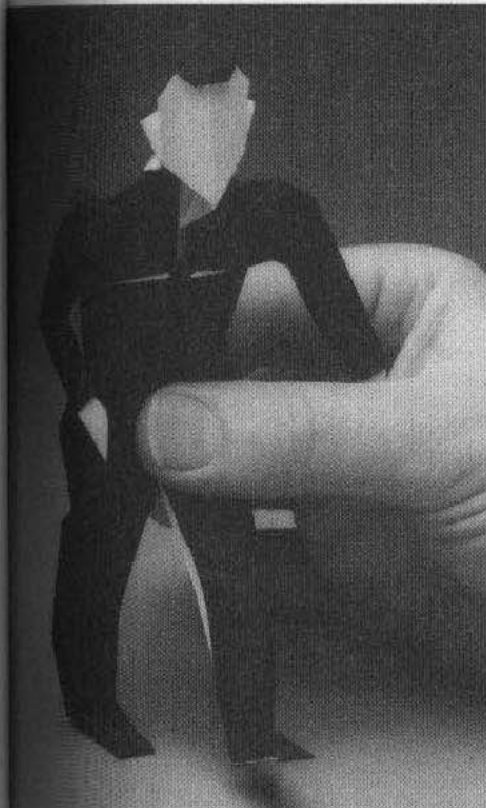

Walking Man (p.30)

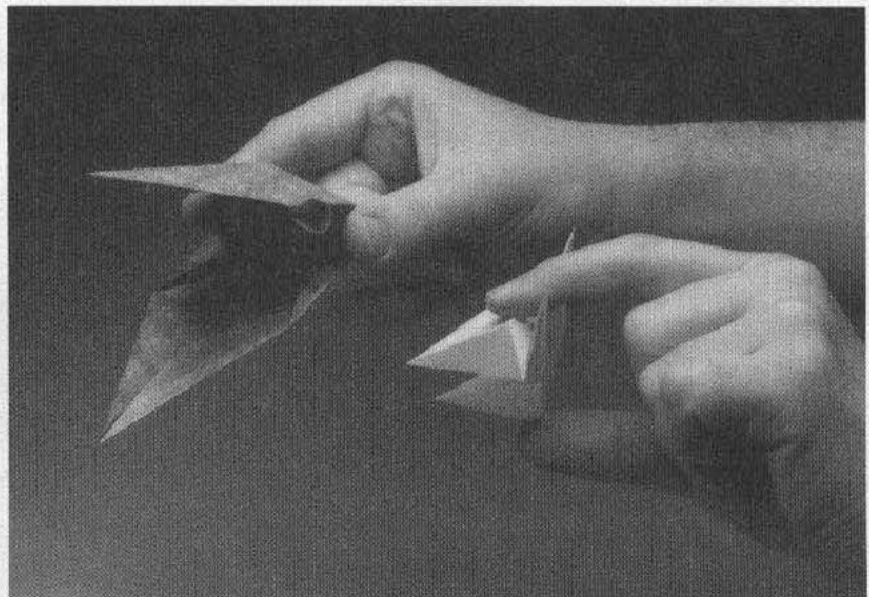

Emu (p.24)



Exhibitionist (p.26)

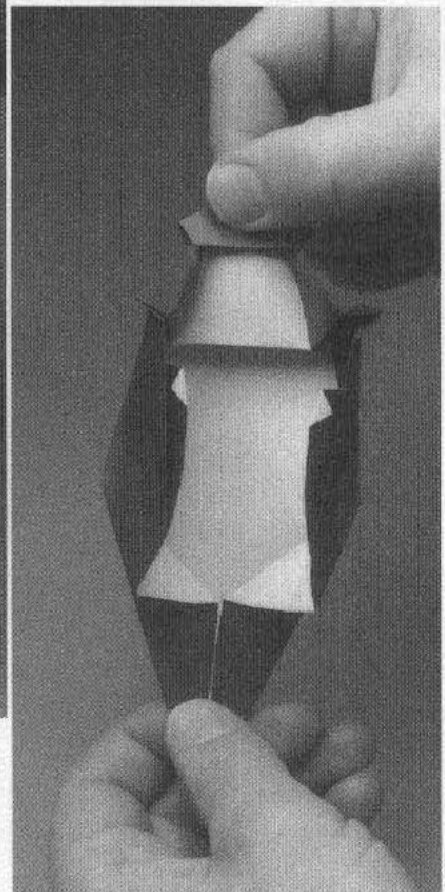

Emu

This subject is the puppet made famous by the New Zealand entertainer, Rod Hull. He uses his hand to form the face of the bird which frequently attacks and humiliates those people whom it dislikes. Although resembling a ventriloquist's dummy, Emu never talks ...

This origami version (call it a Crocodile if you prefer), uses an action mechanism used previously by Randlett, Momotani and Jackson.

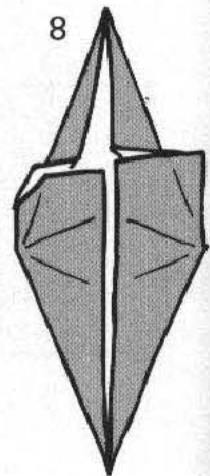
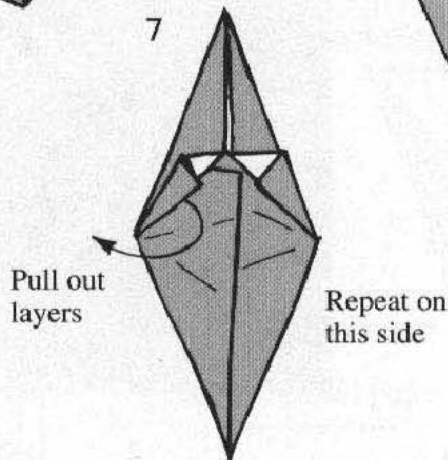
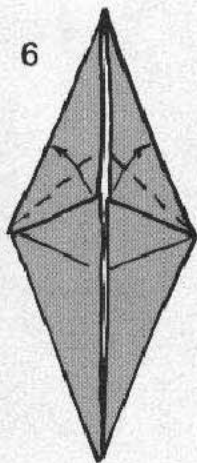
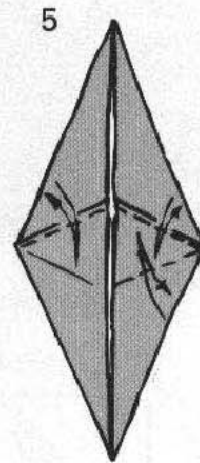
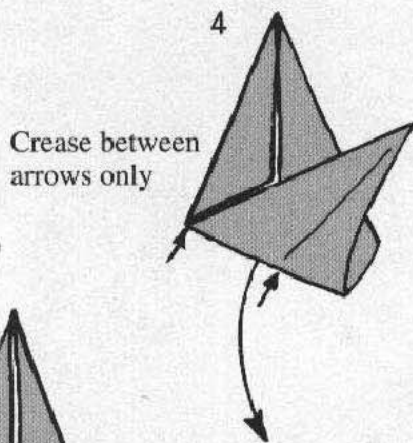
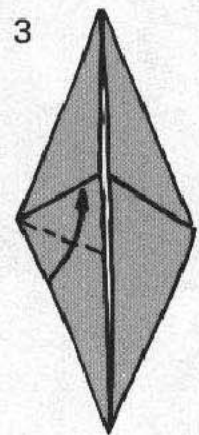
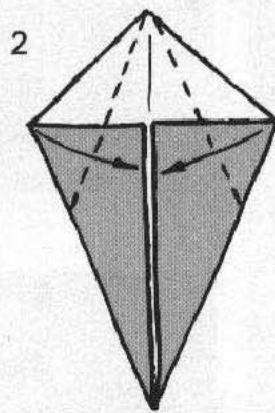
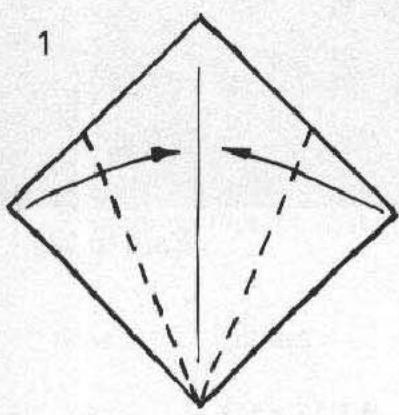

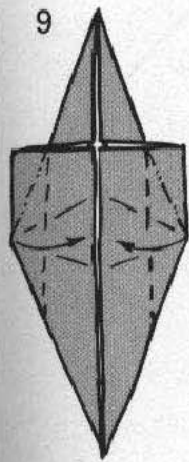

9

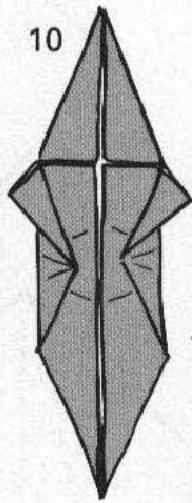

10



Reinforce
existing
creases

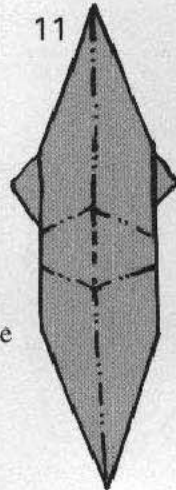

11

11a

11b

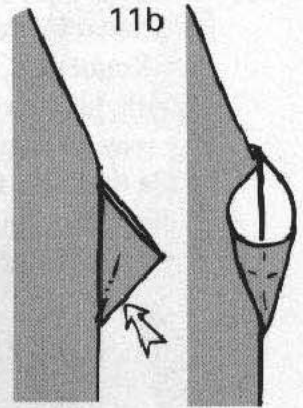

Partially squash eye
flap to make circular
opening

12

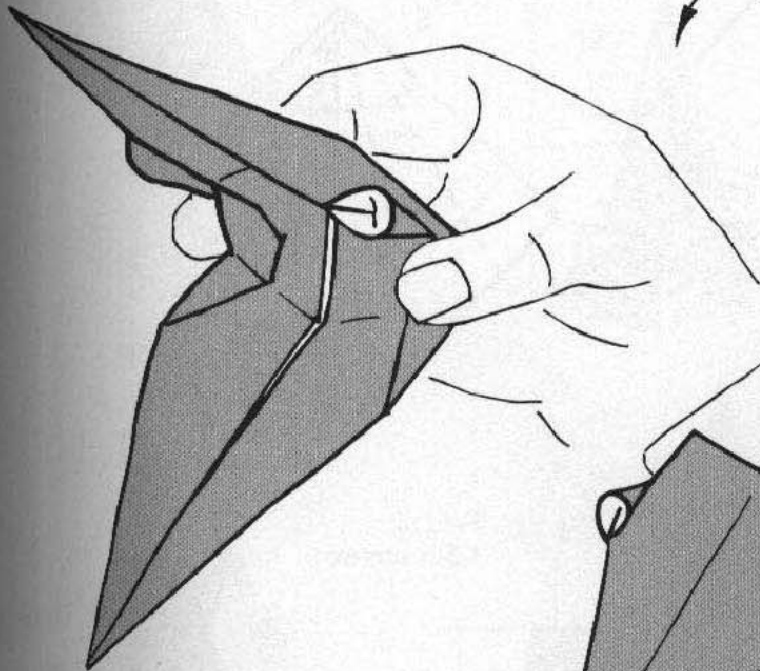

Hold like this,
and squeeze to make Emu
flex his jaws!

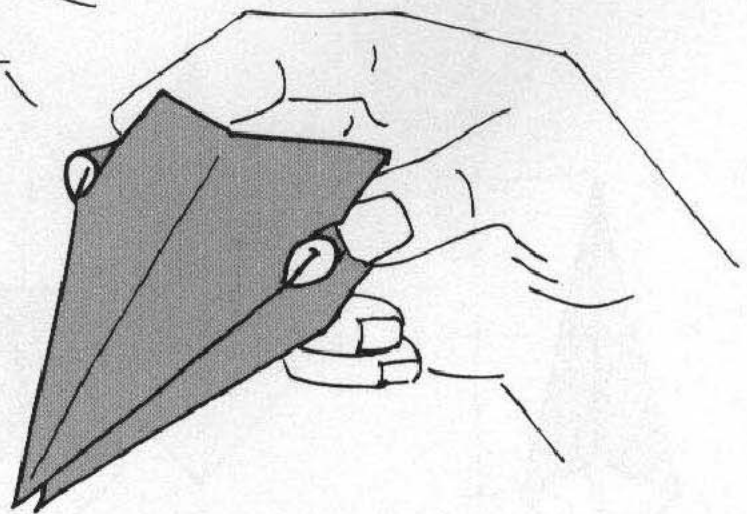

Exhibitionist

Also known as a "Flasher", this design was influenced by the human figure designs of Eric Kenneway. The action is not so smooth, and may need a little breaking in. You may be tempted to add a message inside the man, to be revealed when he flashes: "Nothing much to see in here"... or "I just had a flash of inspiration."

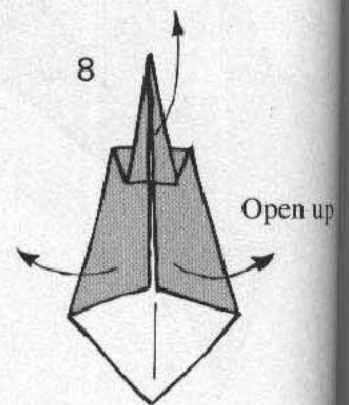
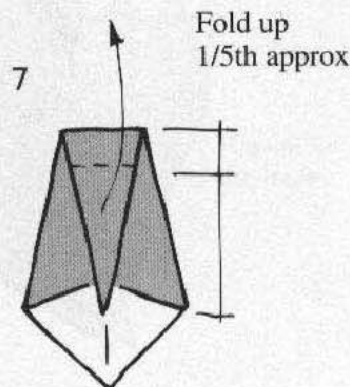
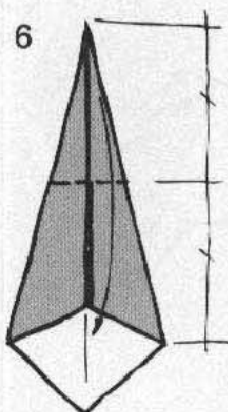
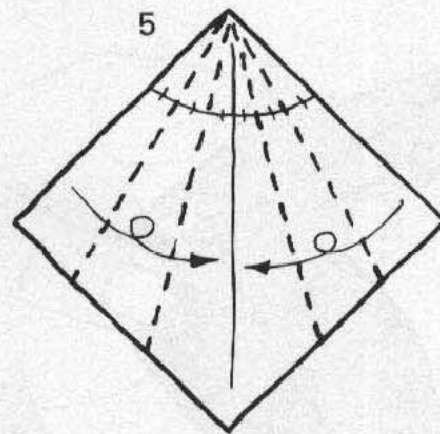
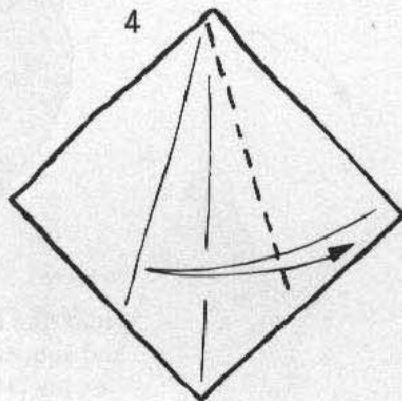
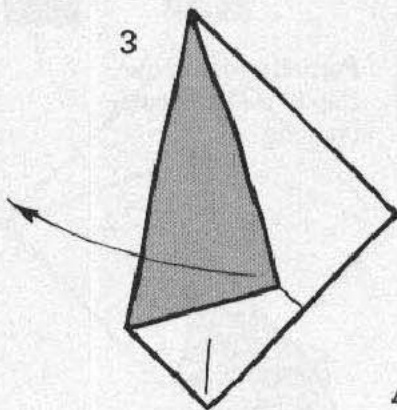
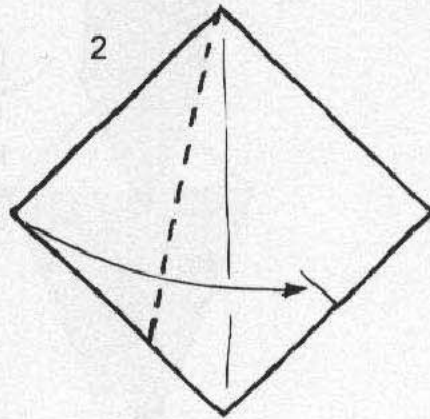
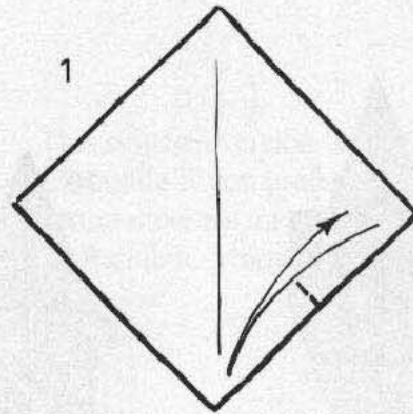

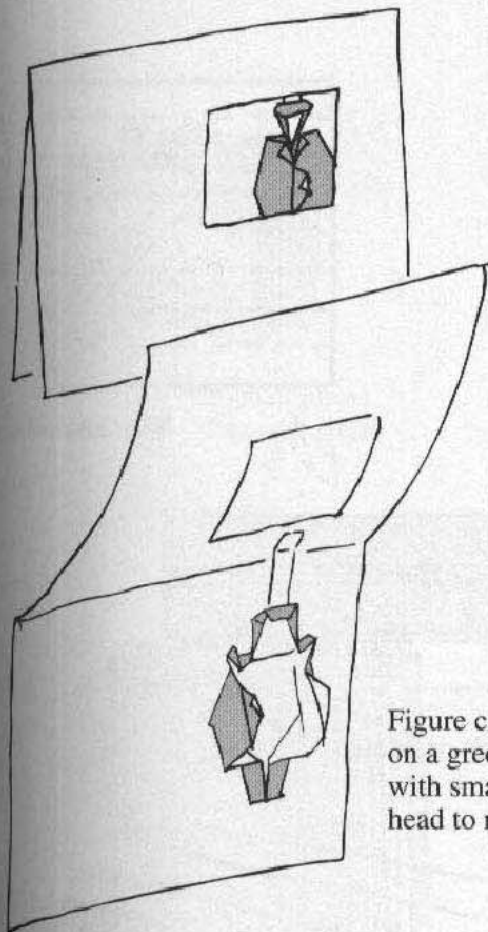
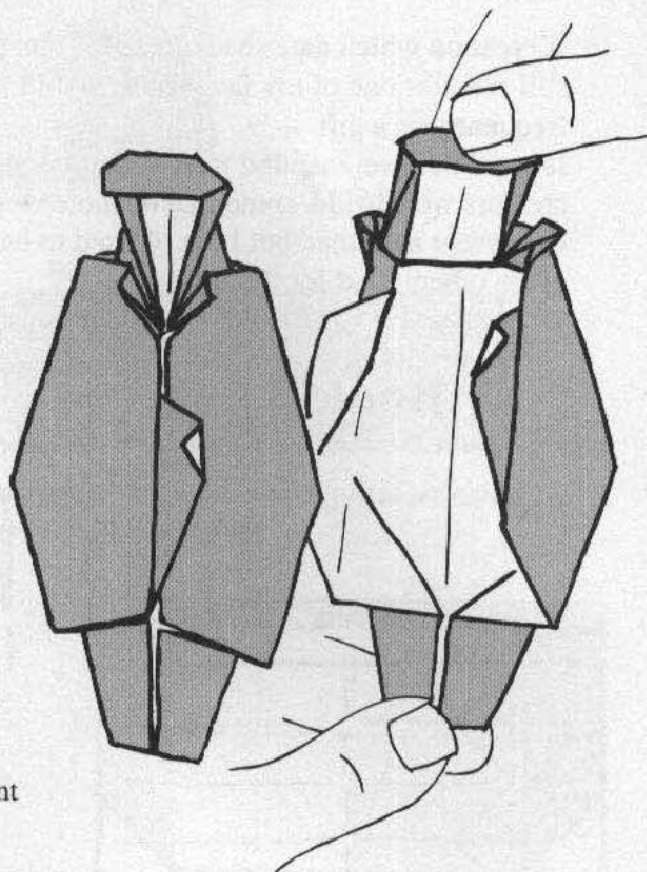
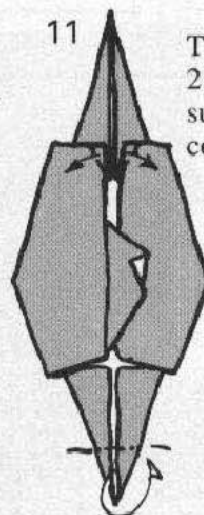
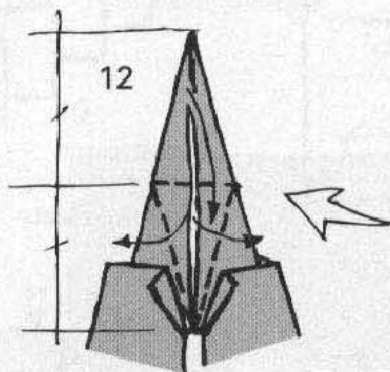
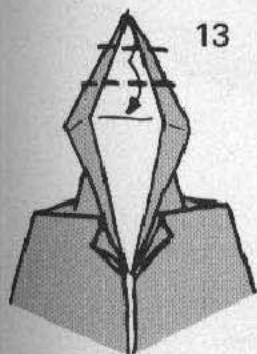

Figure can be mounted on a greetings card with small tab fixed to head to make movement



Hold head and foot; pull gently to make figure "flash"



Turn back 2 corners to suggest a coat collar

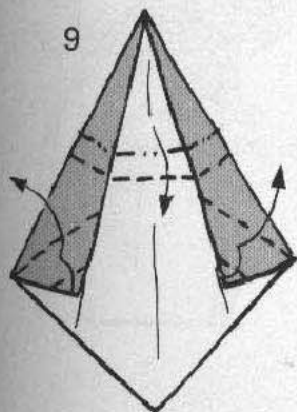
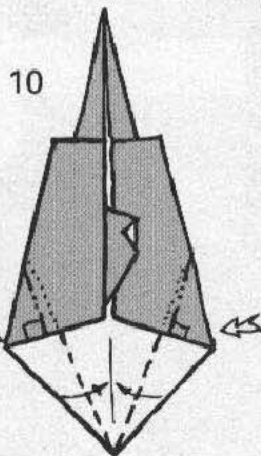

A creation which dates back to 1975, this book still remains one of my favourites, and I fold it frequently as a gift.

It has, I believe, inspired many other books by creators worldwide, some maybe more elegant in concept than this, but I am pleased to have given others food for thought.

Book

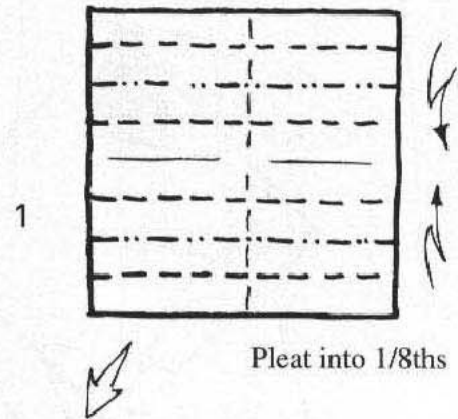

Pleat into 1/8ths

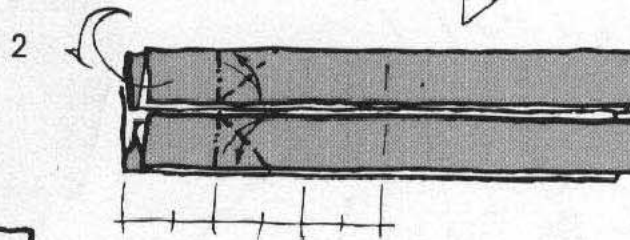

Precrease, then open out

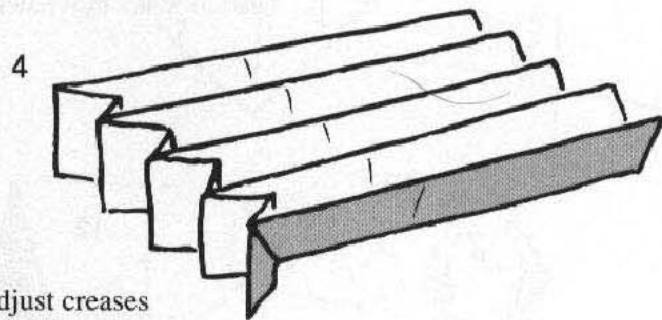

Adjust creases to form pages, and reform pleats

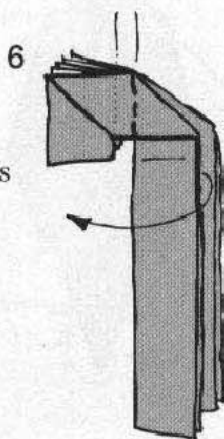
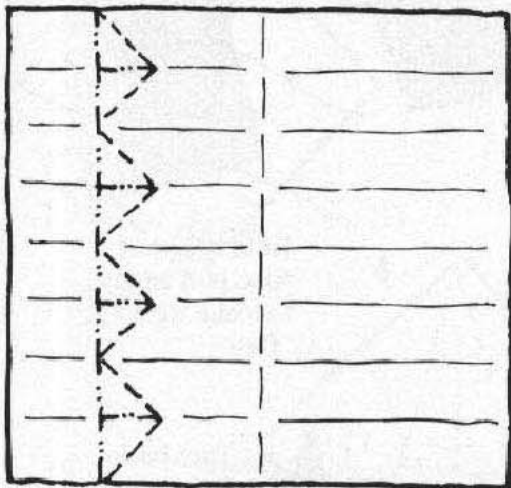

Note gap:
bottom of pages
lines up with
existing crease

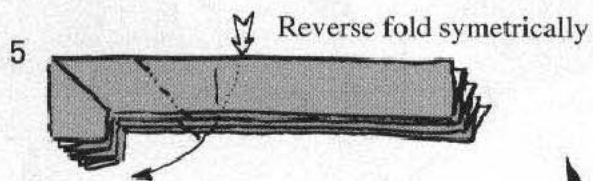

Reverse fold symmetrically

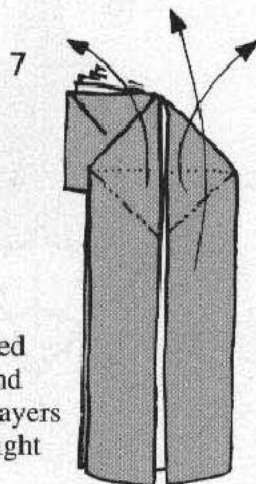

Lift pleated
section and
open all layers
left and right

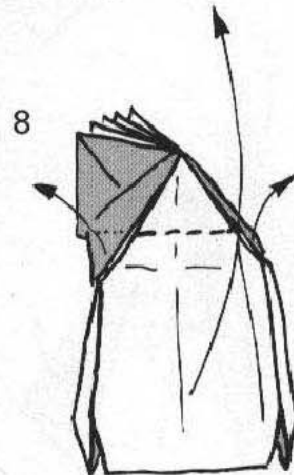

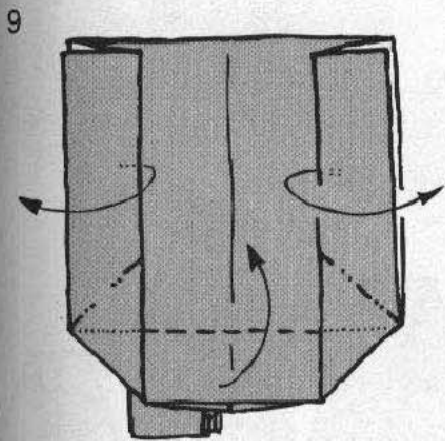
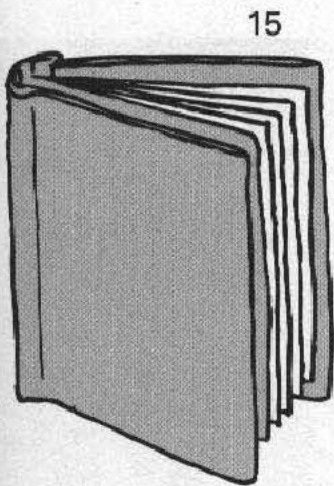
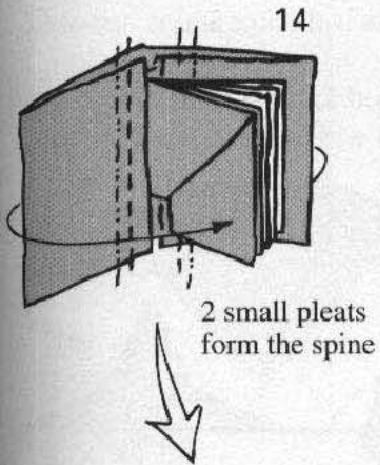

Open layers left and right: swing up pages

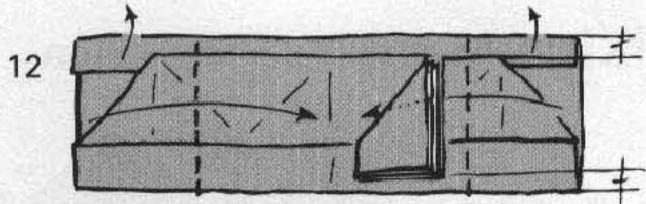
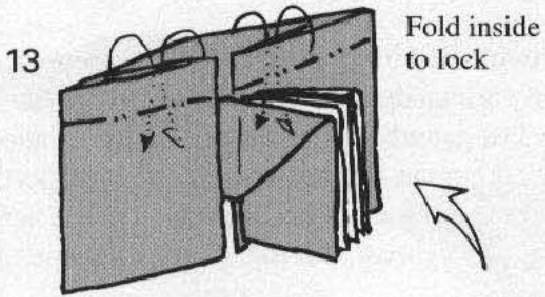

Spaces above and below pages are equal
open up upper edge

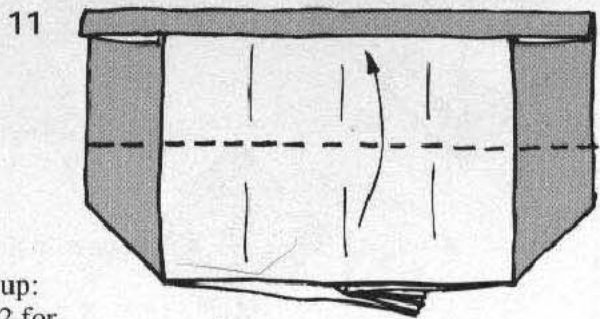

Fold up:
see 12 for
exact position

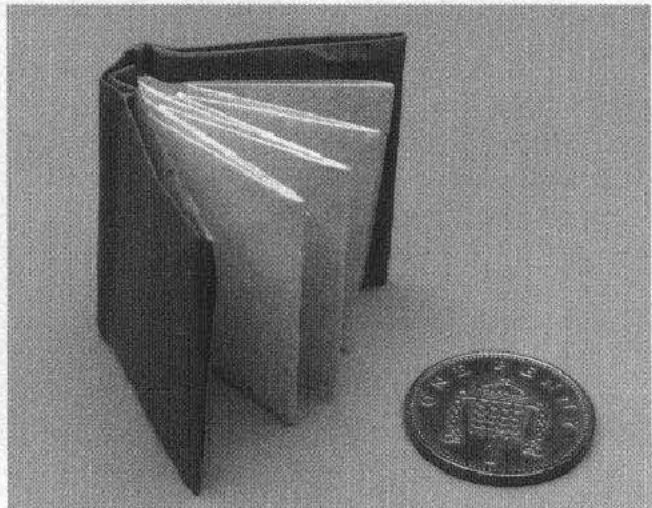
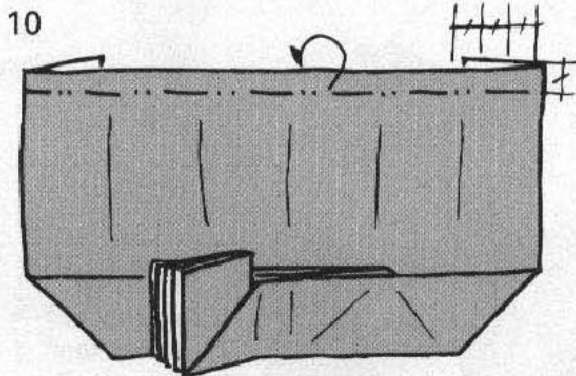

The idea of using two half-bird bases came from Alice Gray in various designs appearing in Robert Harbin's last paperback, *Origami 4*. I had previously tried human figures which were bulky and ill-proportioned. This 2-piece idea may raise a purist's eyebrow, but the

proportion of the figure is good and justifies the liberty. In any case I later made a 1-piece variation, but this is thicker and is less well proportioned.

The action method I found by accident. Try a game of football with a small waterbomb!

Walking Man: 2 piece version

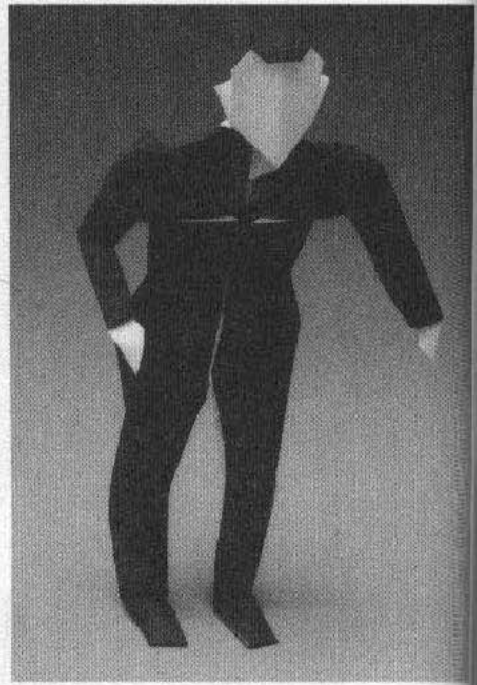
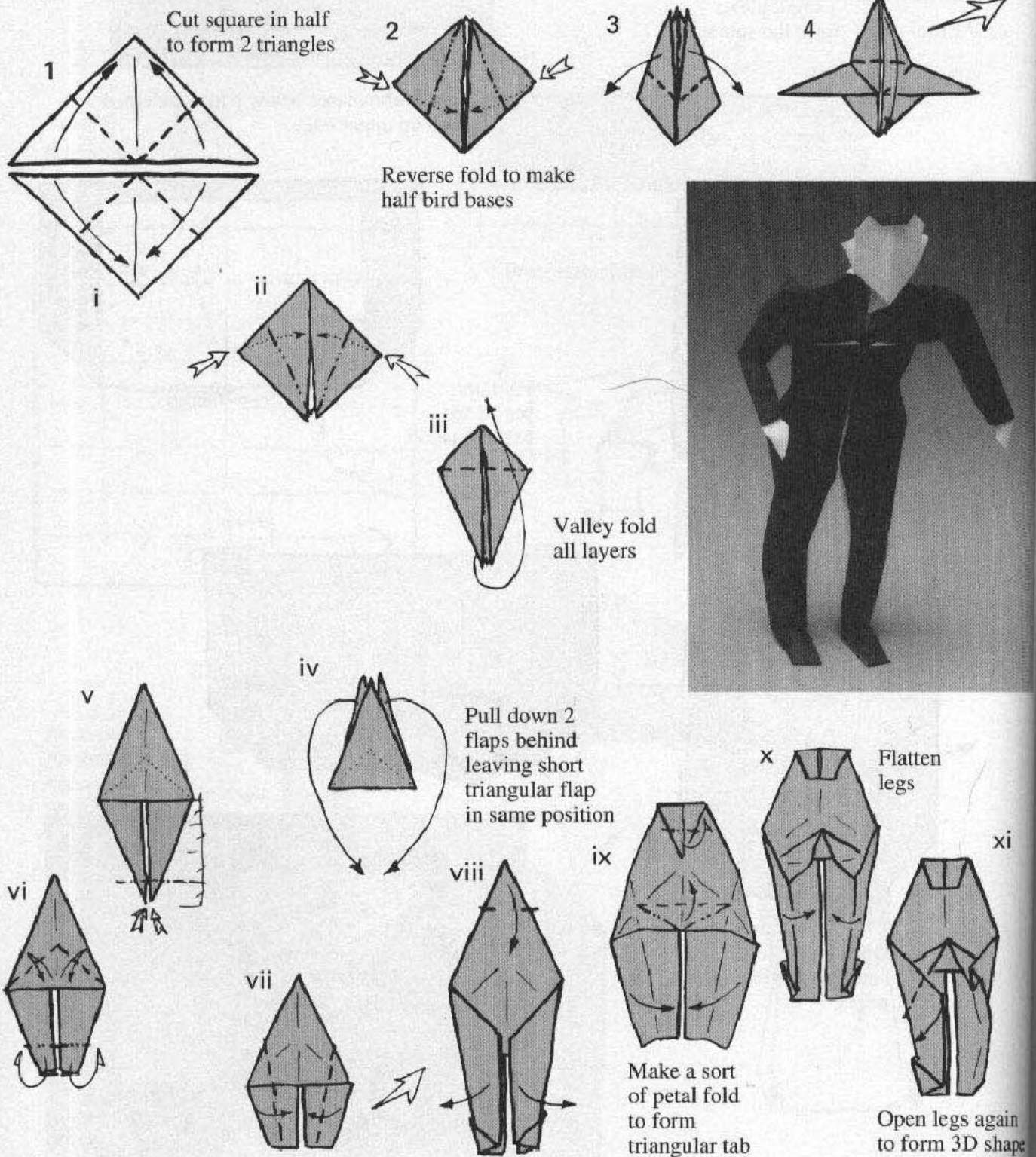

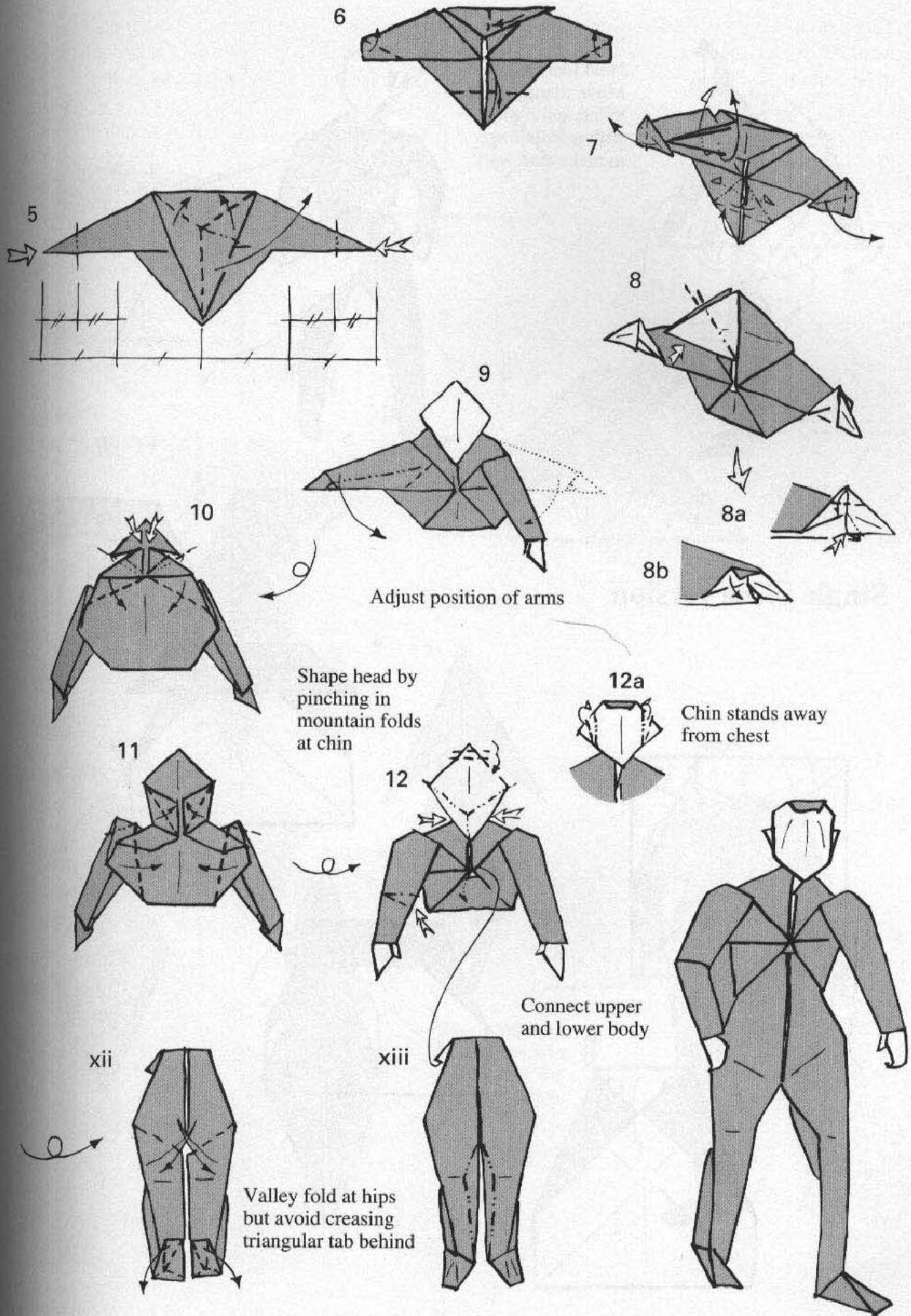

6

7

8

9

10

11

12

12a

xii

xiii

Adjust position of arms

Shape head by pinching in mountain folds at chin

Chin stands away from chest

Connect upper and lower body

Valley fold at hips but avoid creasing triangular tab behind

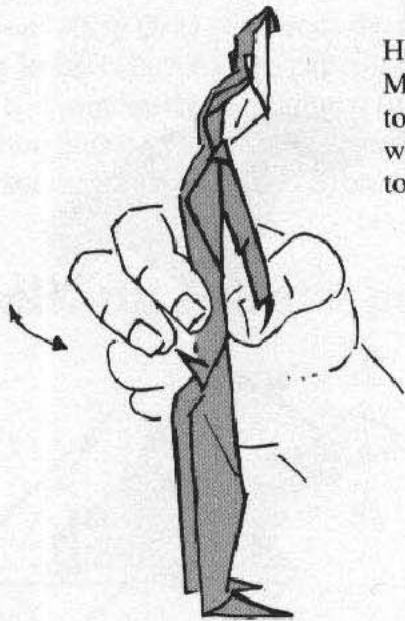

Hold like this:
Move triangular tab
to left and right
with middle finger
to make man walk

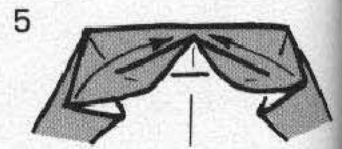

Single piece version

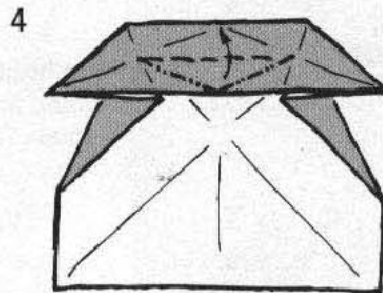
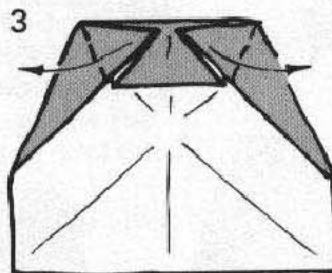
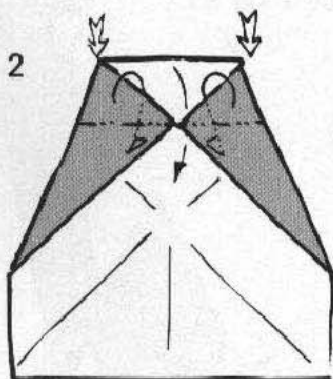
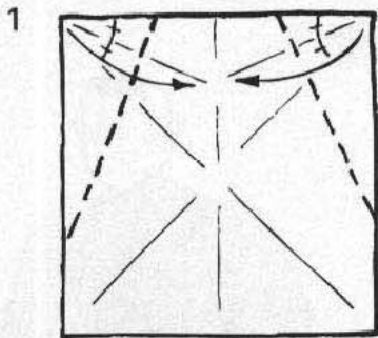

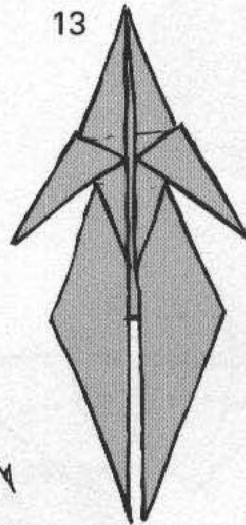
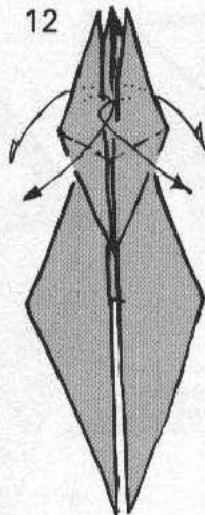
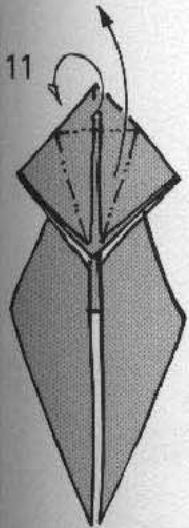
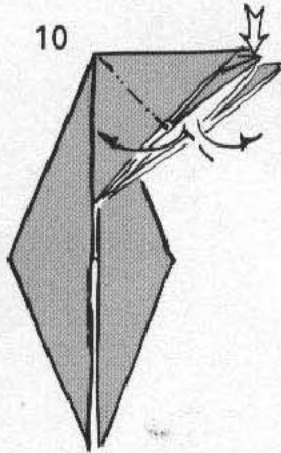
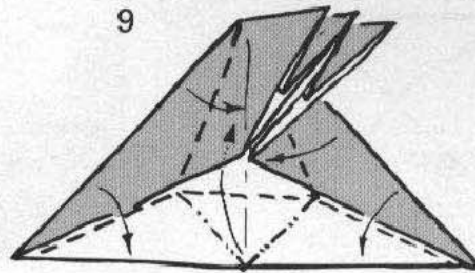
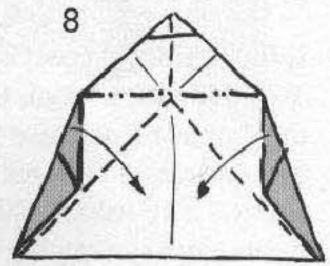
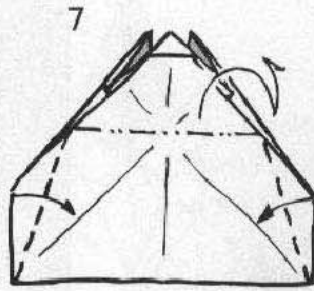
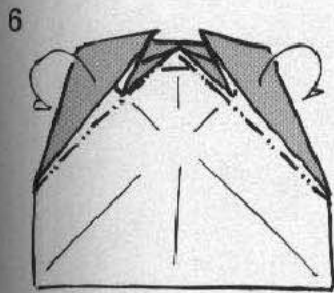

Base complete:
finish legs, arms
and head as for
2 piece version

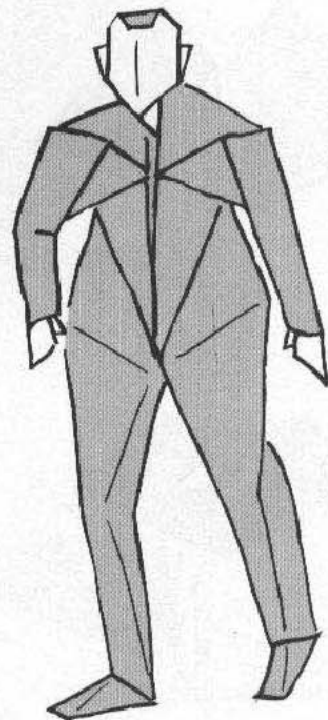

Spectacles

Influenced by a spectacles design of Yoshihide Momotani, this design was created to complete a disguise theme I wanted for a demonstration. The rectangle needs to be about 8 x 16 inches (40 x 20 cms) to be wearable. Try drawing eyes on the lenses.

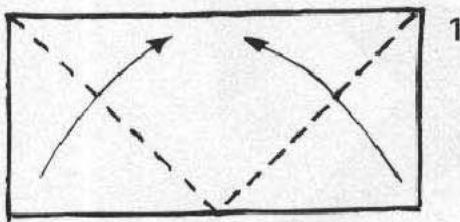
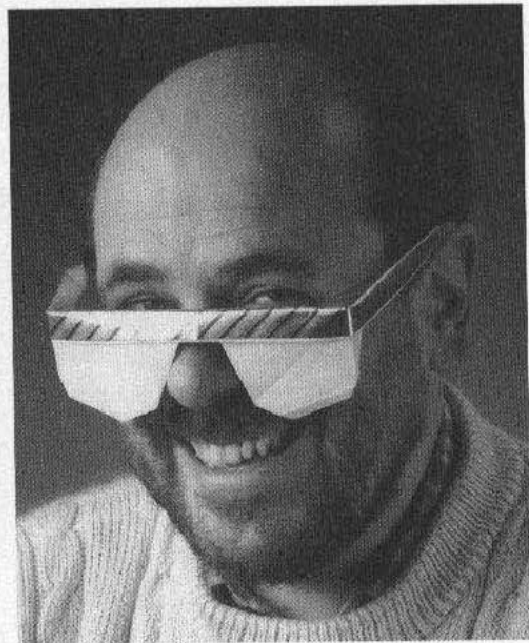

2x1 rectangle

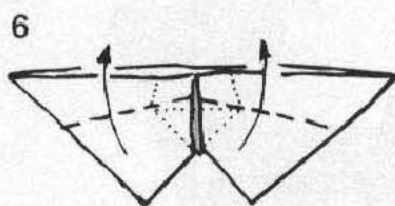
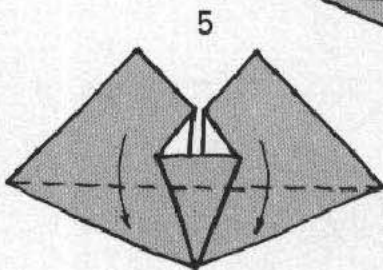
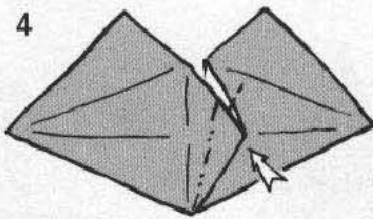
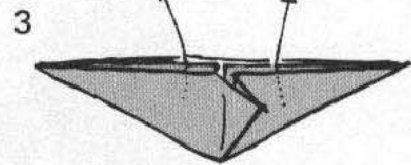
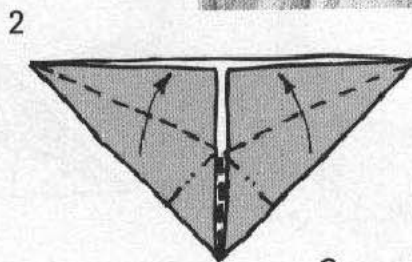

Note position of interior layers (dotted line)

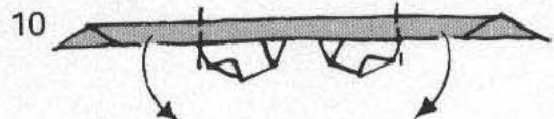
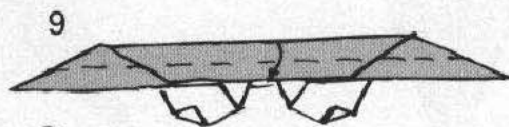
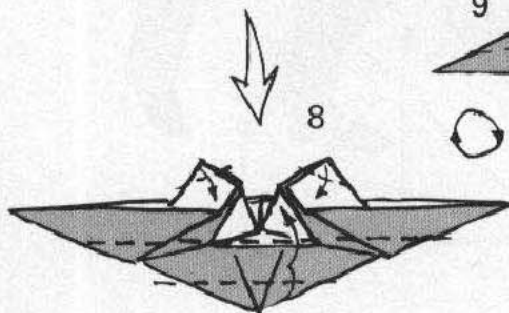
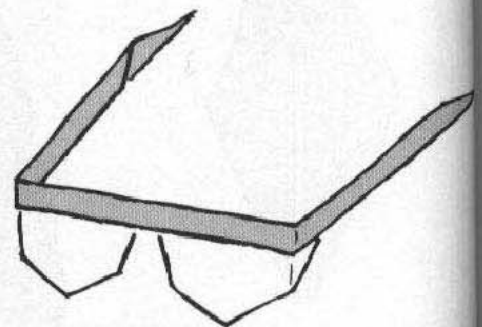
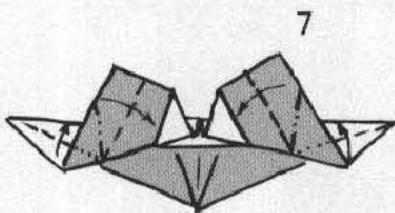

Talking Fox

A design which emerged from a doodle. The basic fold in step 7 is a stimulating shape to me, and I first saw it effectively used by Czech folder, Ivo Zuber, in a "Snow White and Seven Dwarves" scene. Try using a small thickish square to obtain the necessary snap to the action.

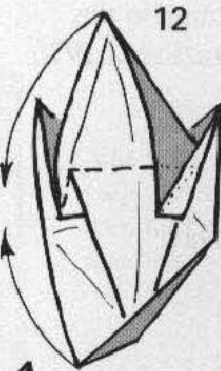
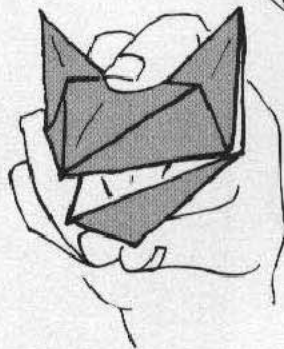
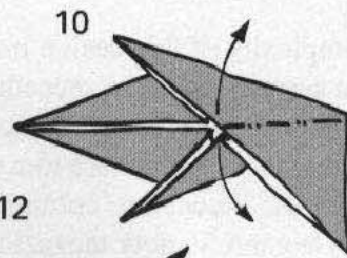
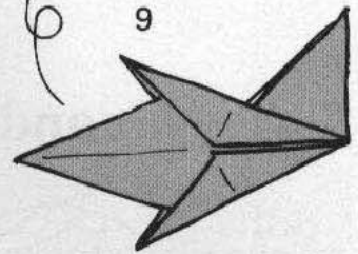
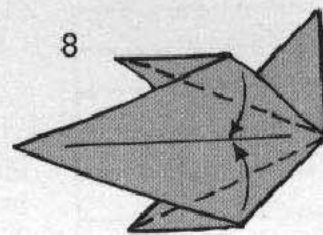
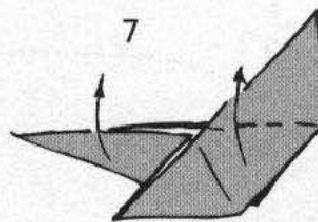
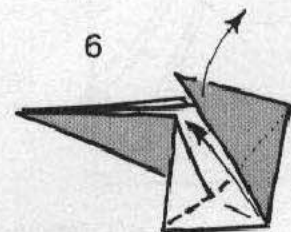
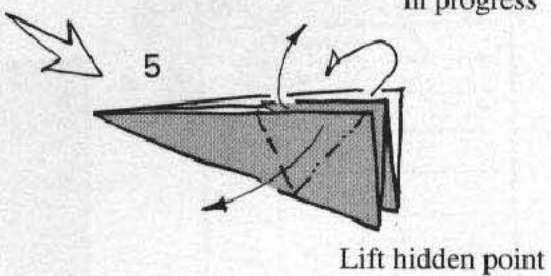
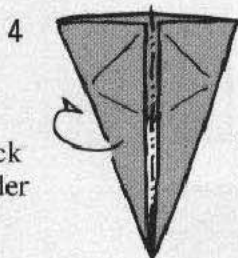
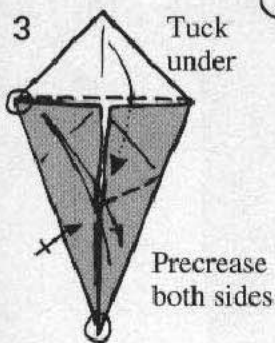
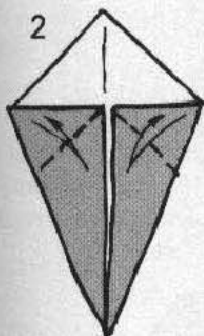
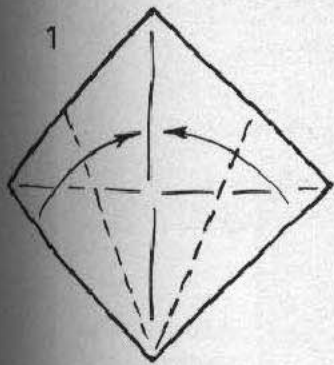

The complexity of this design may come as rather a surprise after the preceding models in this chapter! It was the product of extensive trial and error as a response to a challenge issued by the *Whodunnit* column in the British Origami Society magazine in 1976.

Here a list of then unachieved subjects was published as a stimulus to potential creators. Although you may be tempted to use foil, I don't recommend it: try instead a stiffish conventional paper such as crisp brown wrapping paper.

Nut and Bolt

Bolt

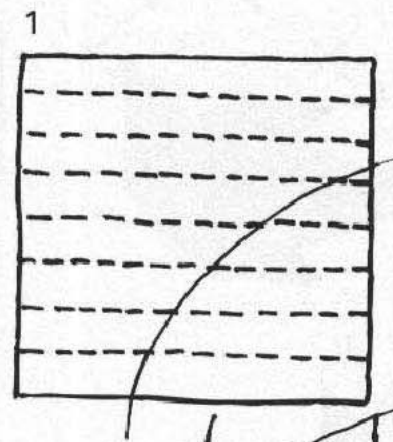

divide into 1/8ths

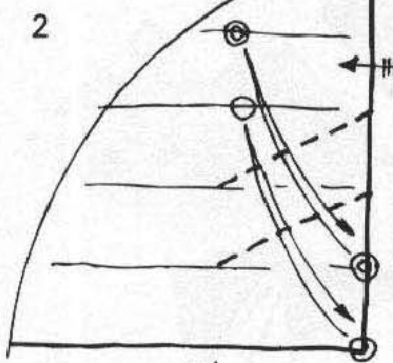

crease between horizontal creases only

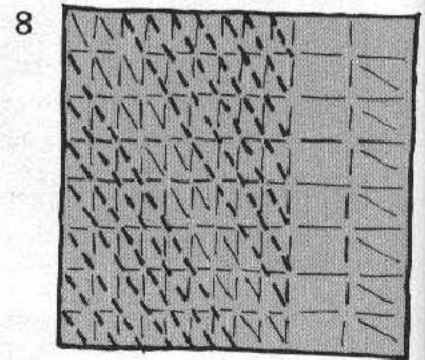
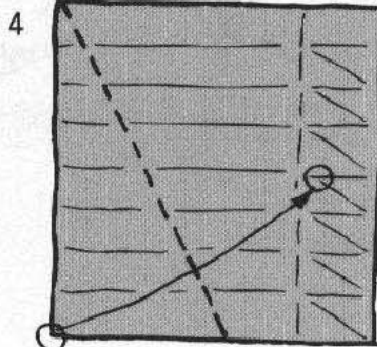
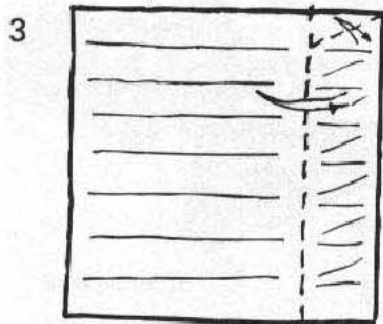

Complete grid with valley folds

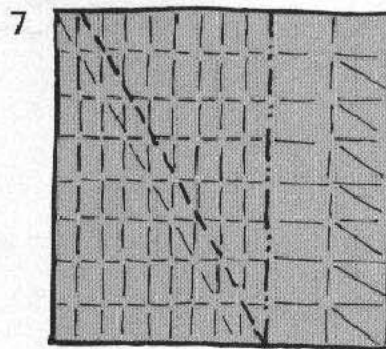

Add one more mountain and valley fold

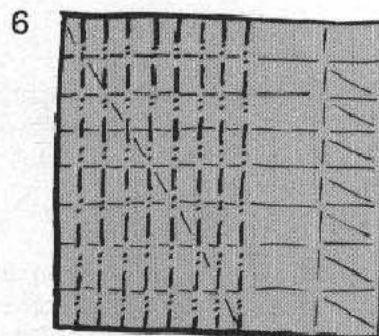

Add mountain folds at intersection of horizontal creases and crease made in step 4

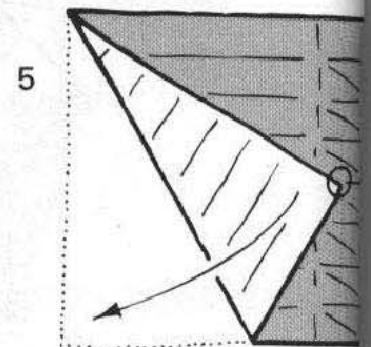

9

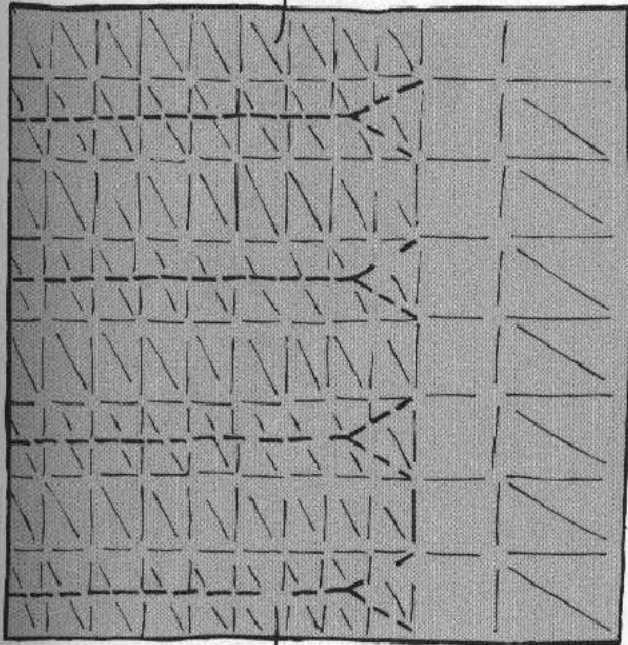

Add Y shaped
valley folds
then form
to a tube

10

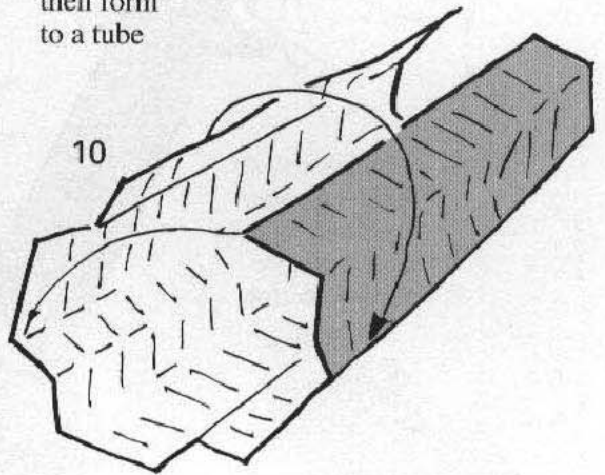

11a

Shows
new folds
required
to collapse
thread

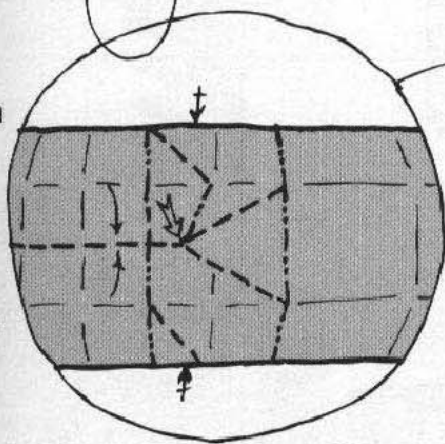

11

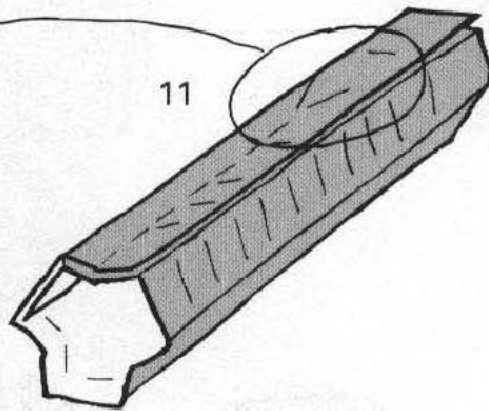

12

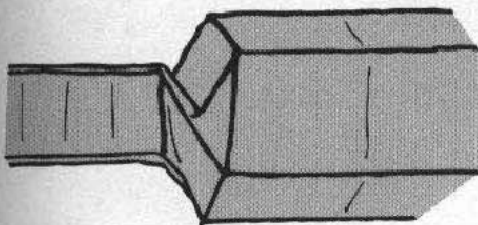

13

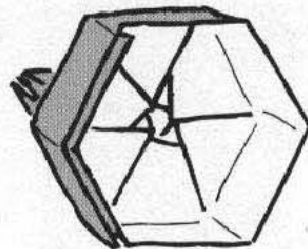

14

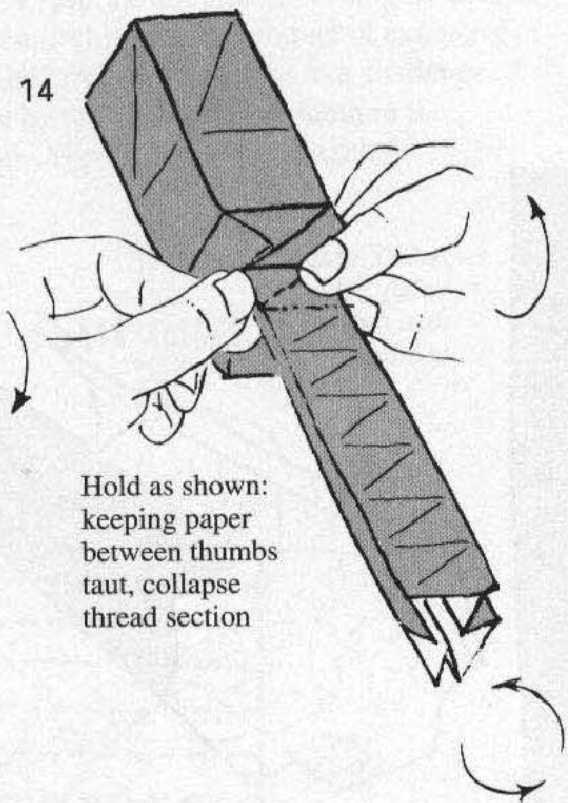

Hold as shown:
keeping paper
between thumbs
taut, collapse
thread section

15

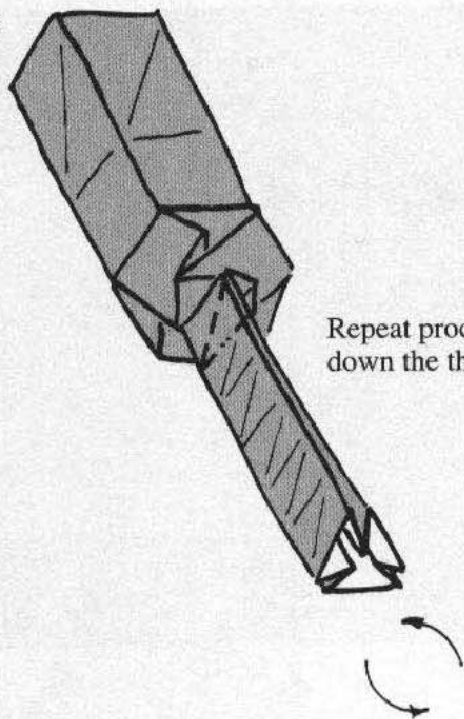

Repeat process
down the thread

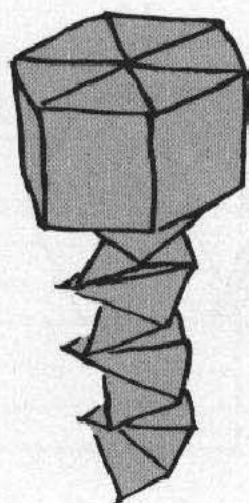

22

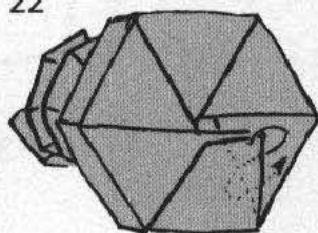

20

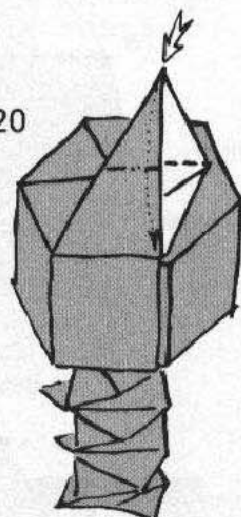

21

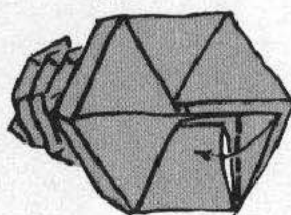

16

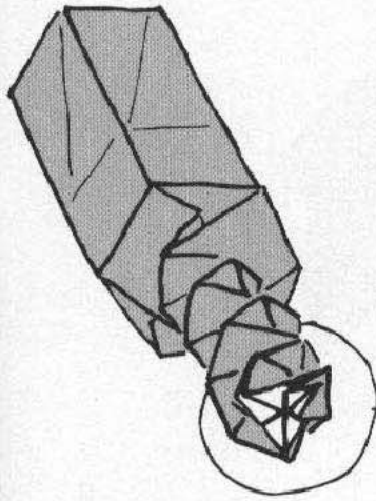

16a

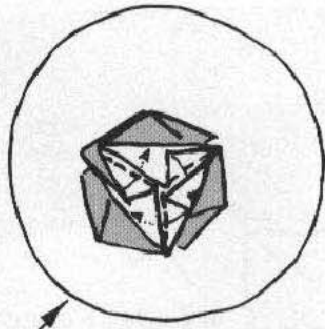

Tuck in corners



19

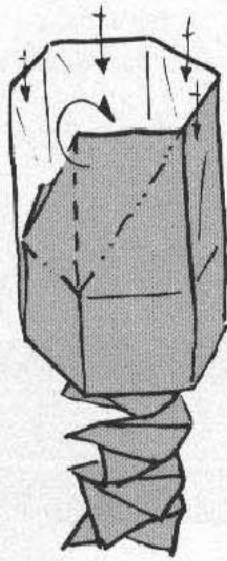

18

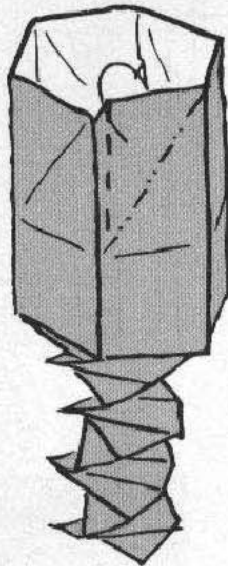

17

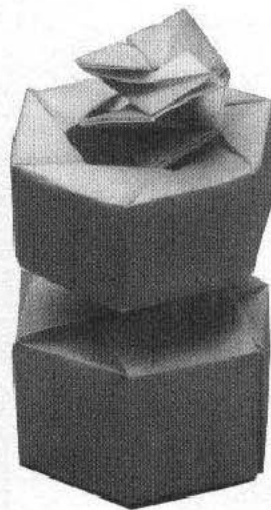
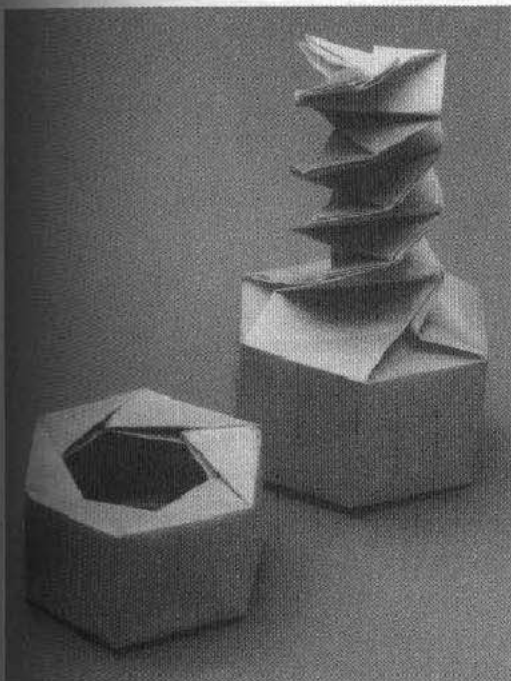
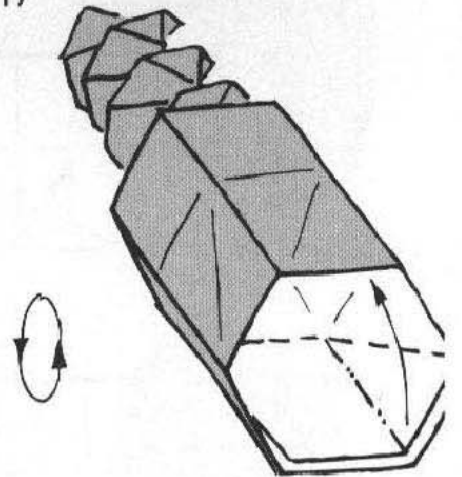

Nut

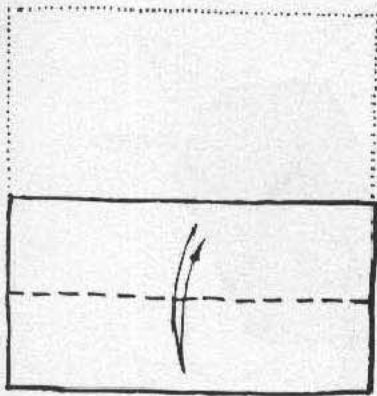

1

use a 2x1 rectangle
one half the size used
for the bolt

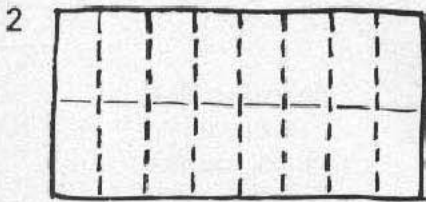

2

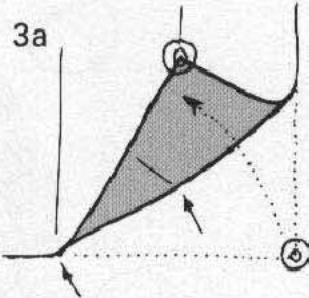

3a

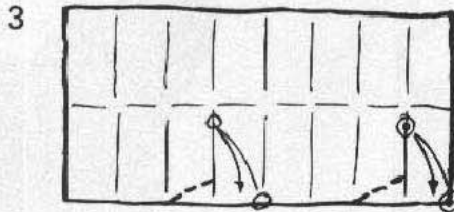

3

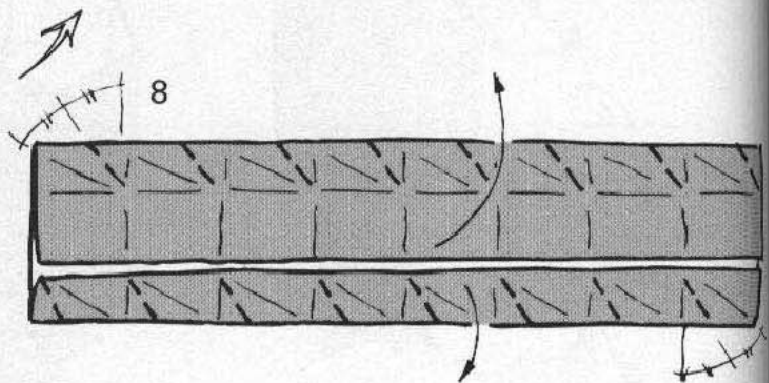

8

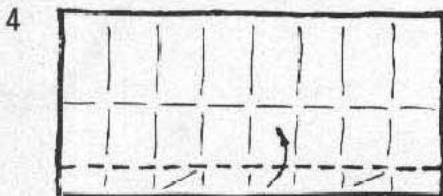

4

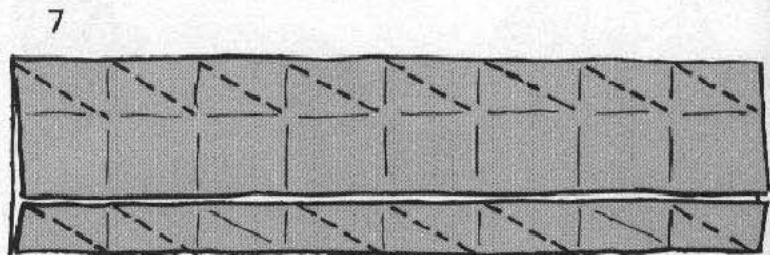

7

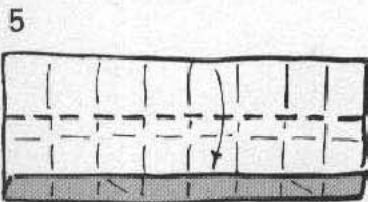

5

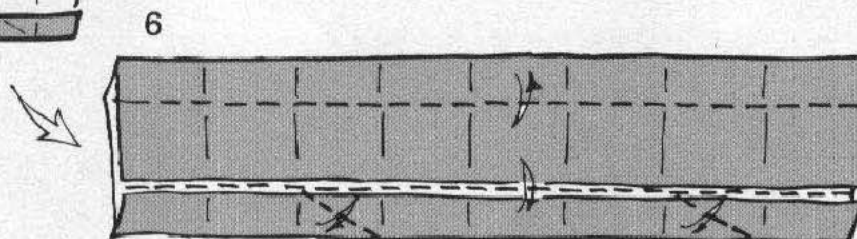

6

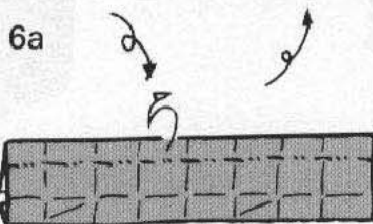

6a

Top valley fold
is marked by the
position of the
crease on the
layer below

(see 6a)

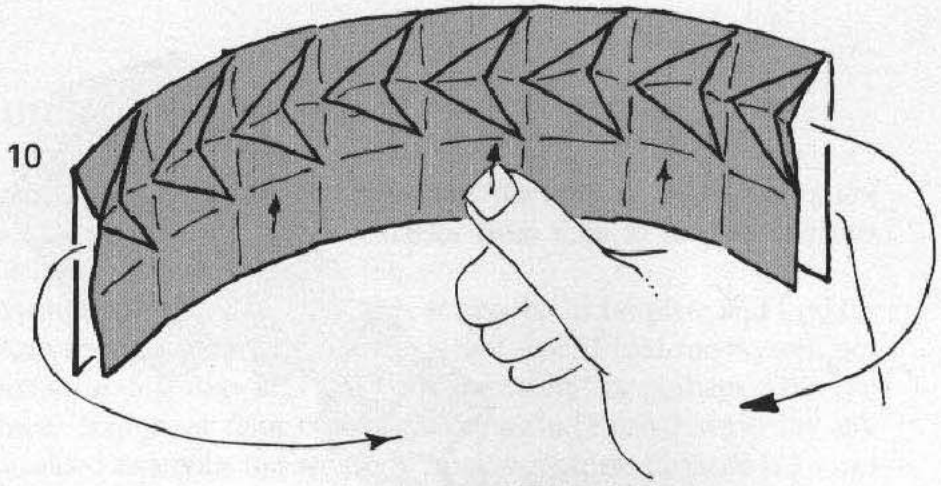

Slide inside layer
allowing arrowheads
to collapse

Precrease 9

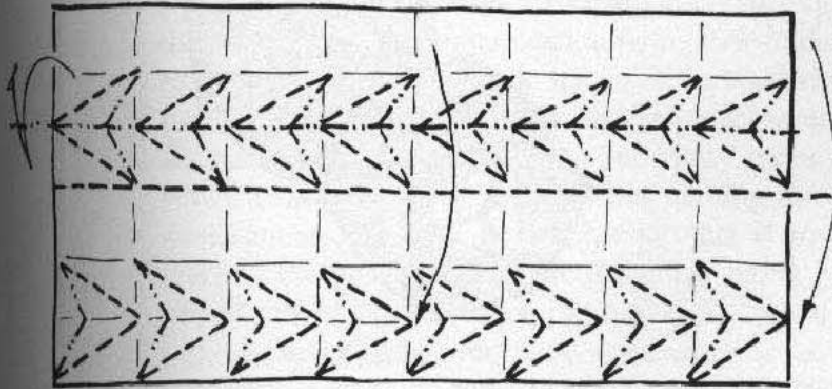

Precrease "arrowhead" shapes thus

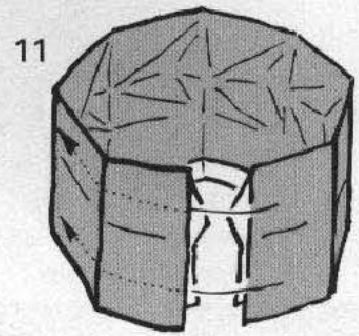

Fold
in half

Interlock 2 sections

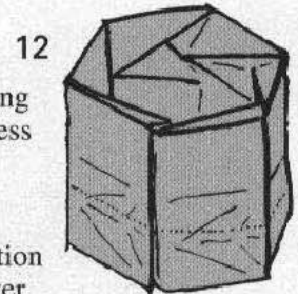
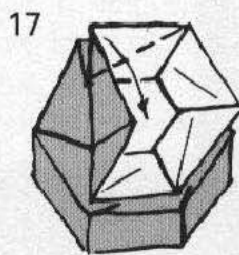
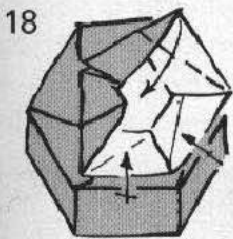

Collapsing
in progress

Dotted line
shows position
of inner layer

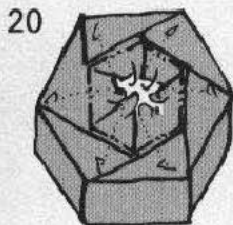

Push layers
into hole
and flatten
inside

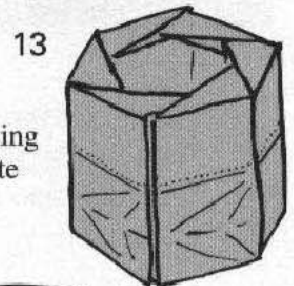
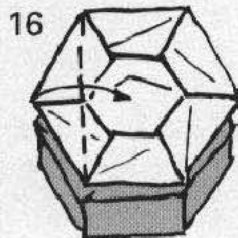

Collapsing
complete

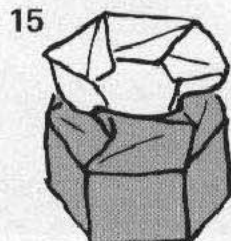
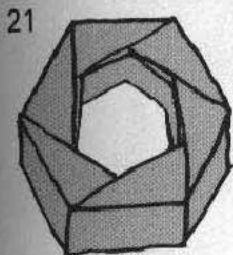

In progress

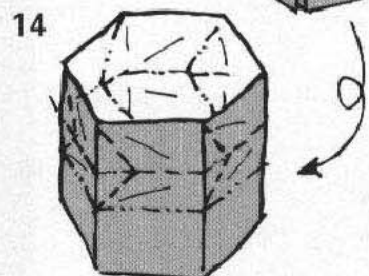

Collapse other end
of nut

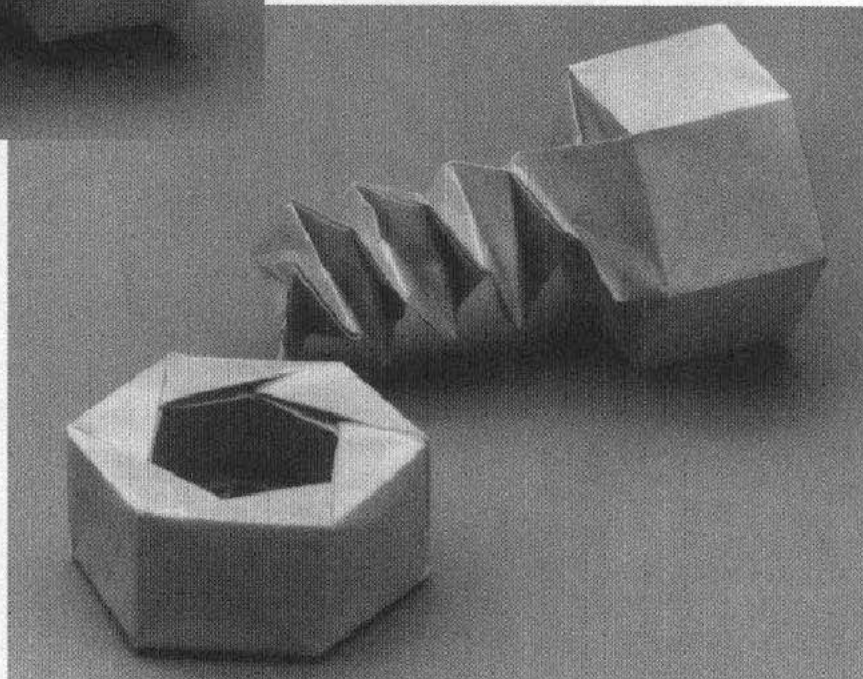
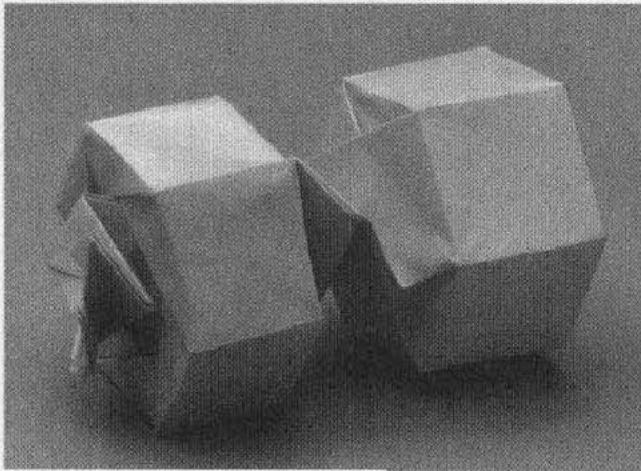
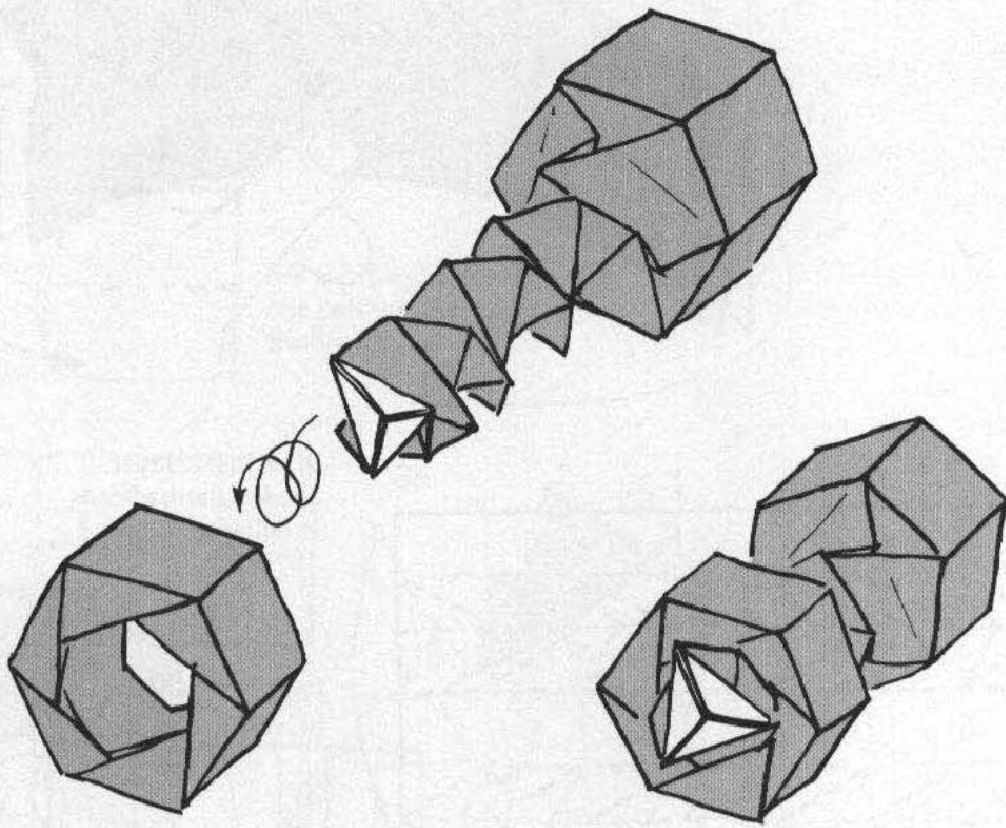

Thoughts on Diagramming

Until the preparation of this book began, I resisted the task of diagramming my work. I have used many rather pompous excuses from time to time to disguise my lack of enthusiasm for this meticulous job...

"Making a drawing fixes a design too much: it may be incomplete and I prefer to be able to return to it and improve it in the future " or "I fold for myself, not others, and I don't think that drawings are really necessary" or perhaps " For me the folding is more important than the diagramming"... "I can always lay my hands on an old folded example and work out how to recreate it, that's if I *want* to recreate it!"

It must be said, however, that there many useful bonuses which do often justify the work. It eases communication with other folders with whom you correspond, to show off your latest work: it's far easier to send a set of diagrams, than a rather fragile model that needs to be securely packaged. Frequently it sorts out an ill-defined folding sequence for you. Many times I have "completed" a design which contains a poor method: but making drawings forces you to get these compromises resolved. Remember too that if your design is good enough, then there is the possibility of the drawings being published in one of the many periodicals of origami organisations in the world today. Finally, your drawings provide a tangible record of your work for the future. Somehow a set of diagrams seem to be a much more permanent statement of your work than the actual finished model itself.

Over the last decade or so, I have been lucky to have had experience of drawing in a more conventional sense, having studied painting portraits and life drawing at evening classes. To improve drawing skills (and they are skills that can be acquired, not inborn in an individual) I recommend that you study at an art class. I have found that this is a fascinating and stimulating activity which helps my origami work: it has encouraged my sense of form and proportion which has in turn emphasized the integrity of my origami subjects. The ability to draw makes you look at the world around you in a quite new and more analytical way.

I have fervently resisted the recent fashion of making drawings by computer, which to me look very cold and lacking in sometimes appealing imperfections. I prefer the simple tools of pencil, pen and drawing board.

Finally, it is most important to give the greatest priority to the drawing of the finished design: it is this that will tempt the reader to fold your work, and therefore this drawing will demand your best efforts! I wish you the best of luck!

Boxes and Containers

There is something irresistible about a small box: it has a completeness and a simplicity of form which makes it an ideal origami subject. Tomoko Fuse has shown us that.

Not all apparently simple boxes in origami have a simple folding method, however, but the challenge of folding a box to a precise format is always intriguing. In this chapter, there are a variety of boxes and containers, some of which are practical, others which are a technical challenge, providing container and contents from a single sheet. The cigarette packet and matchbox could even be described as *trompe l'oeil*, and have been known to trick a smoker into accepting the offer of a smoke....

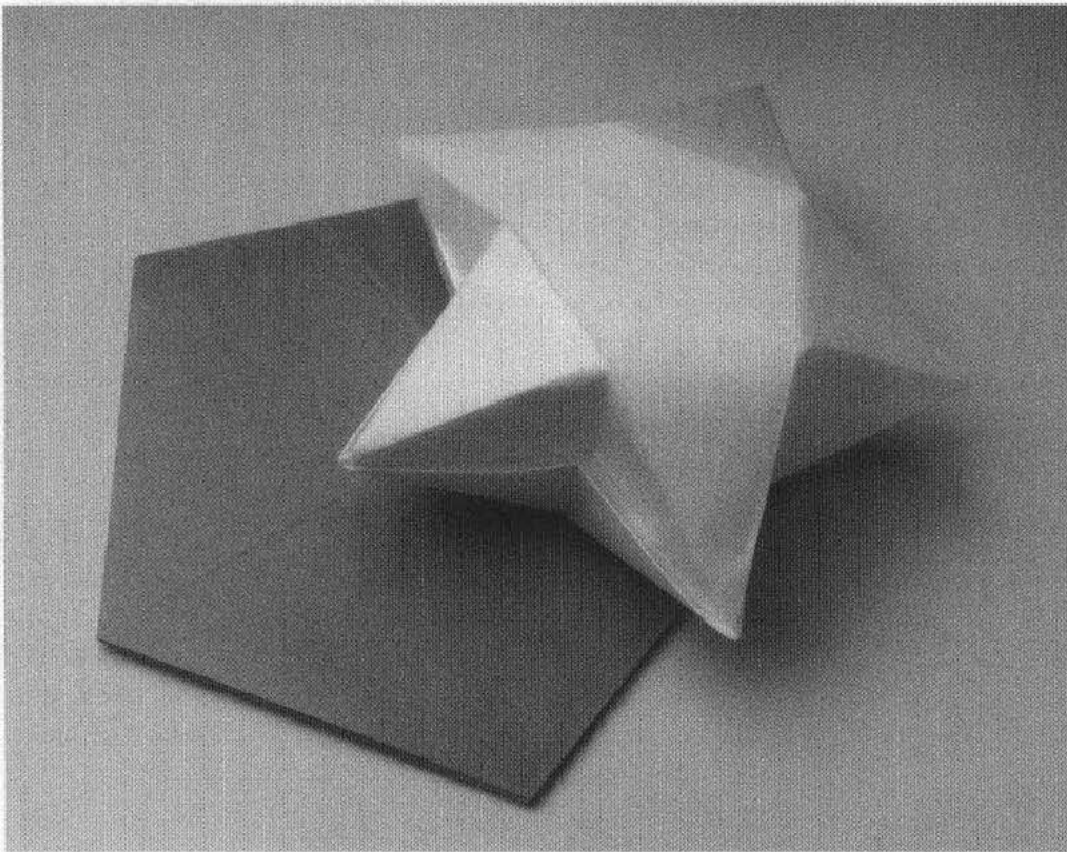

Star Container (p. 46)

This wa
pentagon
It pointe
of the A
to penta

1 U



This was inspired by the simple pentagon created by David Collier. It pointed me towards the exploration of the A-, or Silver-rectangle in relation to pentagonal forms; see p.22.

1 Use A size paper

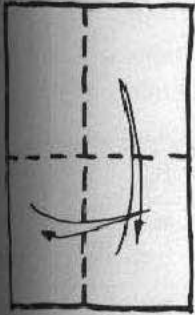

2

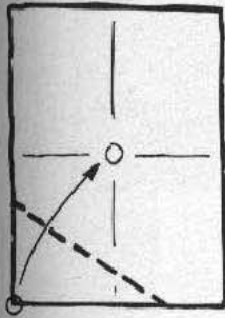

3

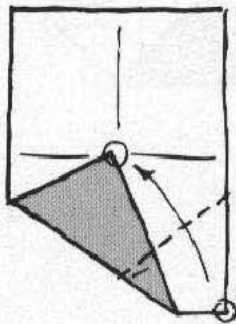

Pentagonal Envelope

4

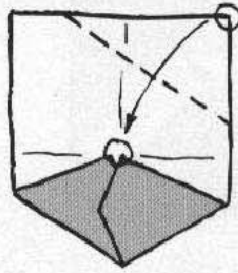

5

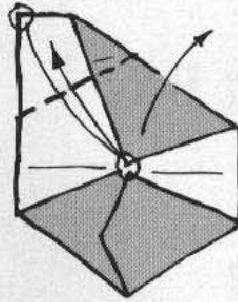

6

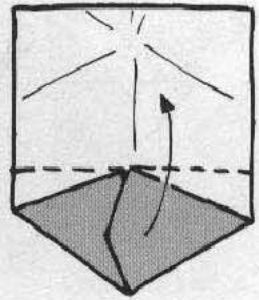

7

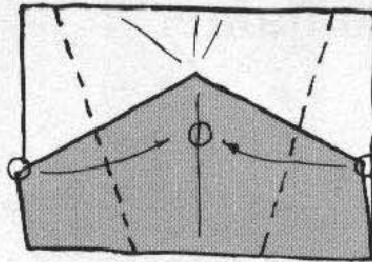

see 8 for positioning

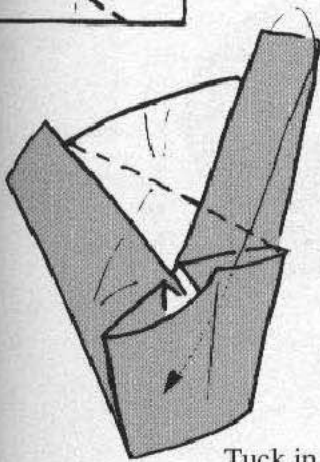

Tuck in

10

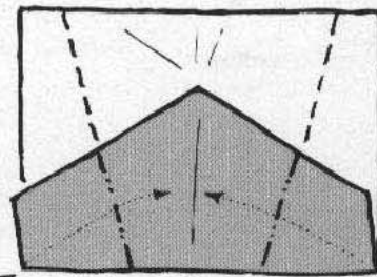

Reverse folds

8

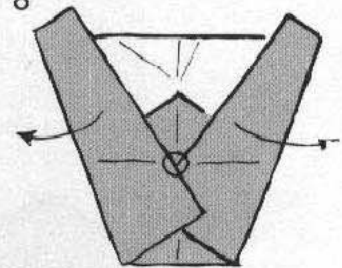

Existing creases are parallel to horizontal lower edge



11

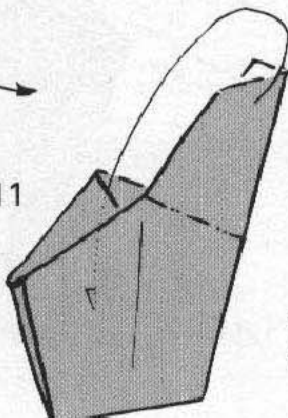

Tuck in to lock

12

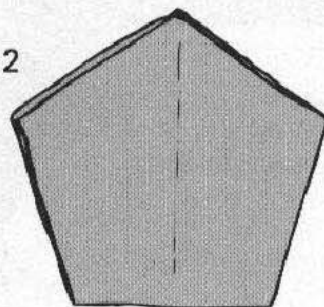

Gift Box

Lid

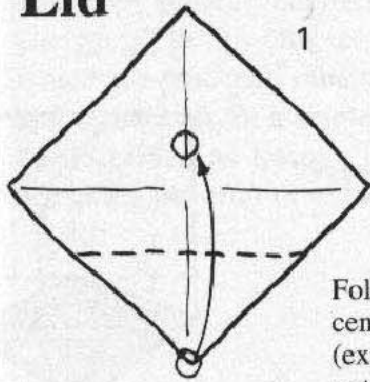

1

Fold past
centre point
(exact position
not important)

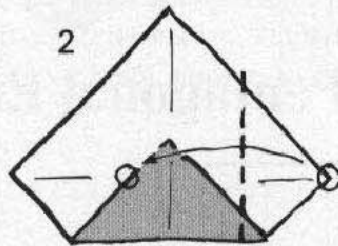

2

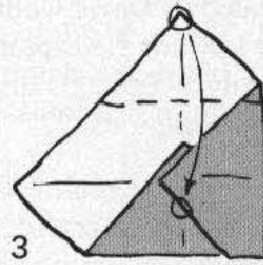

3

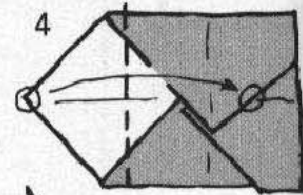

4

5

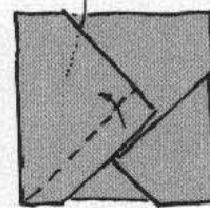

Pull out
previous
corner

Star Container

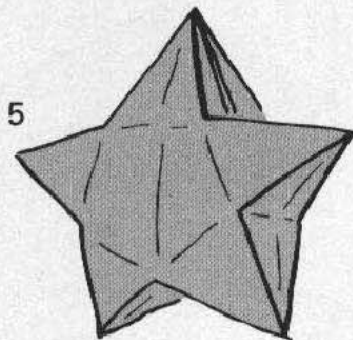

5

Start from Pentagonal envelope

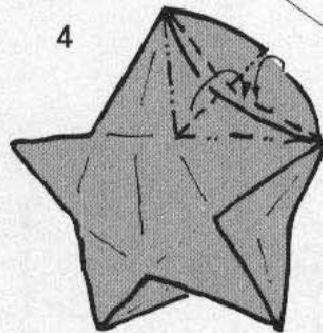

4

Insert gift
then close
here

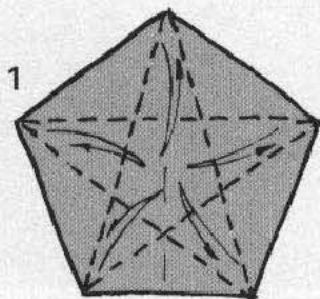

1

Precrease
valley folds
and mountain folds

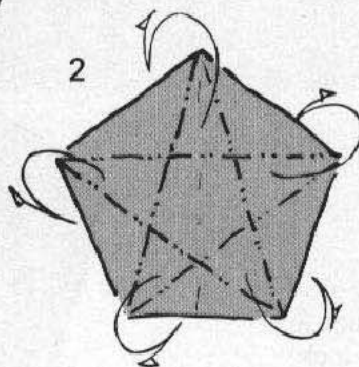

2

3

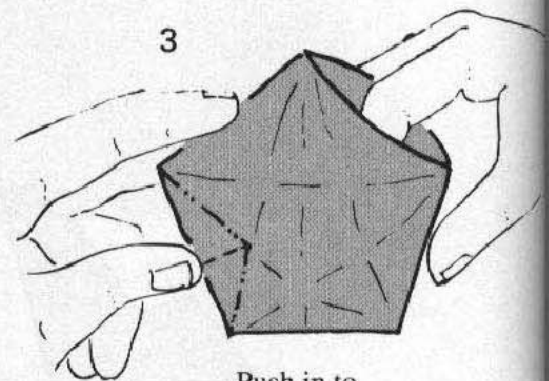

Push in to
give volume -
repeat on each side

This gift box was influenced by a blintz-form box by Akira Yoshizawa: a relation to the traditional masu but with locked corners. Unlike the excellent modular boxes of Tomoko Fuse, the lid and box have no direct size relationship, and it's necessary to make the box a little smaller than the lid. Only trial and error will make the results fully satisfactory, so try again if your first attempt was unsuccessful.

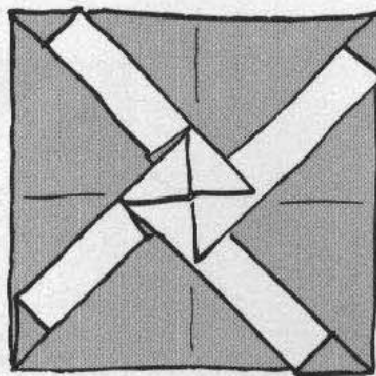

14

13

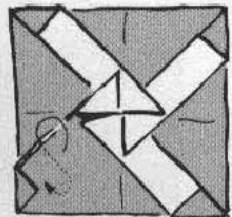

12

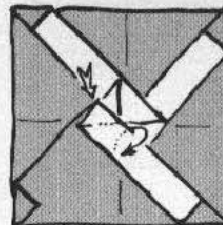

Tuck final edge underneath to make symmetrical

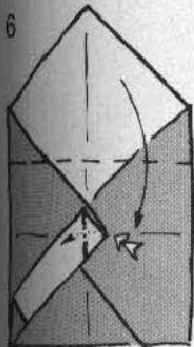

Reverse fold corner at centre

11

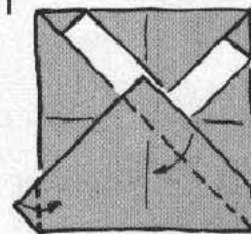

7



Repeat process in 5+6 clockwise around square

10

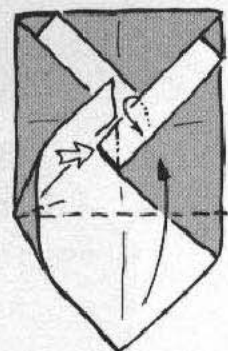

8

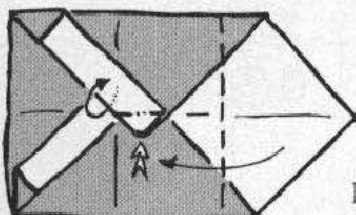

9

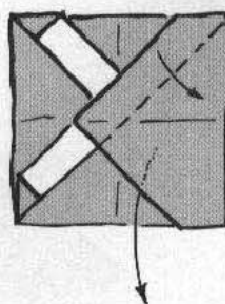

Pull out corner reverse folded in 6

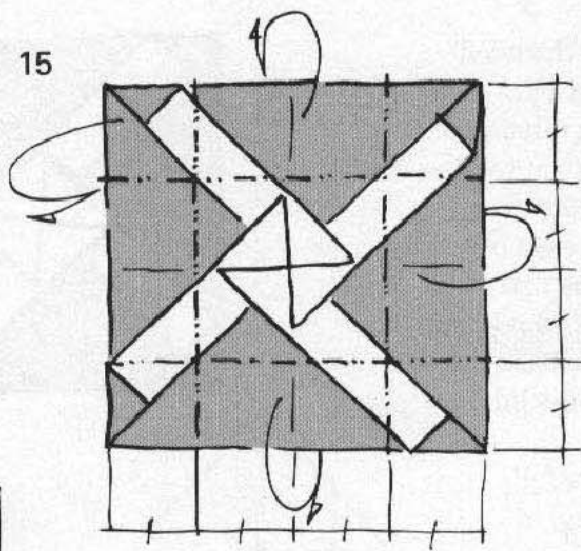

16

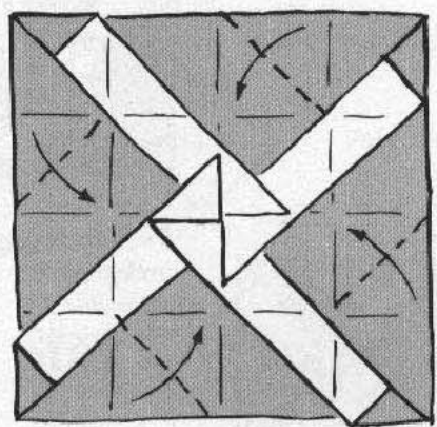

17

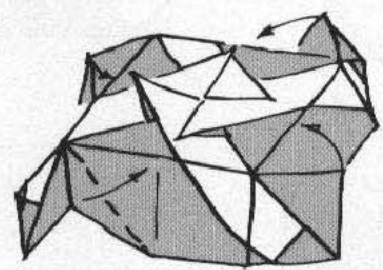

Form box shape

19

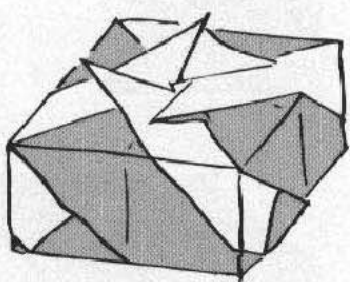

18

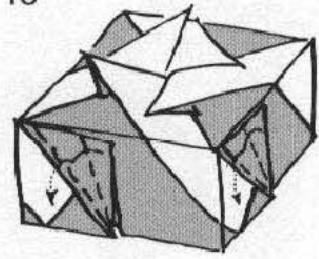

Valley fold twice and tuck in

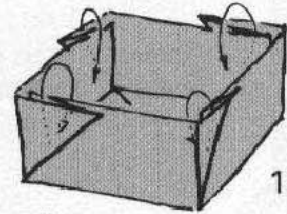

12

Tuck under "blintz" edges to lock

14

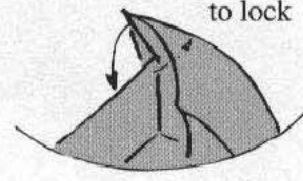
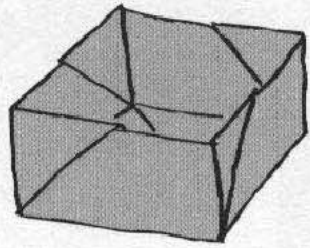

13

11

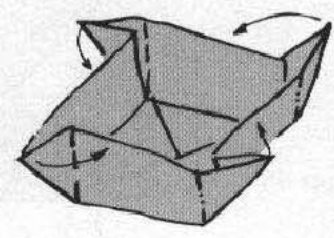

Size and proportions of box and lid can be varied by positions of creases in Lid 1 + 15 and Box 9

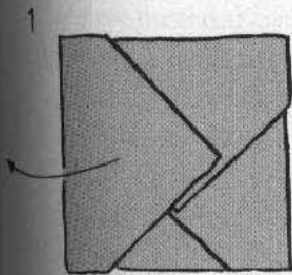

Start from 5 of lid

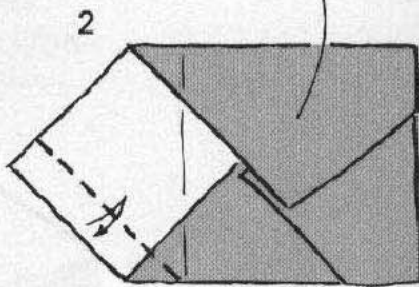

Precrease

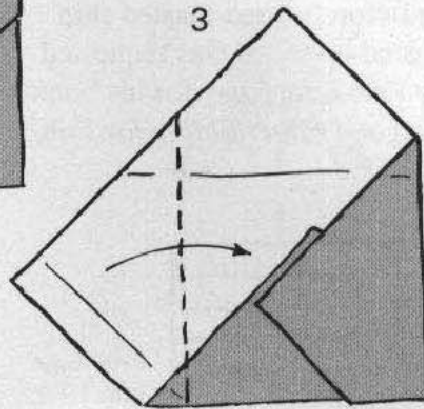

Box

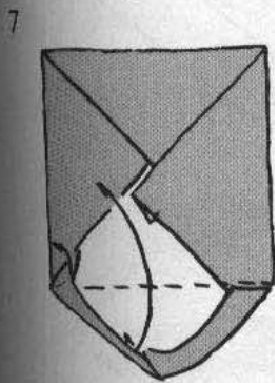

Repeat clockwise

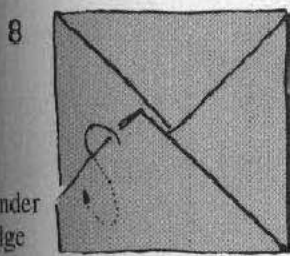
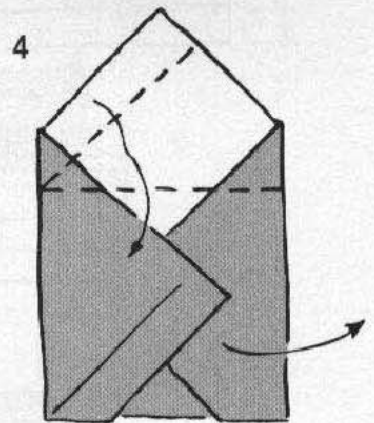
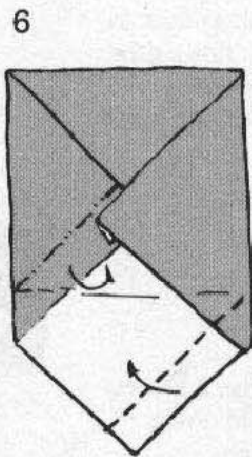

Tuck under final edge

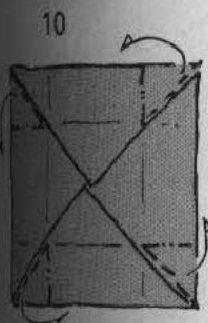
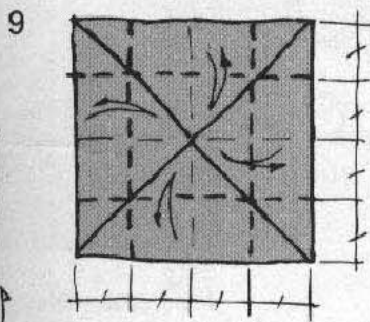
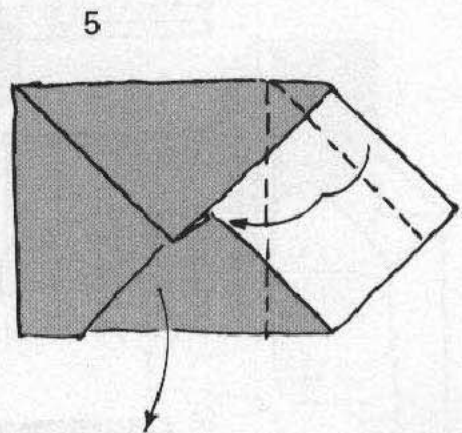

Bottle

The bottle was a development of an earlier triangular section bottle folded to have Pat Crawford's three-masted ship placed inside. It was requested by Eric Kenneway for his book *Origami Paperfolding for Fun*, in 1979.

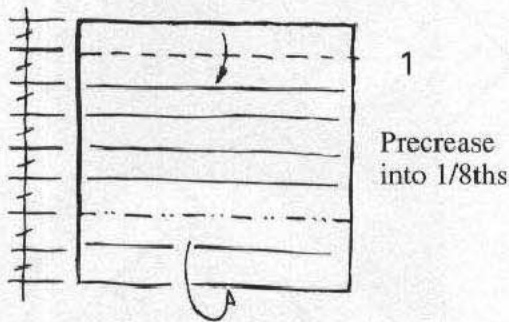

1
Precrease into 1/8ths

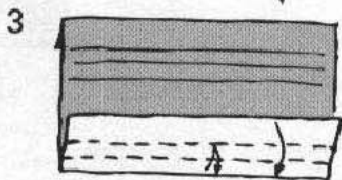
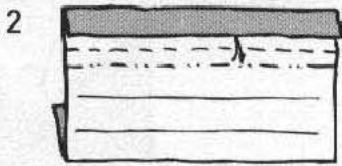

3
Precrease 2 layers then fold down raw edge

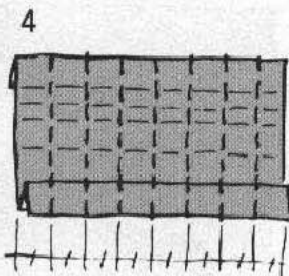

4
Now divide into 1/8ths vertically

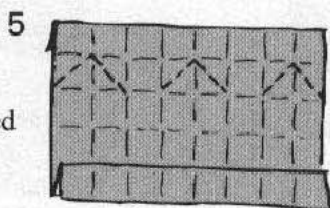

5
Make inverted "V" shaped valley folds

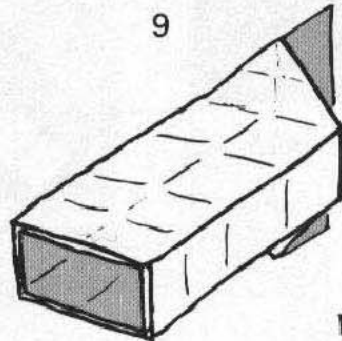

9

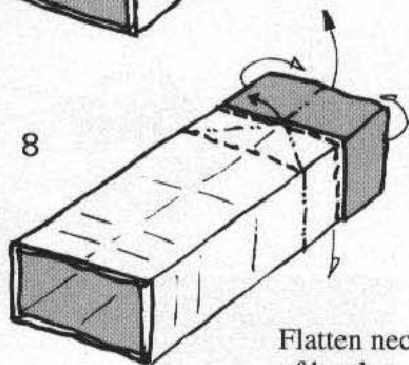

8

Flatten neck of bottle

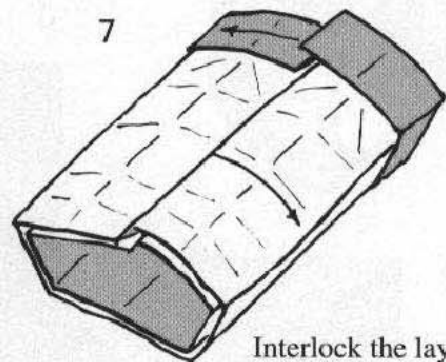

7

Interlock the layers carefully to form this rectangular tube shape

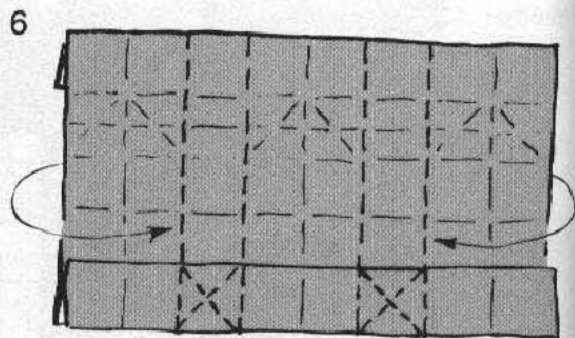

6

Precrease valley fold crosses on all layers then add 4 vertical valley folds

The best material for folding the design is non-adhesive book covering film available from stationers. This holds its crease reasonably well, but needs a little practice to get good results.

Release layers to trap top of inverted "V" shape which was precreased in 5

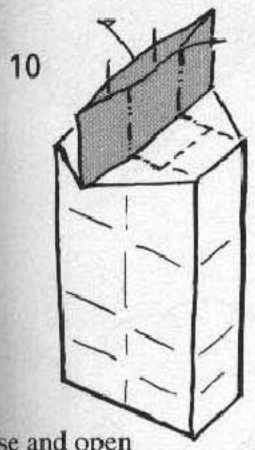

10
Raise and open neck using existing creases

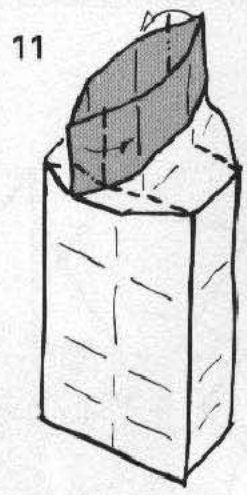

11
Make square-section neck with a sort of rabbit ear front and back

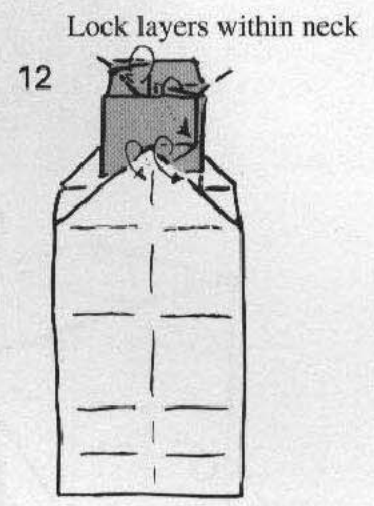

Lock layers within neck

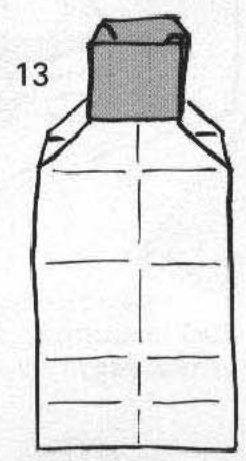

13

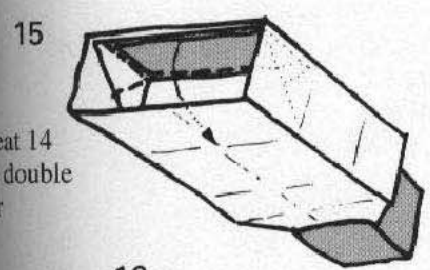

15
Repeat 14 with double layer

14

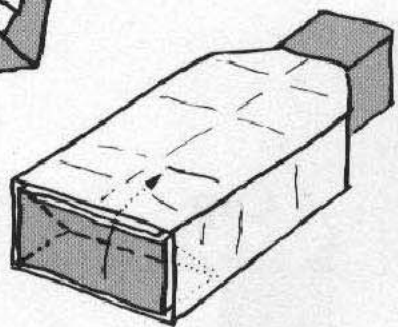

14
Close base of bottle starting with single layer within

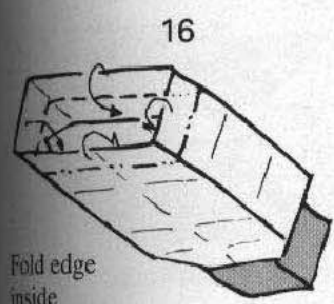

16
Fold edge inside to lock

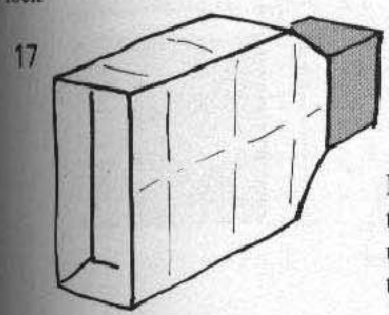

17

Fold with conventional origami paper to begin with. For your second attempt, use transparent book-covering film cut to a 12 inches (30 cm) square.

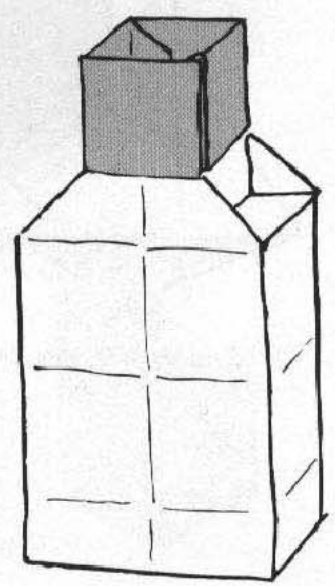

Yacht

suggested square size 3 inches (7.5 cm)

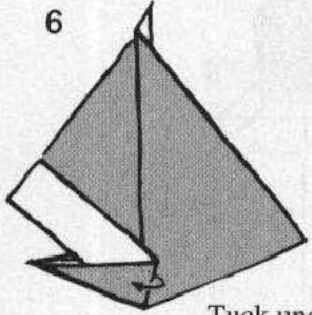
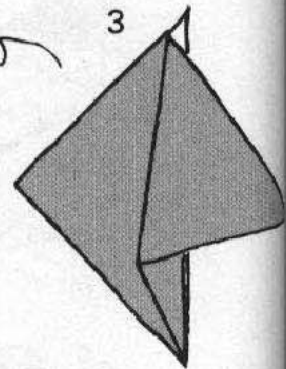
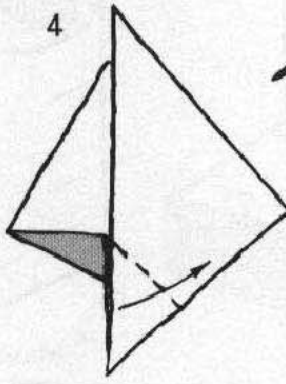
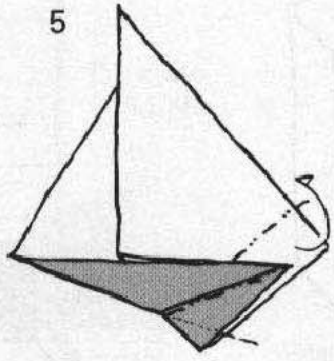
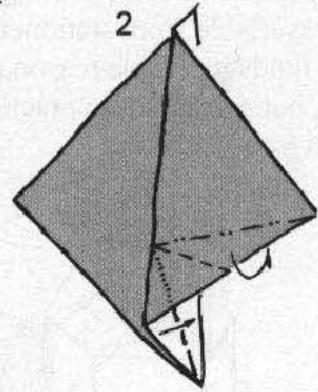
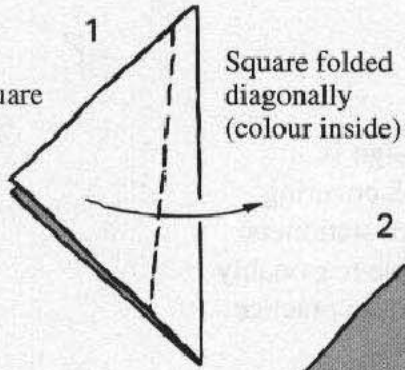

Tuck under the vertical edge

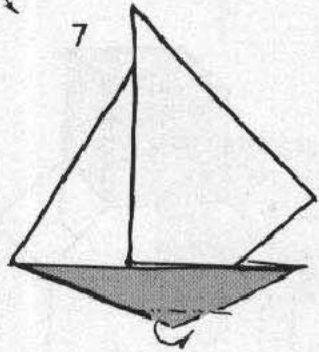

Fold under at 90 degrees

Cap

suggested square size 7 inches (17 cm)

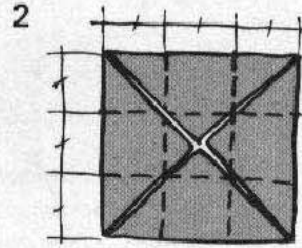
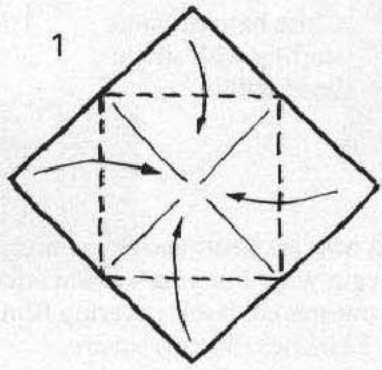
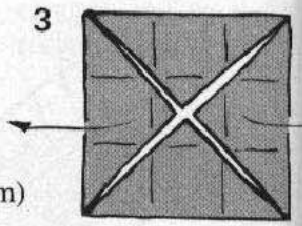

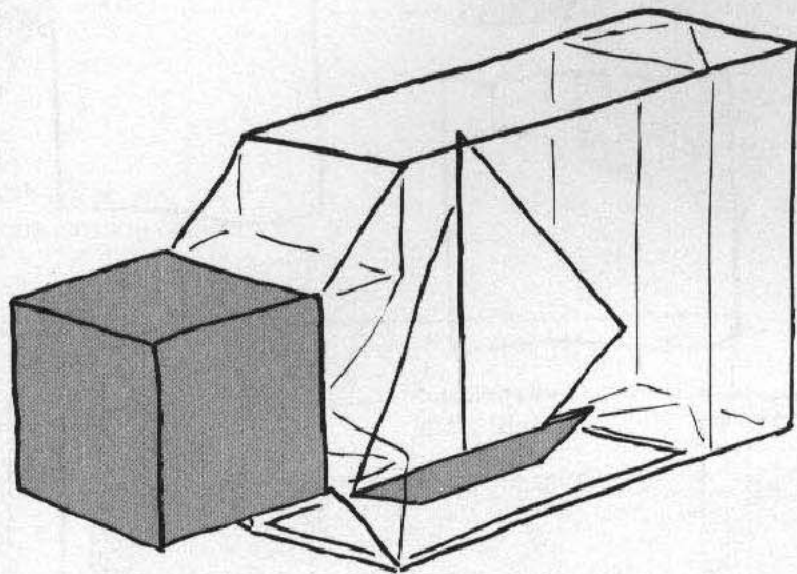
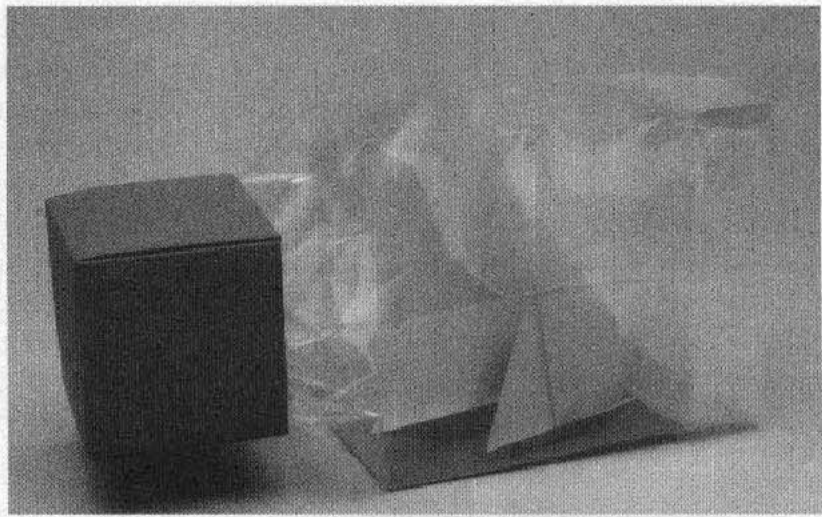

Glue the yacht to a small rectangle approximately the same size as the base of the bottle, and insert this inside the bottle before you close the bottle end. (step 14)

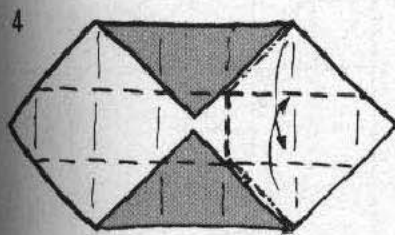

Form one end of the cap

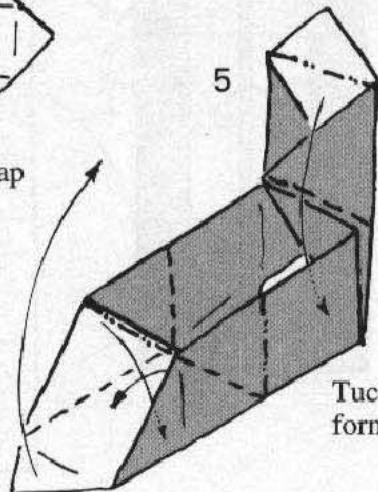

Tuck inside, then form the other end

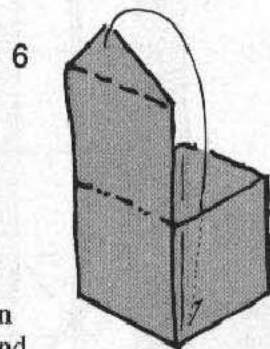
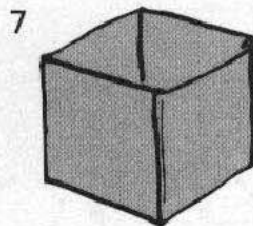

Box and Lid

The Box and Lid is a particular favourite and was created to hold a present for a girlfriend in 1977. It is a particular favourite of mine and I love the collapsing movement in steps 16 and 17. It was published in Kenneway's book *Origami Paperfolding for Fun* with a different folding method.

1 Divide into 1/5ths

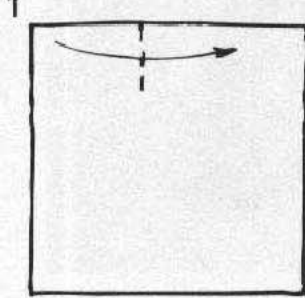

Method by Shuzo Fujimoto

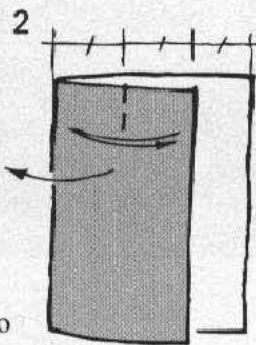

3

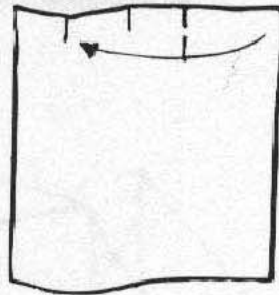

4

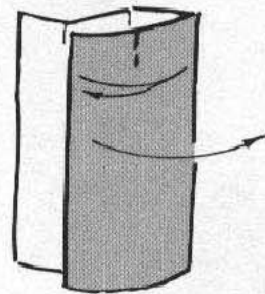

5

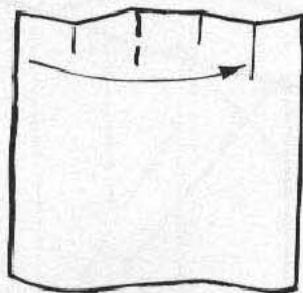

6

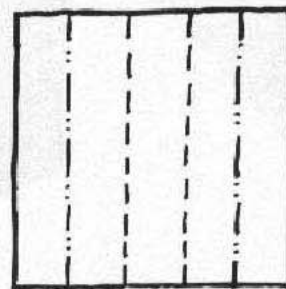

Repeat 1-5 until 1/5th divisions coincide

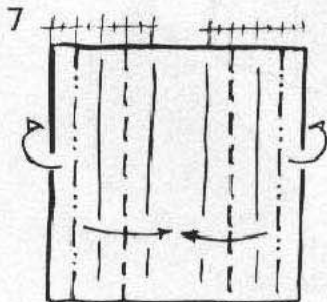

8

Mark valley fold crosses at each end of central white strip

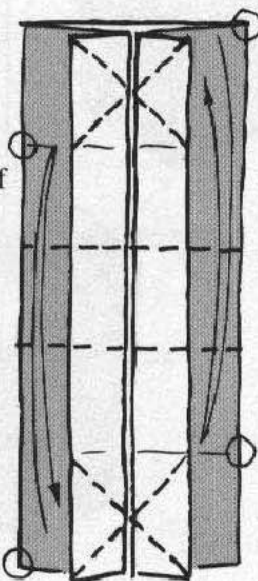

Complete horizontal 1/5th divisions using crosses as guidelines

9

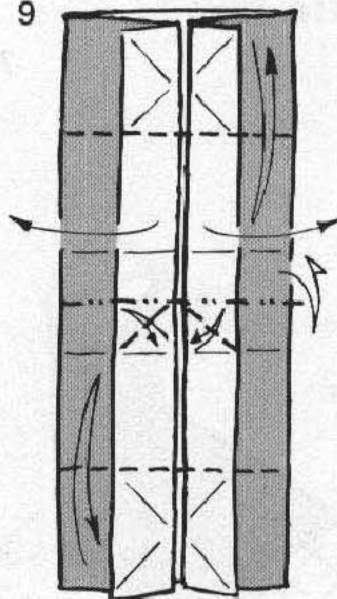

10

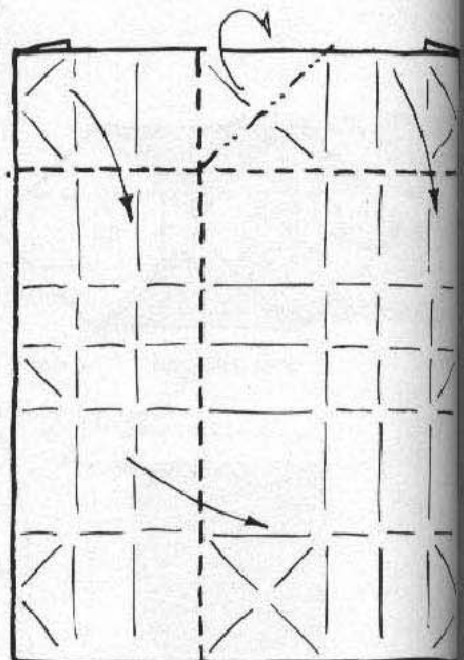

Form into a 3D shape

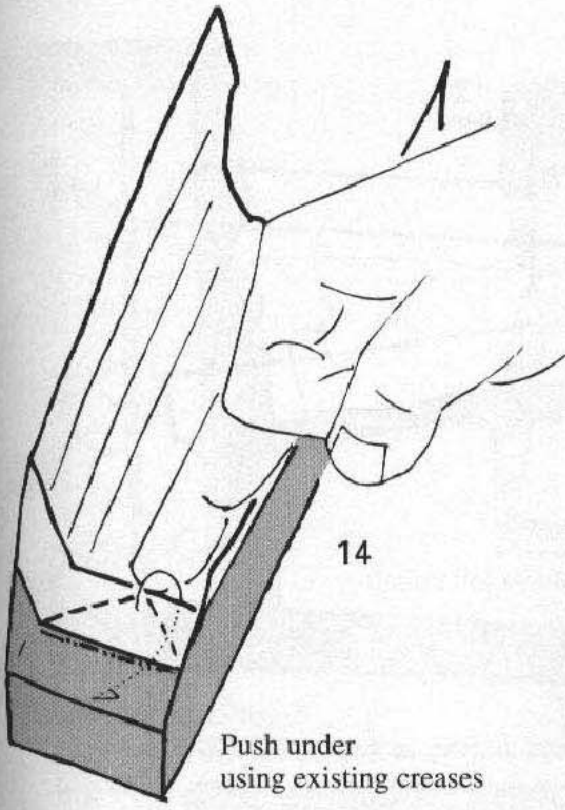

14

Push under
using existing creases

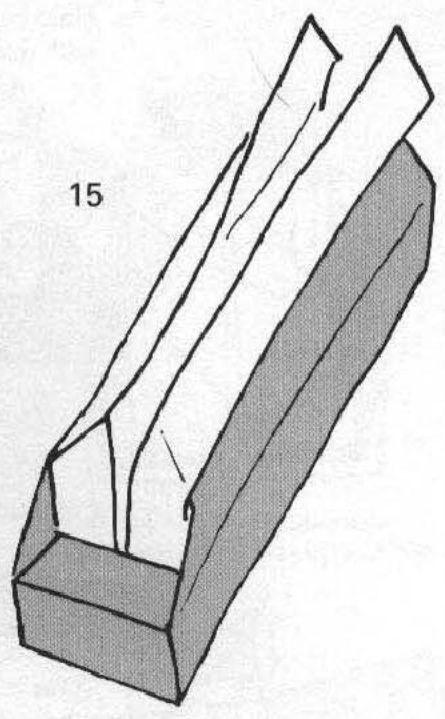

15

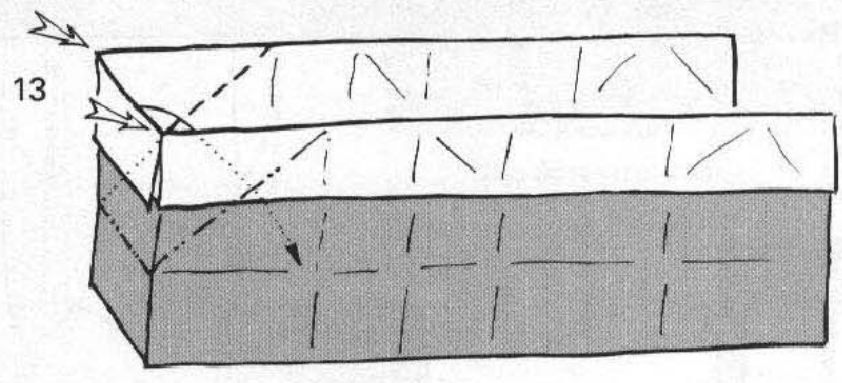

13

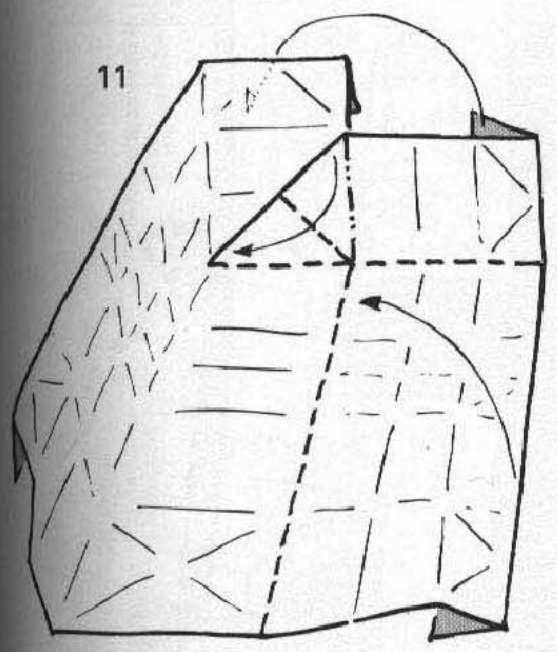

11

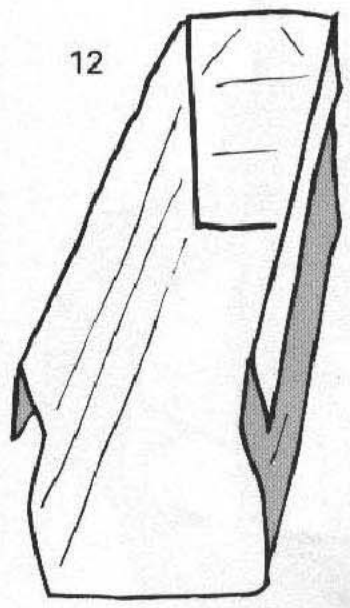

12

Form box shape

Hold hidden triangle in position
with thumb and forefinger of left hand

16

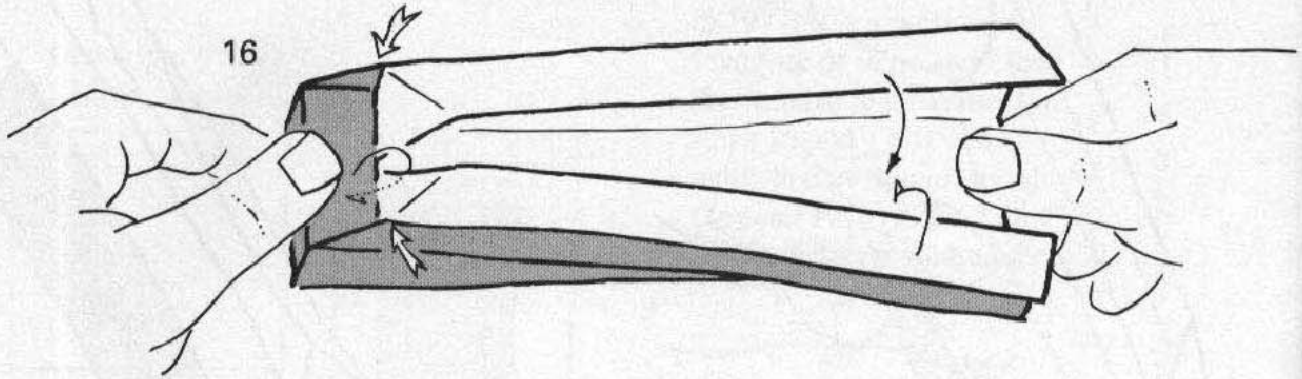

17

Collapse layers by pushing down left thumb

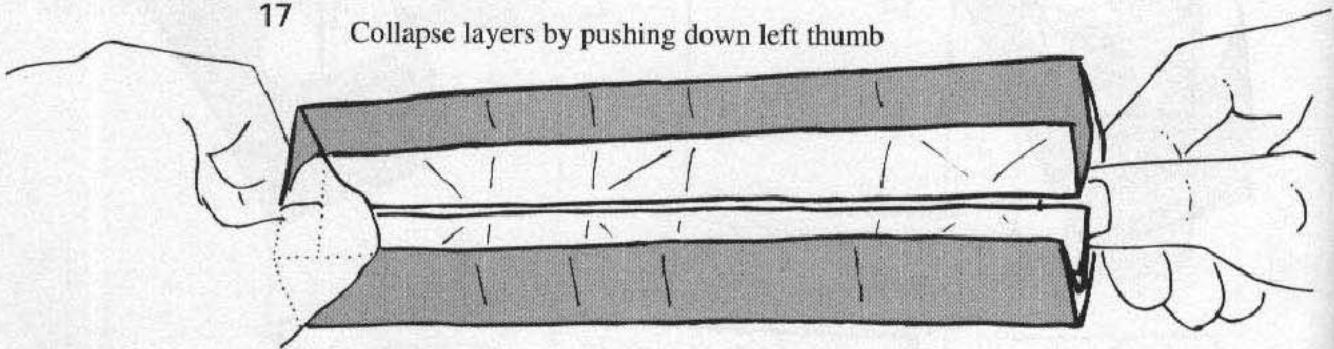

18

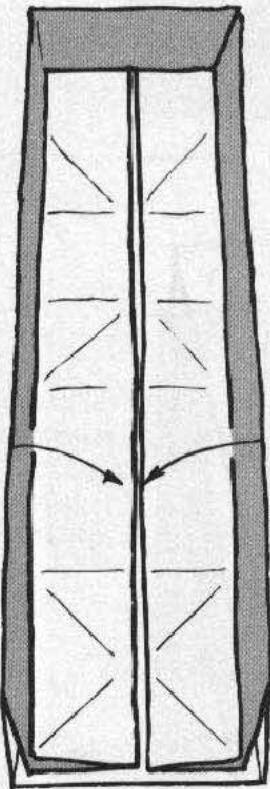

19

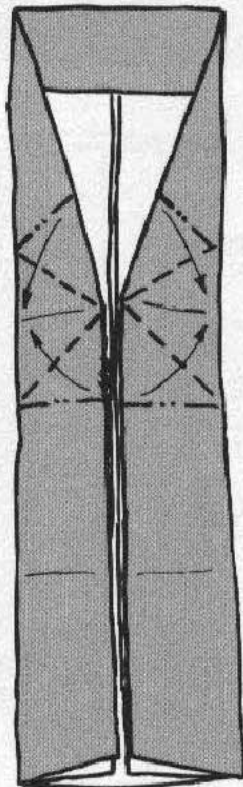

20

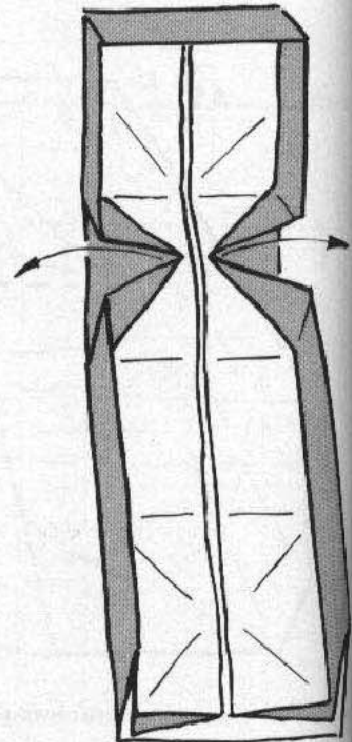

Form lid

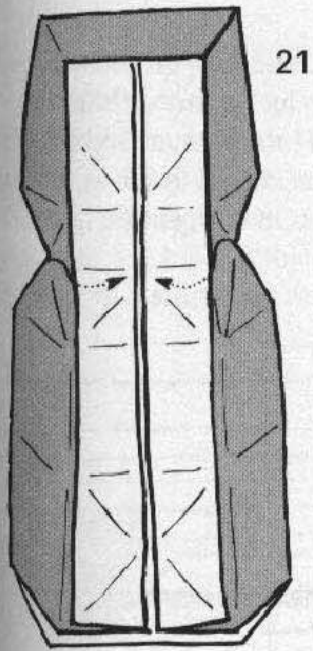

Tuck under central strip

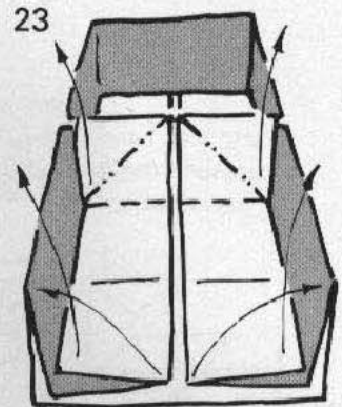
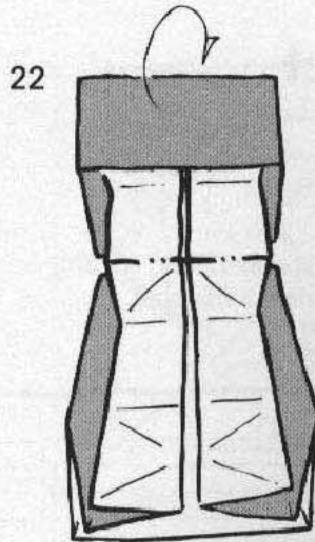

Lift out white central layers and flatten against sides of box

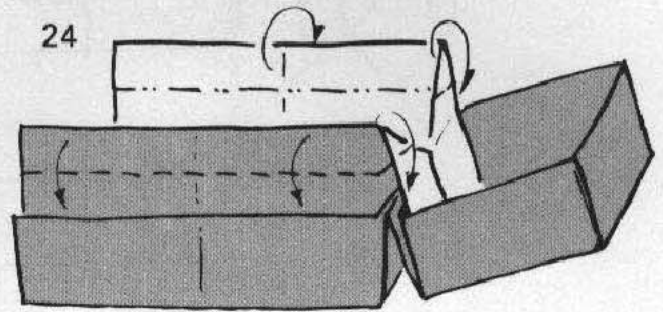

Outside reverse folds

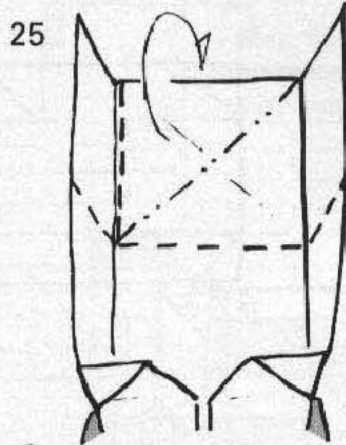

Formation of box end

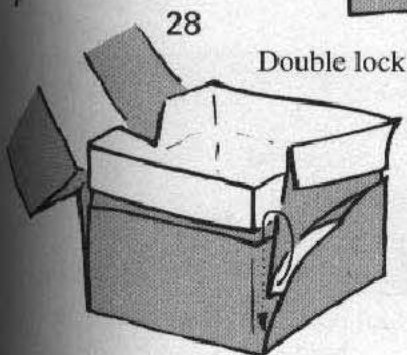
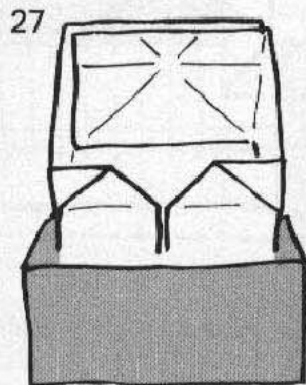
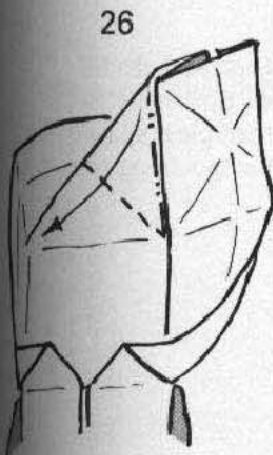

Double lock

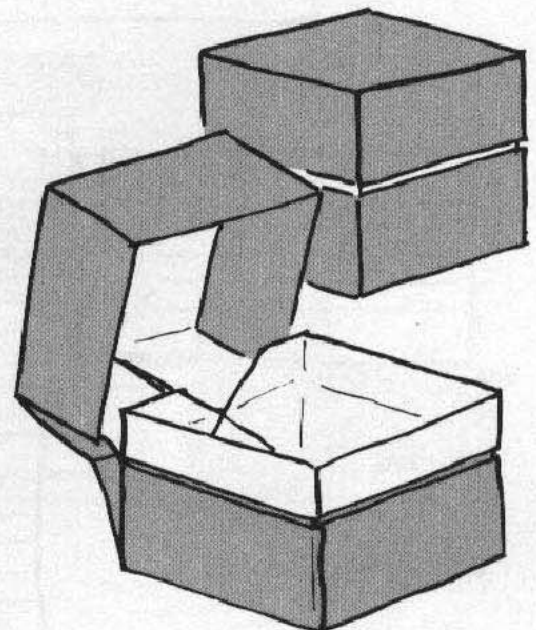
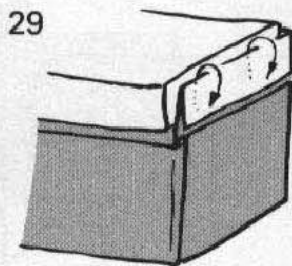

Cigarette Packet

This cigarette packet was a direct product of my admiration for Max Hulme's matchbox, which was shown to me at my first BOS convention in 1975.

Use a 4x1 rectangle, 20x5 inches (48x12 cm) for a finished model slightly smaller than a life-size "packet of ten"

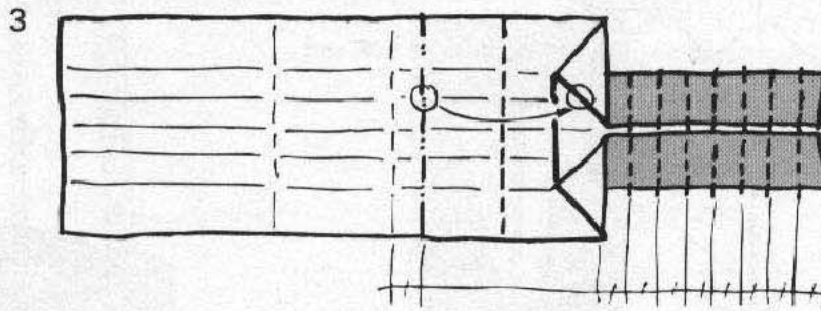
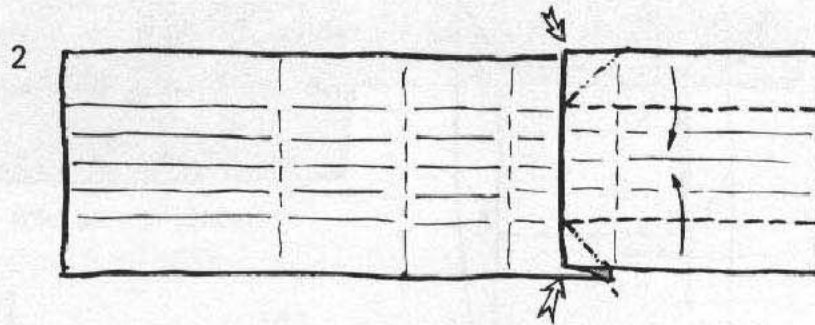
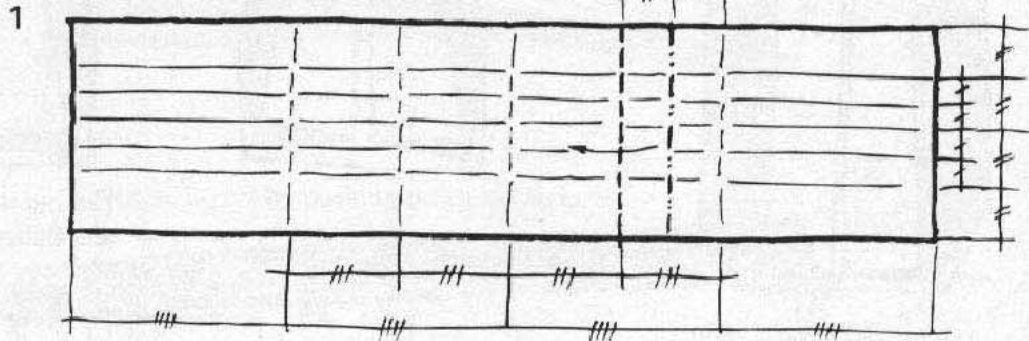

Precrease the lid section into eighths: then pleat again noting the location point

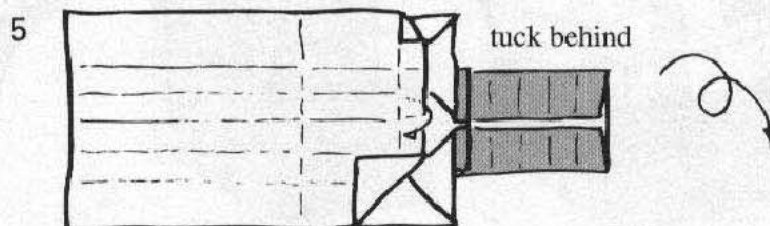
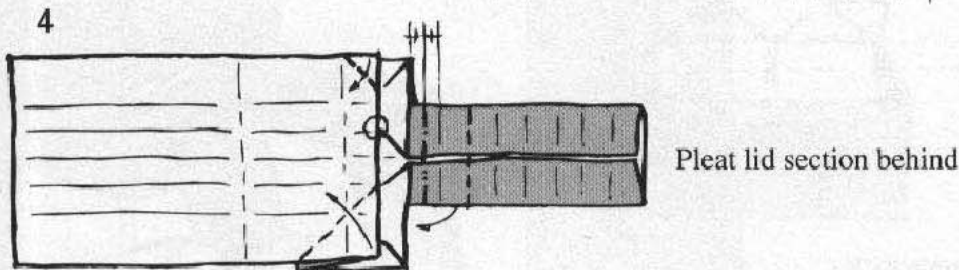

I was immensely proud of the design when I first created it, and I still enjoy folding it today, although I no longer tackle multi-subject folds from a single sheet.

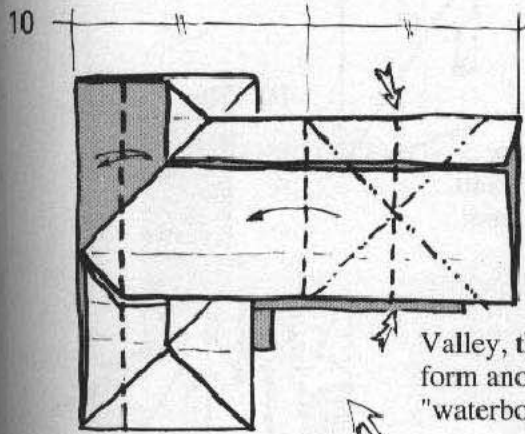

Precrease

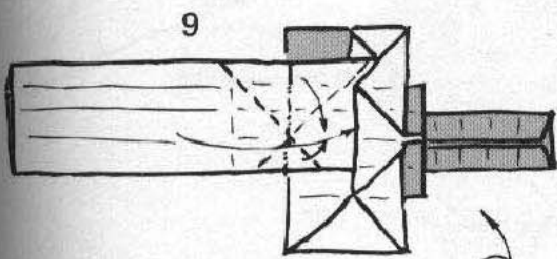

Form a "waterbomb base" shape

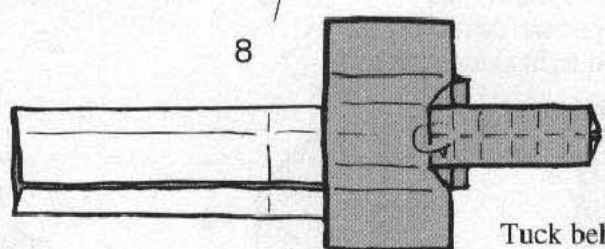

Tuck behind

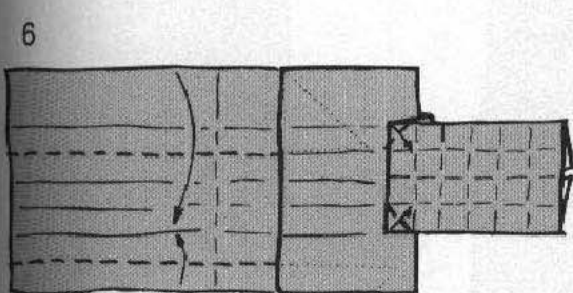

Narrow allowing diagonal folds made in 5 to rotate behind

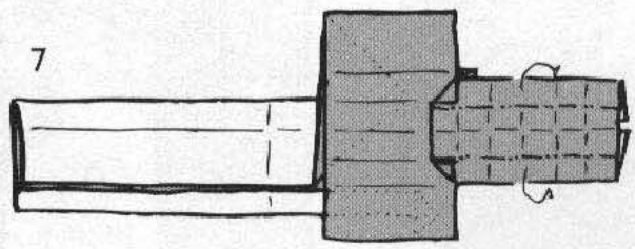

Similar process to 6

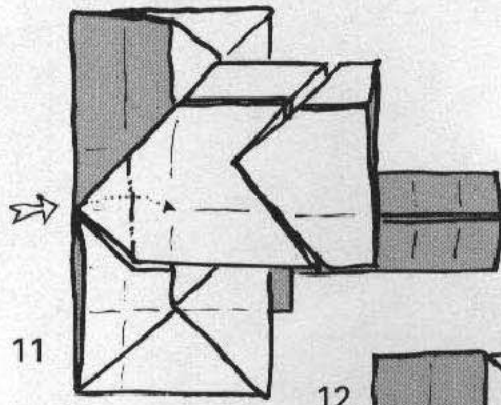

Sink

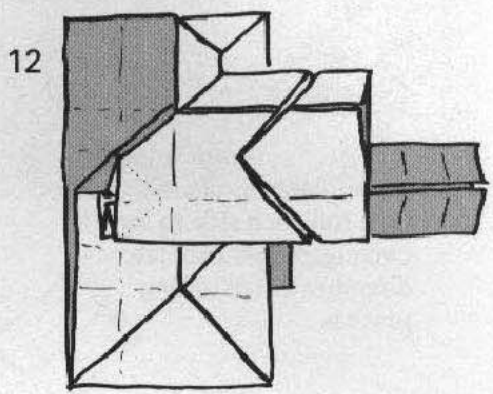

13

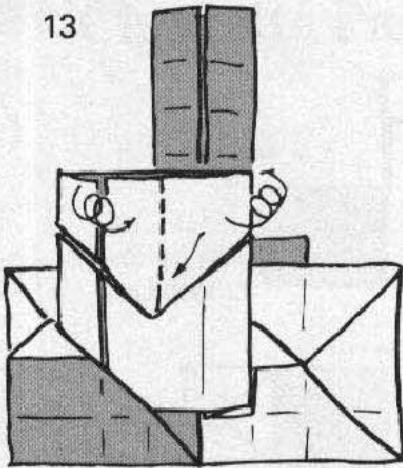

Lift the right hand side of the upper "waterbomb base" then roll each side to form two cigarettes: note the direction of the rolling process

14

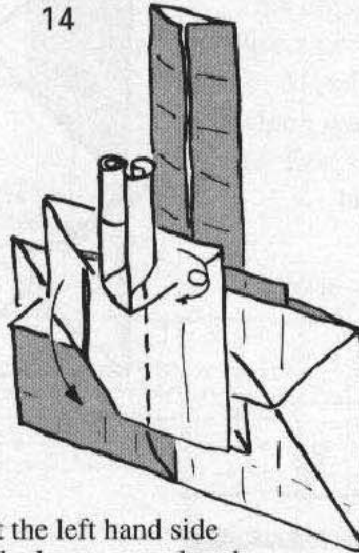

Lift the left hand side of the lower waterbomb base and roll one more cigarette

15

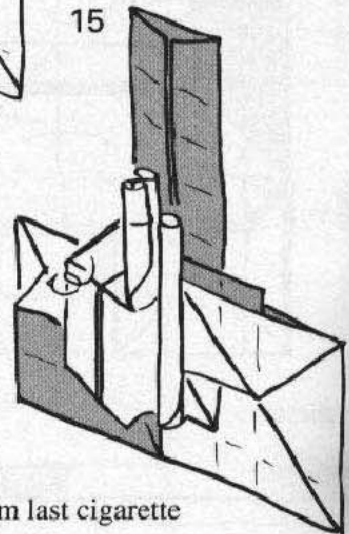

Form last cigarette

16

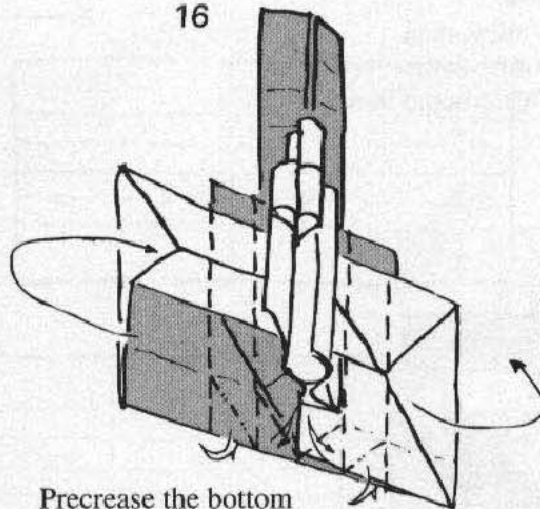

Precrease the bottom of the packet, then bring the left and right sides together

17

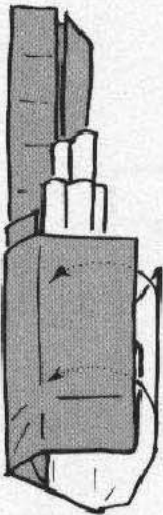

Insert to form packet

18

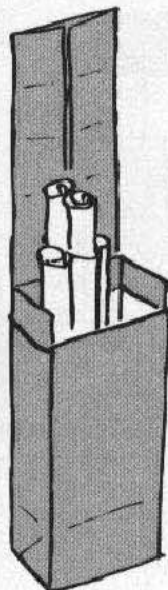

19

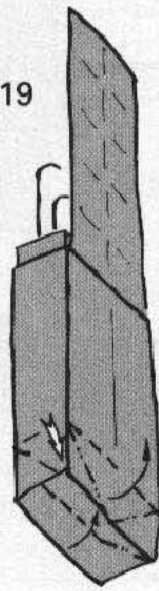

Formation of bottom of the packet

20

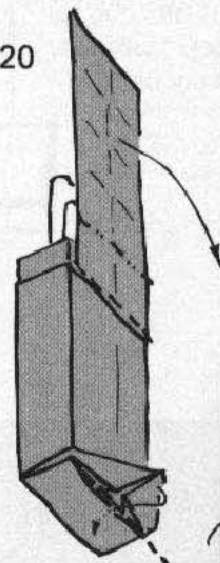

20A

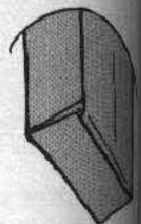

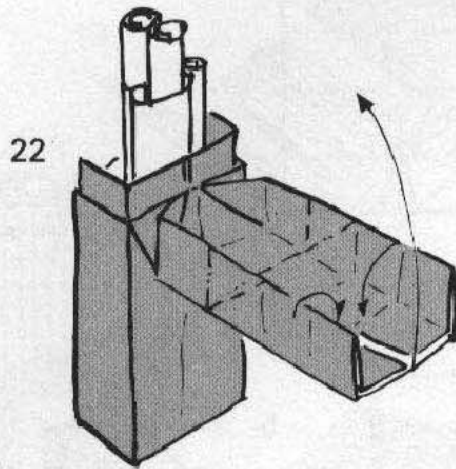
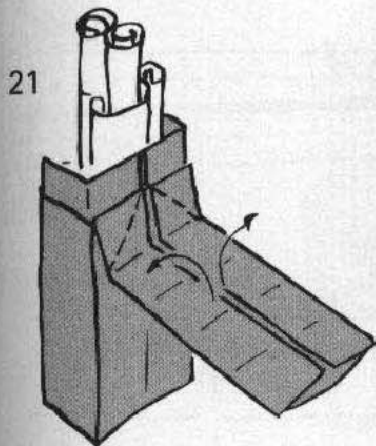
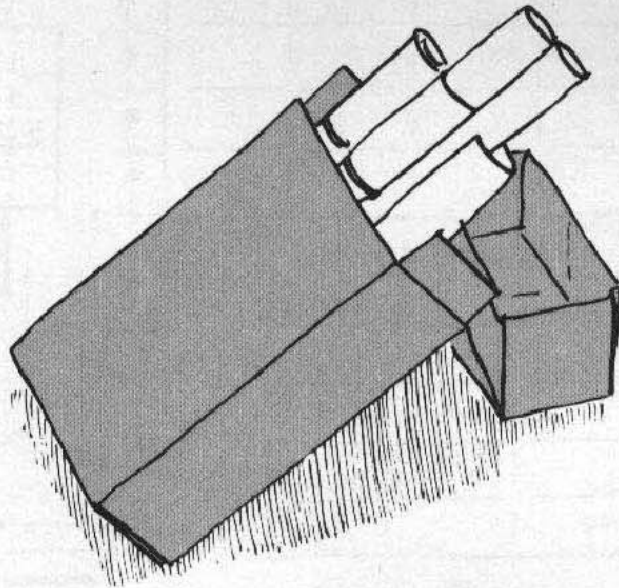
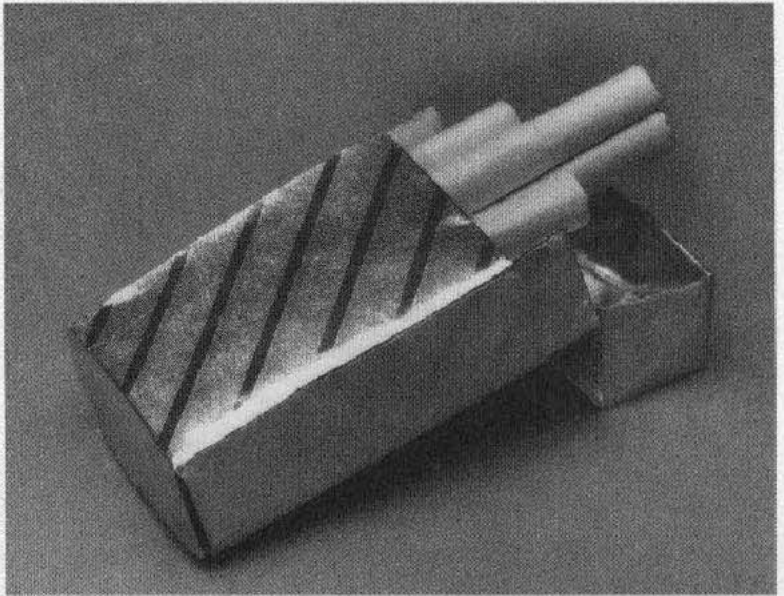

Formation of the lid

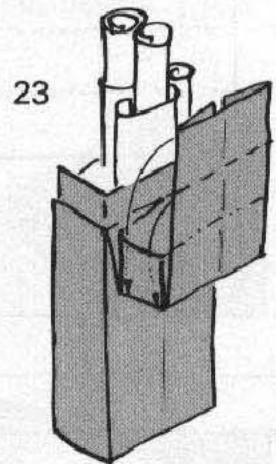

Matchbox

The matchbox came after the cigarette packet: like the Nut and Bolt it was in response to the BOS *Whodunnit* challenge. Many other moveable matchboxes emerged from the same stimulus, but I believe mine was the only one with authentic(?) contents!



Use a 3x1 rectangle of red paper, recommended size 12x4 inches(30x10cm)

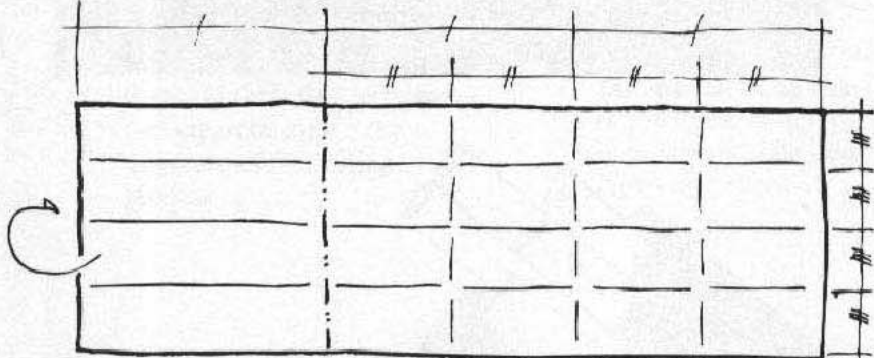

1 Precrease, then mountain fold behind

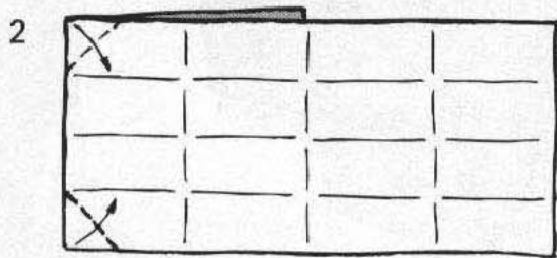

2

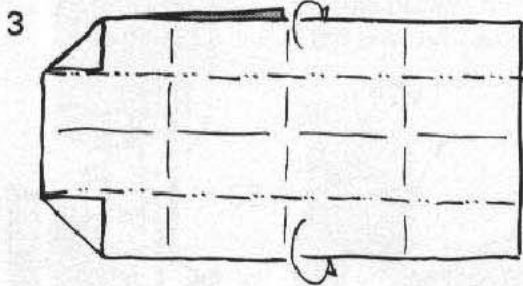

3

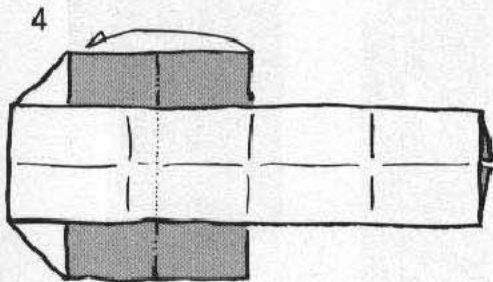

4

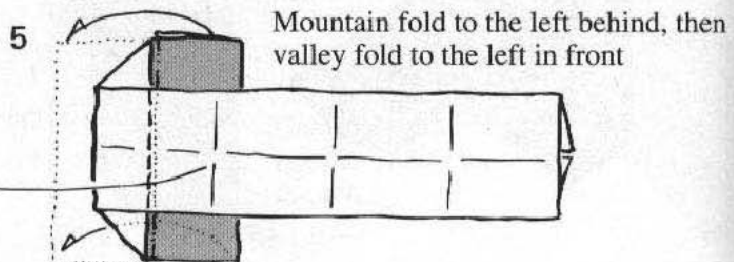

5

Mountain fold to the left behind, then valley fold to the left in front

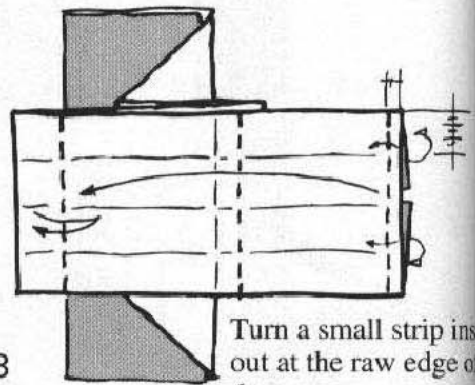

8

Turn a small strip inside out at the raw edge of the paper

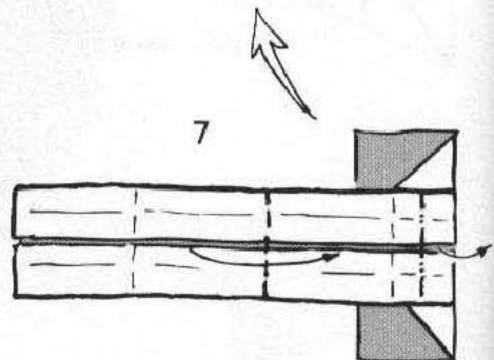

7

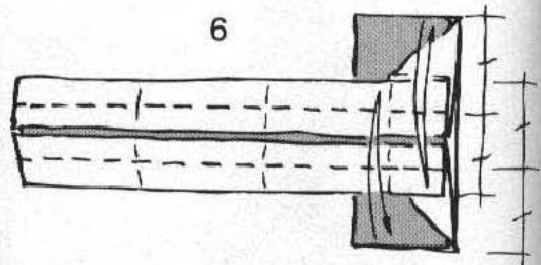

6

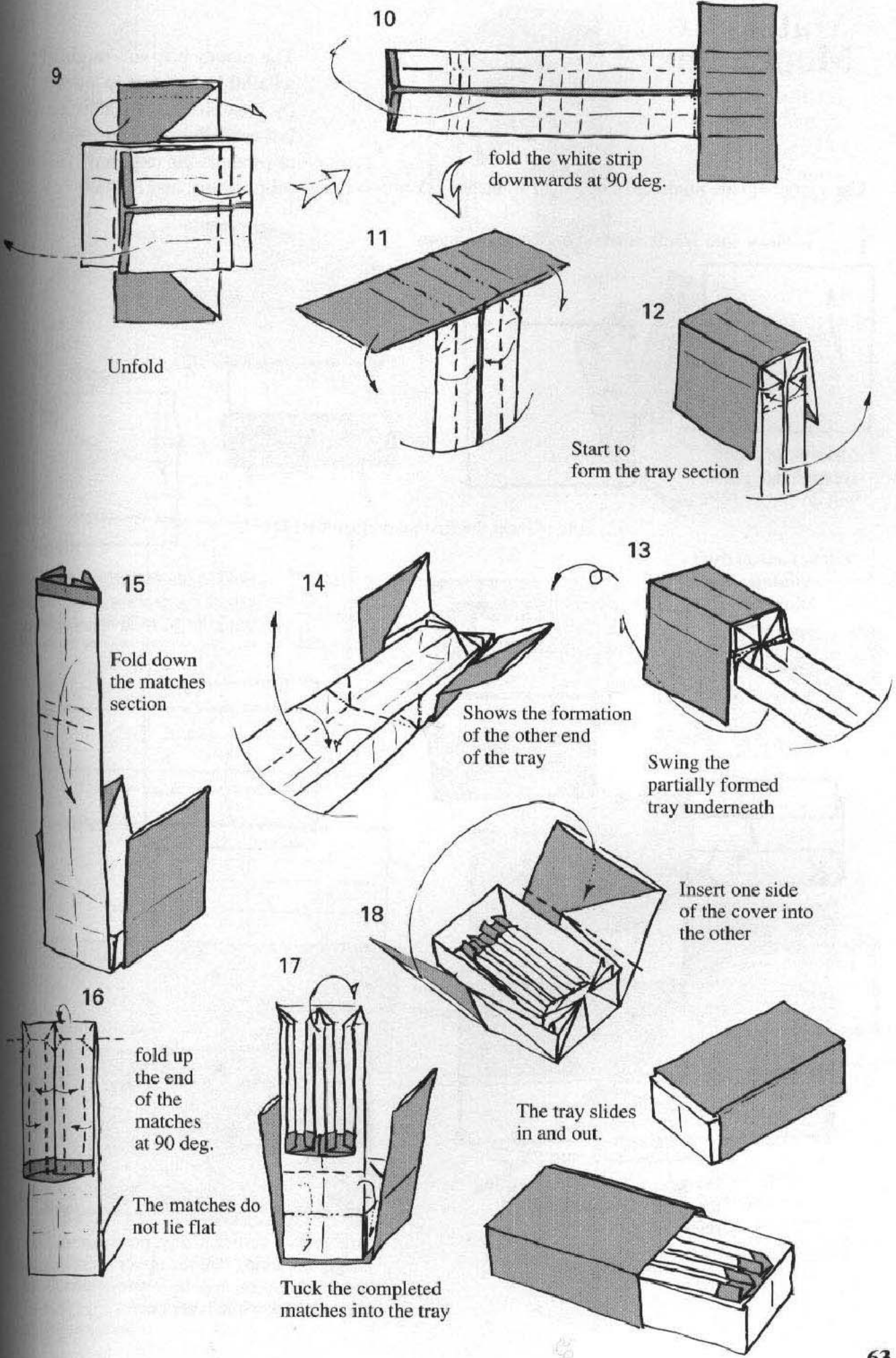

inside
edge of

Money Box

The money box was originally a ballot box: it was inspired by Max Hulme's matchbox, but uses division into 1/3rds to produce the required proportions, and the slot.

Use a large square: minimum side length 10 inches (25 cm)

1 Division into 1/3rds: method by Shuzo Fujimoto

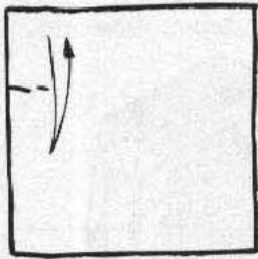

Mark only: a very approximate guess will do

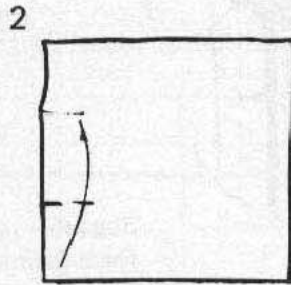

Fold to meet the first mark, then unfold

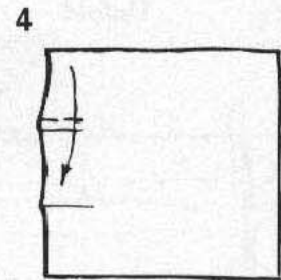
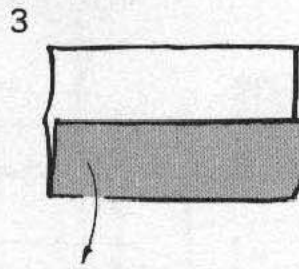

Fold to the second mark, then repeat the process in steps 123&4 until the 1/3rd divisions coincide.

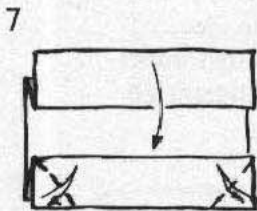
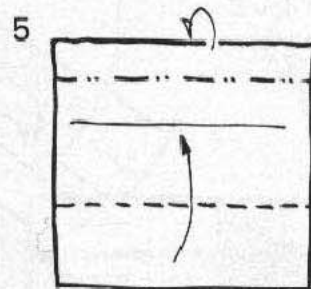
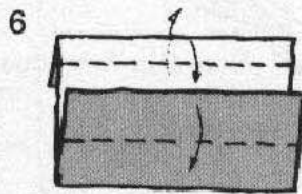

Precrease diagonals on one layer only

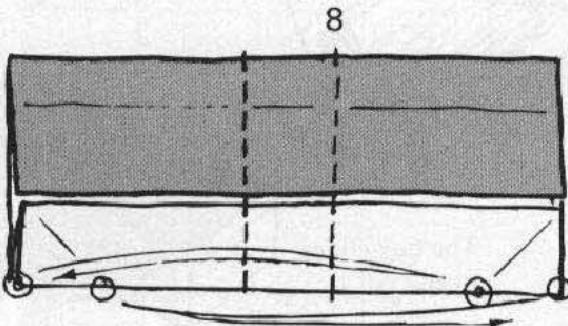

Precrease these verticals using the ends of the diagonals as reference points

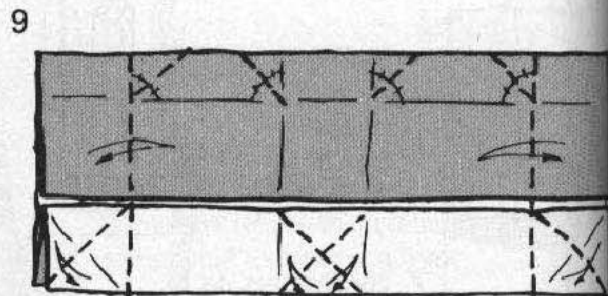

Add further verticals, then precrease further diagonals noting that the upper short diagonals are on all layers, and the lower diagonals are on the upper white layer only

14

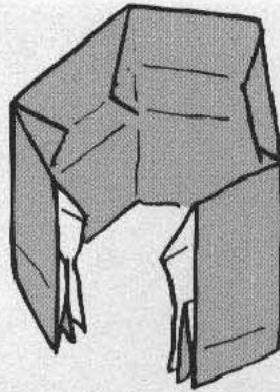

Encourage the collapsing of the diagonal mitres

13

Form into a rectangular tube shape

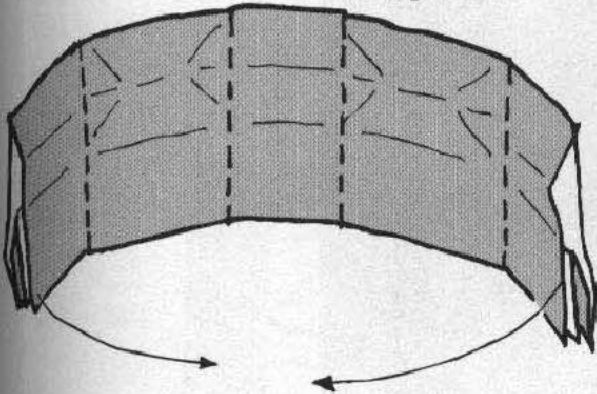

15

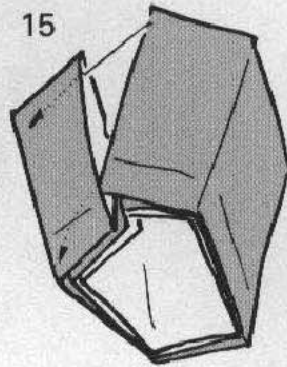

Interlock carefully as shown

16

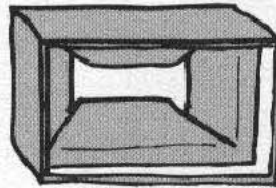

Push up the interior layer carefully to form the slot

17

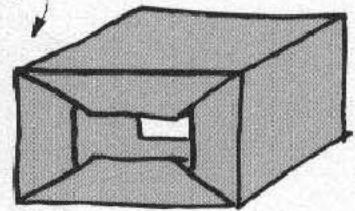

18

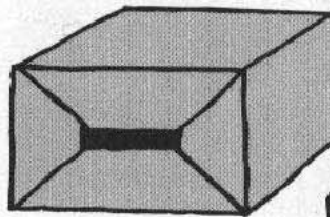

19

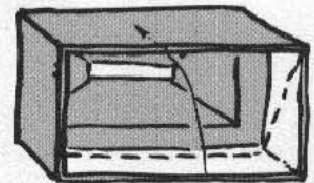

Fold down a single layer within

20

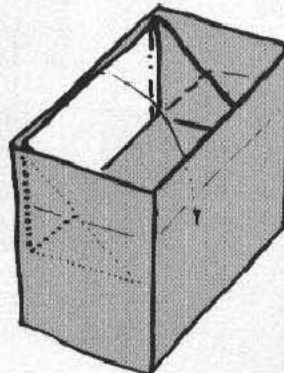

Repeat on the other side

12

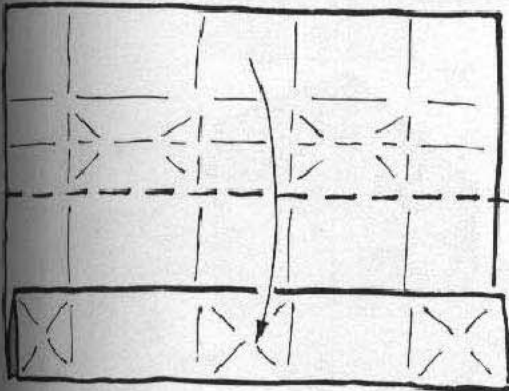

11

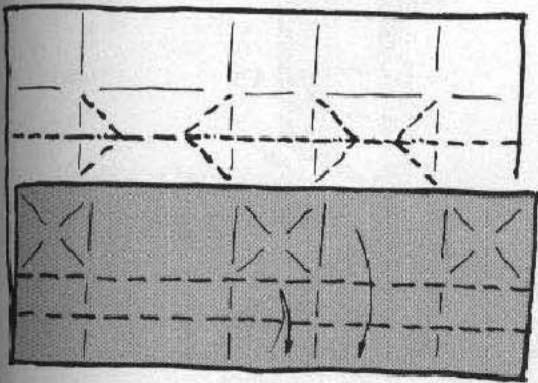

Precrease carefully and firmly to form the diagonal "mitres"

10

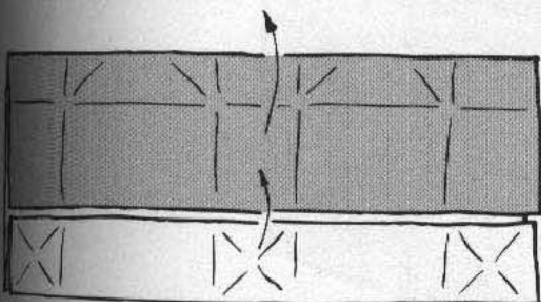

Lift the upper raw edge, followed by the lower raw edge

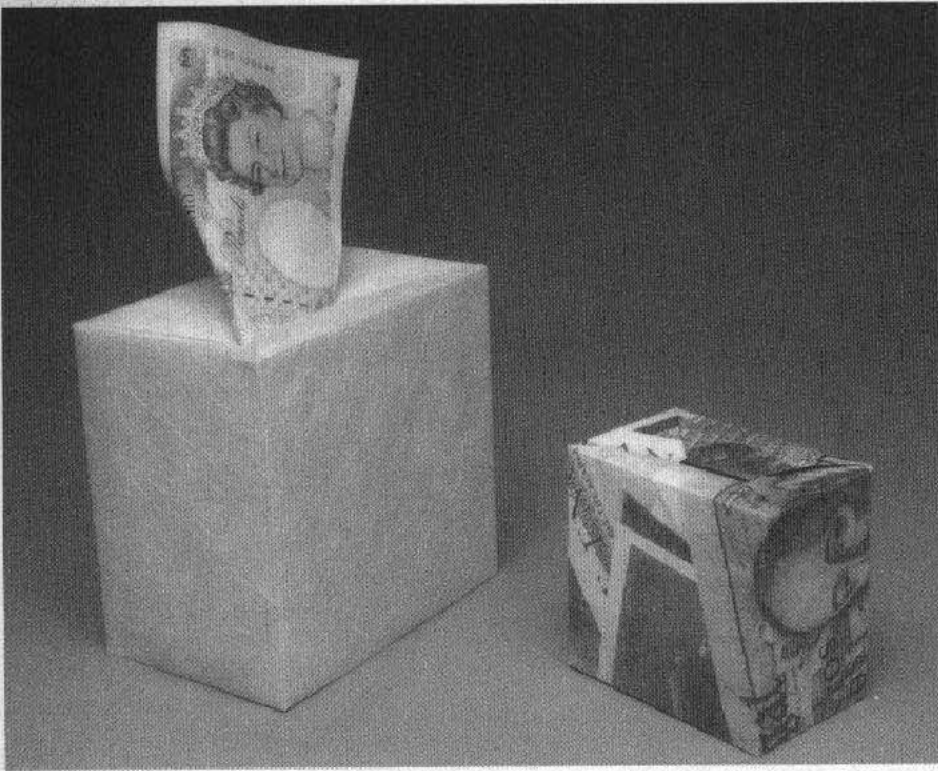

21

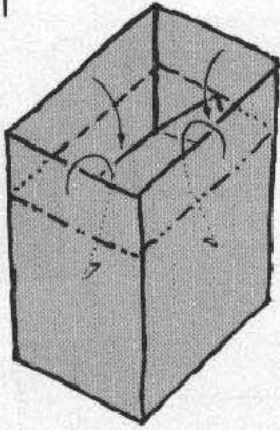

Fold edges inside
to lock the bottom
of the box

22

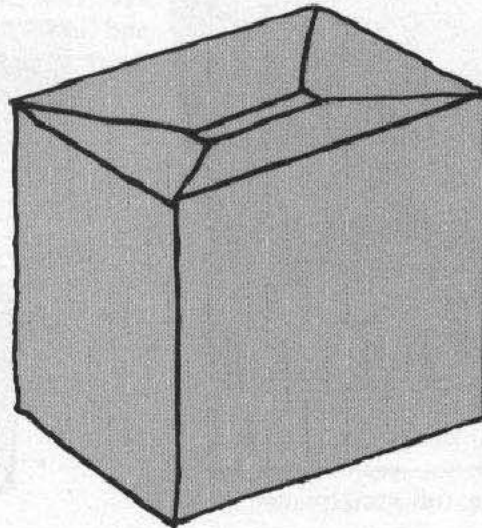
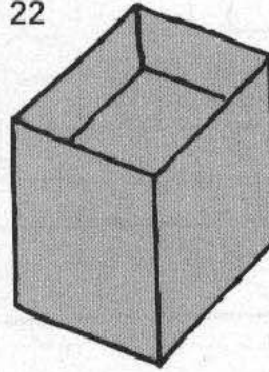

This
hom
a pr
rath
and
has
Fol
the

Fold c
on all

valley an



C

Honeymoon Box

This box was created on my honeymoon in Italy, to contain a present for my wife. It is rather complicated and bulky and needs careful folding but has some interesting movements. Fold it several times to get the best result.

Use a sheet at least 12 inches (30 cm) square
Precrease into eighths,
then remove one row of eighths from 2 adjacent sides

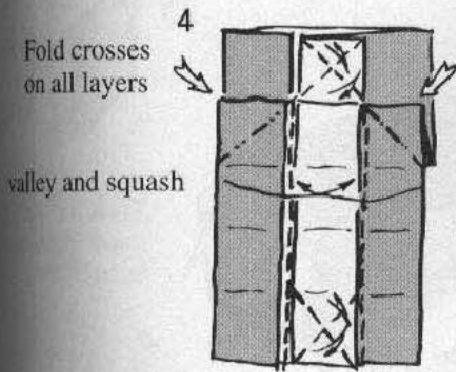
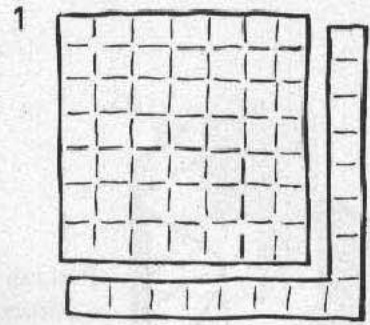

Fold crosses on all layers

valley and squash

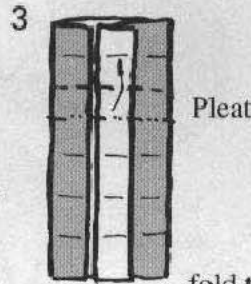

Pleat

fold to make rectangular shape with a white central strip

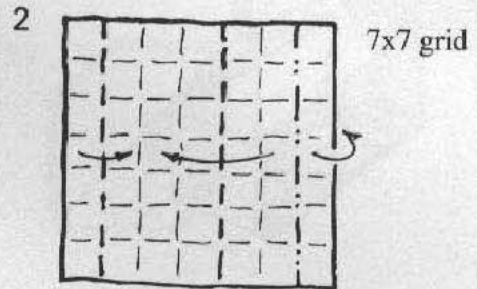

7x7 grid

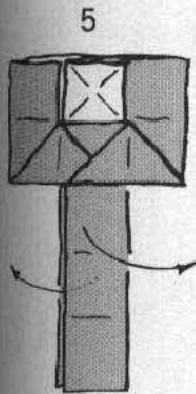

Open

Lift out the central white strip

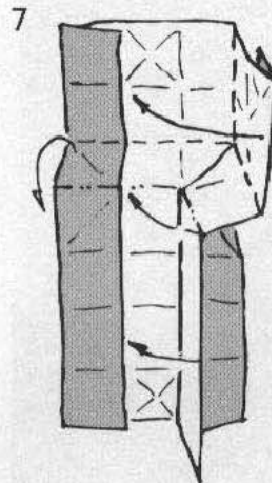
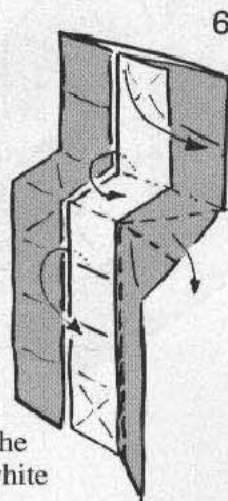

Close, adjusting the position of the layers in relation to the pleat

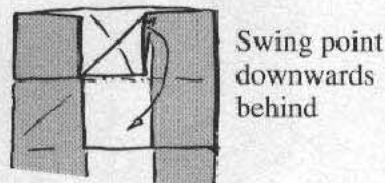

Swing point downwards behind

Precrease mountain folds

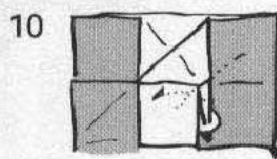
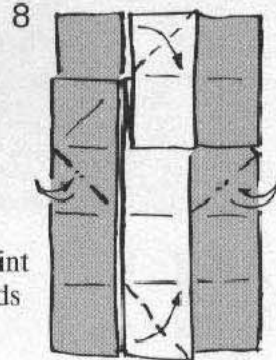

Lock the point with a mountain fold

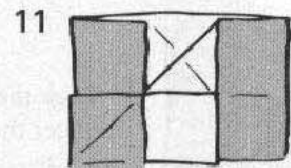

Repeat at the other end of the white strip but in mirror image

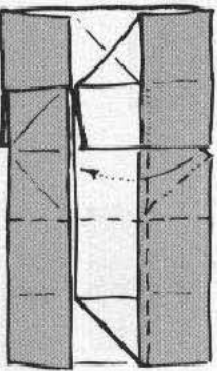

12

Tuck the triangle under the central white strip: the model will become 3D

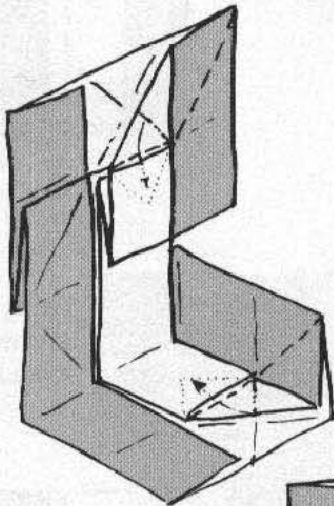

13

Lift the left hand edge

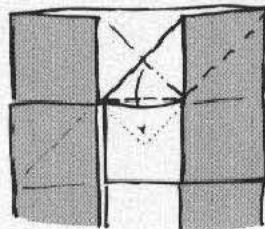

14

The same procedure (in mirror image) is used at the other end of the white strip

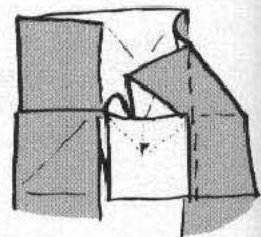

15

These drawings show in more detail the insertion of the top end of the white strip into the pocket

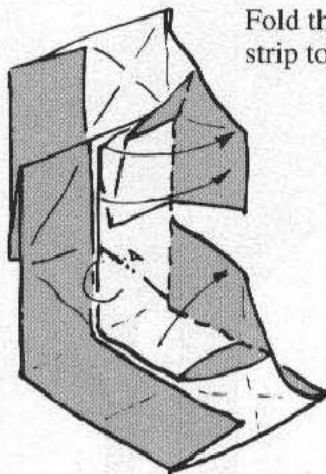

16

Fold the central white strip to the right hand edge

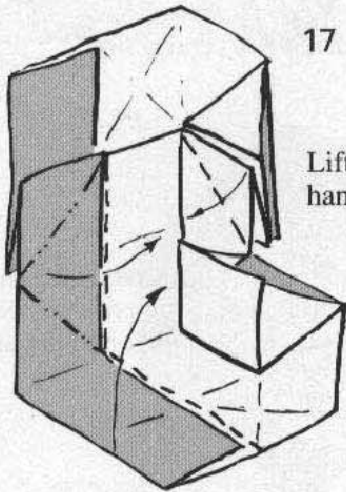

17

Lift the left hand edge

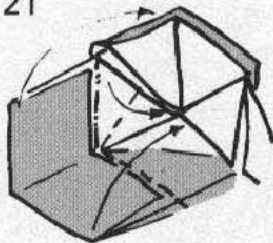

21

View inside the end of the lid

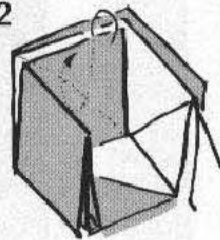

22

Tuck the corner under the diagonal edge behind

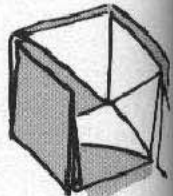

23

Formation of the end of the box lid

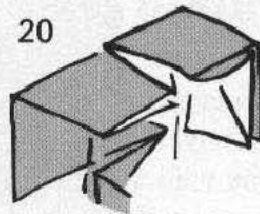

20

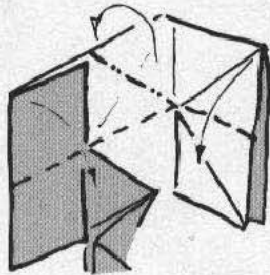

19

Pull out a corner from behind

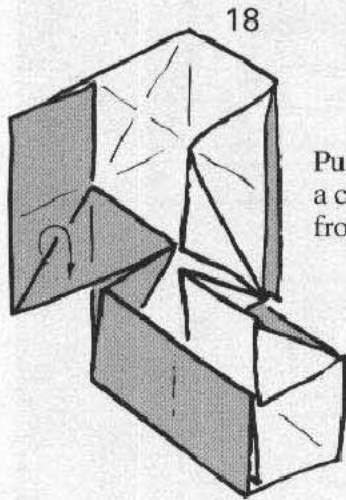

18

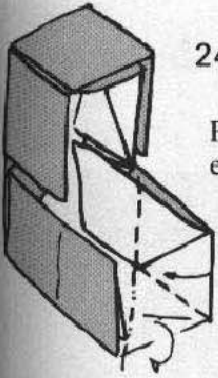

24

Formation of the end of the box

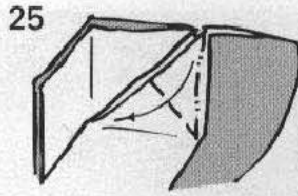
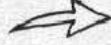

25

View inside the box

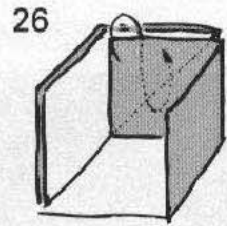

26

Tuck the corner under the diagonal edge behind

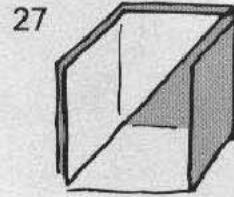

27



28

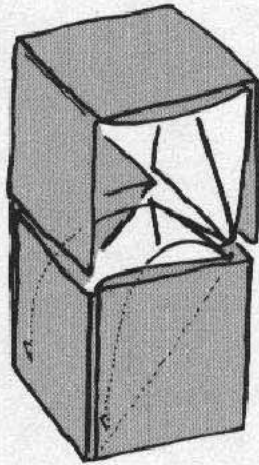

Swing back the central white strip inside the box



29

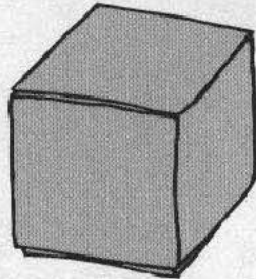
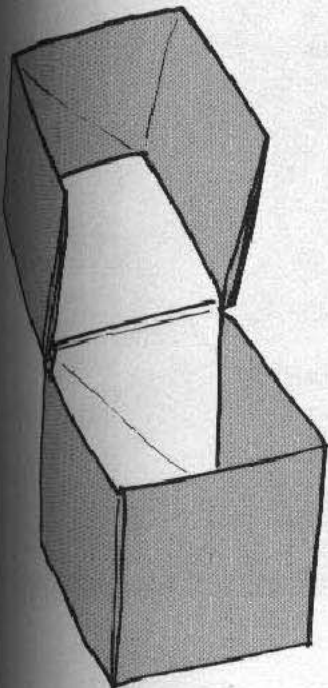
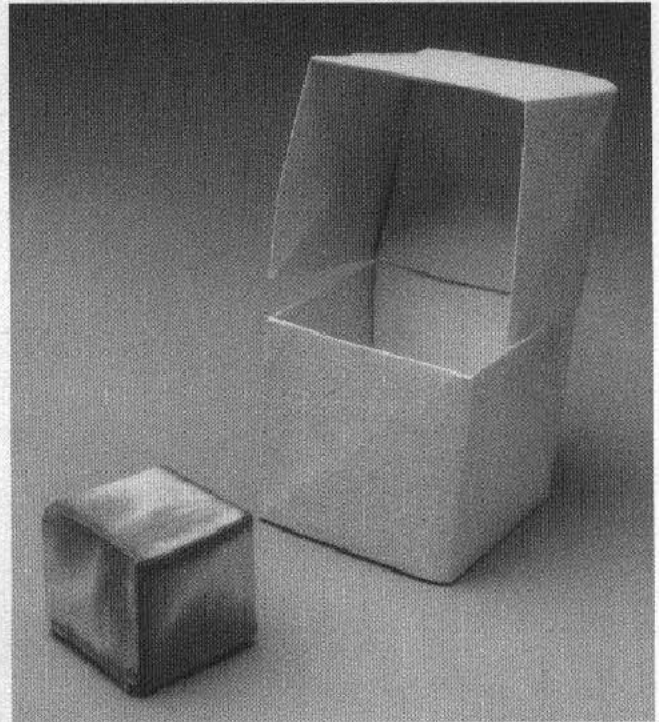

Modular Origami

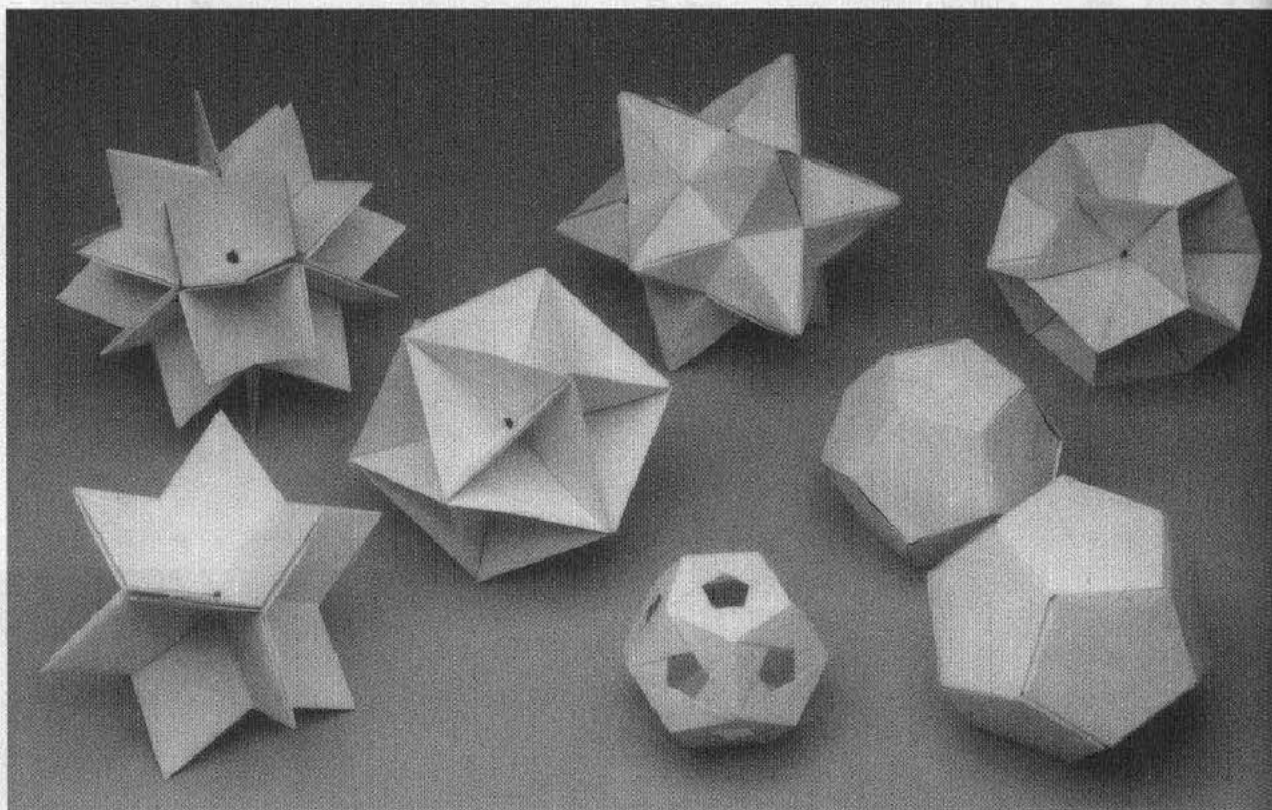

Modular Stars & Balls

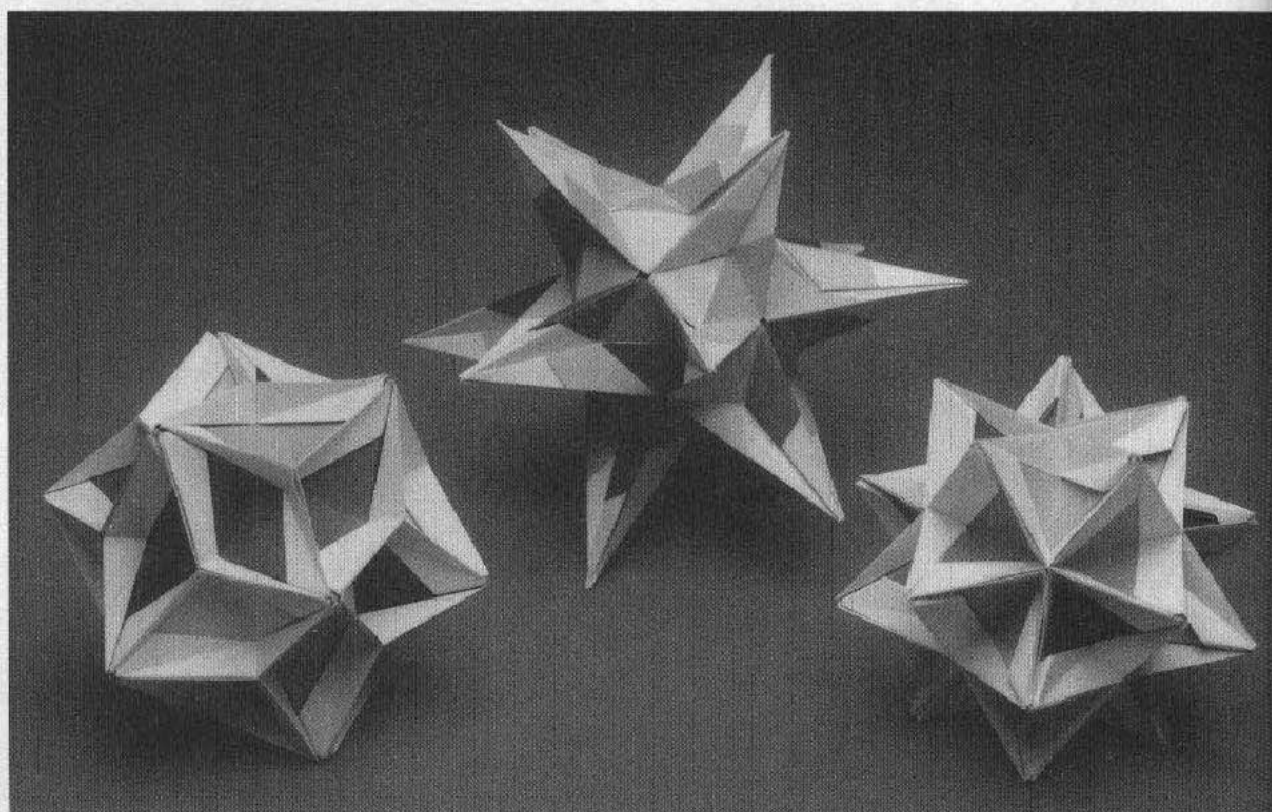

Stained Glass Balls (p. 85) and Spiky Star (p. 87)

Modular Theories

We have Tomoko Fuse to thank for the recent popularity in Modular or Unit origami. This is the construction of geometric forms from many simply folded units. The joining of the units is achieved by folding alone, and by the insertion of the flap of one unit into the pocket of the next.

Tomoko Fuse has managed to open a new door in this already established style, by creating wonderful boxes which display a neatness, a practicality, and an expression not previously seen in modular work. She has additionally shown herself to be great technician in the other areas of the style, by making elaborate polyhedrons and puzzle-like transformations from one shape to another by adding further units to the construction. A favorite design of mine is Fuse's unit Lizard, with a body which wriggles when shaken. The units are connected by such a simple method, they lock together securely, and yet are able to move smoothly, providing the movement in the body which is so effective. To me, this technique is a brilliant use of an apparently overworked and unpromising starting point.

Tomoko Fuse's Lizard

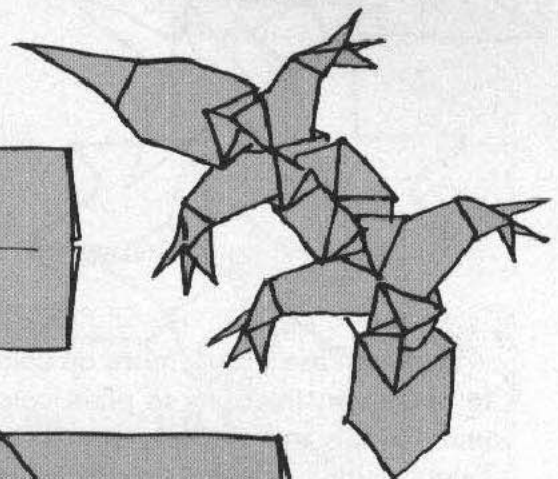
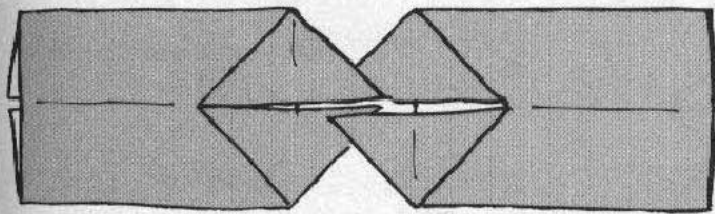

Fuse's Lizard:
principle of the moving joints

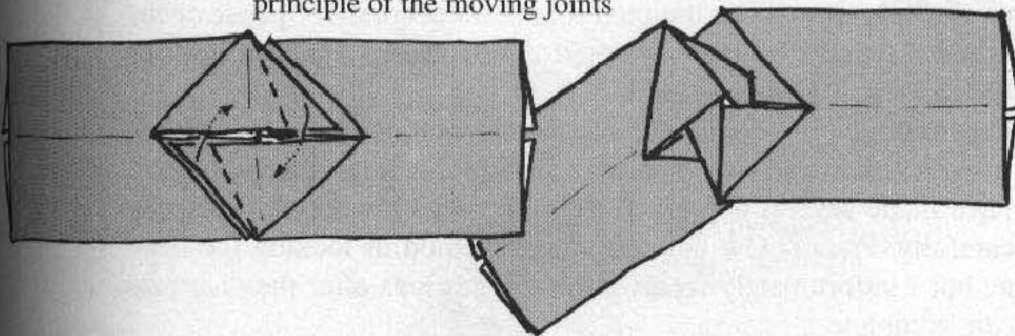

At first I was quite unattracted to the modular fashion, which seemed to me to be a form of origami "knitting". However following experimentation with a unit based on Yoshizawa's simplest butterfly, it later became an obsession. Thinking at the time that the resulting three-sided pyramid was original, I made a range of geometric solids with it, and several variations of the unit later gave more complex star-shaped polyhedra. I later found that both Tomoko Fuse and John Smith had made similar shapes with an identical unit! This is an increasingly

common occurrence, when simple shapes and geometries are being explored. The important point is surely that the design you came up with is original to you at the time, even though discovered separately by others. My own modular predilections have involved the explorations of "A" size rectangles, and their relationship (albeit approximate) with the regular pentagon. Shuzo Fujimoto and David Collier pointed me in these directions. It's worth experimenting also with knotted strips. The pentagonal knot so formed can be used to make a dodecahedron similar to those shown on page 80.

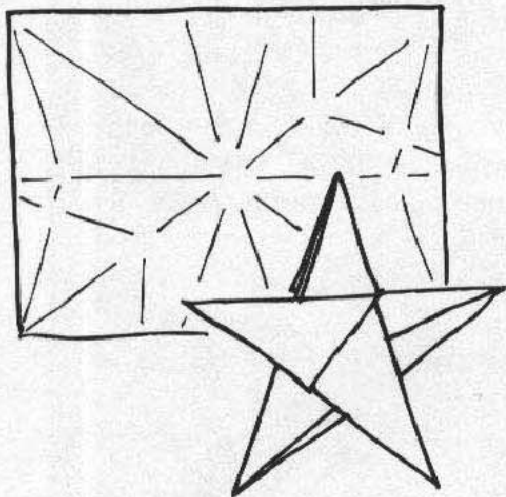

Shuzo Fujimoto's Pentangle

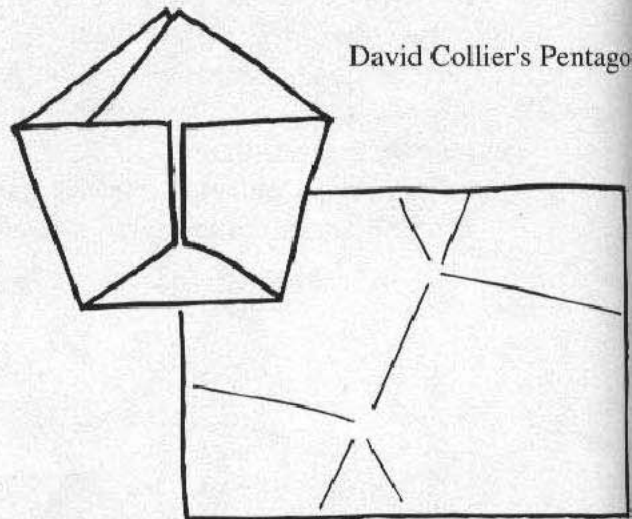

David Collier's Pentagon

Tomoko Fuse's work relies on color combination and decorative effect. I prefer to make constructions in plain colored paper, or using one color alone for all units. In this way the spectator is not tempted to admire decorative paper or the kaleidoscopic patterns created by many-colored constructions but will have to concentrate on the shapes of the design alone.

The Double Star Flexicube is a comparatively recent creation based on a plastic toy which has always fascinated me. You may find that a little glue is helpful here, though I have made several non-glued examples which work satisfactorily when handled carefully. Francis Ow devised a neat method of locking the units by folding alone, but I unfortunately received his suggestions after the diagrams for the design were complete.

I'd like to suggest further study of the polyhedron known as the Rhombic Dodecahedron, which to me is a shape of most pleasing proportion. H.M.Cundy and A.P.Rollett, in their book *Mathematical Models* (Oxford University Press 1961) suggest interesting ideas with a simple pyramid which can be combined to form three stellations of the Rhombic Dodecahedron as well as the figure itself. The shape of this pyramid looks easy to achieve from an "A" size rectangle, but I haven't yet succeeded in producing a satisfactory solution to build these polyhedra despite several attempts. Incidentally the first stellation of the Rhombic Dodecahedron is the same shape as the Star of the Double Star Flexicube.

The Rhombic Dodecahedron and its Three Stellations

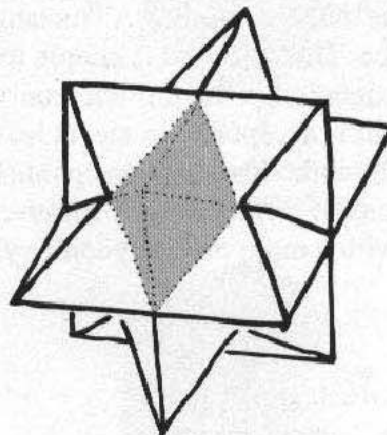
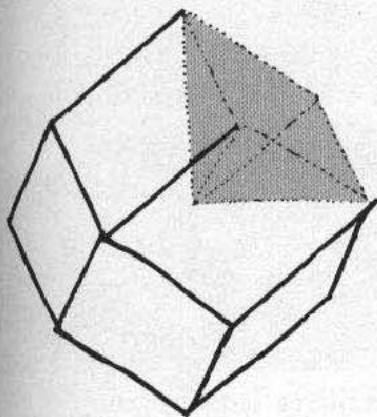

The dotted lines show the position of the pyramid which can be used to build all these polyhedra.

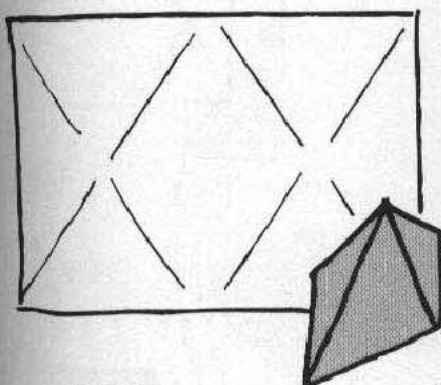
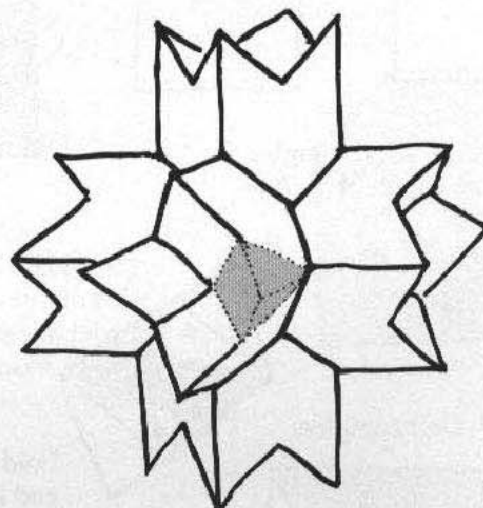
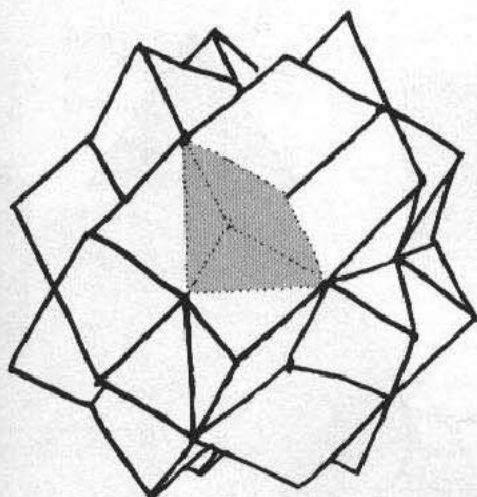

Geometry of the pyramid in relation to an A rectangle

Sunken Silver Cube and Icosahedron

A design which examines the relationship between the diagonal of the "A" rectangle and the cube. The unit used is simple to fold. The approximation in the Icosahedron development is acceptable to me, at least, although Kunihiko Kasahara has published an improvement from a slightly different rectangle with a more precise geometry.

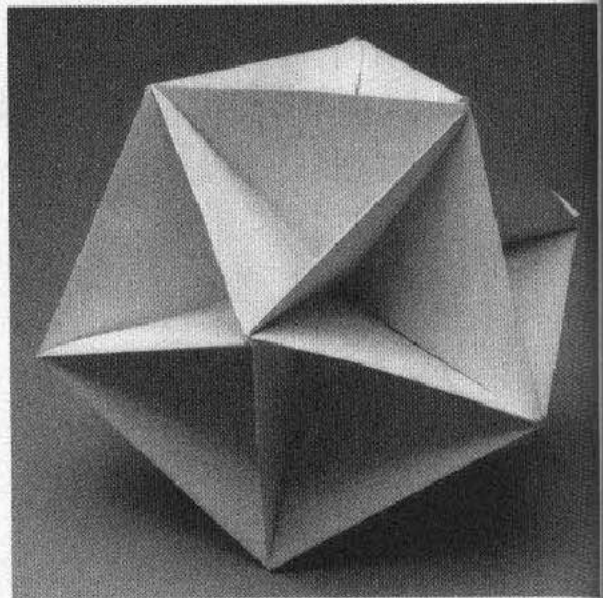

Sunken Silver Icosahedron

Cube

(12 units needed)

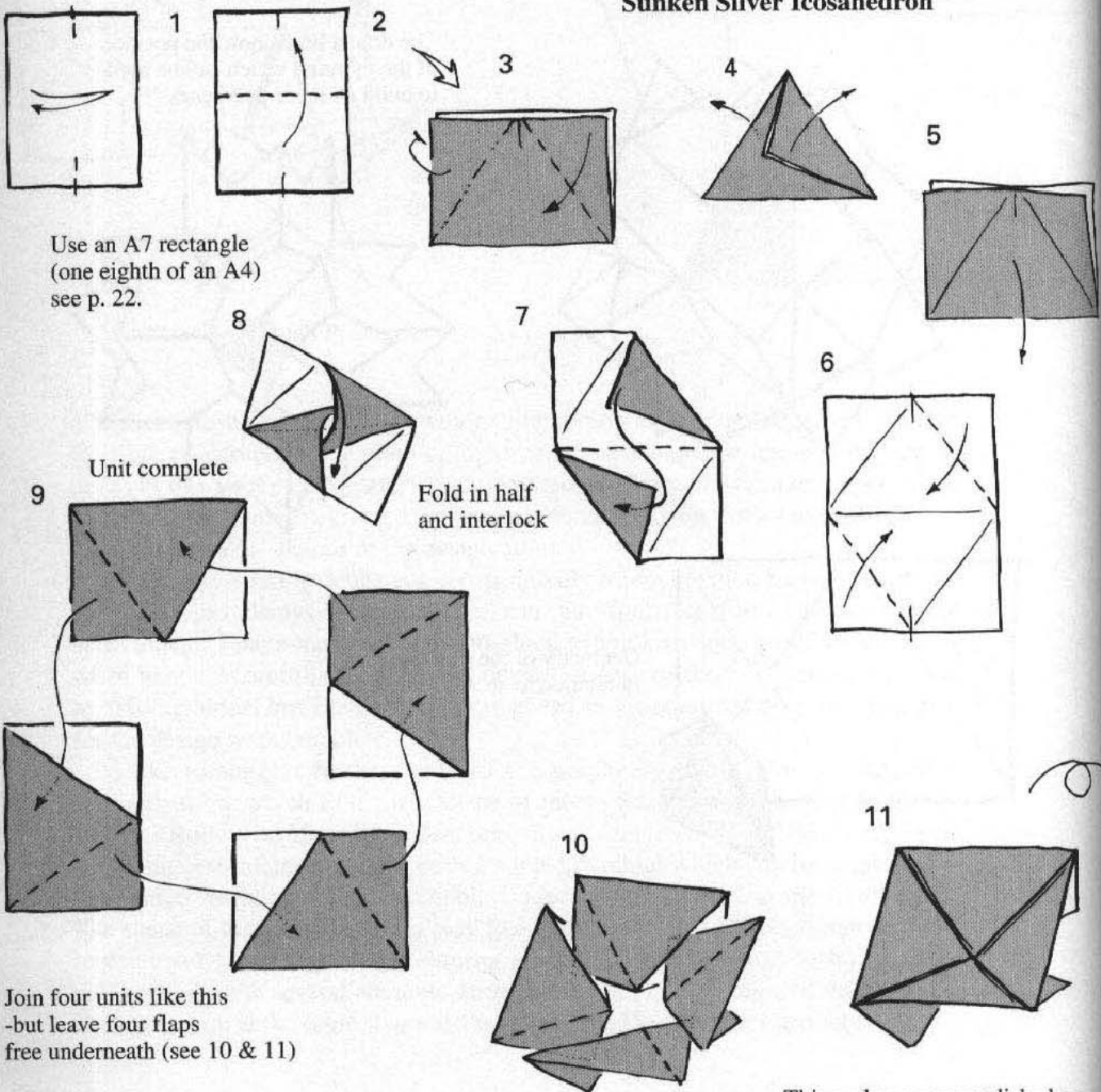

Icosahedron

(30 units)

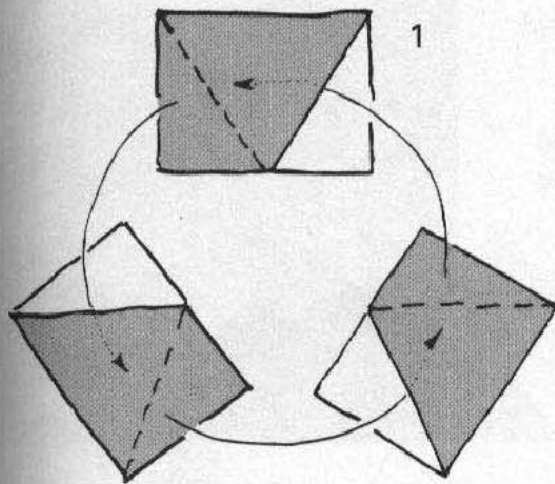

Join three units:
leave three flaps free
underneath.

2

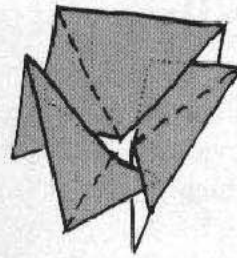

3

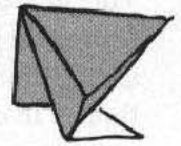

A triangular sunken
pyramid is formed

4

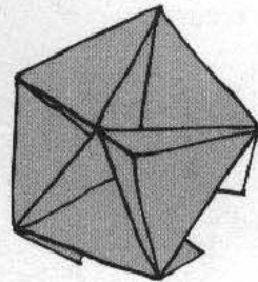

Add 7 more units
to make pentagonal
cluster of sunken
pyramids

5

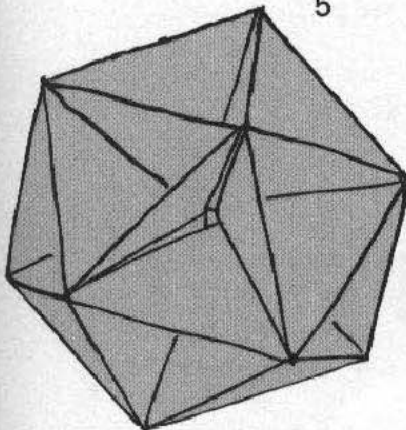

Continue building
the structure in
the same way, adding
20 more units to make
the icosahedron.

There is a small inaccuracy
in the geometry of the units
which makes a small hole at the
centre of the sunken pyramids.
Nevertheless, the construction
is quite stable.

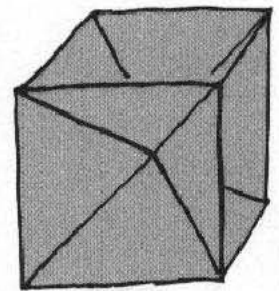

12

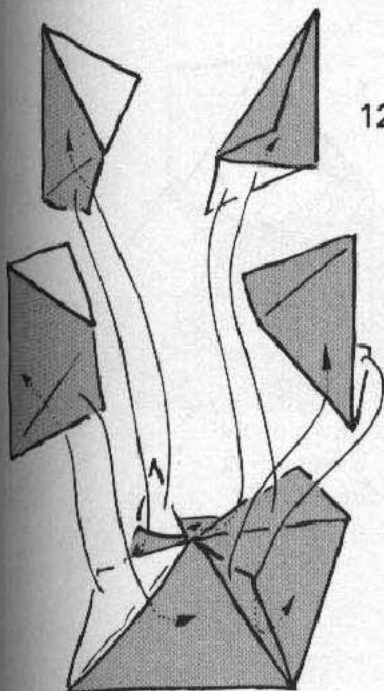

Turn the dish shape over, then
add four more units inserting
each flap into its appropriate
pocket

13

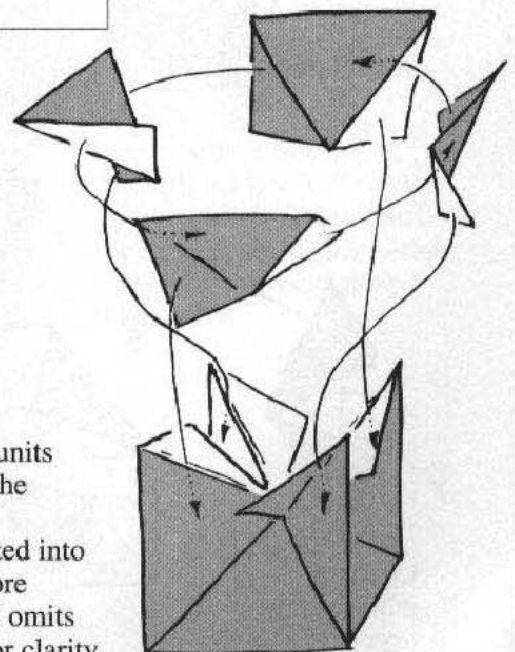

A further four units
will complete the
Sunken Cube.
Flaps are inserted into
pockets as before
but diagram 13 omits
some arrows for clarity.

Sunken Silver Star

This unit and the constructions are related to those shown on the previous pages. The unit has an identical triangle added which protrudes from the completed figure. In creating the design, I was influenced by a pointed star design by Tomoko Fuse. I have tried also to make another longer-pointed variation on the same theme, but the unit in this case proved bulky and the locking was less secure.

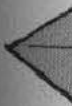
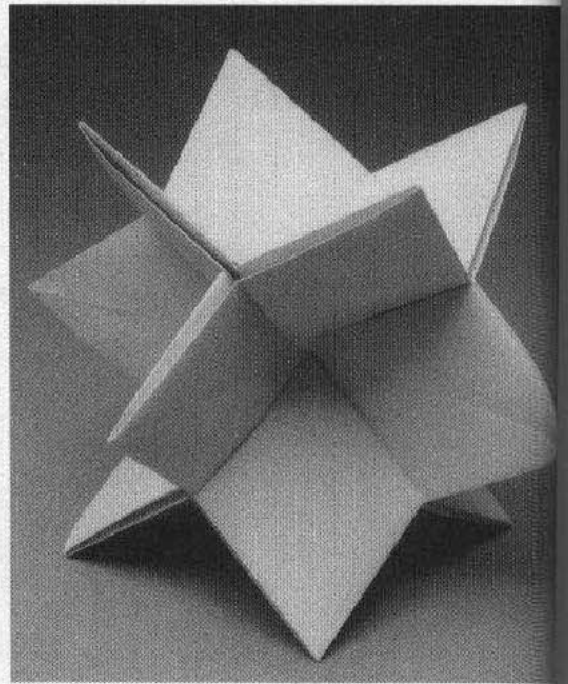

14

1

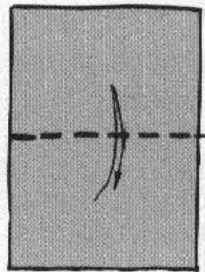

Use an A6
(A4 divided
into quarters)
see p.22.

2

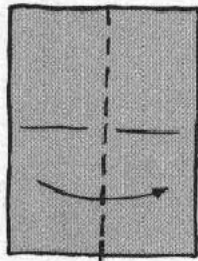

3

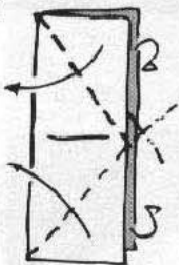

4

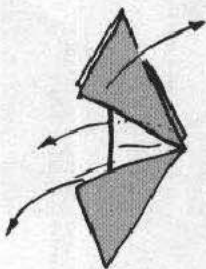

Open up
unfolding the
upper right &
lower left corners

5

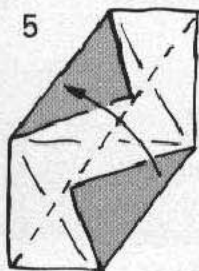

6

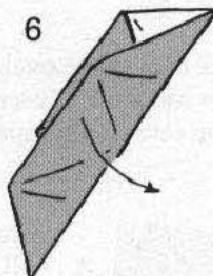

7

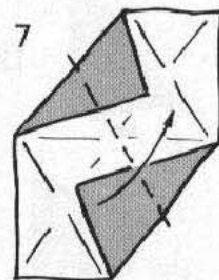

Fold in half,
lining up the
lower left &
upper right
quarter diagonals

8

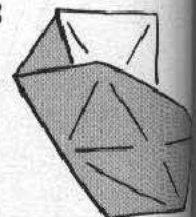

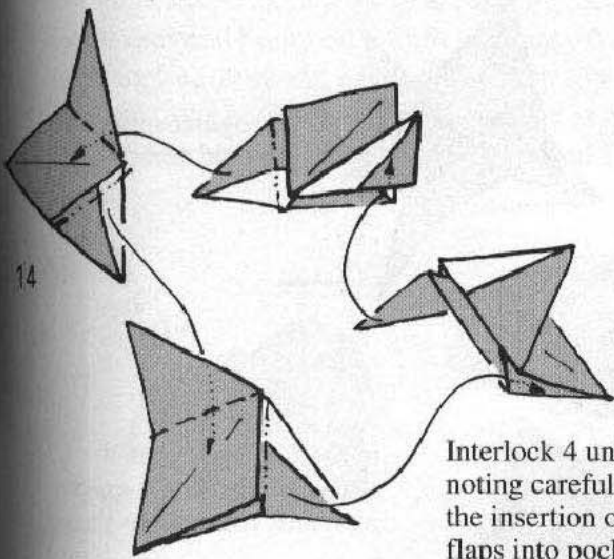

Interlock 4 units noting carefully the insertion of flaps into pockets

15

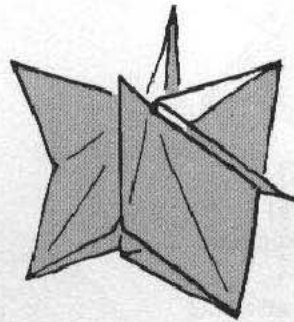

4 units connected. Now add 8 more similarly to form 12 pointed sunken star

13

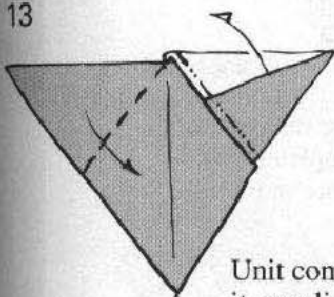

Unit complete: it now lies completely flat

12

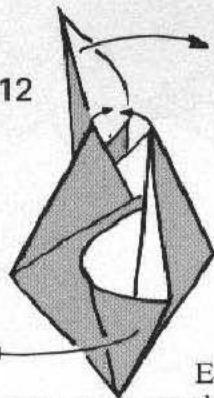

Ensure that the same thing is happening front and back

11

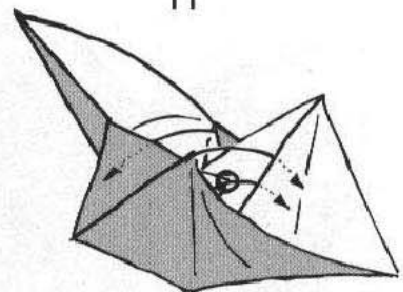

Interlock the layers carefully within. The small right-angled corner (circled) should slide inside the pocket without being accidentally folded over.

9

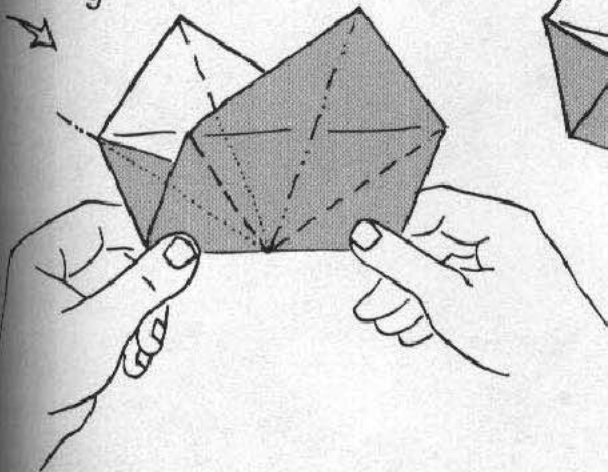

10

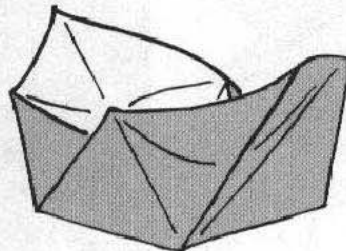

Hold the unit like this, and raise your hands upwards and together to collapse the unit along existing creases.

30 Point Sunken Star

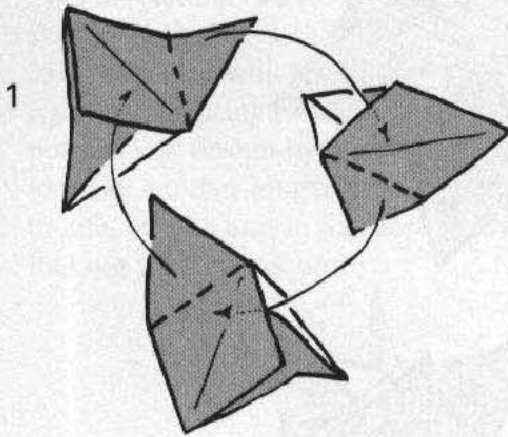

1

Connect 3 units to form triangular sunken pyramid. Pay attention to inserting the flaps of each unit into the correct pocket of the next. (see step 14 of the 12 point sunken star)

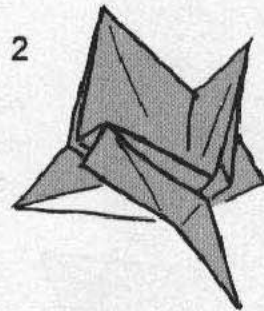

2

Triangular sunken pyramid complete.

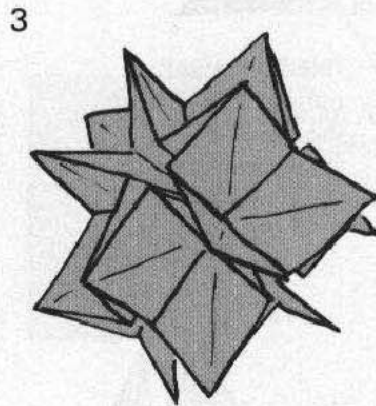

3

Add 12 more units to form this pentagonal shape, comprising 5 sunken pyramids combined

Continue adding further units to build the completed star (30 units in all are required)

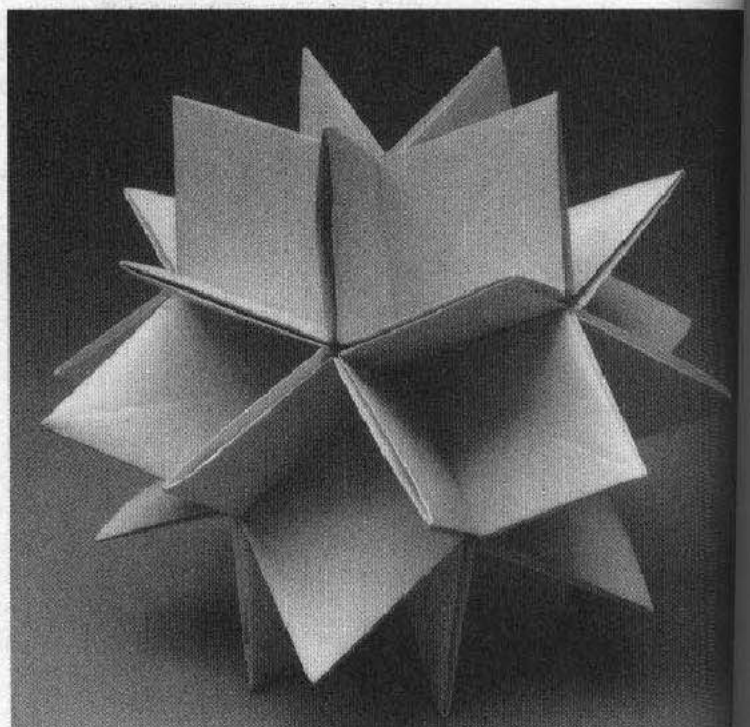
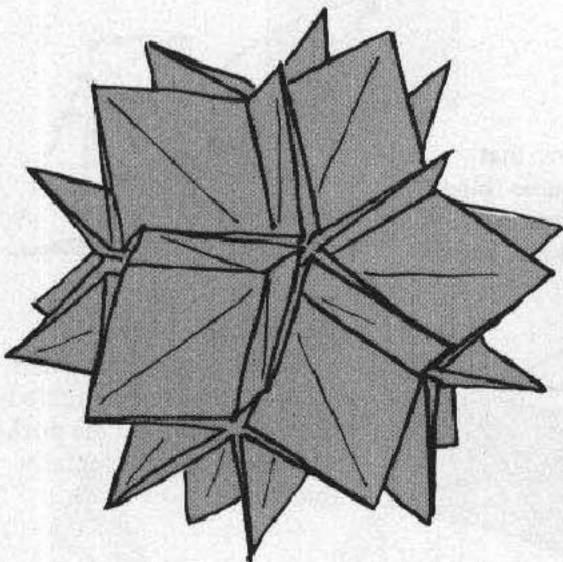

Dimpled Silver Dodecahedron

Inspired by Kunihiko Kasahara's similar design appearing in *Origami Omnibus*. I wanted to make the same shape from a more accessible rectangle. I spent several hours on a train journey experimenting with angles, throwing away many partially completed constructions in the process. Some care is needed in the folding to avoid bulkiness on the exposed folded edges.

Valley to meet imaginary line connecting corner to 1/4 mark

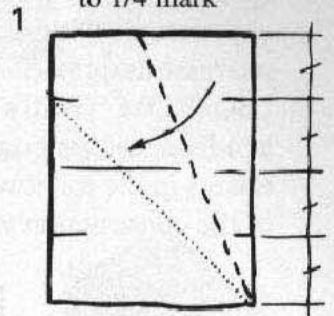

A6 rectangle (one quarter of A4) see p. 22.

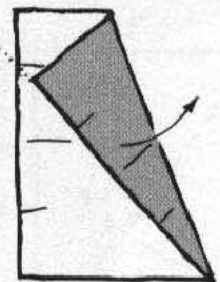

Open, and repeat on each corner

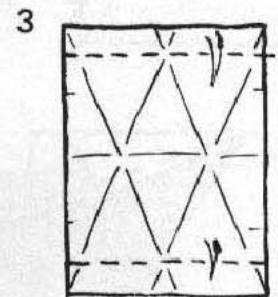

4

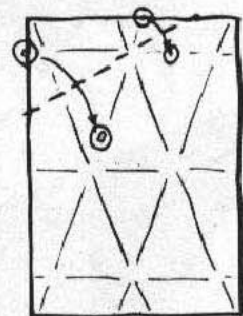

Valley fold carefully noting the reference points

Repeat 4 three more times

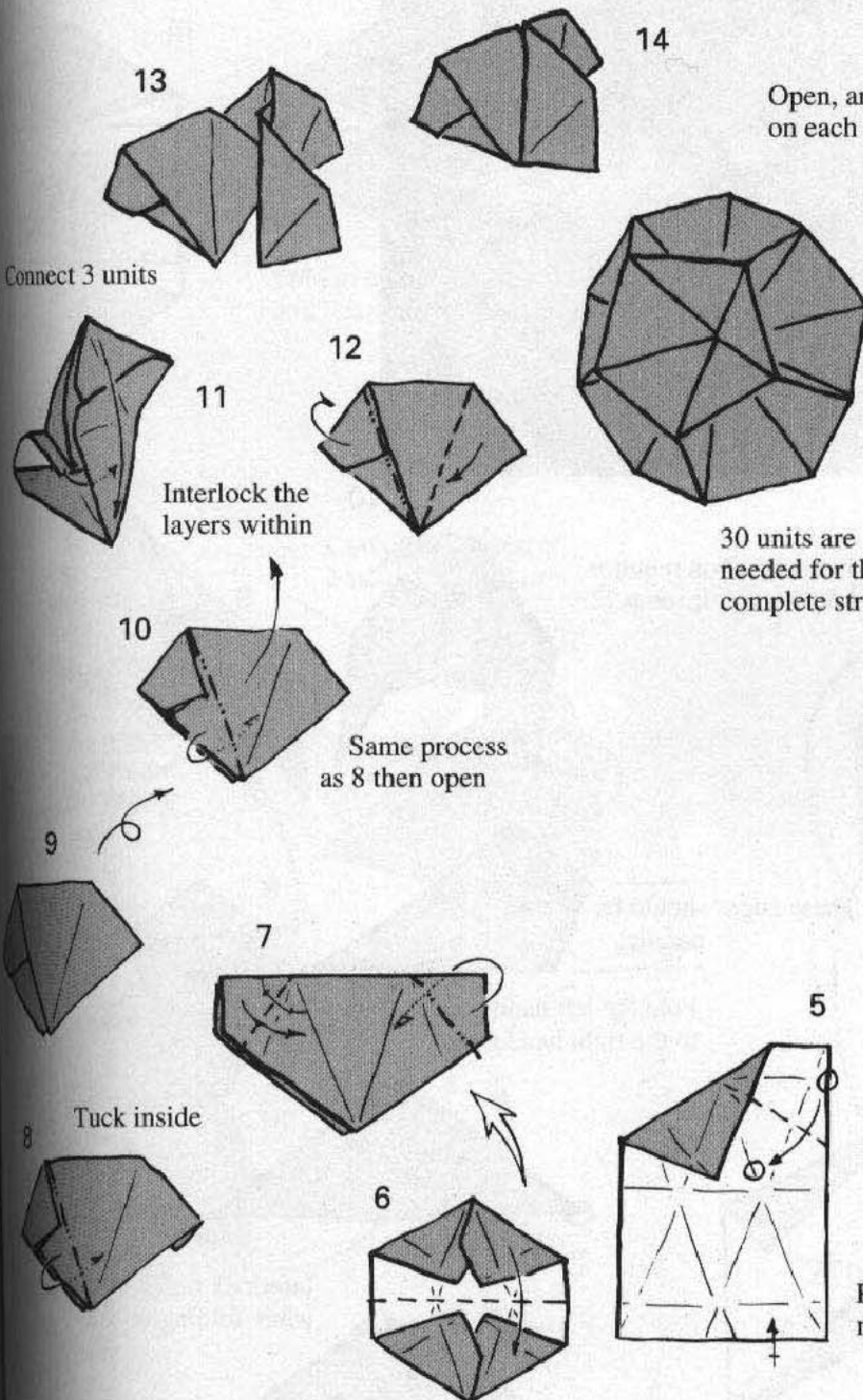

Connect 3 units

Interlock the layers within

Same process as 8 then open

Tuck inside

30 units are needed for the complete structure

Silver Dodecahedra

A variation of the Pentagonal Envelope (page 45) and a simpler larger alternative were early experiments with A rectangles and pentagon-related modular designs. The smaller version was dubbed "BOTTOM" (Brill's Own Toilet Tissue Origami Module) at a BOS convention, when we found that some paper towels in the toilet were A size, and a fragile example of the construction was possible!

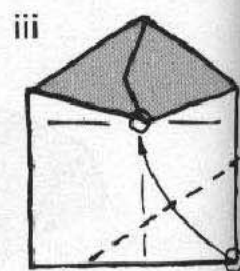
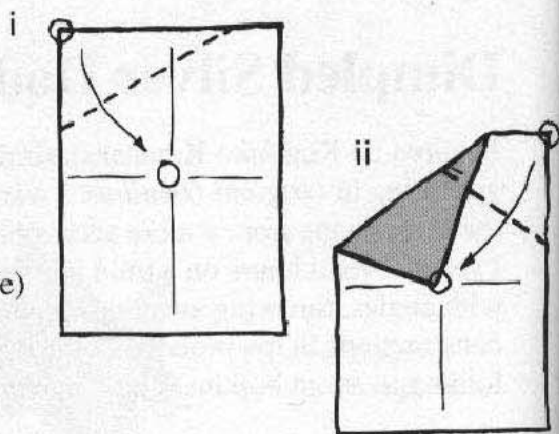

vii

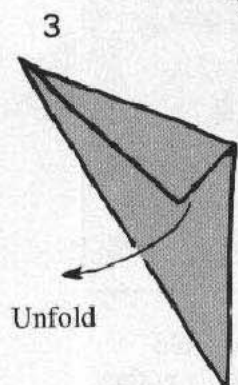
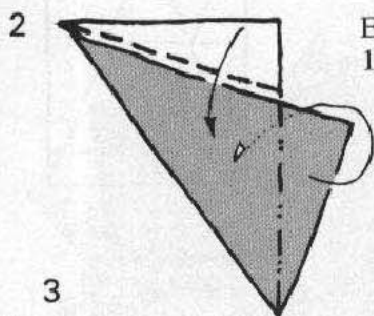
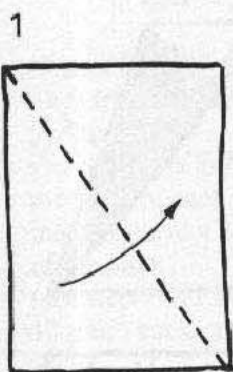
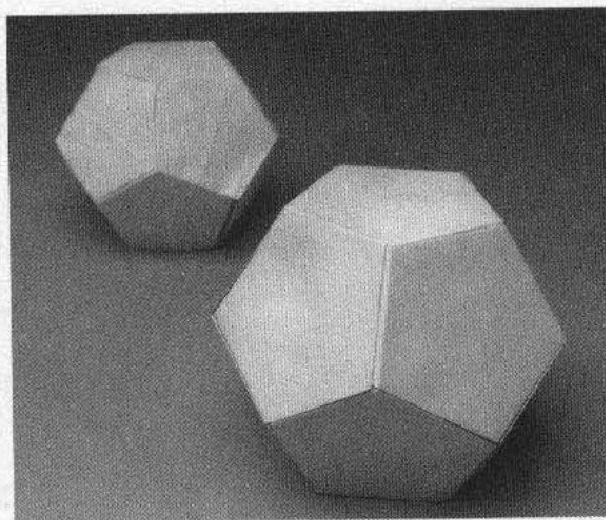

Unfold

Each construction requires 12 A6 rectangles; see p.22.

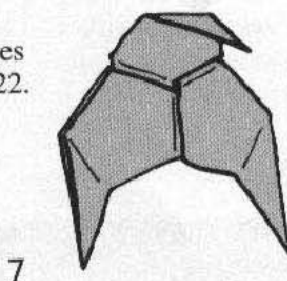

7

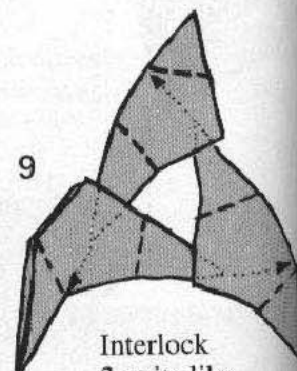

9

Interlock 3 units like this

These edges should be parallel

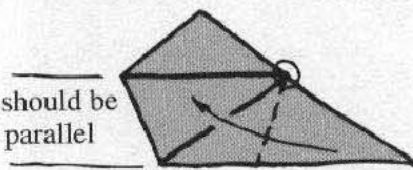

Fold the left hand corner to the right hand edge

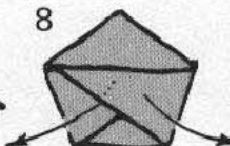

8

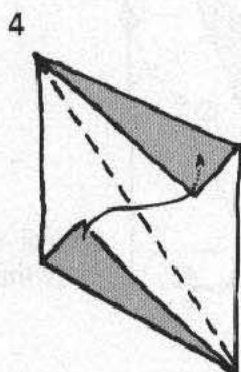

4

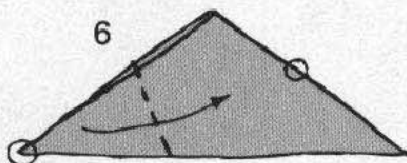

6

Interlock the two narrow flaps while folding in half

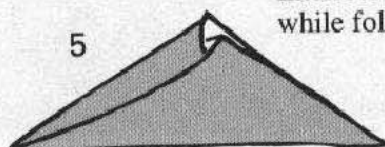

5

11

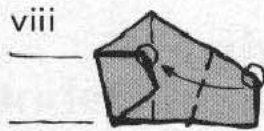
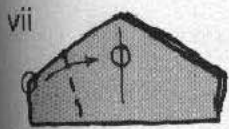

similar to 7

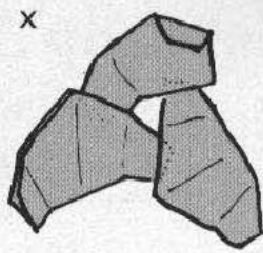

3 units connected
-complete as for the larger construction

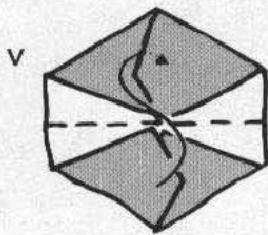
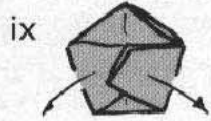
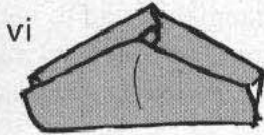

Fold in half
and interlock the layers

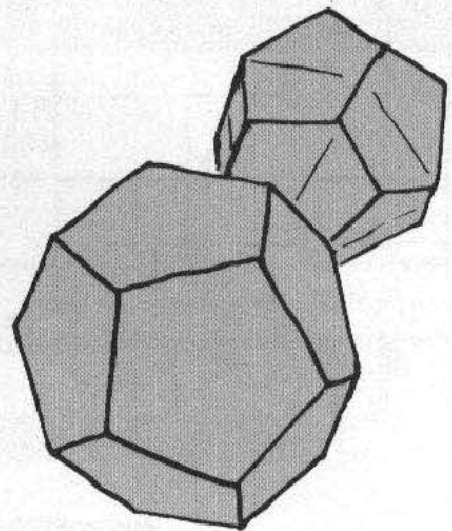
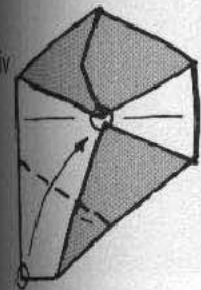

Connect 3 groups of
3 units.

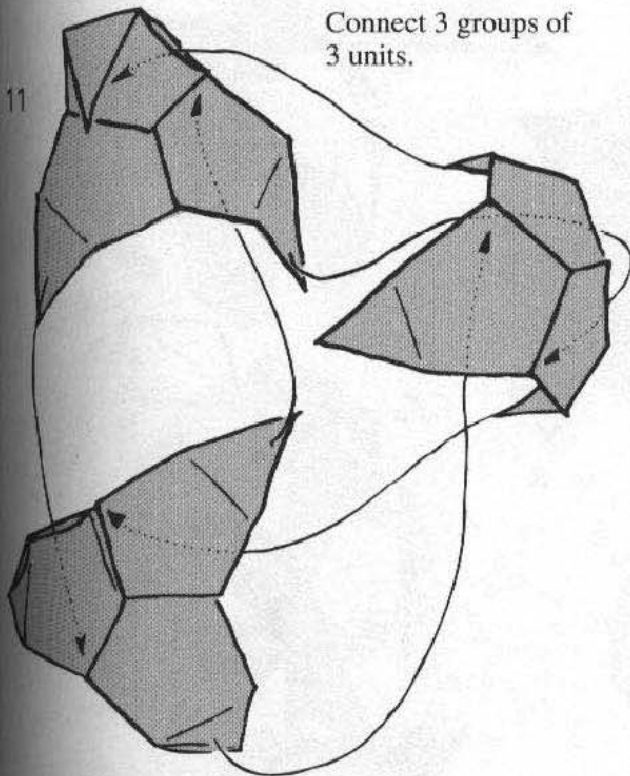

12

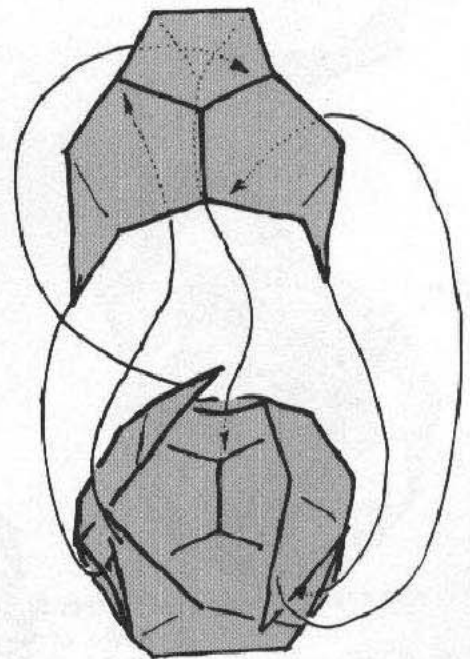

Add a final cluster of 3 units
to complete the larger dodecahedron.

ow flaps

“Woven” Strip Dodecahedron

Starting sheet size A6; see p. 22.
Divide into thirds

1 both ways as shown

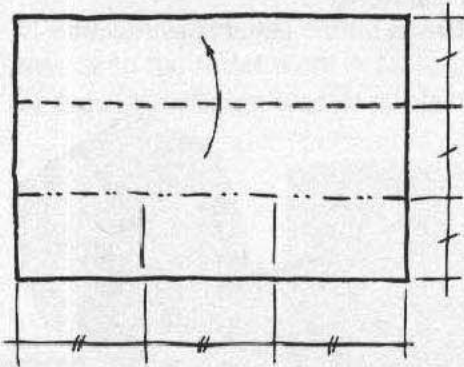

Fold diagonal on each end

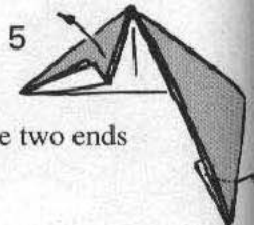
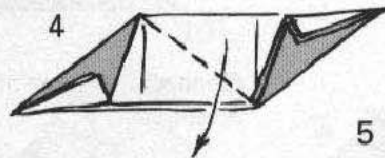
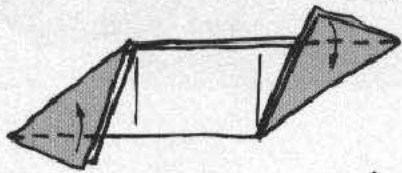
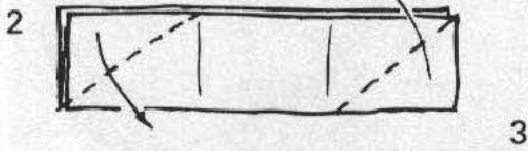

Unfold the two ends

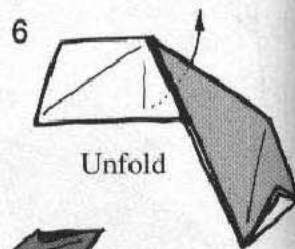

Unfold

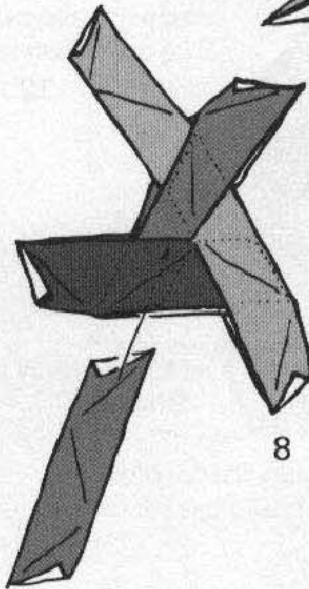

8

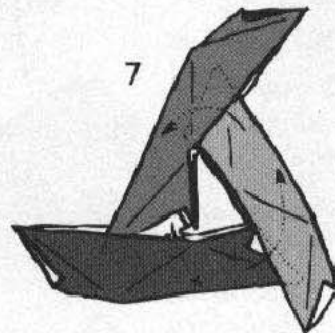

Interlock three units like this

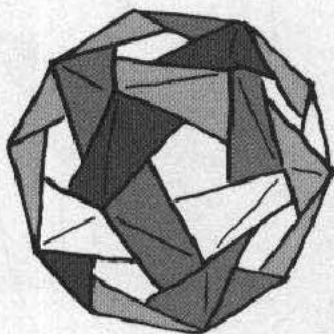

Add further units as shown, continuing with units of 6 different colours to complete the construction

30 units needed in all

This was inspired by the marvellous dodecahedron unit of Robert Neale. I was anxious that the finished design should seem to be made from woven strips, which would be an improvement on Neale's version where the units were slightly offset. Once again the A rectangle proved to be the solution to the problem with the diagonal of the rectangle playing an important part in the design process.

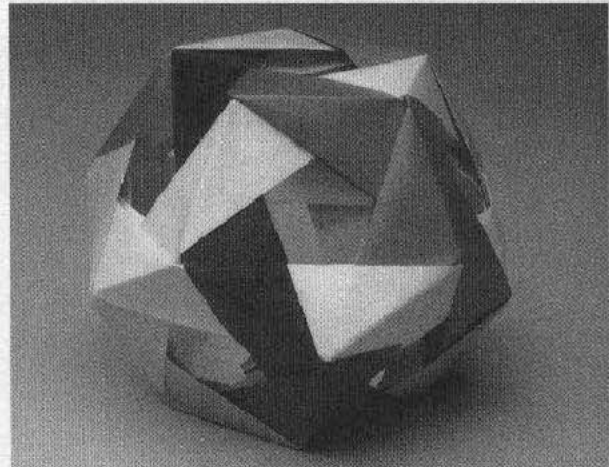

True

A logical that I could were woven design was finished



Fold diagonal starting from raw corner

Start by connecting 3 strips. This is made easier by using paperclips hold them

A fourth strip now be added

True Woven Dodecahedron

A logical development of the previous design: I realised that I could make a dodecahedron from strips which really were woven together. I am particularly pleased with the design which uses all of an A4 sheet with no waste. The finished ball is very strong.

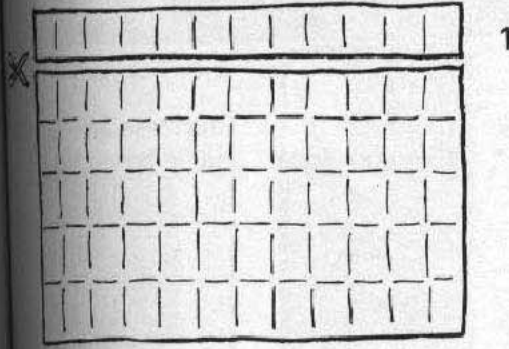
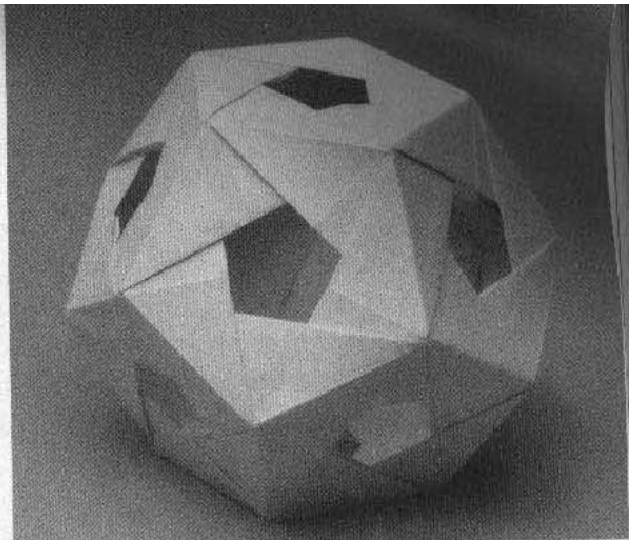

1 Use an A4 sheet; see p. 22. Divide the short side into 1/6ths, and the long side into 1/12ths. Then cut into 6 equal strips. First cut shown here.

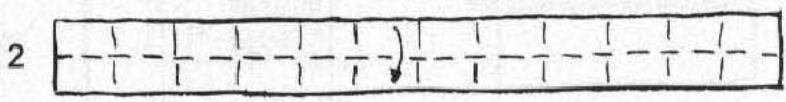

3 Fold diagonals along the strip starting and ending at the double lines

In the finished construction each strip is formed into a ring interlocked by inserting one end into the other, overlapping 2 divisions. The rings are not formed until step 7

Interlocking divisions

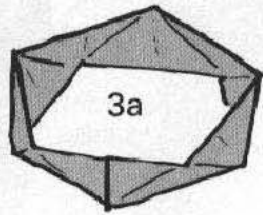
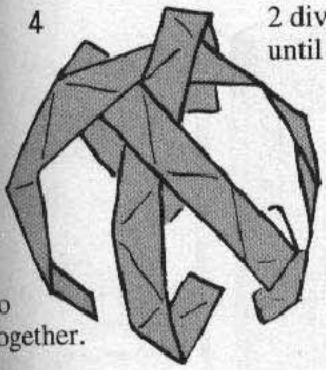

4 Start by connecting strips. This is made easier by using paperclips to hold them together.

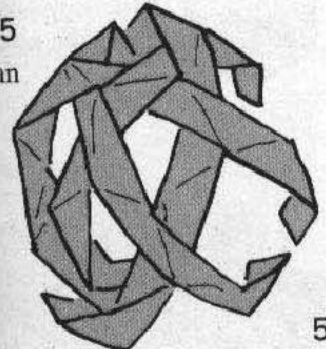

5 A fourth strip can now be added

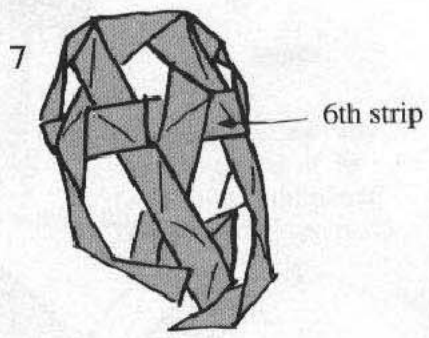

Where 3 strips cross this pattern is formed

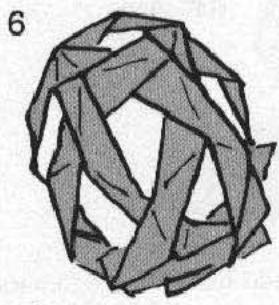
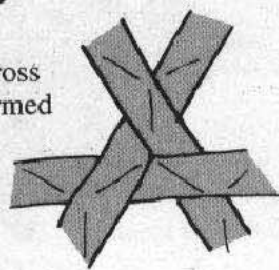

6 5 strips together. Note the pentagon formed at the top.

7 6th strip added This should be interlocked as described above. Finish the construction by weaving the strips together as shown in 5a and interlocking the ends of each strip. Remove any paperclips you have used.

Stellated Dodecahedron

Borrowing the geometry of a well-known method of cutting a pentagon from a square, I found that this rather clumsy design is possible. Some precision is required in steps 4&7 to ensure that all the layers are folded exactly together. The points of the star are not as sharp as I would like.

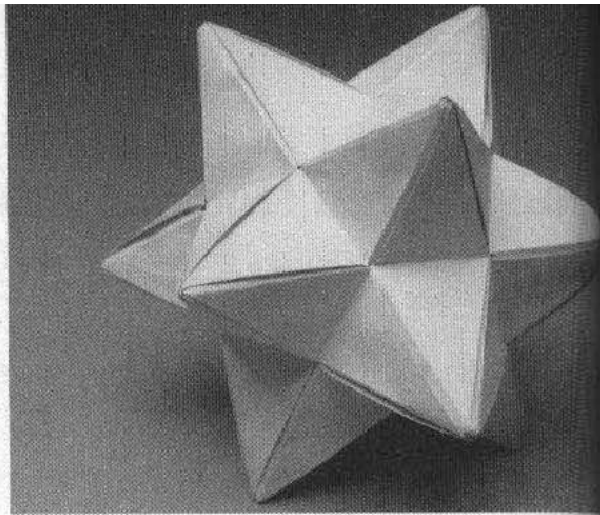

Stair

These c...
but the...
exposed...
not hold

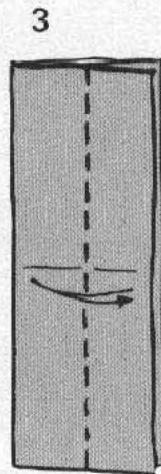
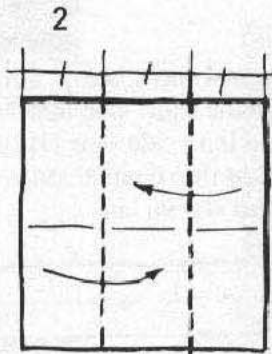
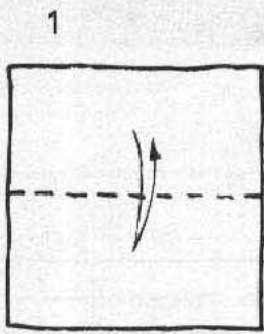

Precrease the single layer only

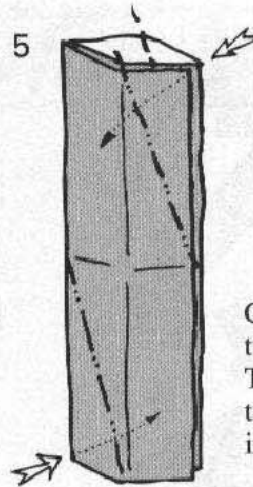
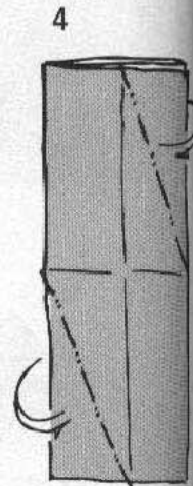

Gently open to a tube shape. Then reverse fold two opposite corners into the tube.

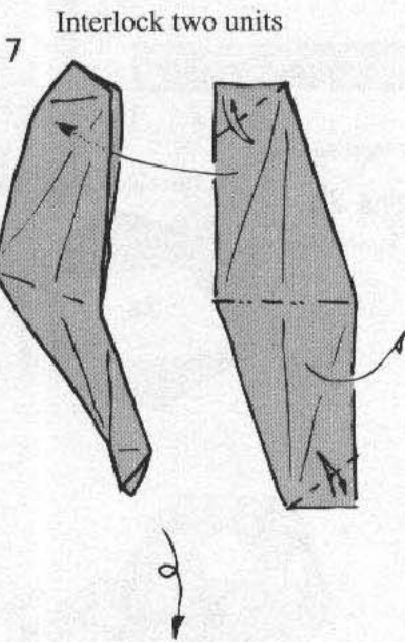

Interlock two units

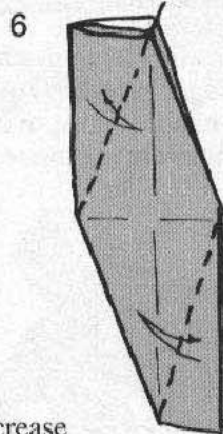

Precrease



Collapse



Tuck corners underneath

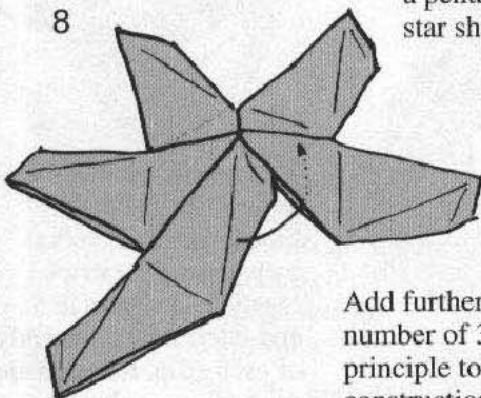

Add further units to make a pentagonal star shape.

Add further units to a total number of 30 on the same principle to complete the construction.

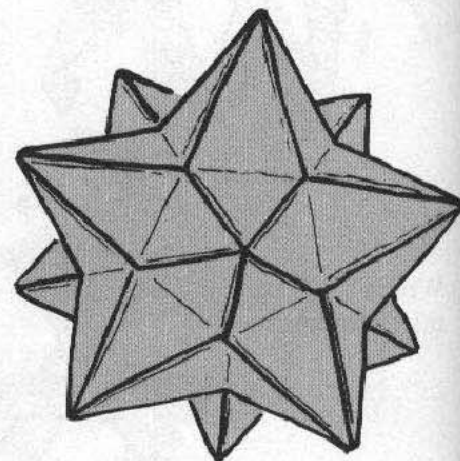

Stained Glass Balls

These designs employ similar geometry to the previous star but the coloured side of the paper is placed inside and then exposed to give the "stained-glass" impression. The units do not hold together well until the final stages of the construction.

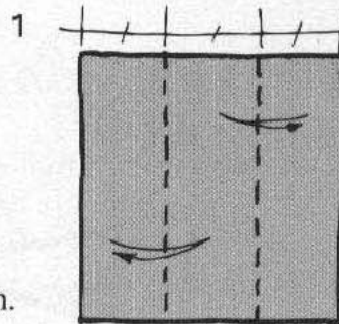

Divide into 1/3rds, and then 1/6ths.

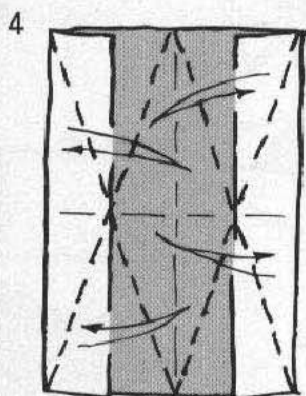
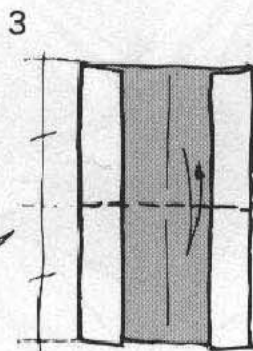
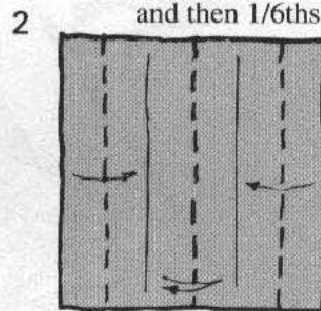

Precrease 4 diagonals

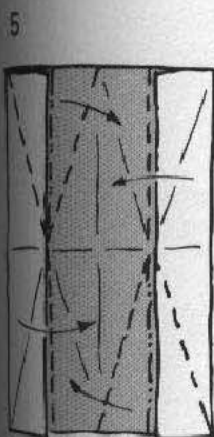

Collapse



Tuck corners underneath

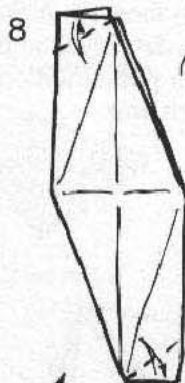
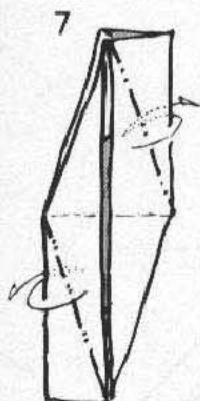

Open central edges to form a 3D shape

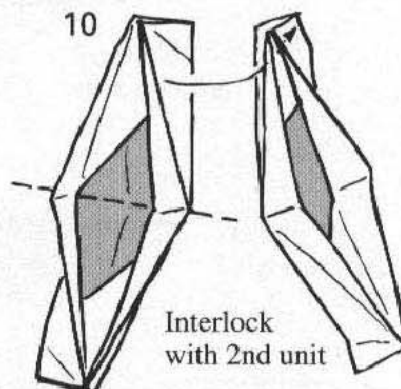

Interlock with 2nd unit

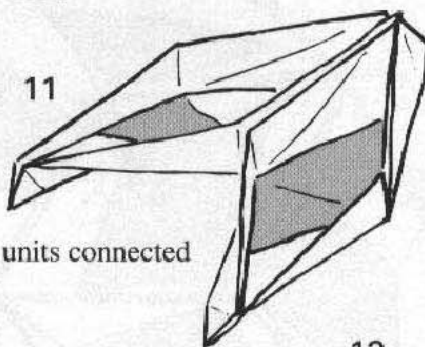

2 units connected

Continue adding further units to a total of 30 to form the completed construction...see p. 86.

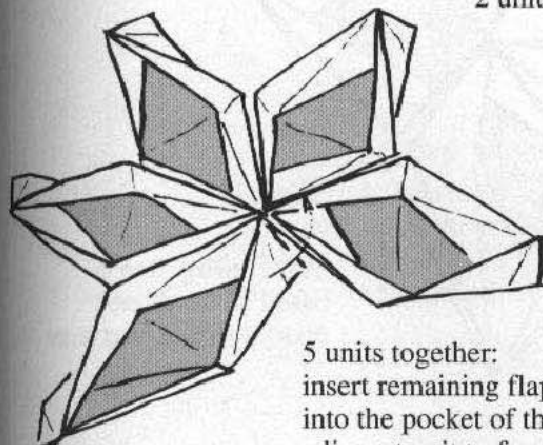

5 units together: insert remaining flap into the pocket of the adjacent unit to form a 3D star shape

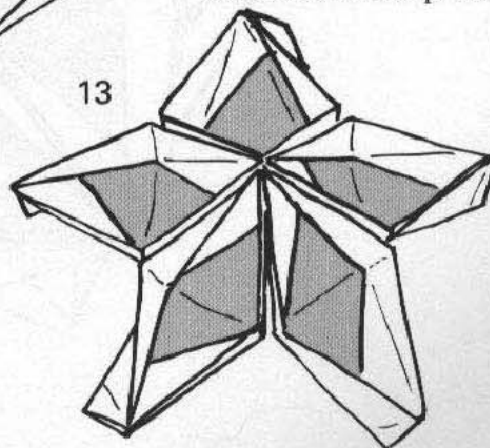

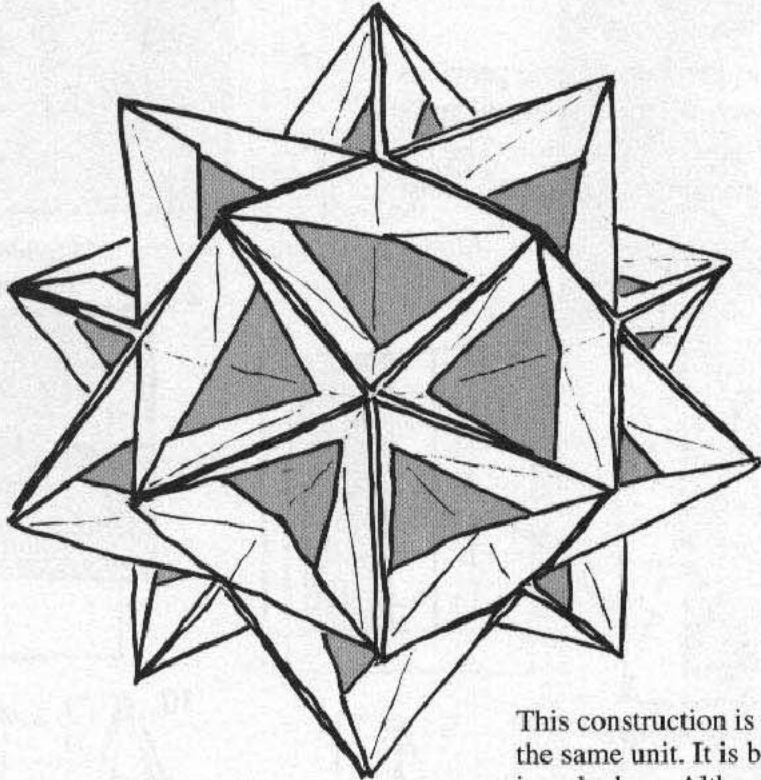

This construction is also possible using the same unit. It is based on a stellated icosahedron. Although stable, it is less satisfactory than the other construction as it puts strain on the joints between each unit

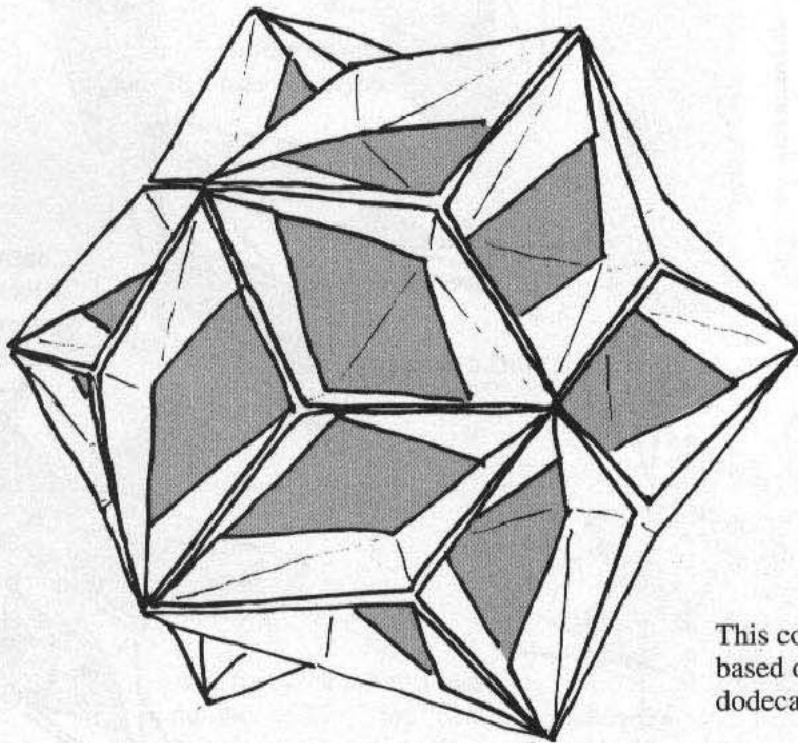

This construction is based on a stellated dodecahedron (see page 84)

Start with an
A6 rectangle; see p. 22.

Spiky Star

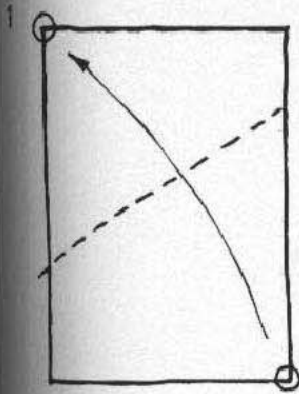

Fold in half
twice as shown

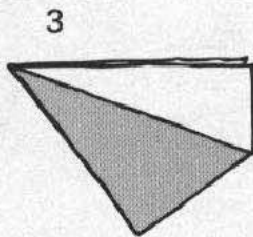
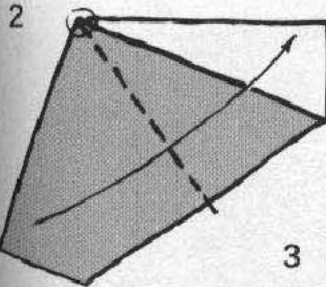

Open out

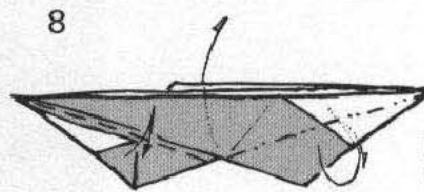
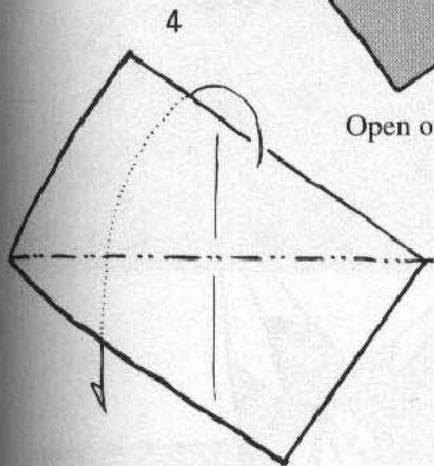

Narrow twice

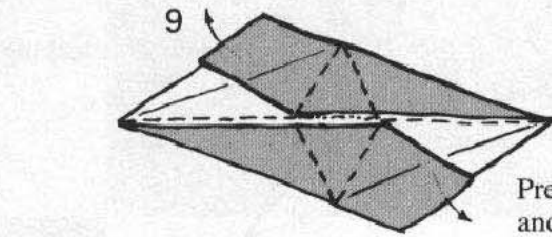
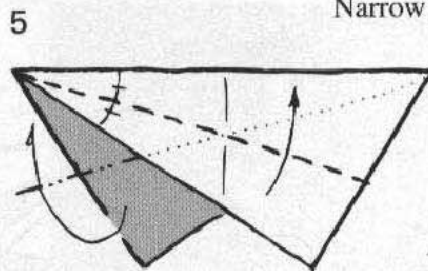

Precrease
and open short
flaps from behind

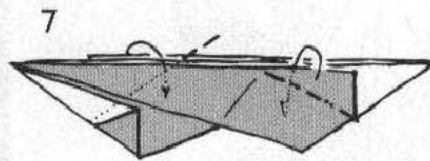

Precrease
then open up

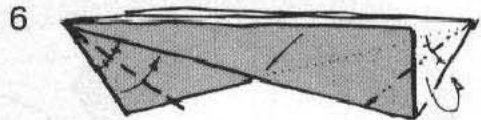

Tuck in
2 right-angled
corners



Using the "A" rectangle again, I wanted to make a really pointed star. I am fond of the result, but there is a small inaccuracy in the geometry of the unit. This is insignificant in practical terms but offends my sense of perfection a little!

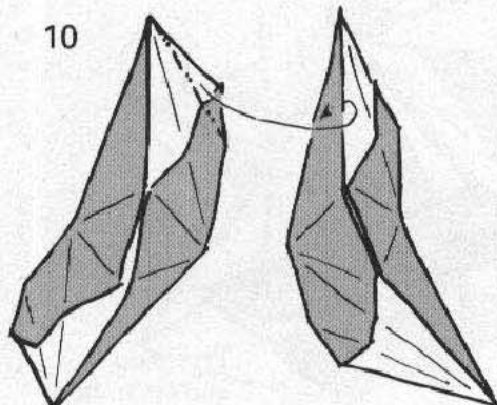

10

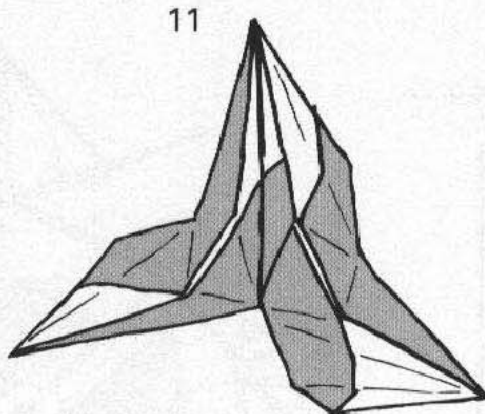

11

Method of locking
two units

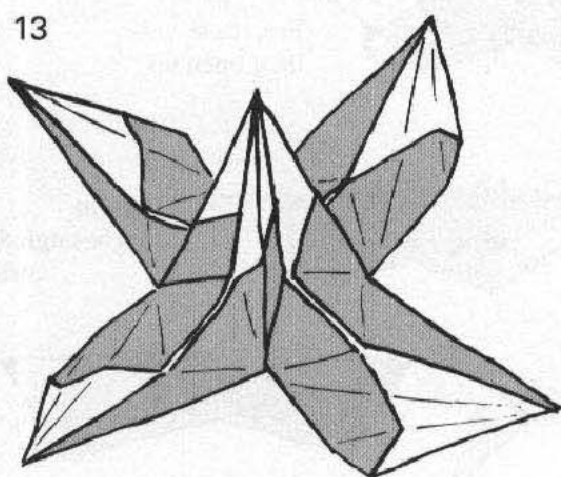

13

4 units joined

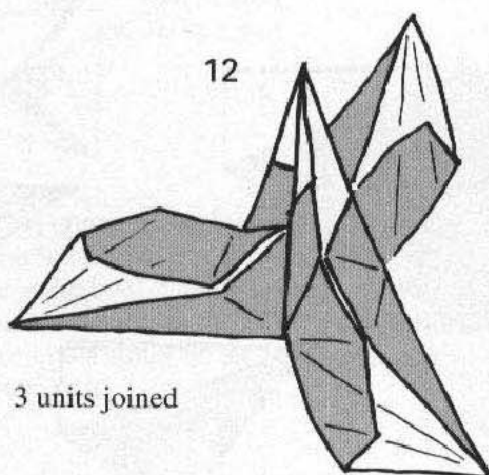

12

3 units joined

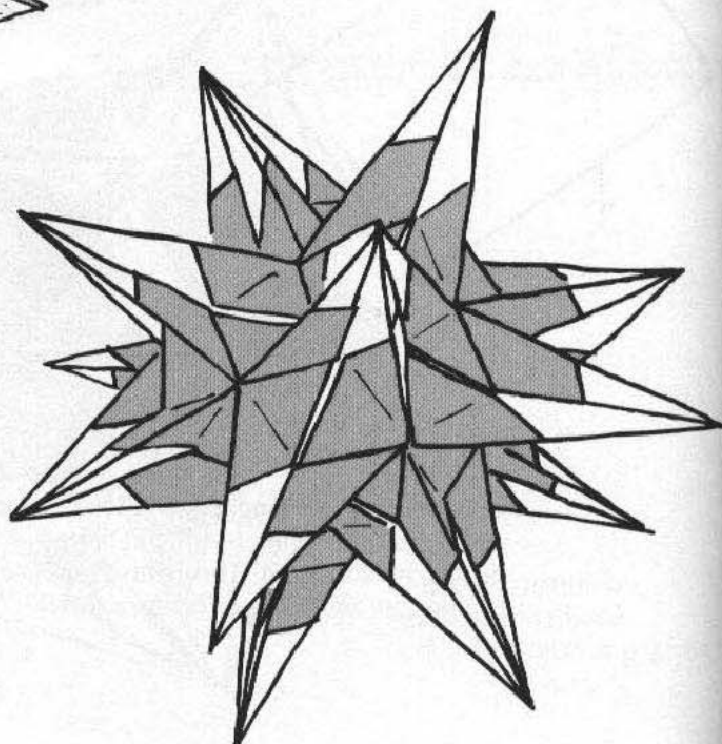

This construction is based
on a cuboctahedron and is
made from a combination of
3 and 4 units joined (see
above).
24 units are required in all.

Other constructions are possible.

Stained Glass Ball

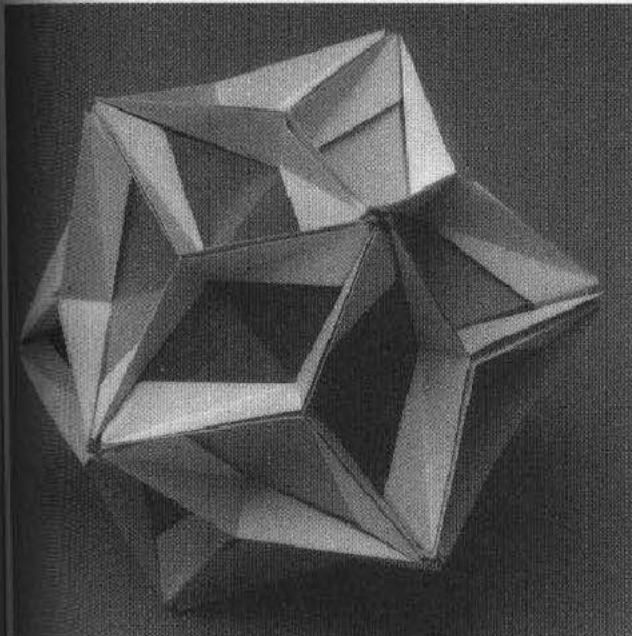
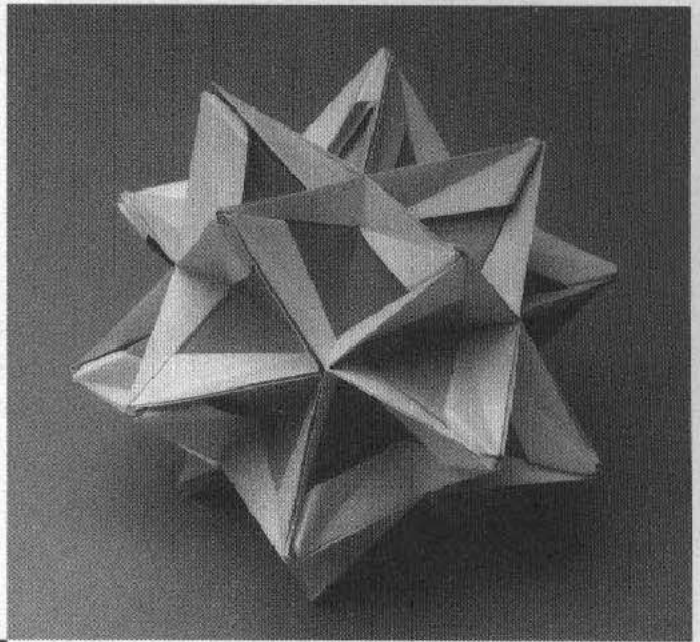

Stained Glass Ball

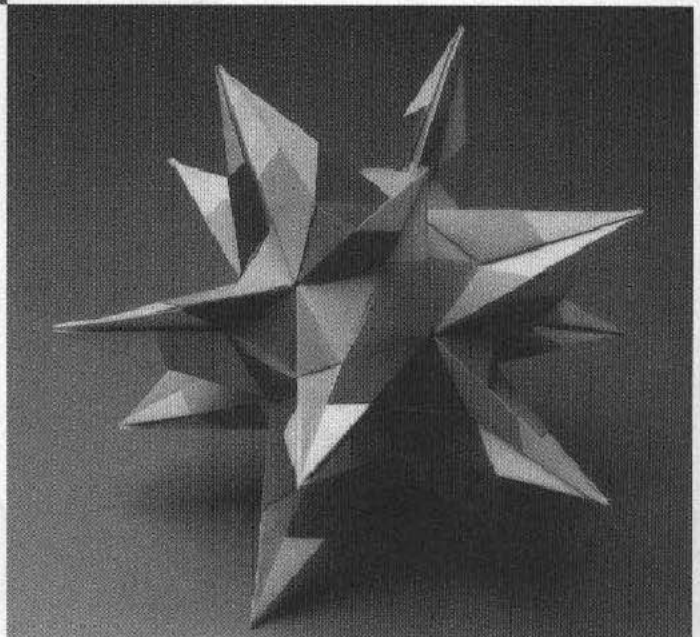

Spiky Star

Double Cube

I was fascinated to see this geometric shape in one of M C Escher's prints (which seem to be a constant source of inspiration for paper-folders), and I was determined to make an origami version. I also made a hollow "frame" variation, but this is not so elegant. There exists a single sheet double cube of similar appearance, by American folder Kenneth Kawamura.

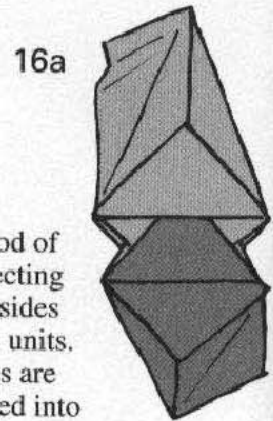

16a
Method of connecting short sides of the units. 2 flaps are inserted into 2 pockets.

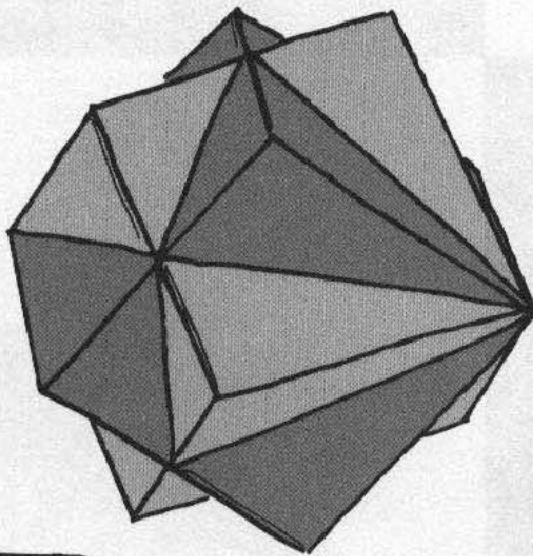

16

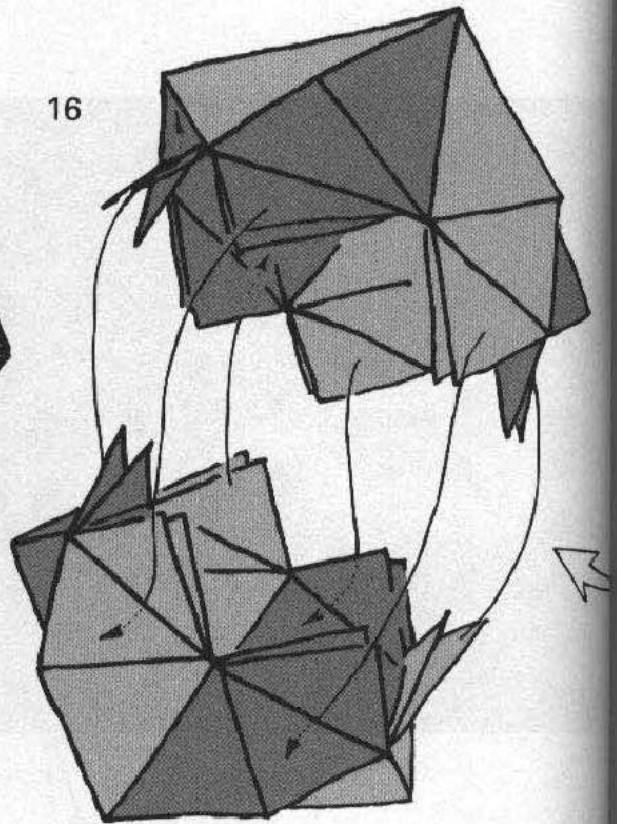

Connect the two halves of the construction to complete.

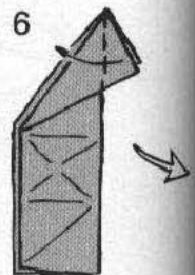
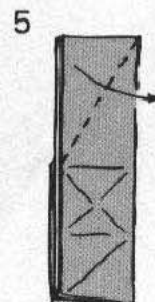
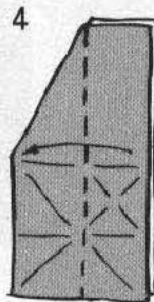
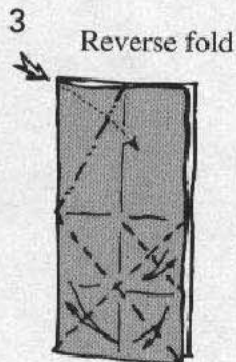
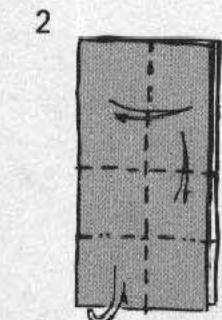
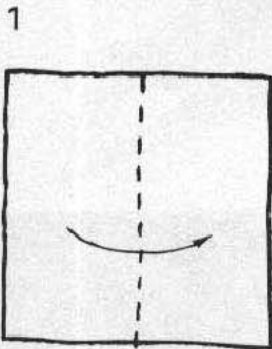

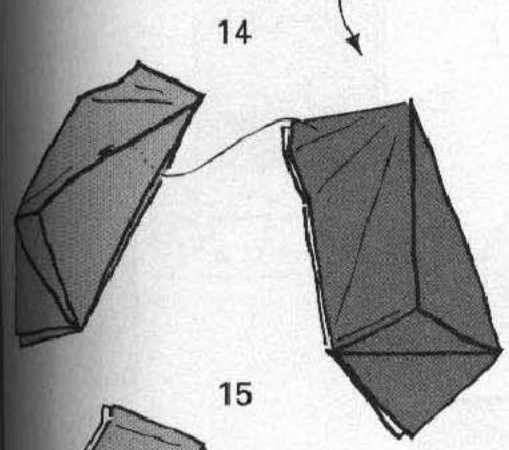
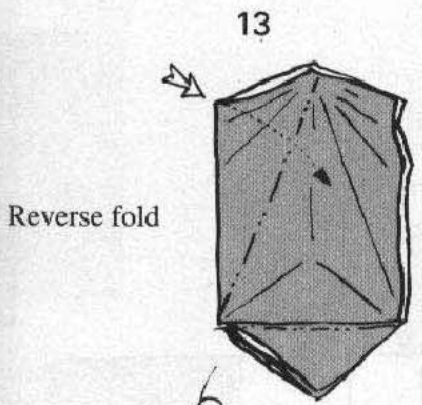
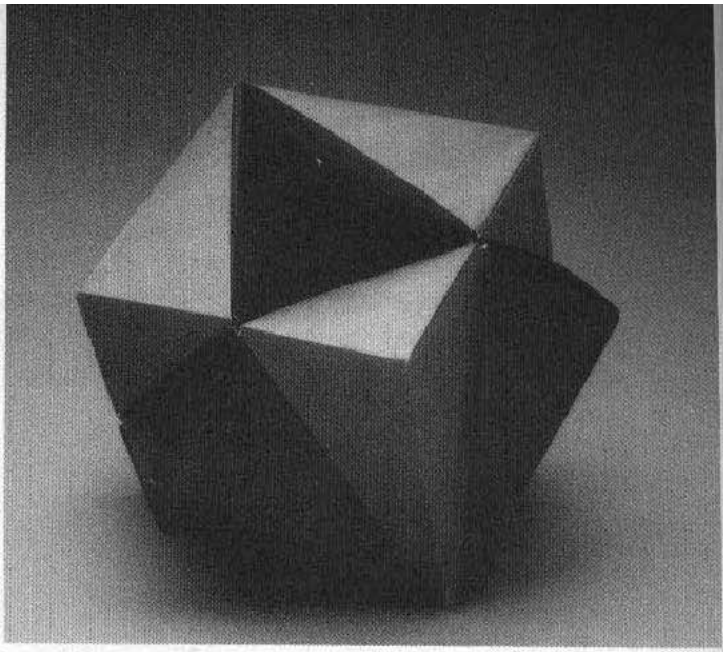

Method of linking 2 units

Continue adding further units of alternate colours to build 2 circles of 6 units each. (see 16)

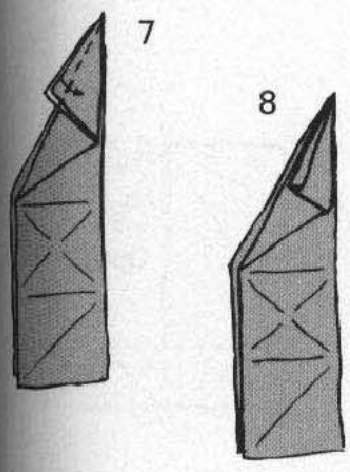

Open out completely

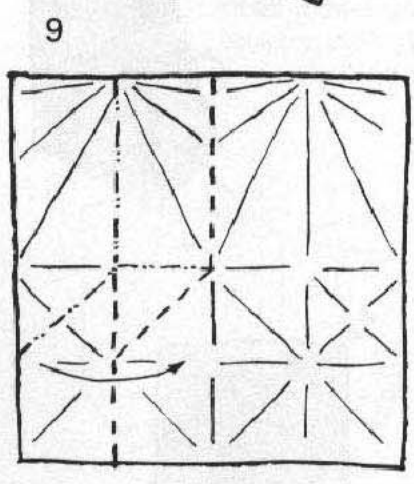

Move in progress

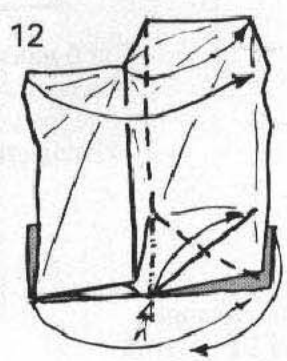

Carefully fold in half inserting the left hand side into the right. The coloured corners at the bottom will move to meet each other.

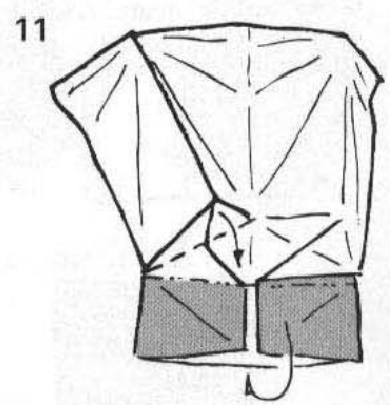
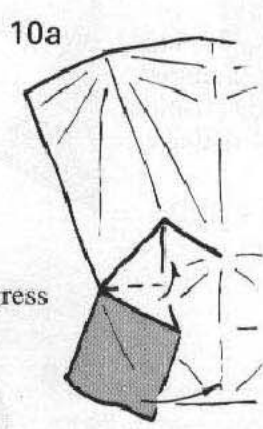

Mountain behind

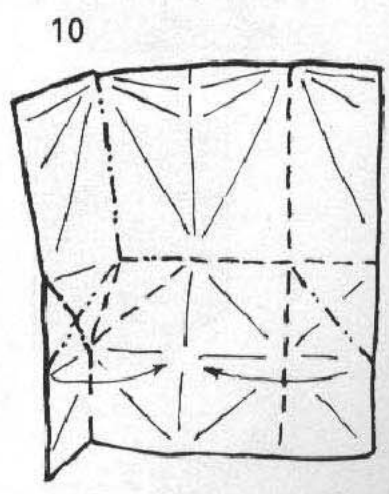

Form a convex pyramid on the left

Venetian Double Cube

So-called because this variation of the Double Cube emerged during a hot, mosquito-filled, sleepless night in Venice, where I spent a brief holiday in 1985. Curiously 4 different modules are required, unlike the simpler design which makes use of 12 identical units.

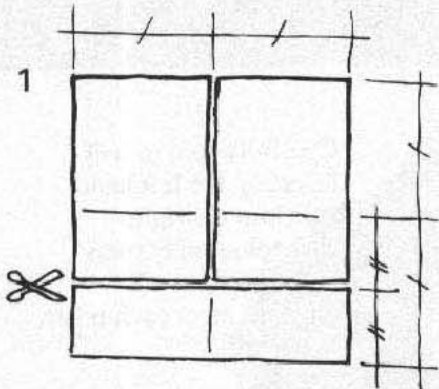

Use this method to cut 3x2 rectangles from a square: discard the narrow strip at the bottom

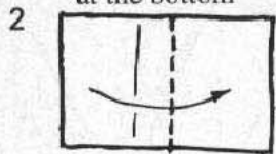

6 rectangles like this are required. Note the position of the existing crease

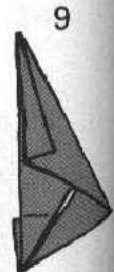
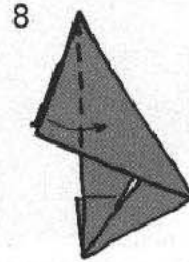
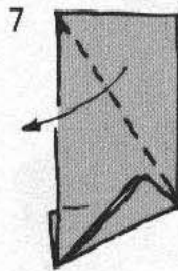
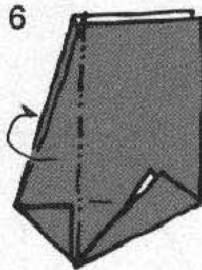
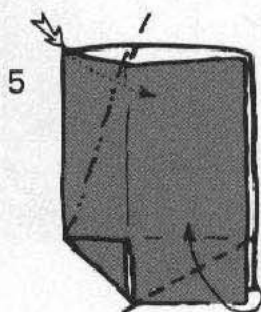
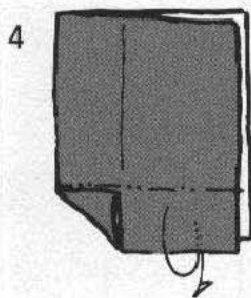
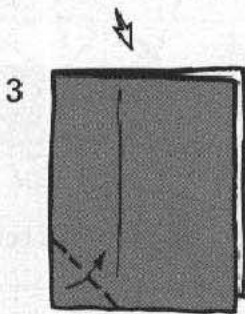

Open out completely

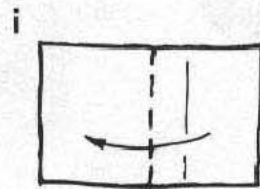
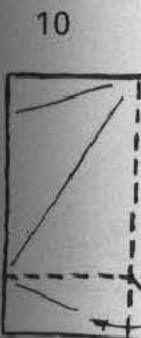

Cut 6 more rectangles of a contrasting colour. Note the position of the existing crease.

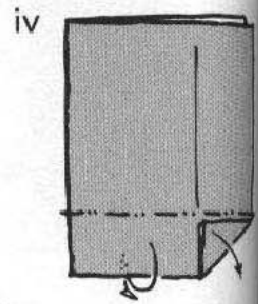
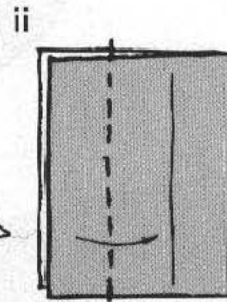

V
as

Unit B i
of Unit
will help
the draw
into mir

3a

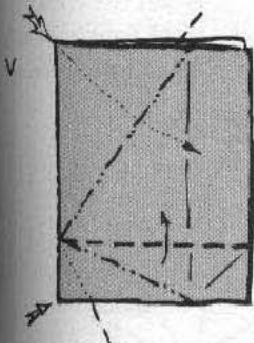

Valley and squash asymmetrically.

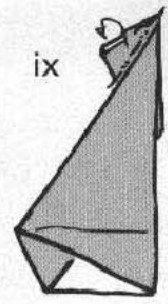
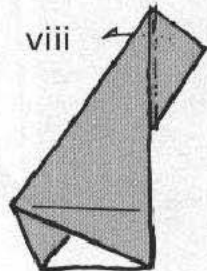
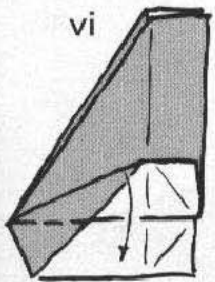

Form a 3D shape

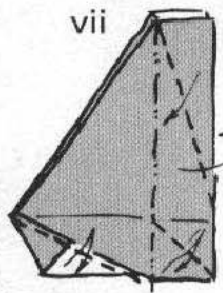
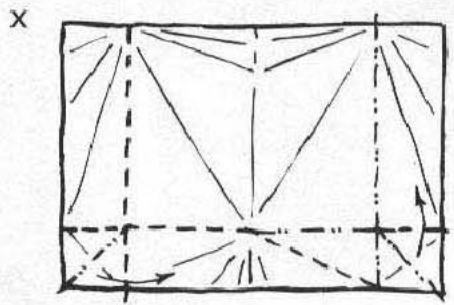

Fold all layers at the right

Unit A: 3 required

Unit B is a mirror image of Unit A. These drawings will help you translate the drawings for Unit A into mirror images.

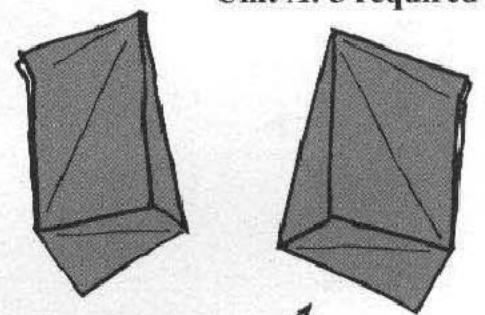
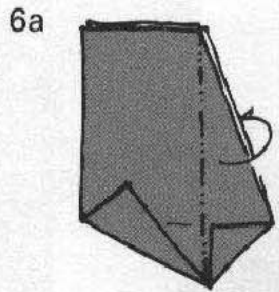
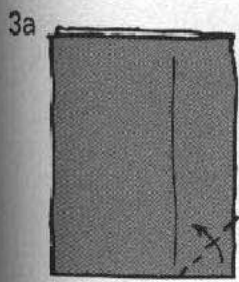

Unit B: 3 required

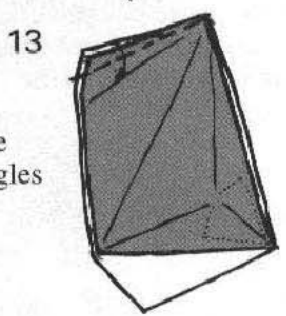

Note the positions of the small right-angled triangles between the layers

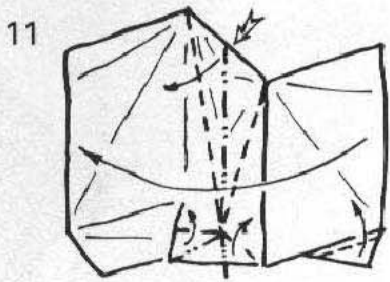
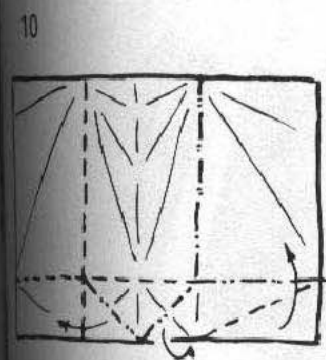

12 Insert the convex right hand side into the concave left

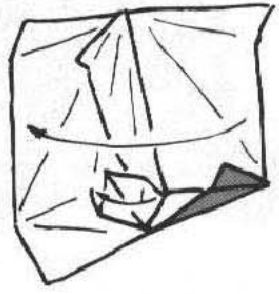

Form to a 3D shape, then collapse carefully.

xi

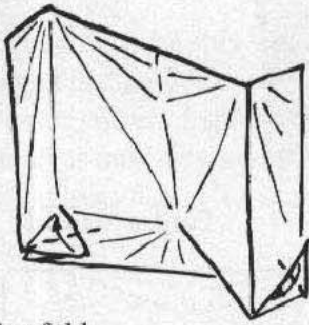

Valley fold the small corners

xii

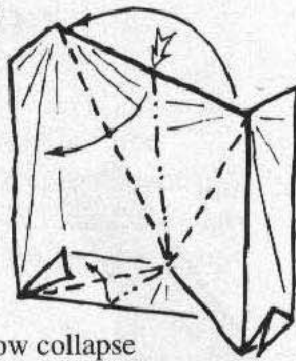

Now collapse carefully

xiii

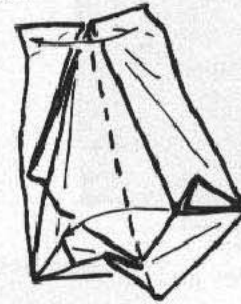

Insert the convex right hand side into the concave left

xiv

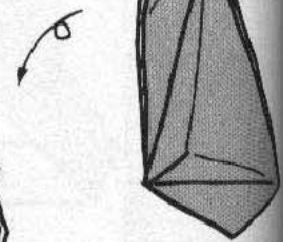

Unit C
3 required

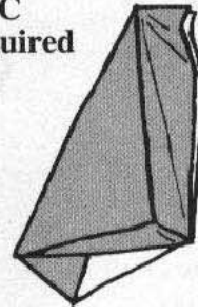

Unit D
3 required

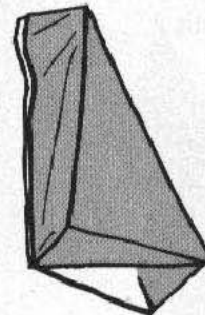

iiiA

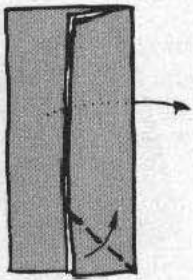

As before, Unit D is a mirror image of Unit C. The above are mirror image drawings of some of the previous steps.

vA

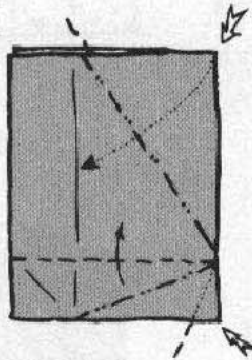

ixA

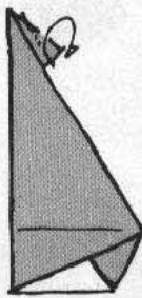

Linking of the units

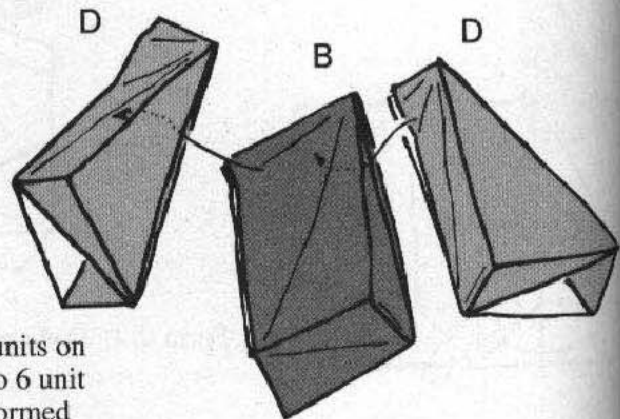
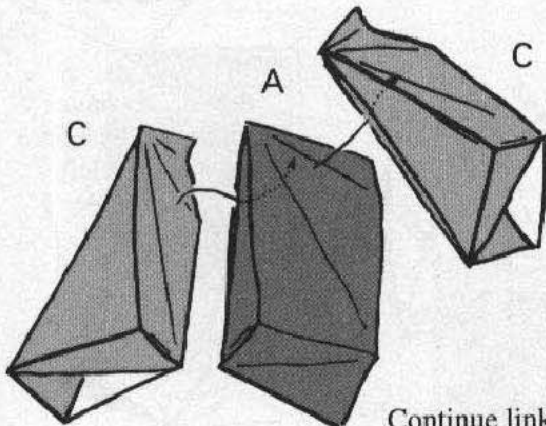

Continue linking the units on this principle until two 6 unit pyramids have been formed

ex
into
t

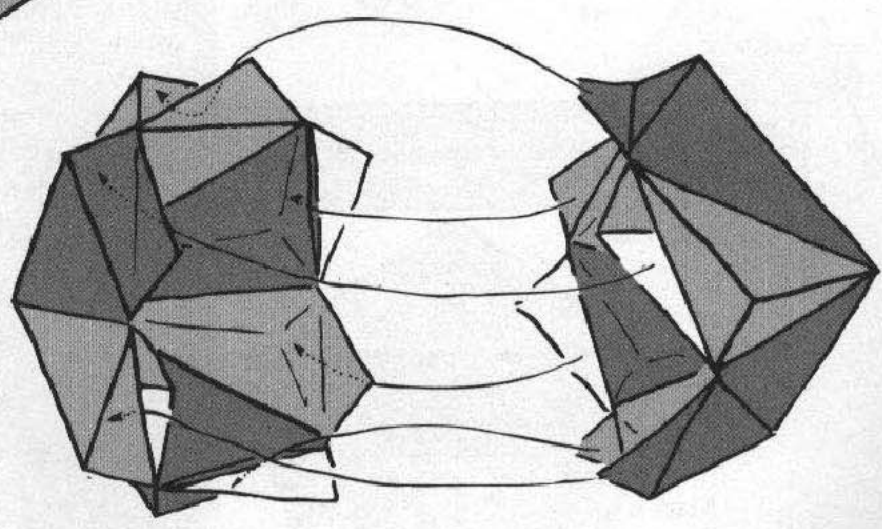
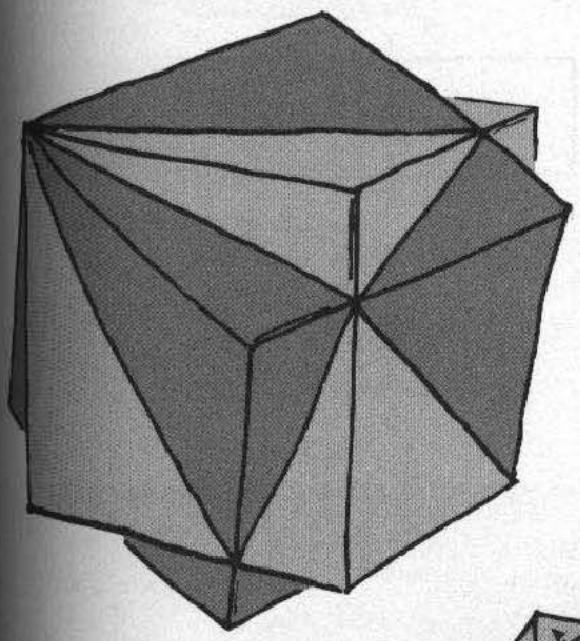
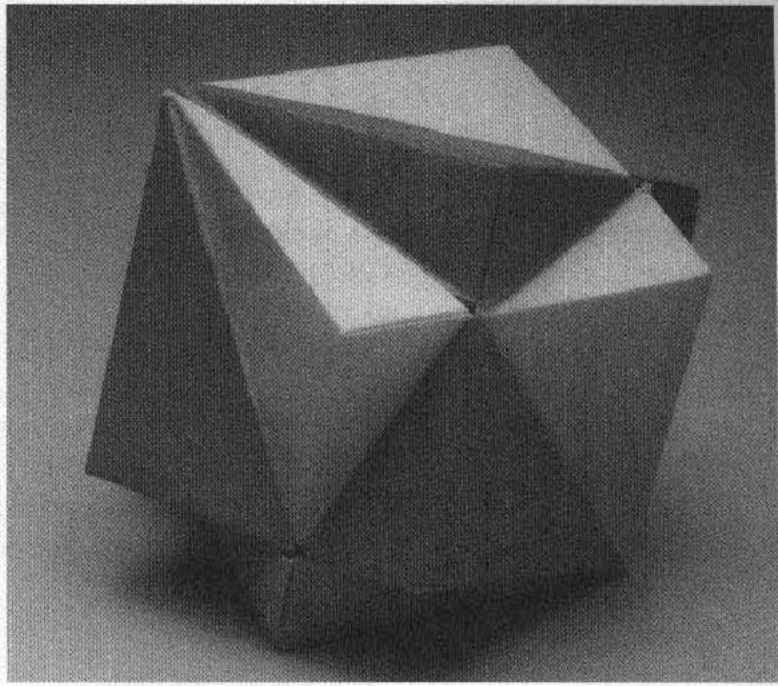

Connect the two pyramids like this:
inside flaps are inserted into inside pockets,
and outside flaps are inserted into outside pockets

Waterbombic Dodecahedron

The title of this design stems from the similarity of the faceted pyramids to a conventional waterbomb base. The stimulus for the construction was a dimpled ball, creator unknown, collected by Lewis Simon. This was made from strips with curved scored creases, linked together with cuts and slots. I was tempted to reproduce it without the slots, but was unable to reproduce the curved folds satisfactorily. The final design used straight lines rather than curves. The final locking pushing-in manoeuvres provide a good climax to the folding sequence.

Use an A4 rectangle cut in half lengthwise.
3 strips like this are needed.

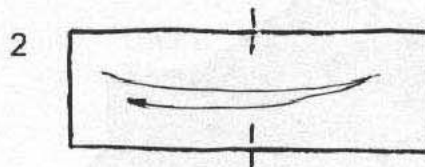
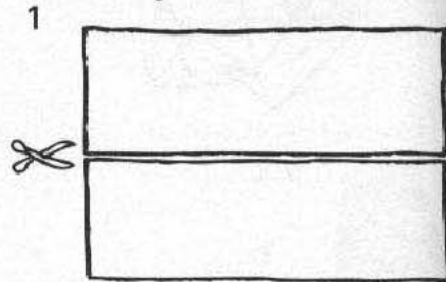

Mark the halfway point only

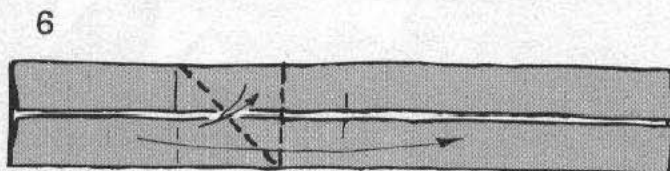
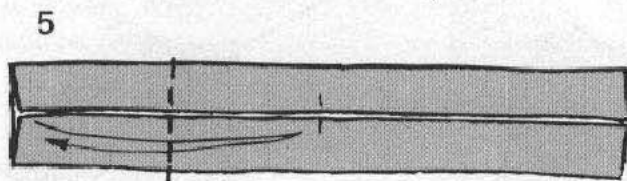
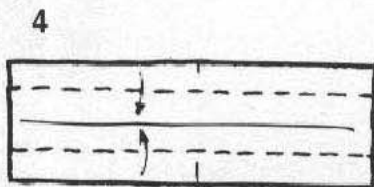
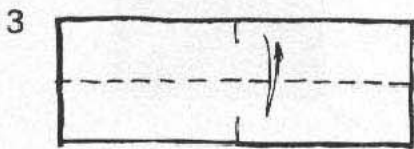

Mark a square then valley fold

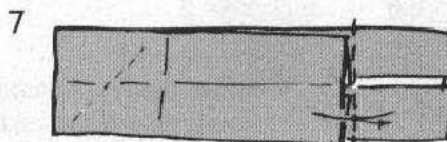

Adjust the position of the ring and form a new valley fold

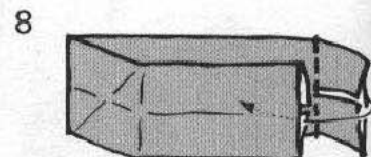
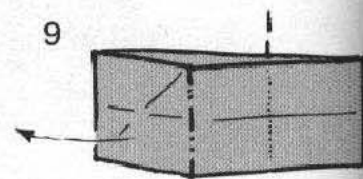

Tuck in to form a ring

12

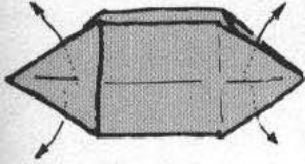

Unfold reverse folds

11

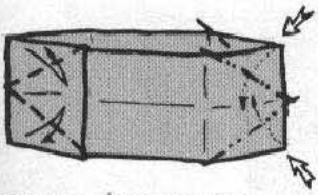

Precrease, then reverse

10

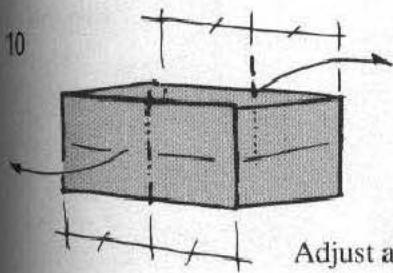

Adjust again

13

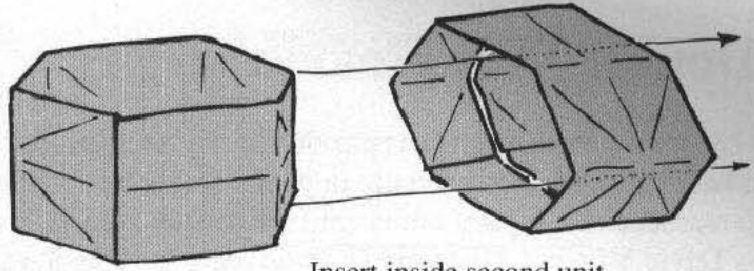

Insert inside second unit

Unit complete

14

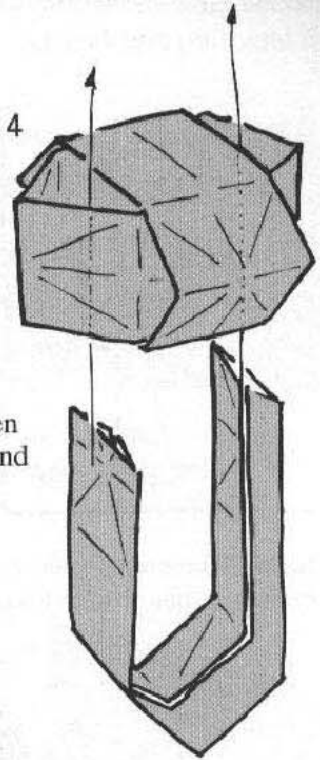

Unlock the 3rd unit, then insert into the 1st and 2nd units

15

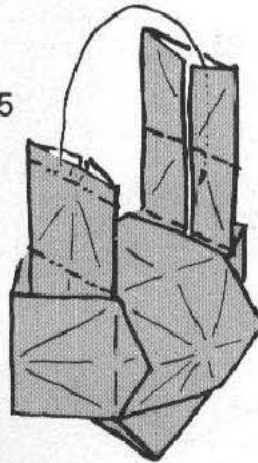

Reconnect the 3rd unit

16

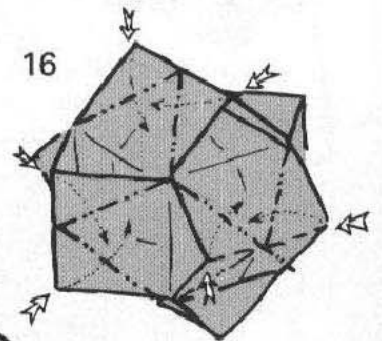

Reform all reverse folds to lock the final shape

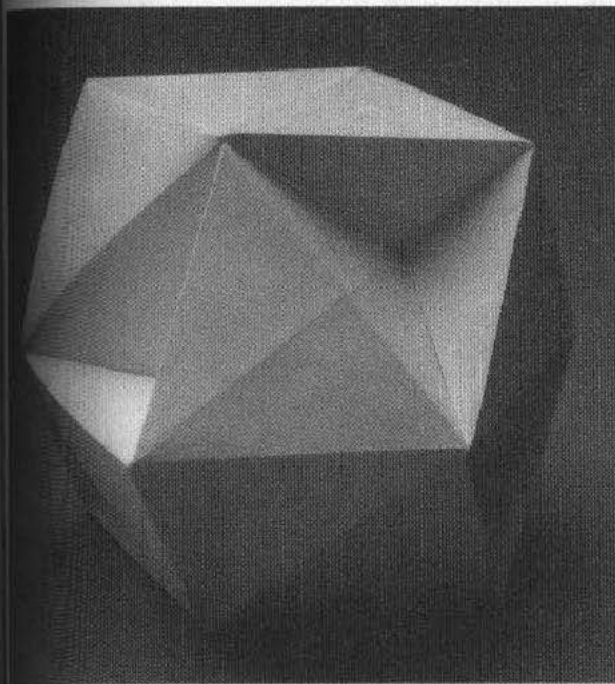
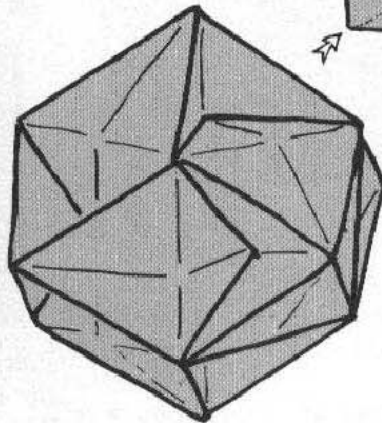

Double Star Flexicube

I had been introduced to this puzzle-like toy by Paul Jackson. It later appeared commercially in plastic. I felt it impossible to reproduce in origami terms until I saw a six-piece star puzzle by David Mitchell. His design, reproducing in paper a wood-block puzzle gave me a clue to folding this result. It needs a little care in handling and flexing.

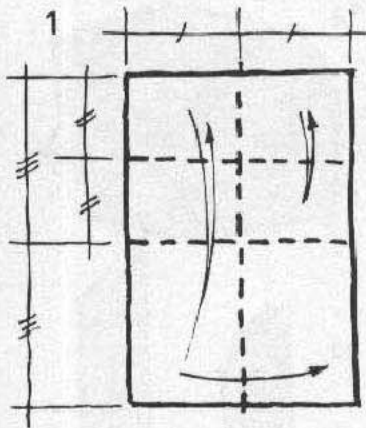

Use an A6 rectangle; see p. 22. precrease, then fold in half.

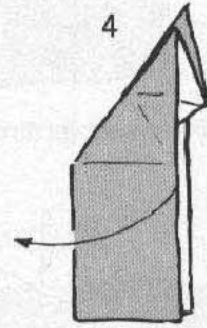
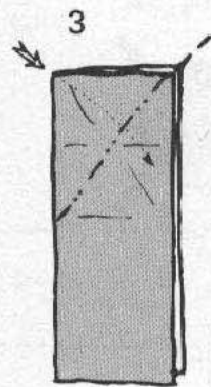
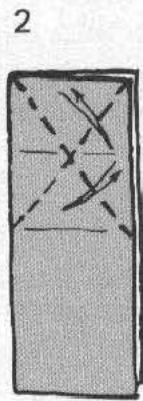

Open

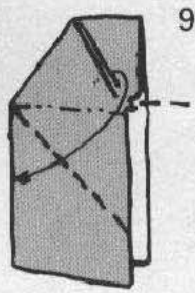
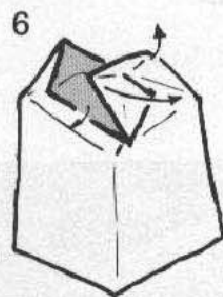
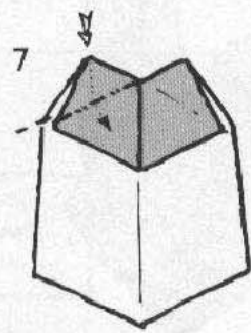
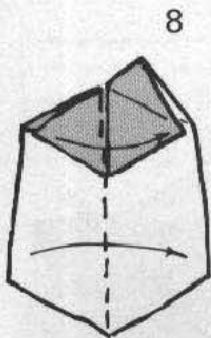
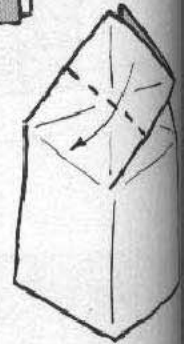

Open to form a 3D shape

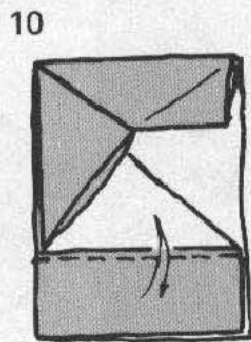

Precrease to complete one right-hand unit. 24 units like this are needed.

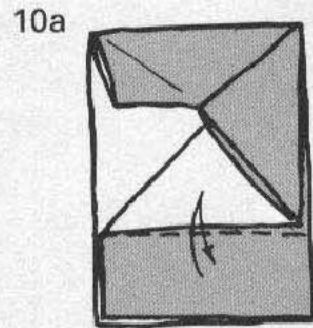

Left-hand unit. All steps 1-10 are seen as mirror images. 24 units needed.

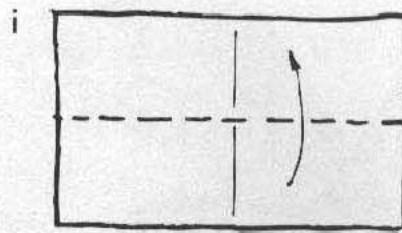

Hinge unit: use an A6 rectangle

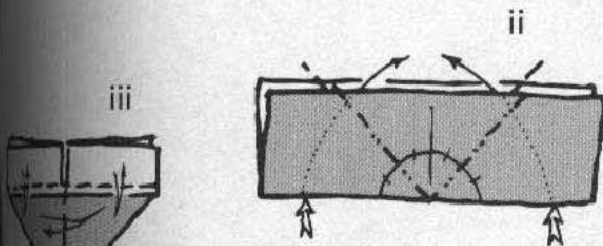

16 hinge units are needed

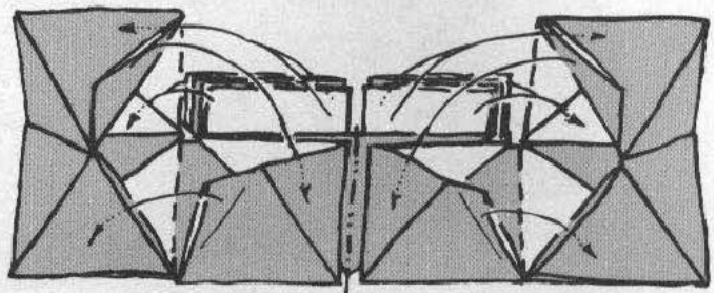
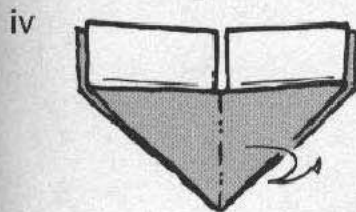

14 Re-form the two half-cubes, this time including the hinge unit.

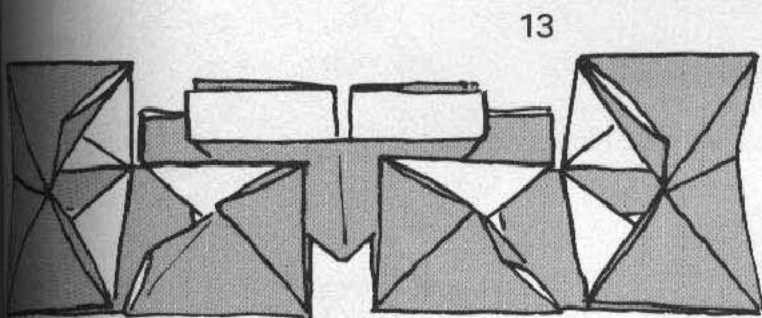

Method of inserting a hinge unit into a right-hand half-cube and a left-hand half-cube. Carefully open out the units which will accept the hinge unit.

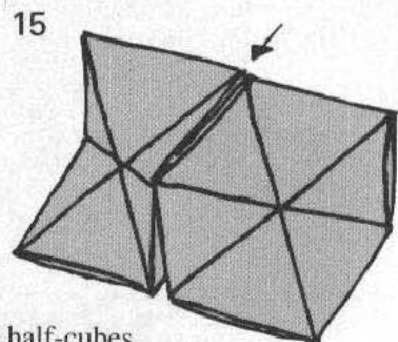

2 half-cubes connected by the hinge unit: The arrow indicates the position of the hinge.

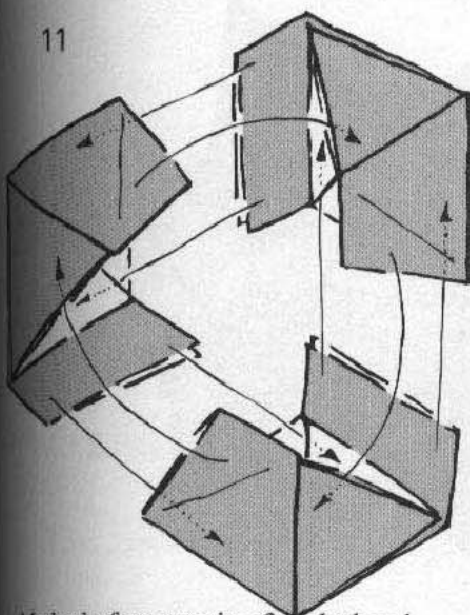

Method of connecting 3 right-hand units to make a half-cube.

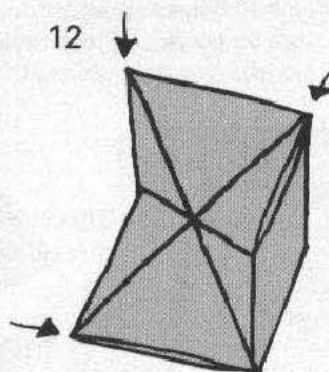

Half-cube made from 3 right-hand units.

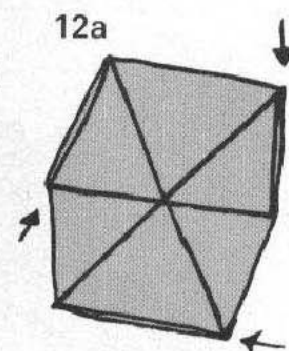

Half-cube made from 3 left-hand units

The arrows point to the 3 edges into which the hinge units can be inserted.

16

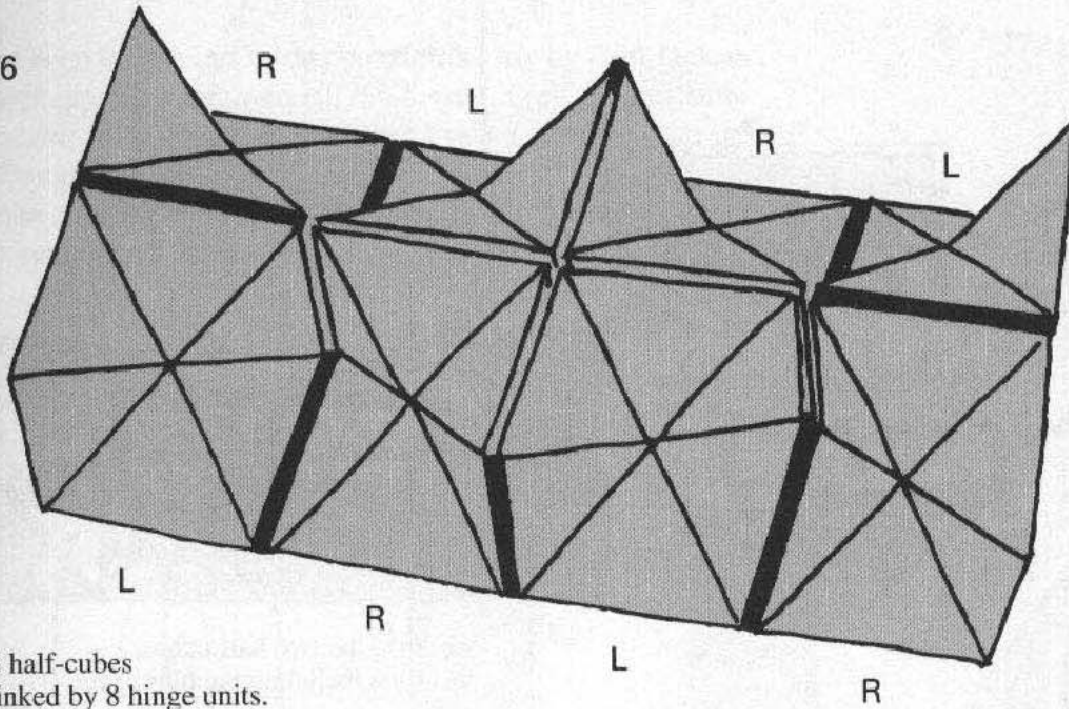

8 half-cubes
linked by 8 hinge units.

L & R indicate half-cubes
made from left and right handed units respectively.

The heavy black lines indicate the position of the hinge units

2 of these constructions are needed

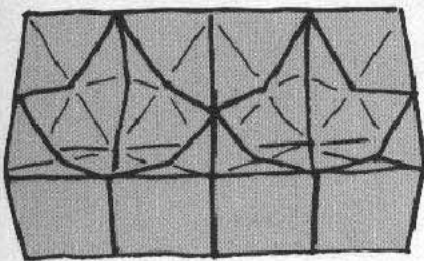

This shape
can contain the
shape shown
on the right

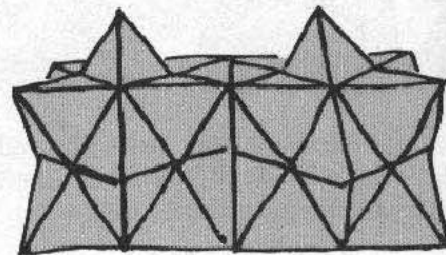

These structures can be formed
by flexing the construction shown in 16

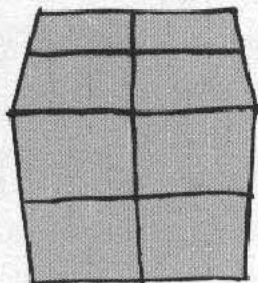

This cube will contain this
three-dimensional star.

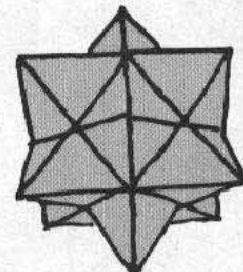

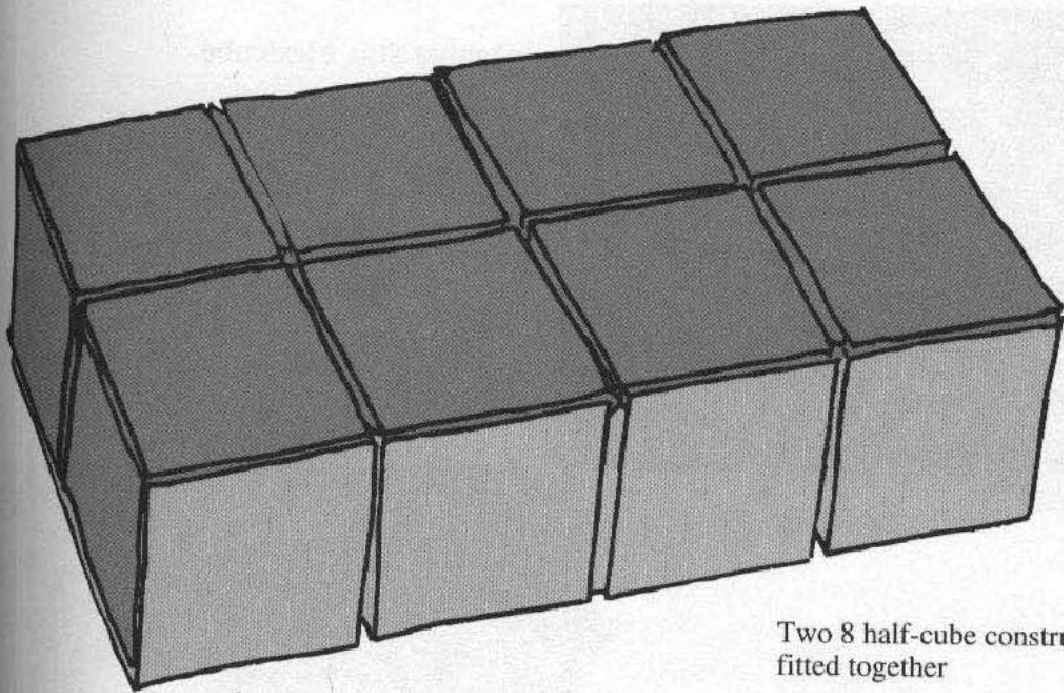

Two 8 half-cube constructions fitted together

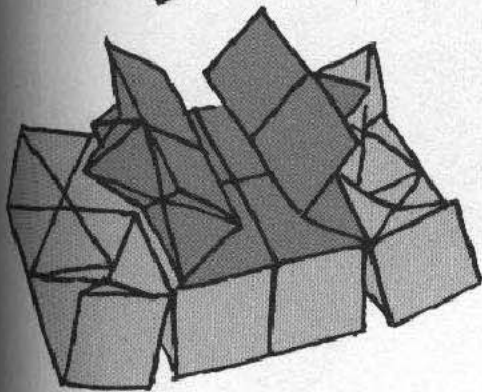

This shows one star emerging: the other half can then be formed into an identical star.

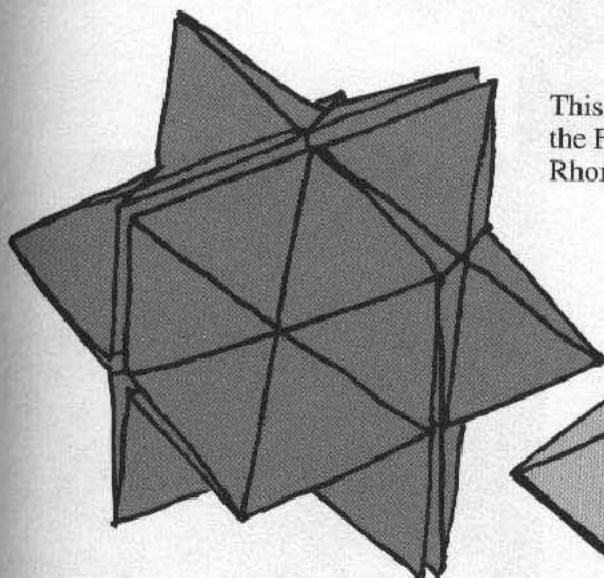
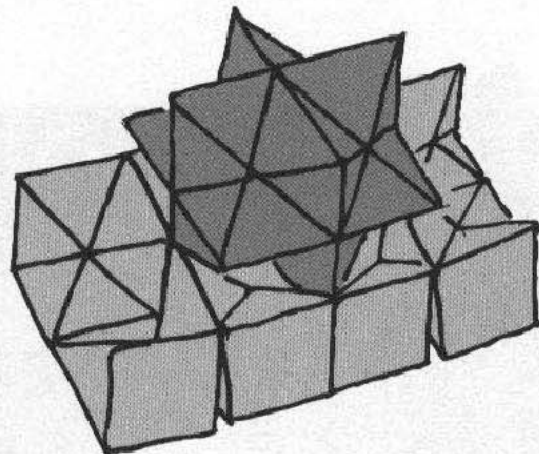

This star shape is known as the First Stellation of the Rhombic Dodecahedron

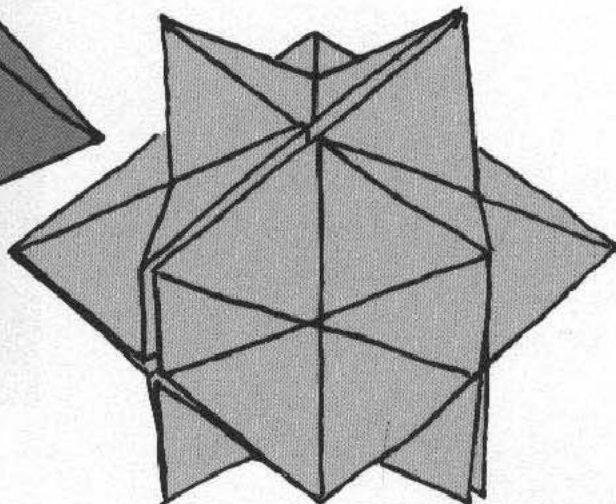

Double Star Flexicube

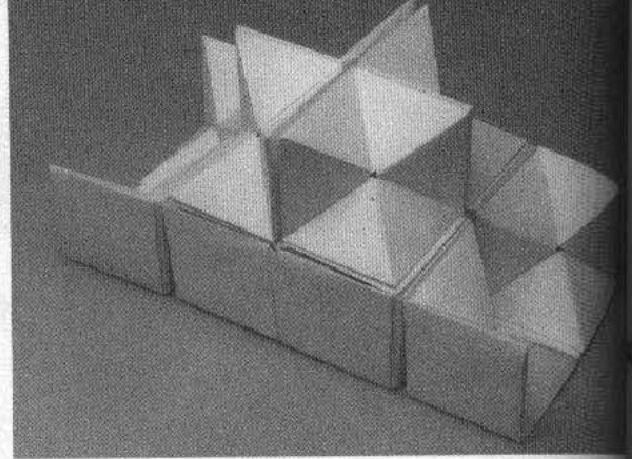
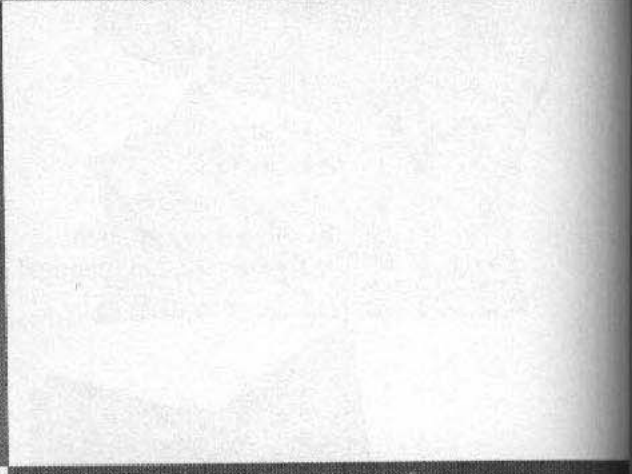
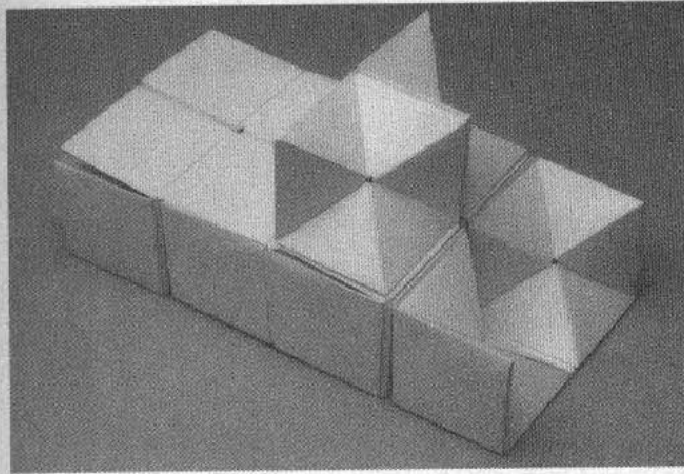
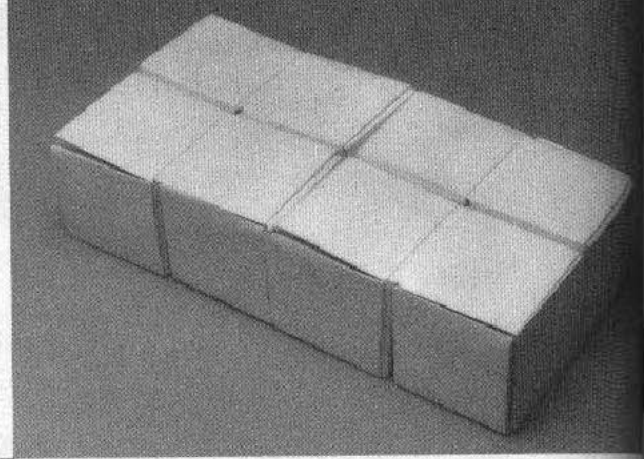
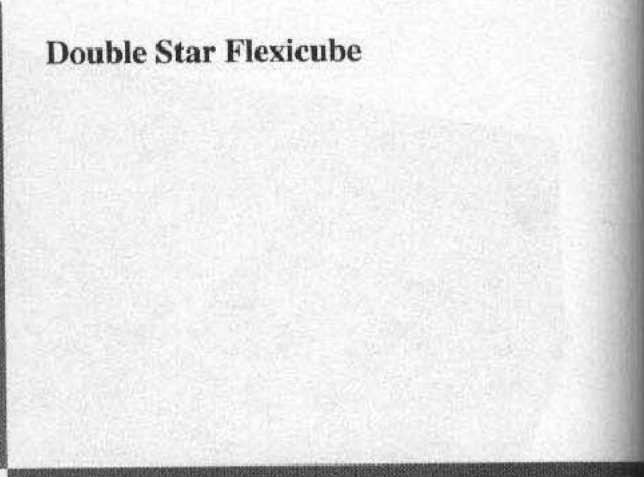
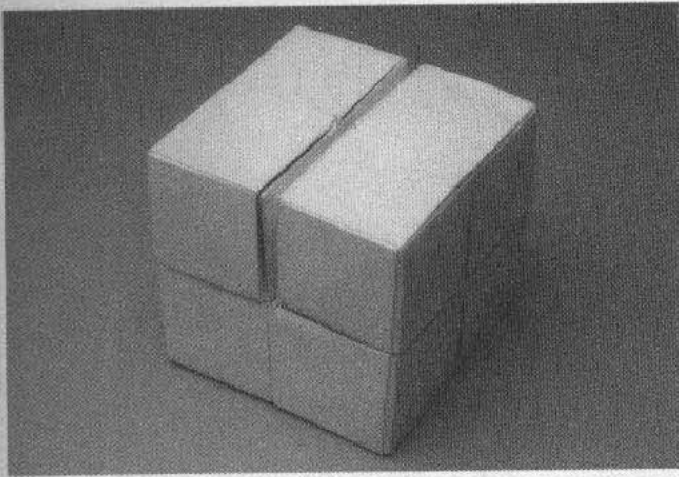

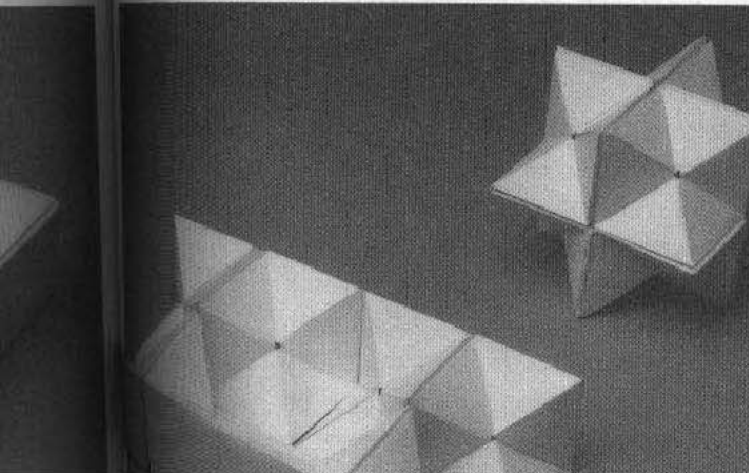
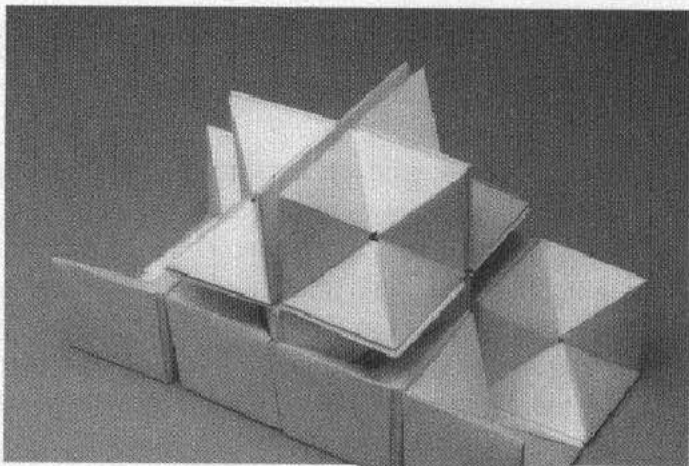

Faint, illegible text, possibly bleed-through from the reverse side of the page.

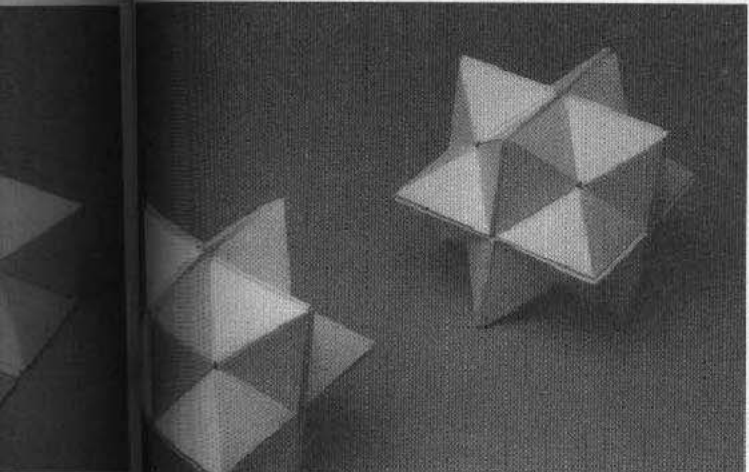
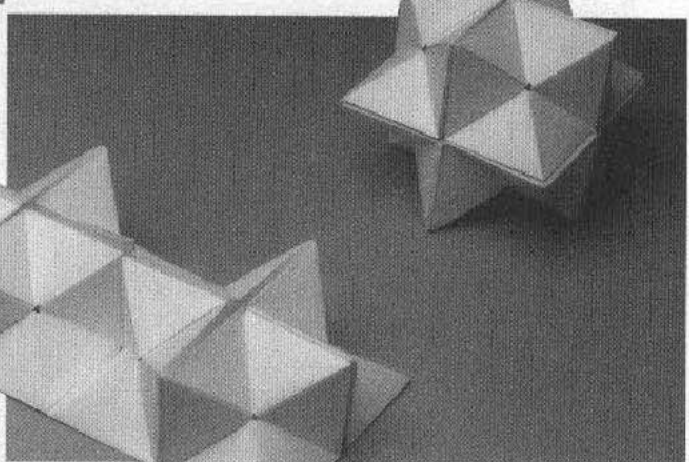
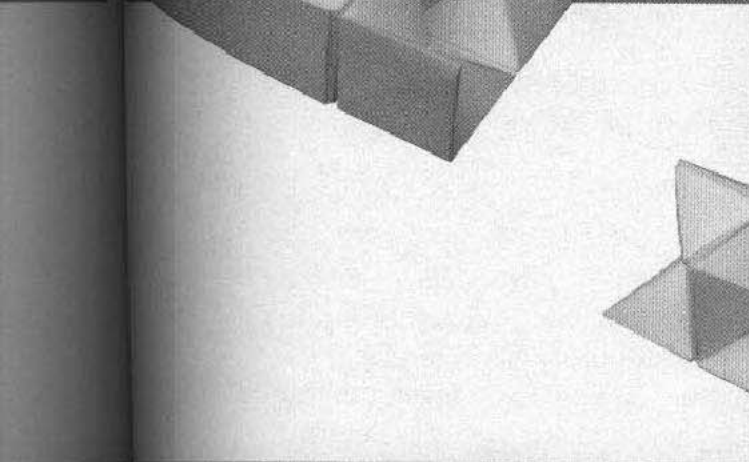

Wet Folding Techniques

To the purist who prefers not to introduce any outside tools to influence the direct dialogue between paper and folder, the technique known as "Wet Folding" may not be immediately attractive. However it is an interesting and useful skill which isn't difficult to acquire. Indeed a lot of mystery has been attached to the process, which is in fact quite a straightforward one

Particularly suited to animals and living forms, wet folding has been pioneered by the Japanese master, Akira Yoshizawa. Its advantages include the ability to give both sharp creases and soft curves. The finished form will be much more solid than its dry paper counterpart, and large models can be folded from thickish sheets. These will support their weight and are less likely to collapse than the same subject folded conventionally.

Essentially the technique involves lightly wetting the paper before folding, folding swiftly and smoothly, and then allowing the result to dry. You should pay attention to the shape and three dimensionality of the model at all times. Yoshizawa has also used and described a development called "urauchi", where two layers of paper of different thicknesses are sealed together with thick flour paste. The layered sheet is then carefully stuck to a board by its edges with thin line of the same paste, and then left to dry. The sheet is then carefully removed from the board, now quite taut and wrinkle-free. It can then be dampened again by using a spray or a wet towel, prior to folding.

I suggest the following tips may help those new to the idea of wet folding techniques.

- Choose a thickish paper. I have used the heavier grades of Fabriano or Canson paper to good effect, and have found that even common brown wrapping paper works too.

- Don't over wet the paper: it should be floppy, though not dripping with moisture.

- Useful tools are a spray bottle which gives an even, drip-free mist, a towel, lightly moistened, paperclips or clothes pegs to hold layers together while drying, and possibly also a hair-dryer to speed drying of the finished model.

- It may be necessary to re-wet the paper during the folding process, but I prefer to avoid this as it's difficult to ensure that all layers within are evenly penetrated by the water.

- Make sure that you are completely familiar with the folding sequence of your chosen design: If folding from a book or diagrams, learn the method by heart before you begin.

- Fold swiftly and accurately, in the air if possible, as soon as the design has reached a manageable size.

I believe it's well worthwhile trying this process which will expand your knowledge of the behavior of paper while being folded. The results will be permanent and often well-suited formal exhibitions or displays.

Animals

This must be the most popular subject in origami: it is certainly one of the most challenging too. In the following pages I have tried to show a range of animals which I worked long and hard over in the 1970s and 1980s: I have tried to make them all three dimensional and with an element of life. Unfortunately it is not always easy to show the finer points of folding in the accepted diagramming style which I have used, but I hope that the photographs of the finished subjects will fill in any gaps in the information.

My only message is to persevere if your first folding attempt is unsuccessful. A second go will almost always give a better result. Please try your own variations too: this may open the door to your own creative origami career.

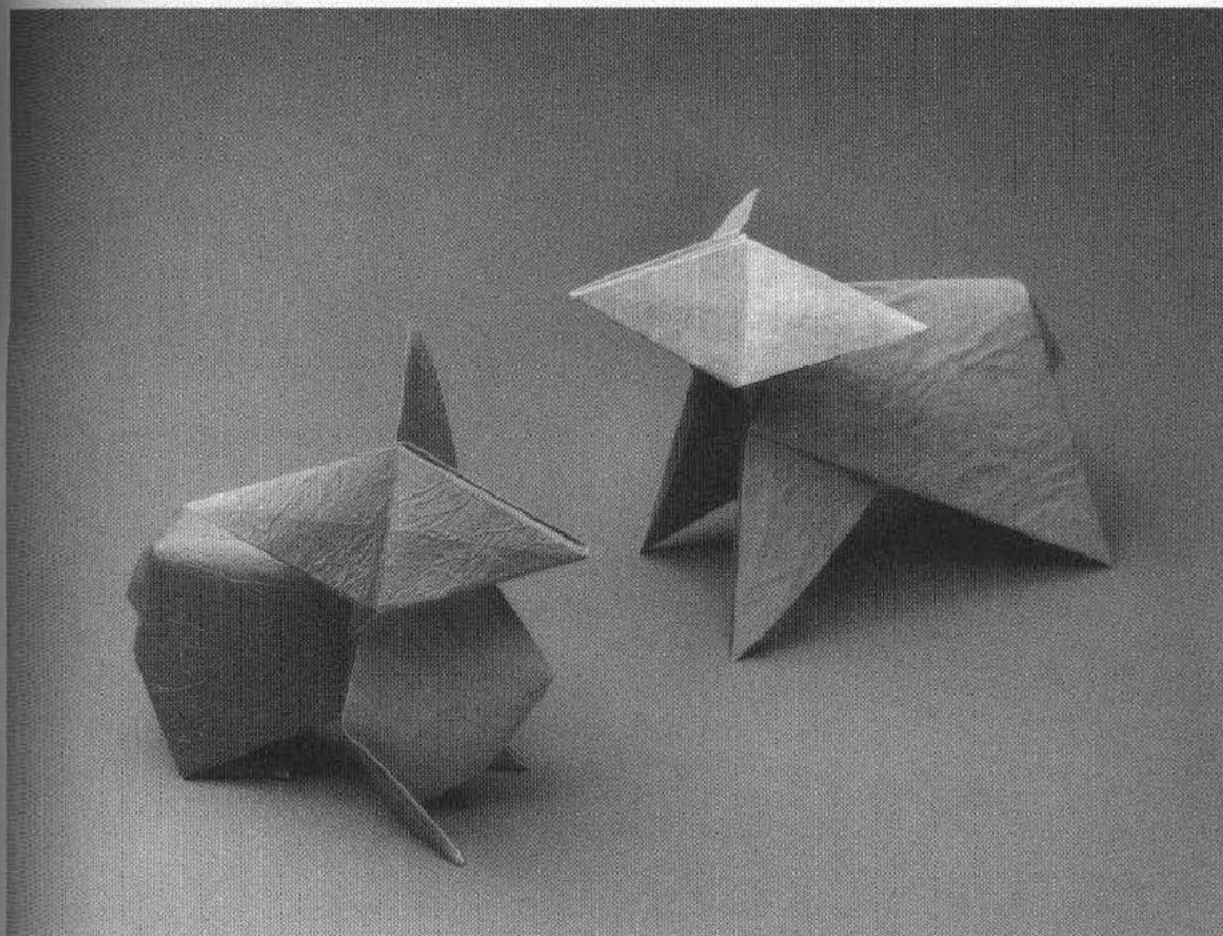

Lamb and Corgi (p. 106)

Lamb and Corgi

These are relatively simple animals, both in folding method and finished form. The reverse fold in step 12 needs careful positioning. I tried some variations with longer rectangles with the hope of making longer legged animals, but the results were not a success. The head and ears section has been used to form the base for the human figure; see p. 197.

1 Use half a square for the Lamb, and the other half for the Corgi

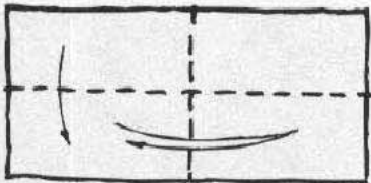

2

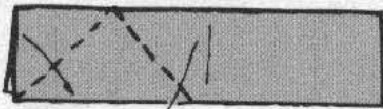

3

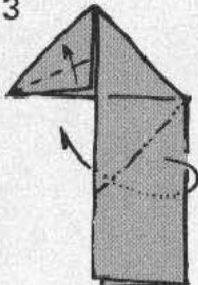

4

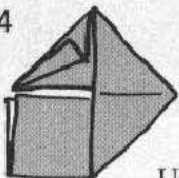

Unfold completely

5

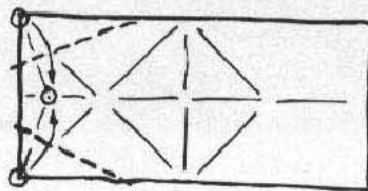

Repeat 8 & 9 on the upper side

9

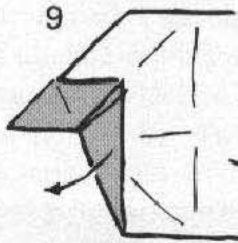

8

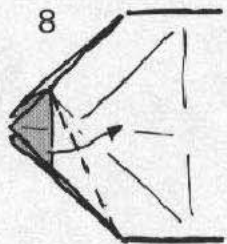

Precreasing of the neck

10

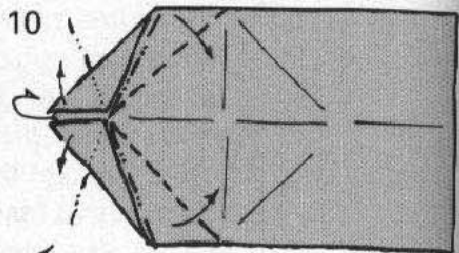

Collapse. The nose goes down behind, while the ears move outwards

7

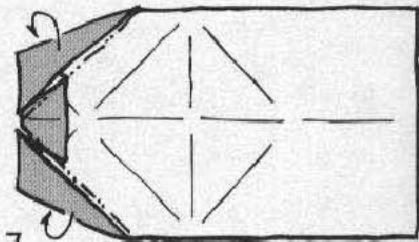

6

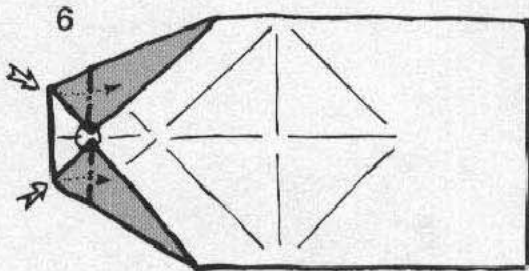

Reverse fold to form the ears

11

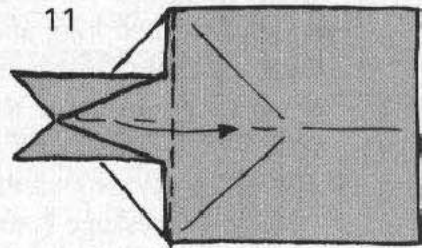

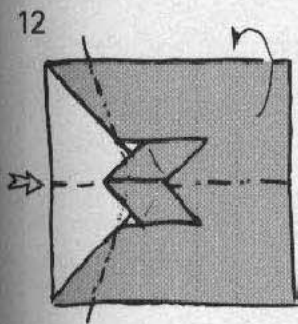

Reverse fold while folding in half

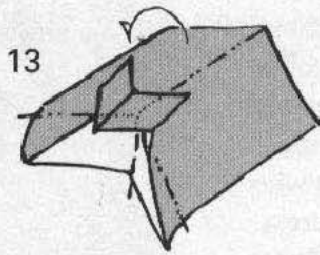

Move in progress

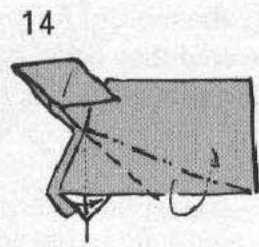

15

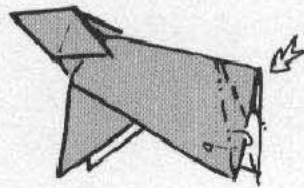

Form the rear legs and the tail

16

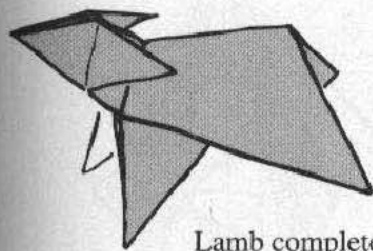
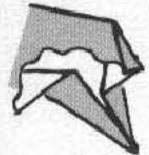

Lamb complete

17 The Corgi begins with a completed Lamb

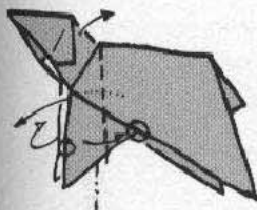

Pull out the white triangle within while reverse-folding the neck

18

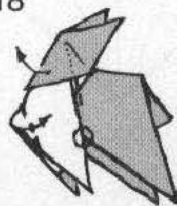

19

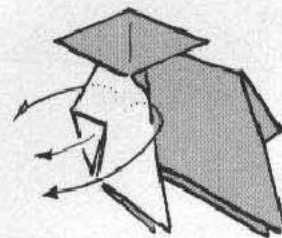

Open up to lock the chest

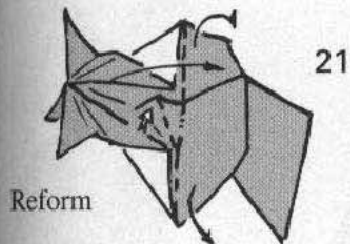

Reform

21

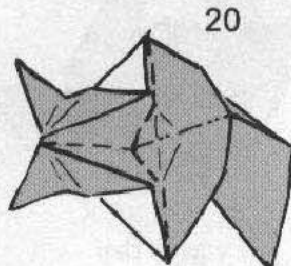

20

Carefully push down the back to make it round and 3-dimensional

22



23

Valley fold the front legs & mountain fold the back legs

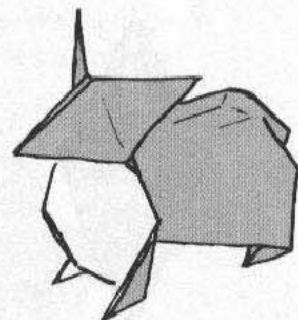

Corgi complete

Another simply formed animal which uses a variation of the fish base. The technique forming ears was borrowed from Robert Neale's Harlequin mask. The guinea pig was made to order (and actually came before the mouse) for some friends who discovered they had a common interest in these animals which they kept as pets.

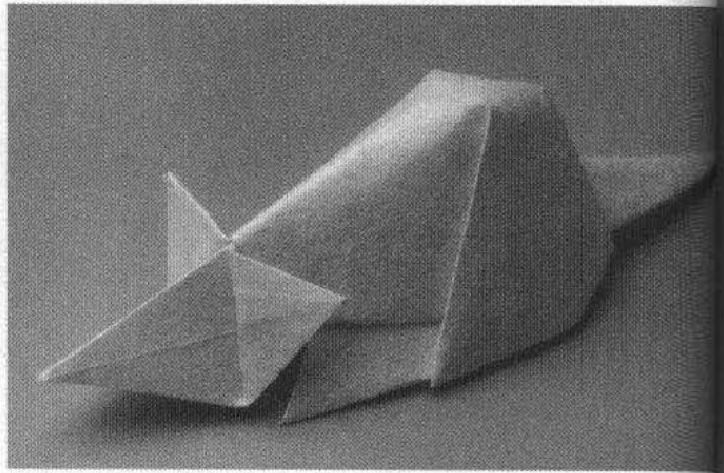

Mouse

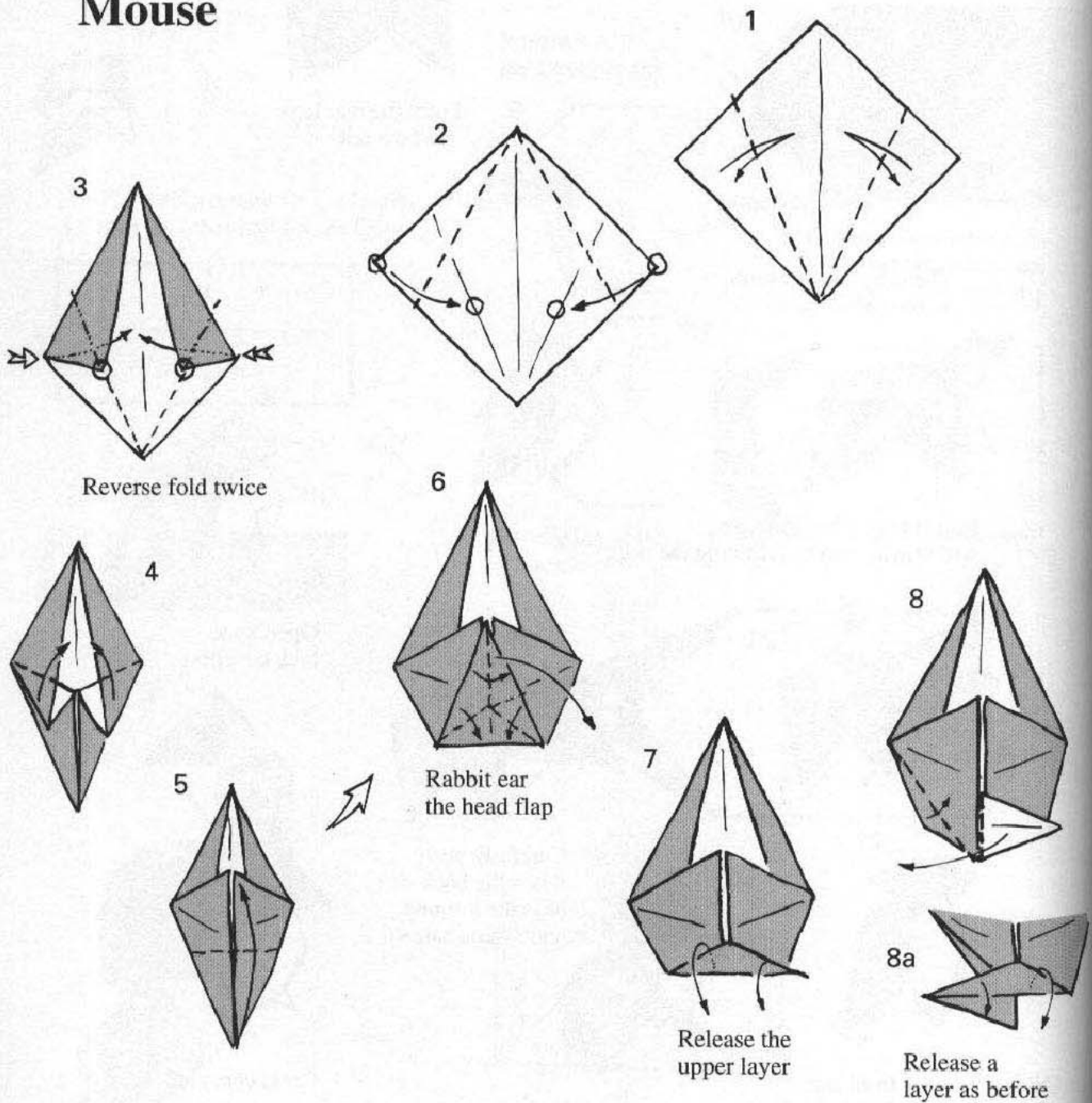

11a

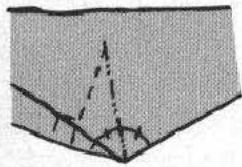

Note that the crimp forming the rear legs does not meet the centre line and gives the mouse a 3D shape

11

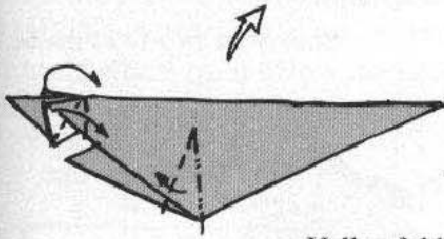

Valley fold the ears front and back

12

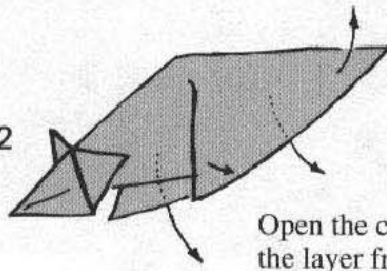

Open the crimp and the layer from within

10

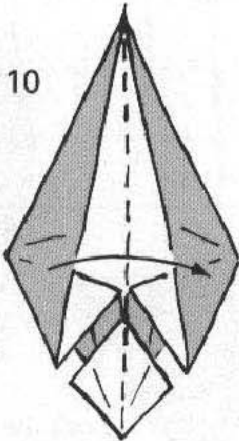

Reform the crimp and lock by mountain folding

13

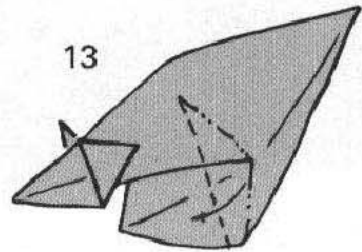

14

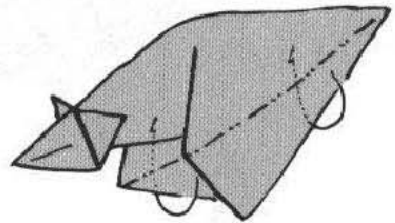

15

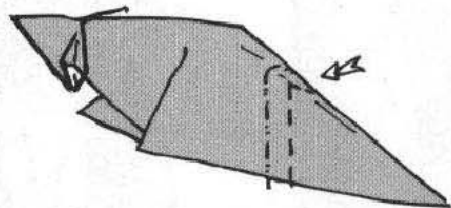

Narrow the tail: note inside view

16

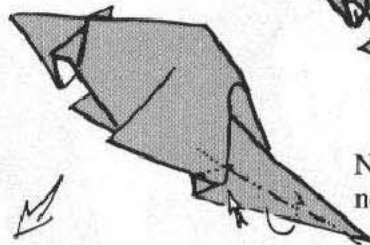

16a

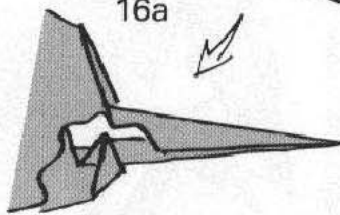

9

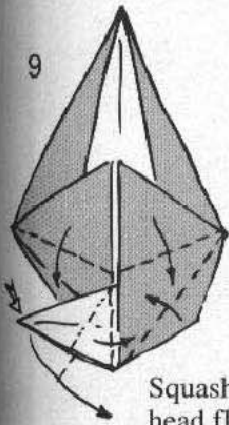

Squash the head flap

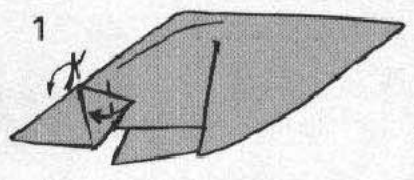
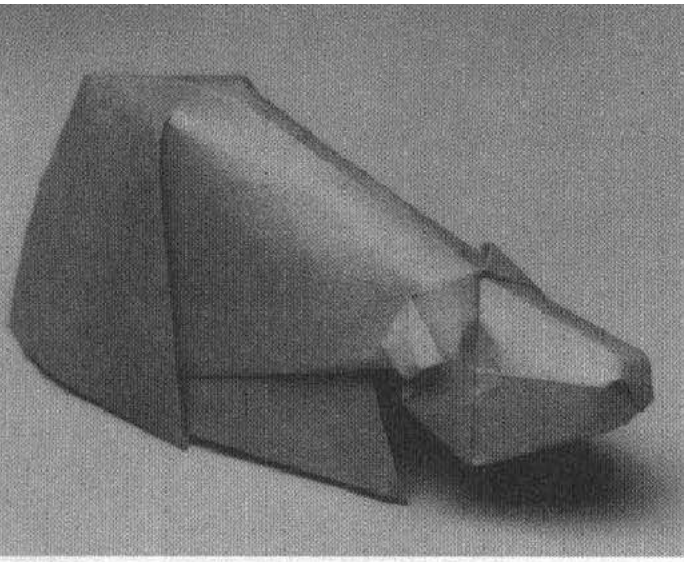

Start from step 14 of the Mouse

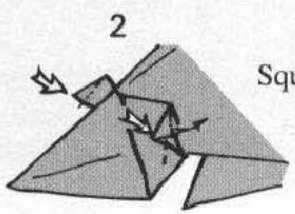

Squash the ears

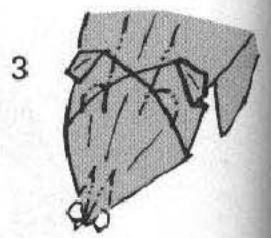

Form the eyes by pushing in on the folded edge

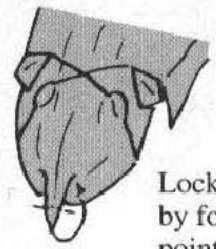

Lock the nose by folding the point underneath

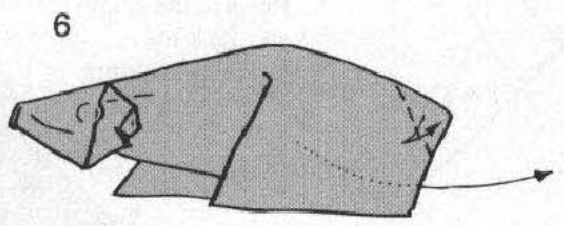
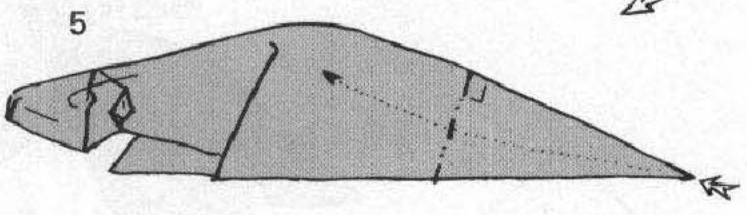

Guinea Pig

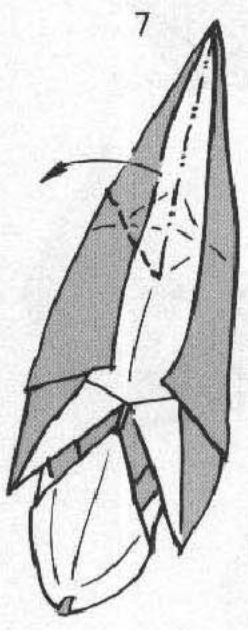

Pleat the pointed flap to the left

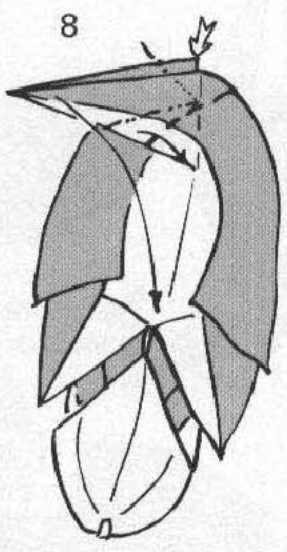

then valley fold inside the body trapping a small triangle within.

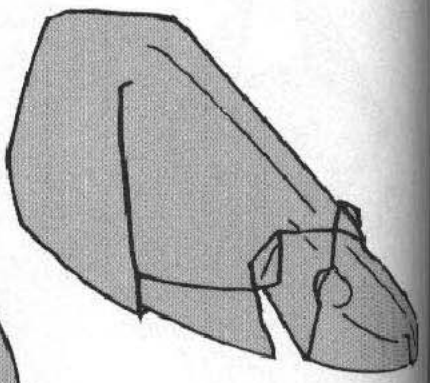
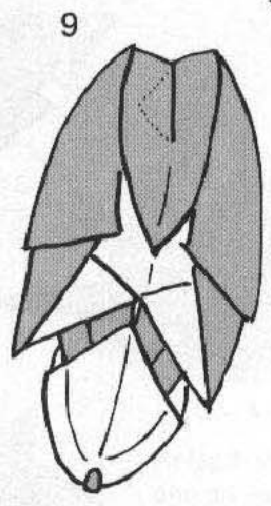

I was anxious to avoid all logical reference points when creating this animal, although I confess I have tidied up the method in these diagrams. The twisted head was a compromise to release the ears from below the head, but the positioning gives the rabbit a lively feel.

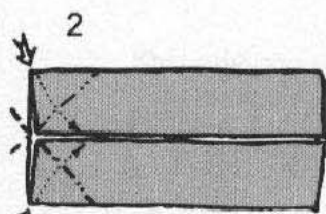
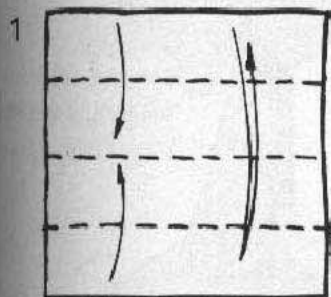
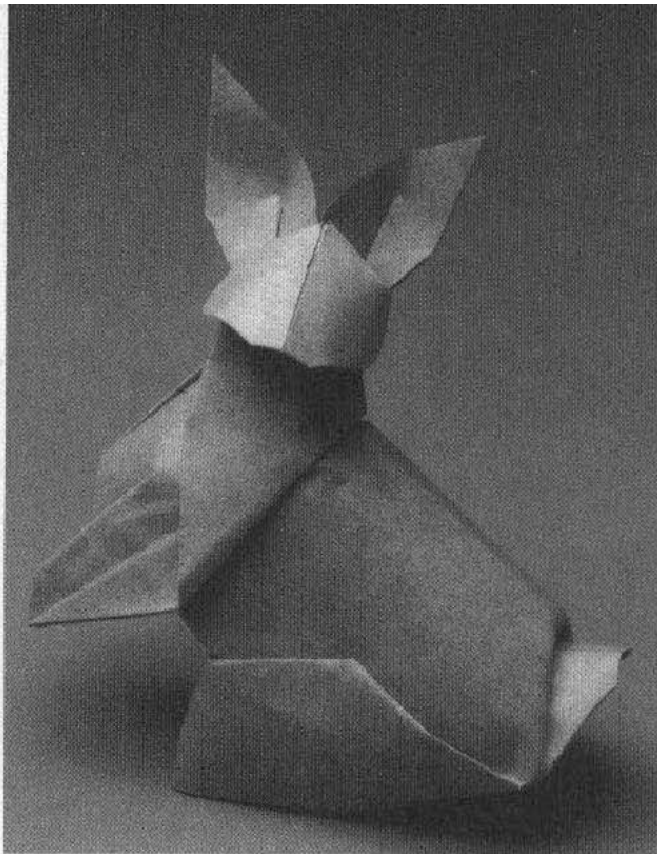

Reverse fold

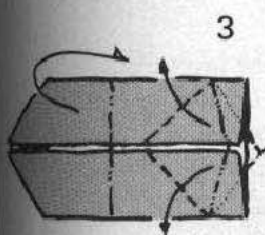

Form the rear legs by a sort of petal-fold

Rabbit

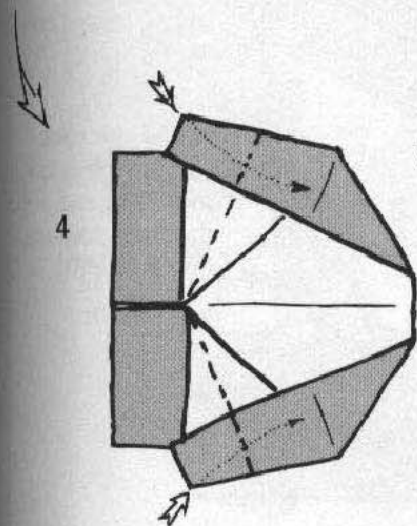

Shorten the rear legs

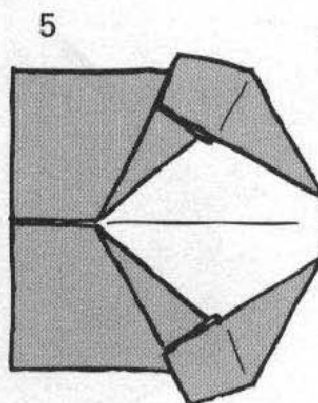

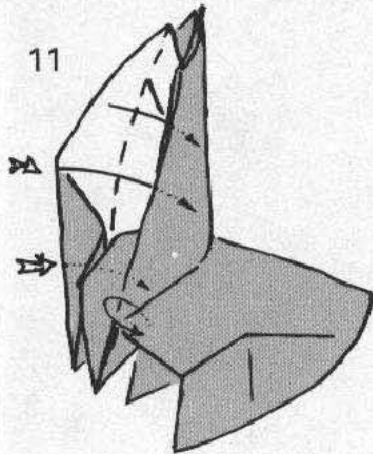

Then replace the single layer. Tuck one layer of the leg behind the head flap

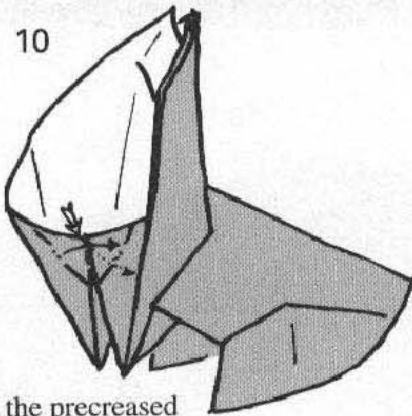

Push the precreased corner behind

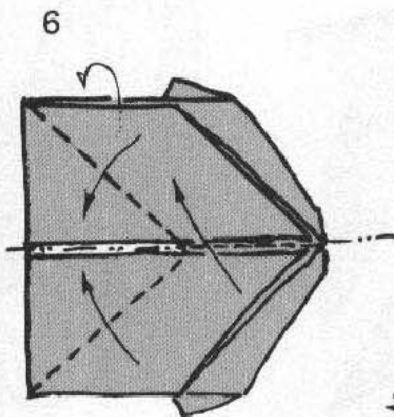

Form the head section with a rabbit-ear while folding the body in half

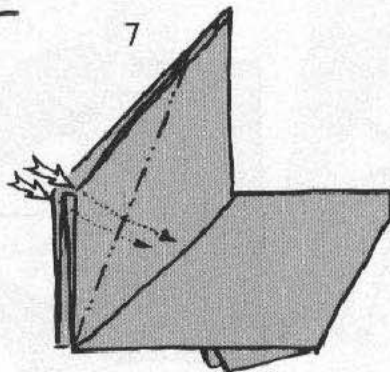

Sink twice

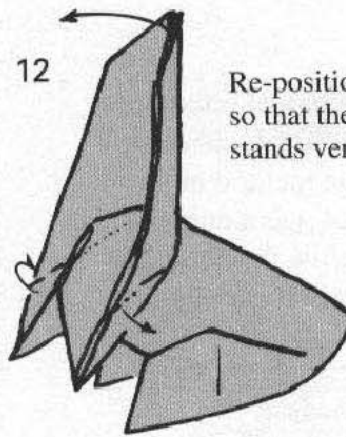

Re-position the head so that the front edge stands vertically

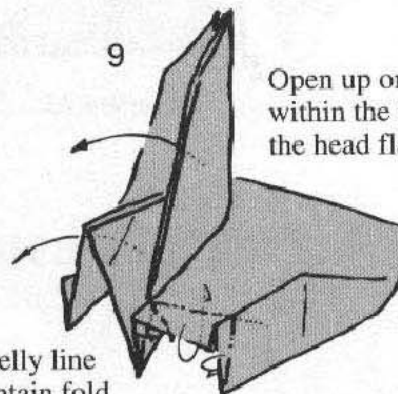

Open up one layer from within the back of the head flap

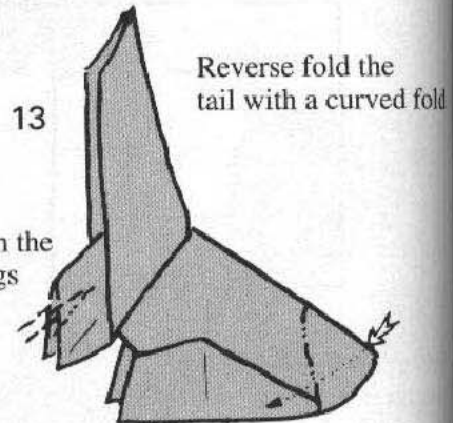

Reverse fold the tail with a curved fold

Pleat to form the two front legs

Shape the belly line with a mountain fold simultaneously shaping the front and rear limbs

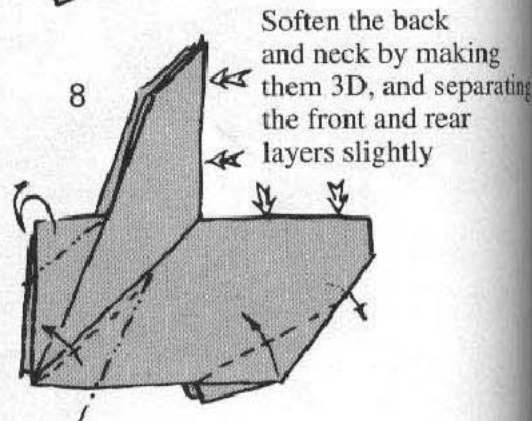

Soften the back and neck by making them 3D, and separating the front and rear layers slightly

Pleat the front legs, and pull out the preformed rear quarters. Precrease the right-angled corner

Shape the back of the neck
and valley over one vertical
edge of the head flap

14

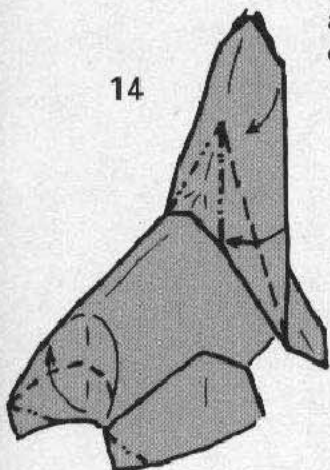

Form the tail
with a 3D petal-fold

15

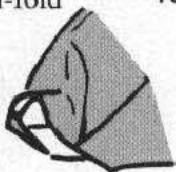

Outside reverse fold
the head

16

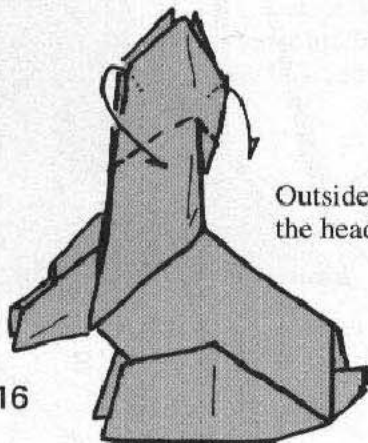

Shape the ears
with small pleats

17

18

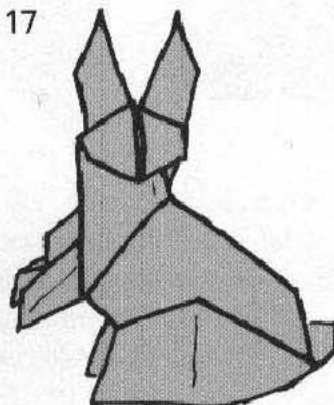

19



Tuck in the corners
of the head in front
of the ears

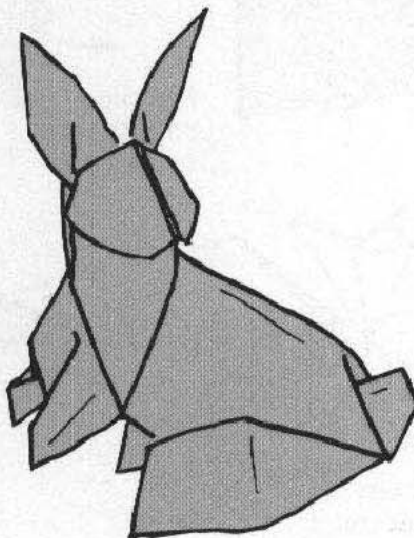

Goose

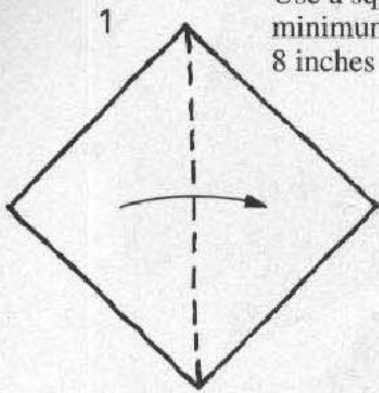
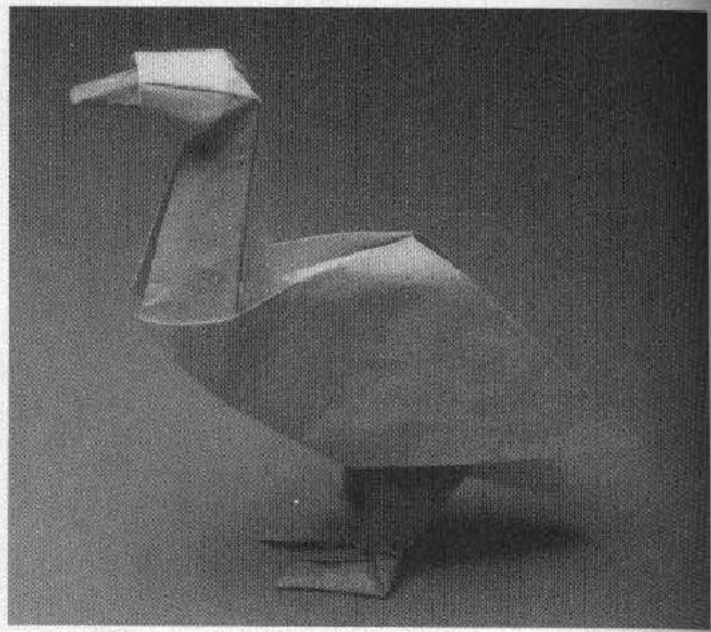

Use a square
minimum size
8 inches (20 cms)

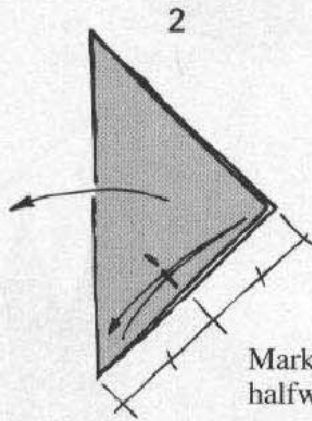

Mark the
halfway point

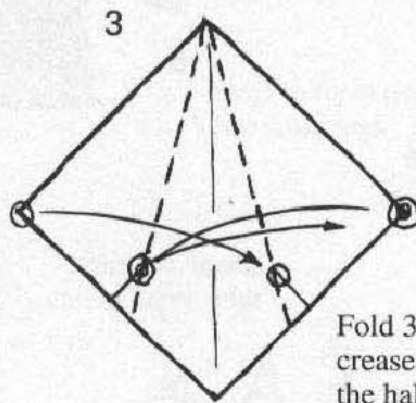

Fold 30 degree
creases using
the halfway marks

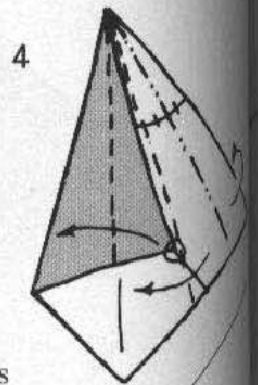

11

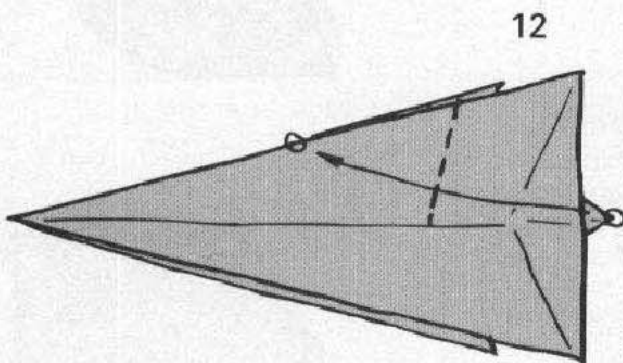
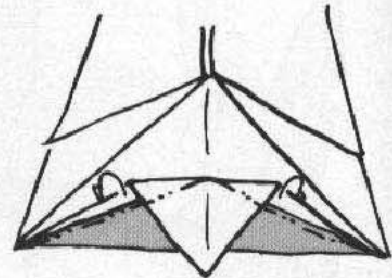

Precrease
on both sides
as shown

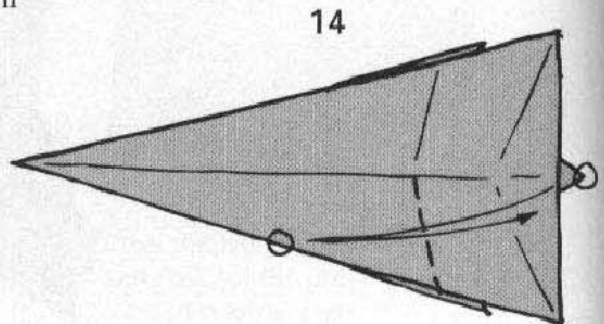
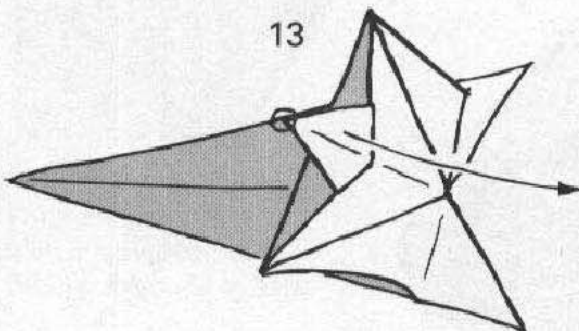



Reverse folds

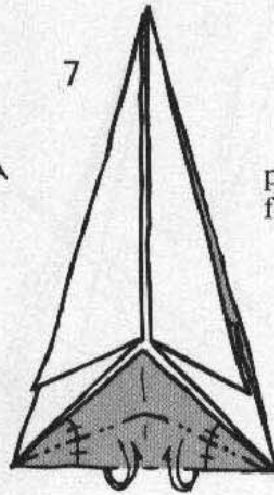
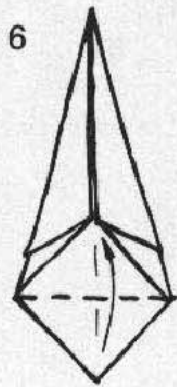

precrease mountain folds

8

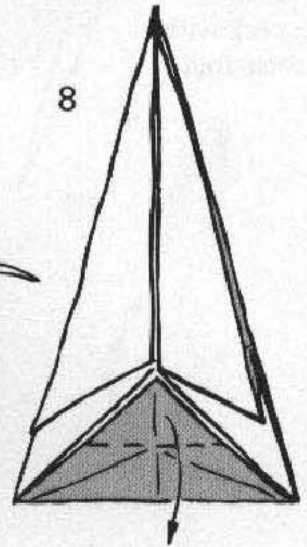

9

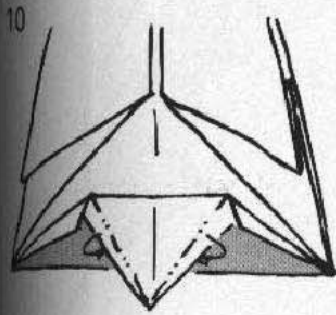
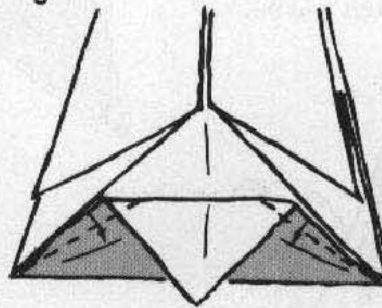

Another "folded to order" design. Birds have not been a major success in my origami catalogue and an attempt at a robin more closely resembled a hawk! You may detect the influence of Akira Yoshizawa, who folded a swan for me when I visited him in 1980. Yoshizawa's swan had a most elegant neck which I have not managed to duplicate in this design.

15

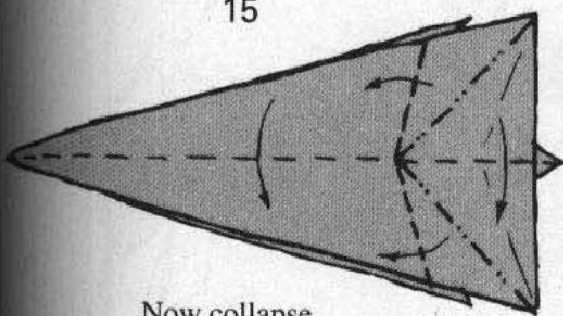

Now collapse to form the body and rear legs

16

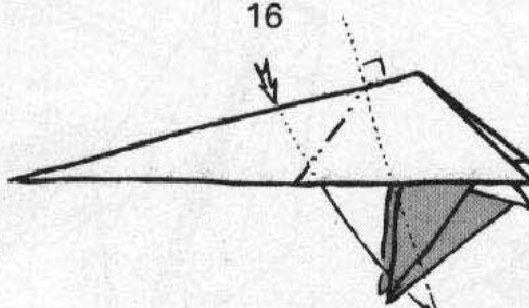

17

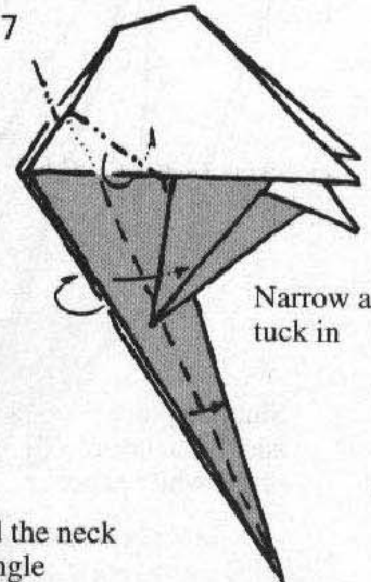

Narrow and tuck in

Reverse fold the neck noting the angle shown here

18

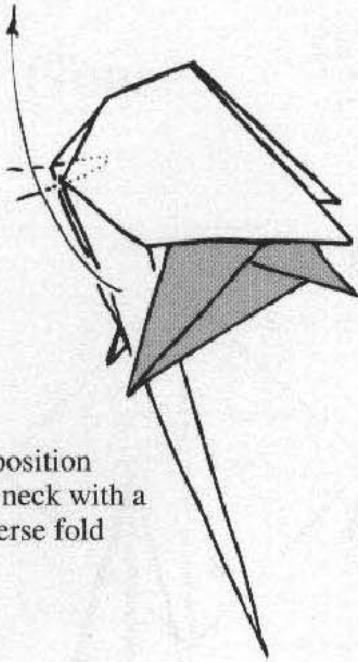

Reposition the neck with a reverse fold

19

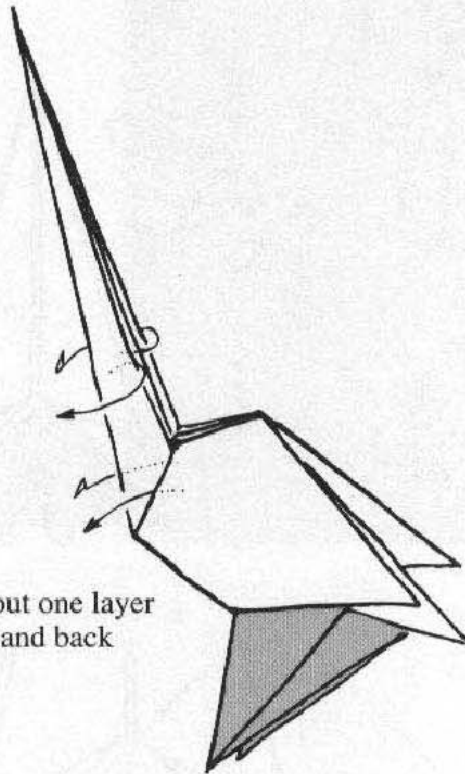

Pull out one layer front and back

20

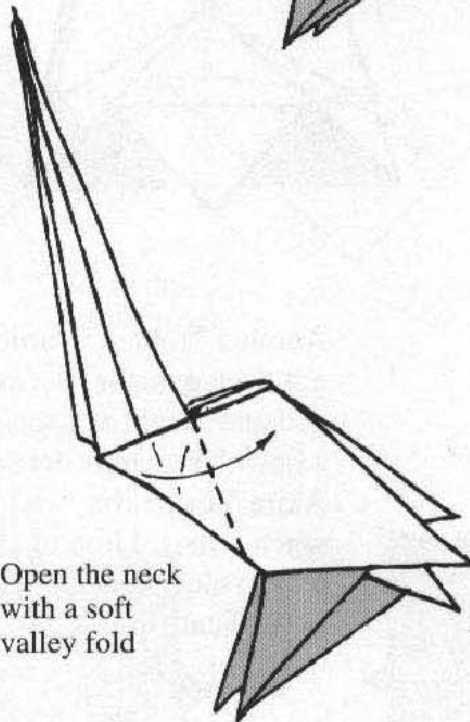

Open the neck with a soft valley fold

24

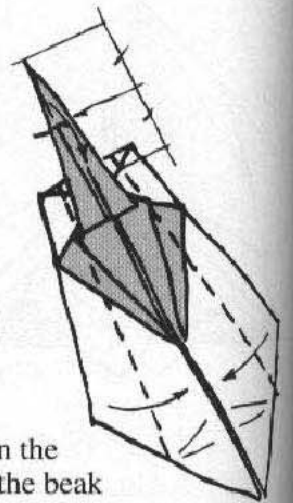

Fold in the tip of the beak then narrow the neck

21

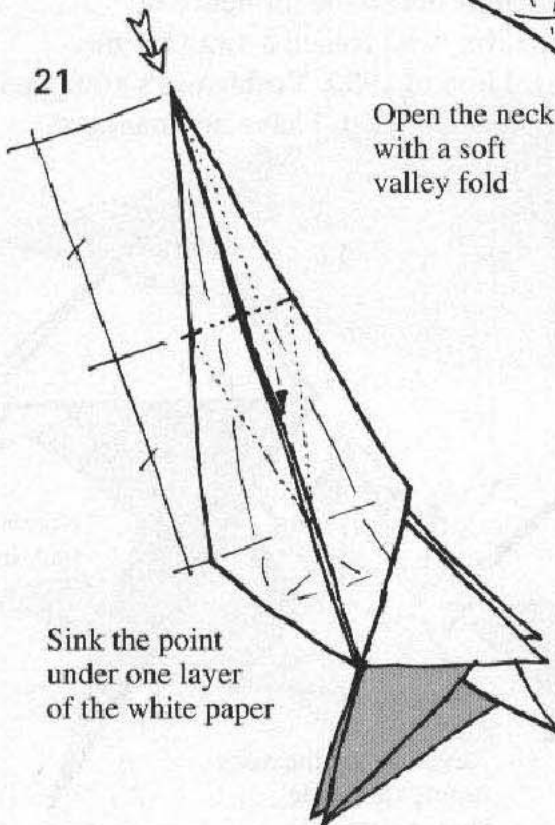

Sink the point under one layer of the white paper

23

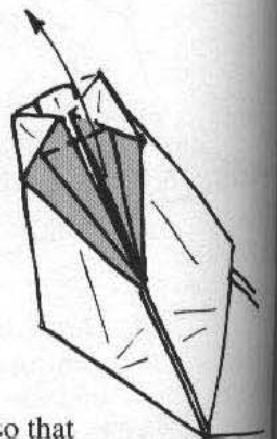

Squash each flap so that the outside edge of the squash lies along the edge of the neck (see 23)

22

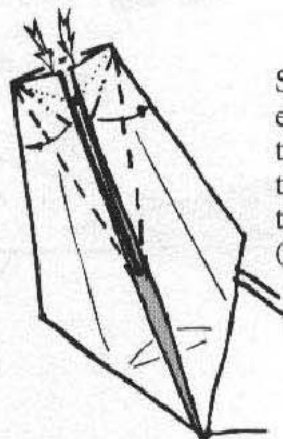

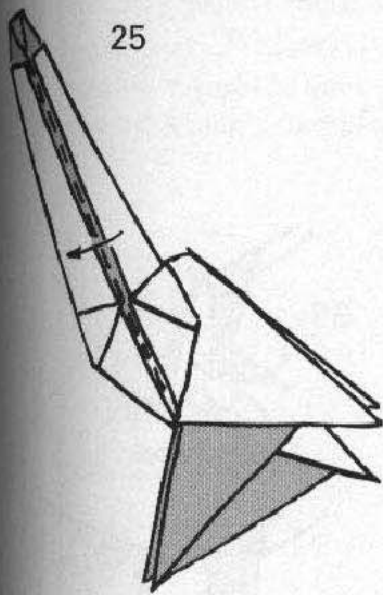

25

26

Outside reverse fold

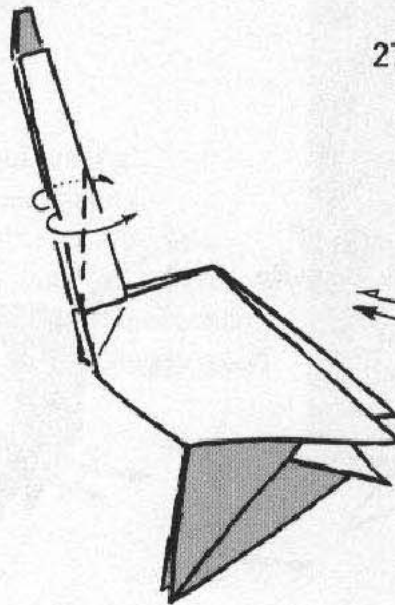

27

Carefully push in the back and the layer at the base of the tail

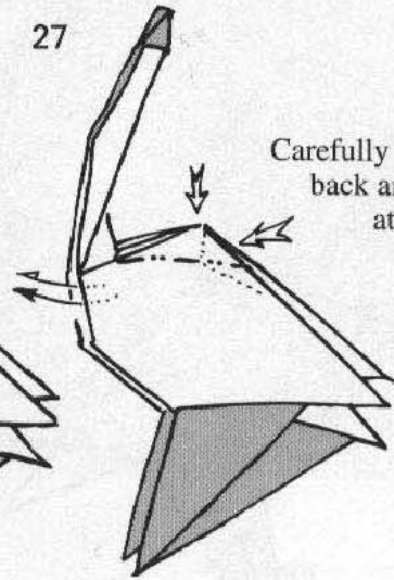

28



Shape the beak and the top of the head and partially release layers within the head to make a rounded head

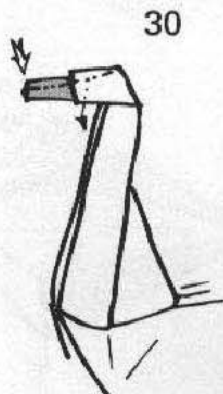

30

29

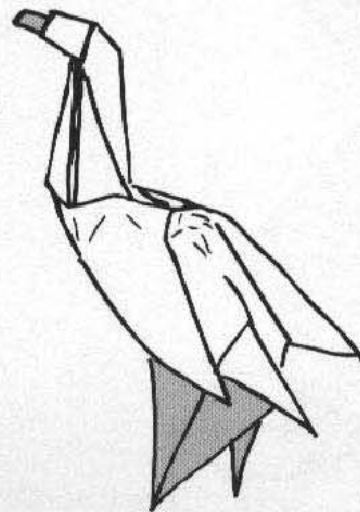

31

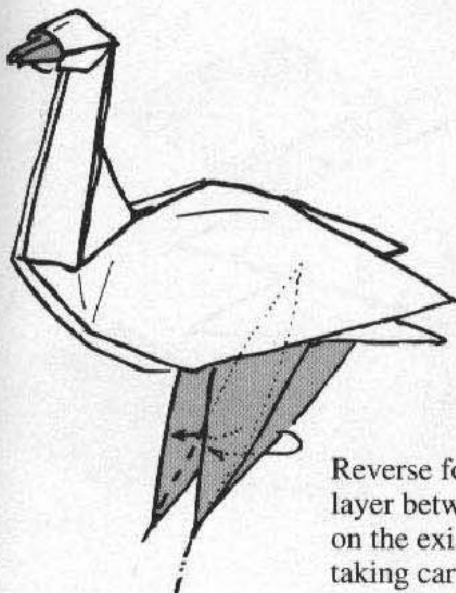

Reverse fold the layer between the legs on the existing crease taking care not to flatten the model.

32

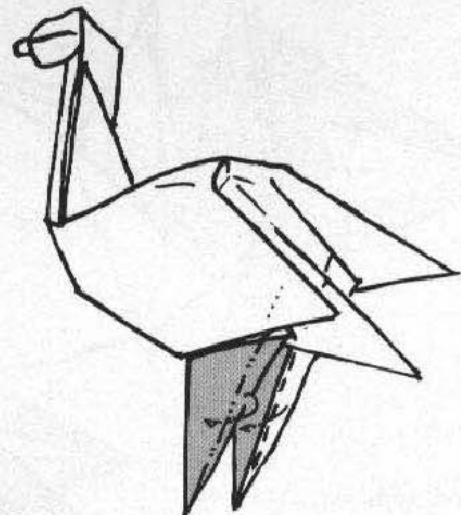

Narrow the outside layers of each leg to match the layer behind, and tuck inside each leg

33

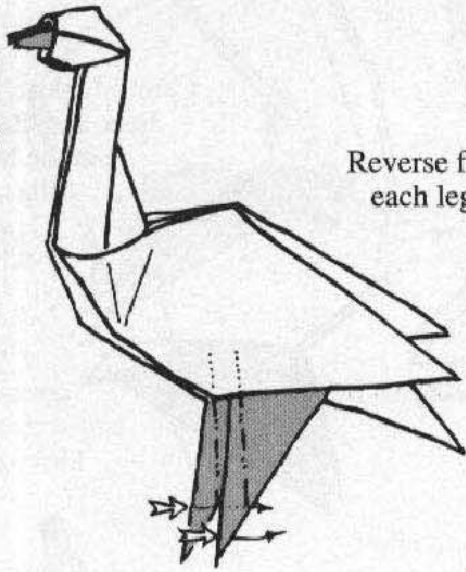

Reverse fold
each leg twice

34

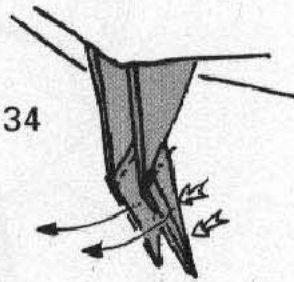

35

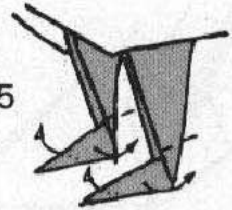

Then open

37

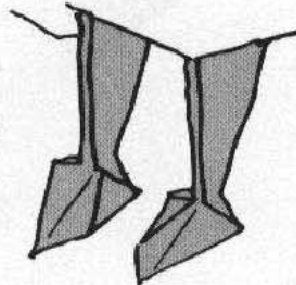

36

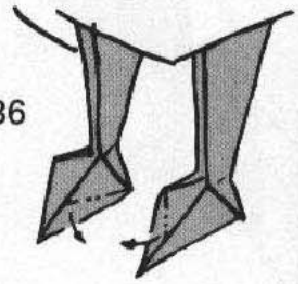

Pull out
one layer
to suggest
webbed feet

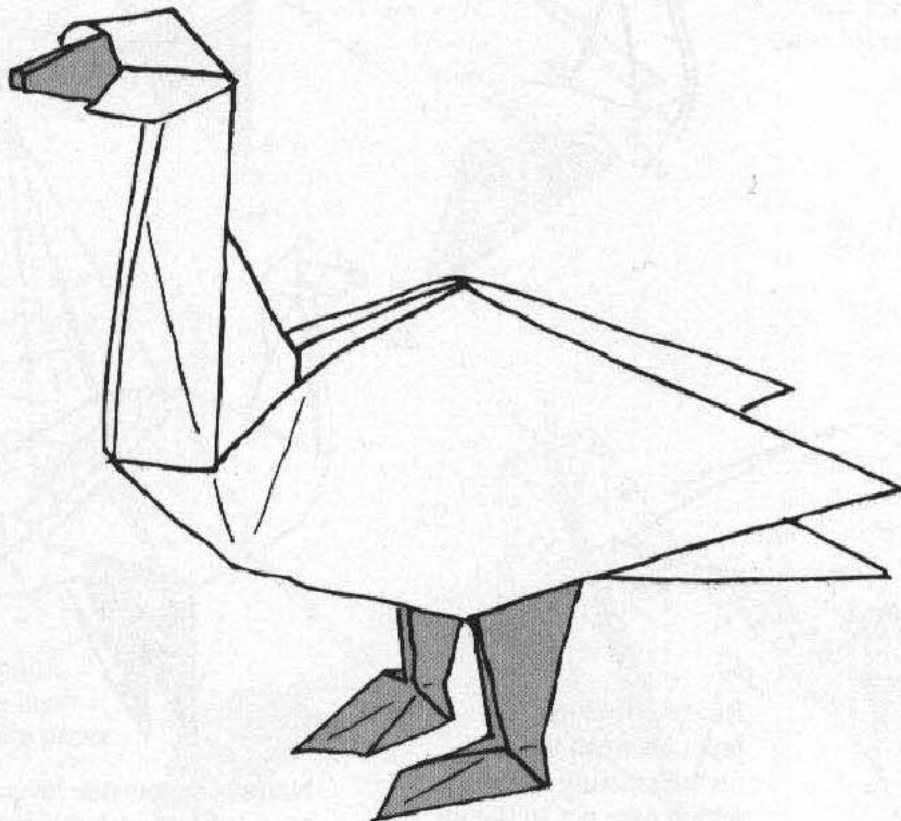

Squirrel

A development of the mouse/guinea pig: the formation of the head and ears needs care, but if done successfully gives a dramatic move in 26. Further difficulties may emerge in the shaping of the back of the head but a second or third attempt should allow you to obtain a good result.

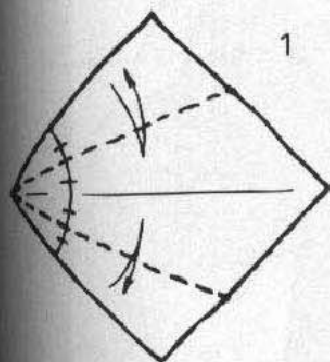
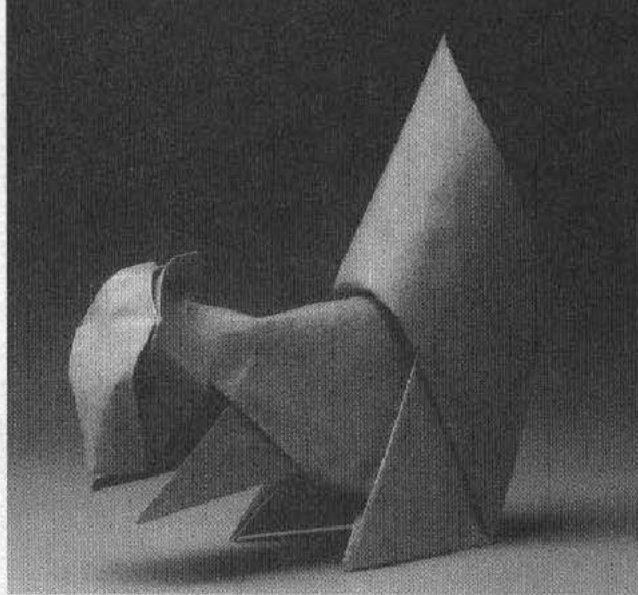

1

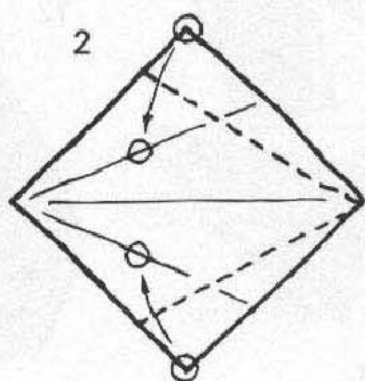

2

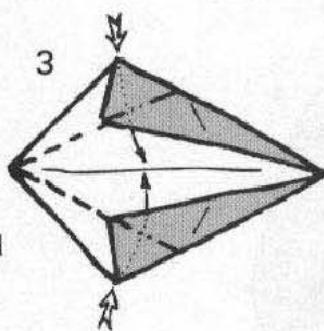

Reverse fold

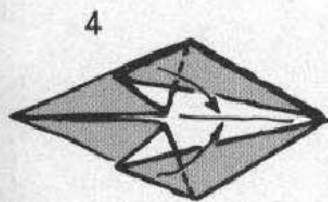

4

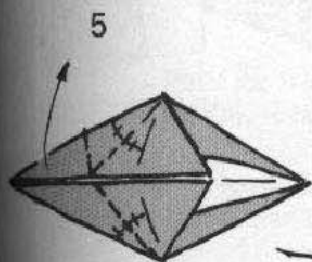

5

Make a rabbit ear

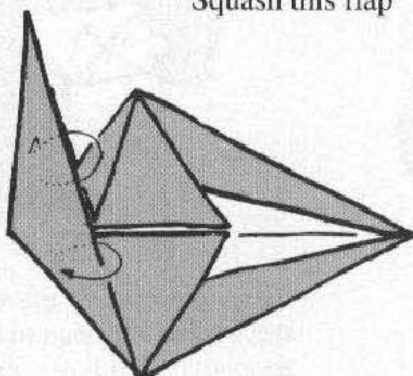

6

Squash this flap

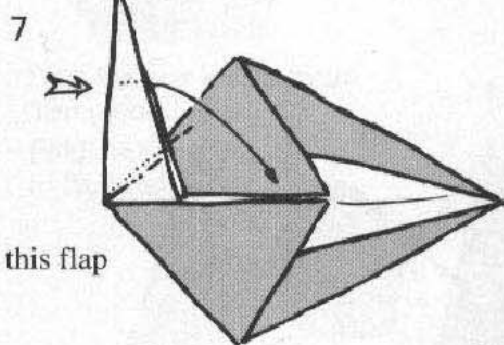

7

pull out layers from within the rabbit eared flap

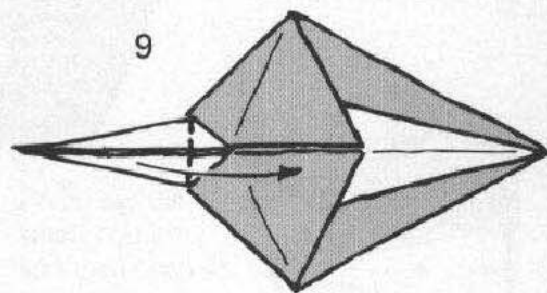

9

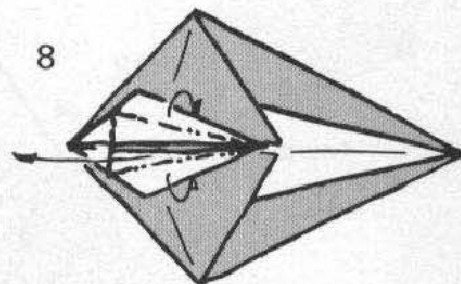

8

Make a petal fold on the white flap

10

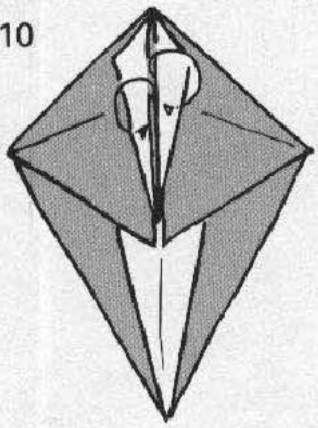

Turn the white layers inside out to make the flap coloured.

11

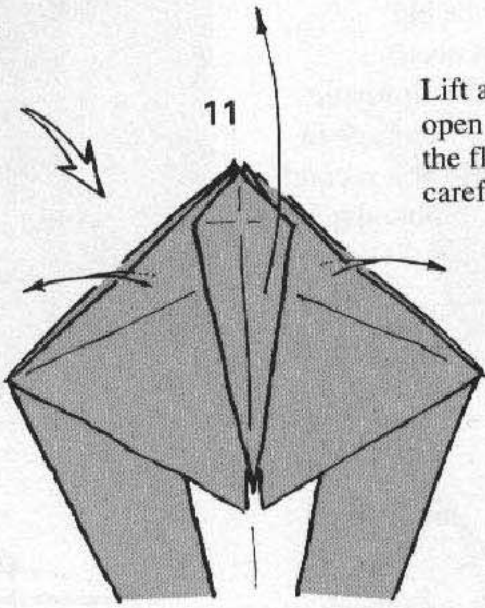

Lift and open up the flap carefully

12

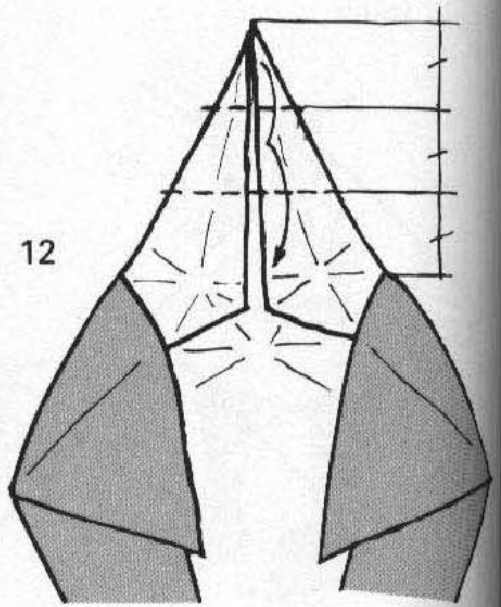

Reform the head section

13

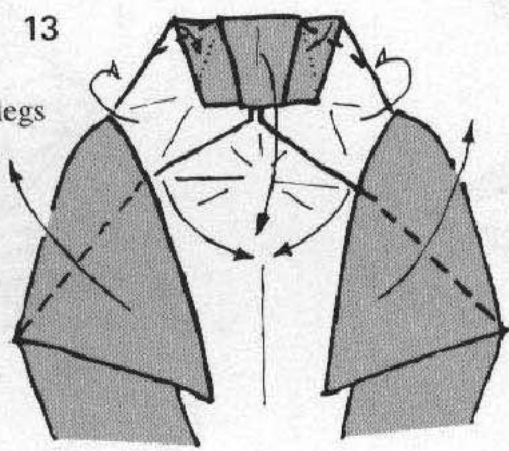

Lift the front legs

Shorten the tip by folding over and over in thirds

14

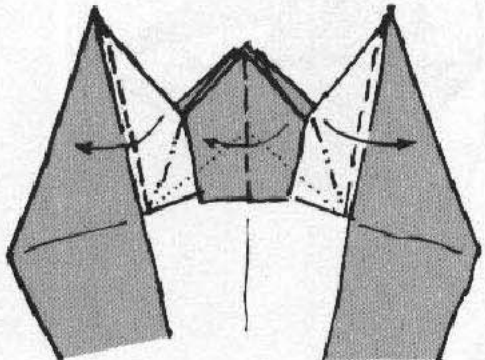

Narrow the front legs and fold the lead in half to the left.

15

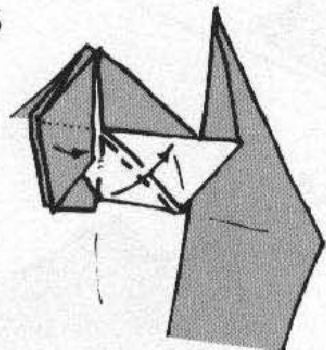

Lift and precrease the white layer as show: this causes the head to open slightly and the triangular area lying inside the head to stand vertically.

16

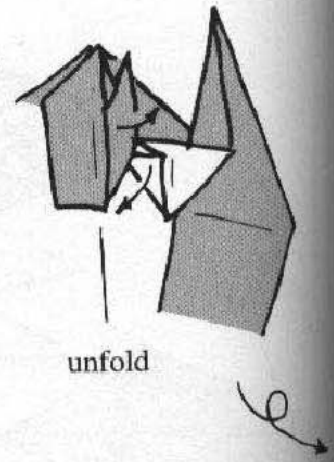

unfold

21

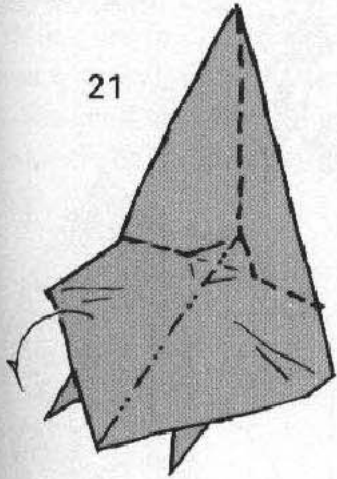

Reform the back and tail using new creases around the precreased diamond shape at the base of the tail

22

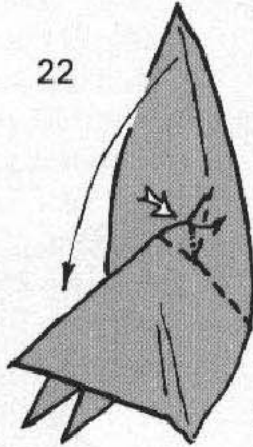

Push over the diamond shape and collapse the tail

23

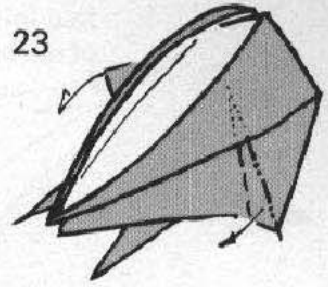

pleat the rear legs again

20

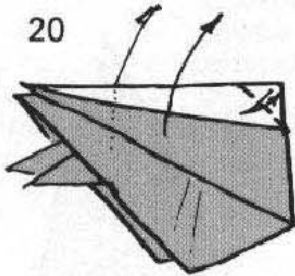

Precrease the small corner and then open up

19

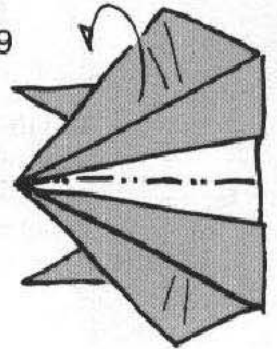

18

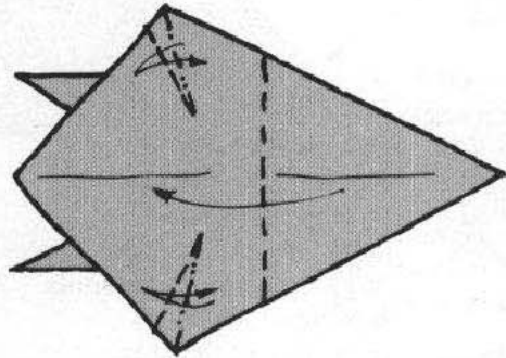

Pleat the rear legs forward then unfold.
Fold the tip of the tail to the head.

17

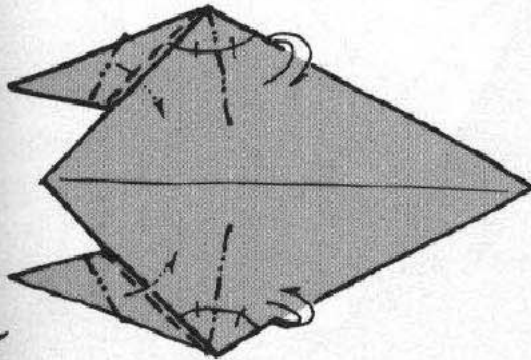

Pleat the front legs into the layers between the body.

Precrease the rear leg section noting that the crease does not extend to the centre line

24 Outside reverse fold the tail with a curved fold following the shape of the back

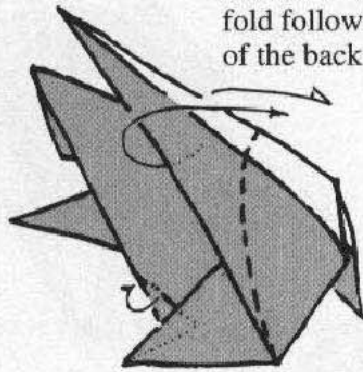

Narrow the belly-line to lock the rear legs

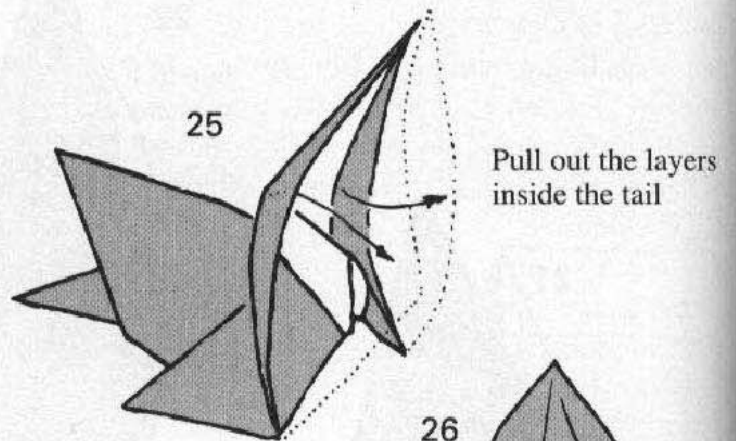

27 Lift the head further and soften the back by pushing in gently along the creases shown

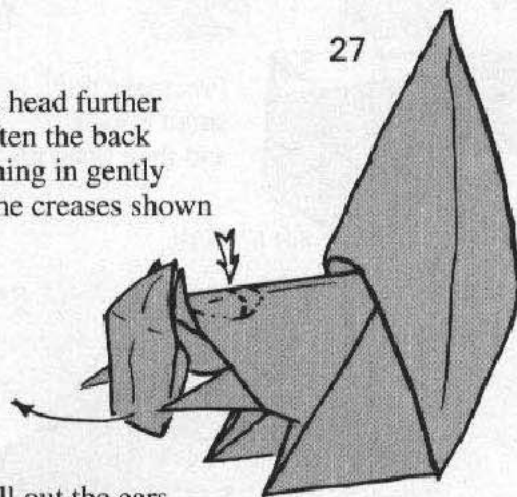

28 Pull out the ears. Shape the head and push in gently the point between the ears. Suggest an eye by carefully separating the layers at the side of the head

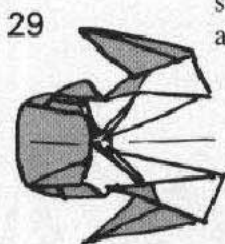
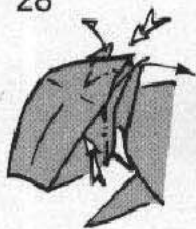

View from below showing the creases prepared in 15

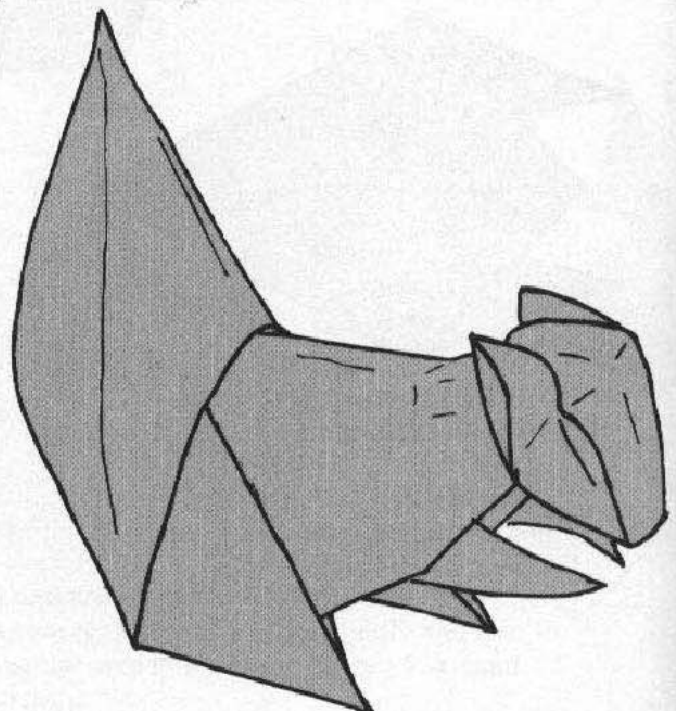

Foxhound

In my early creative experiences, the *blintz bird base seemed to be a saviour for all subjects. I had been deeply impressed by George Rhoad's Elephant in *The Best of Origami* by Sam Randlett, and had enjoyed reading a treatise on blintzes by Gershon Legman printed by Dokuohtei Nakano in his publication, *The Origami Companion*, in the 1970s. I later found the blintz to be more a hindrance than a help, producing models which are thick and uneconomical. This dog is however a successful treatment of half of a blintz bird base and was designed to complete the Fox Hunt scene with the two models on the following pages.

* see 8, p. 125.

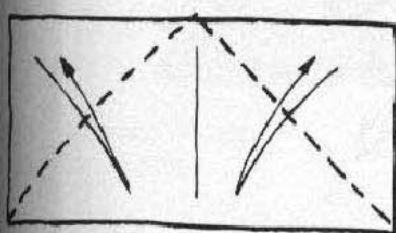

1

Start with a 2x1 rectangle
minimum size 8x4 inches (20x10 cm)

2

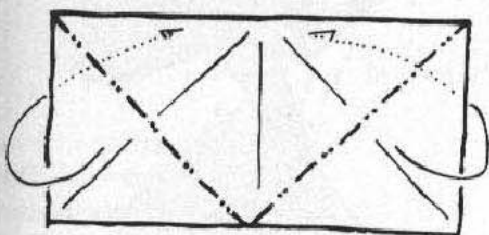

3

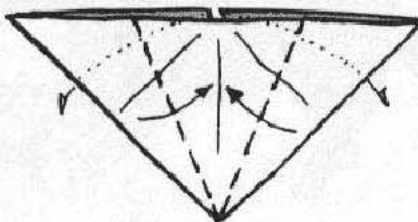

Allow the corners to come from behind

4

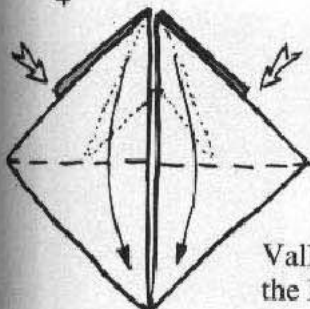

Valley and squash the layers behind

5

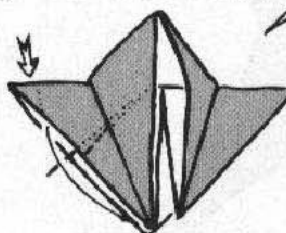

Reverse fold

Half of a Blintz Bird Base

6

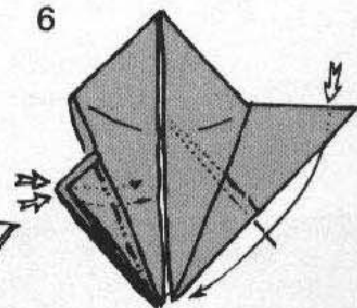

Sink the 2 corners on the left, & repeat 5 & 6 on the right

7



Valley fold the front legs to lie along the outside edges

8

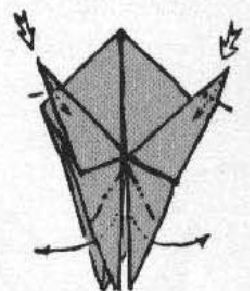

Reverse fold the back legs

9

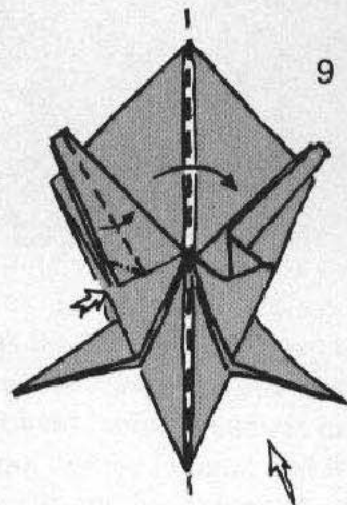

Narrow and squash the front legs

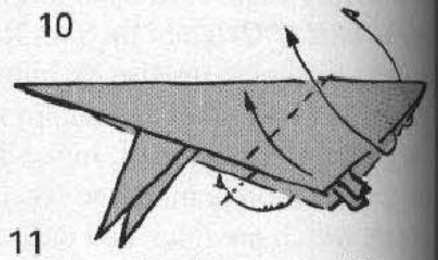
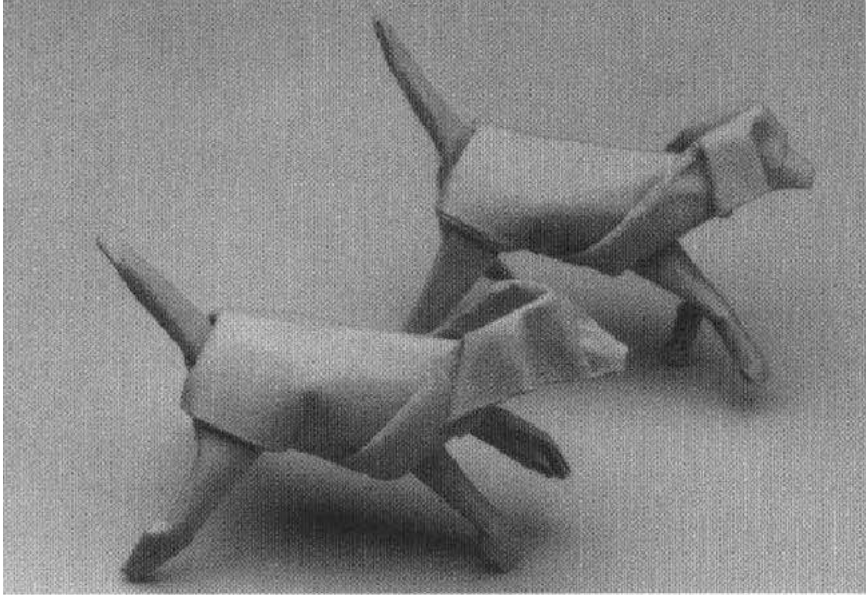

10

11

Outside reverse fold the head flap

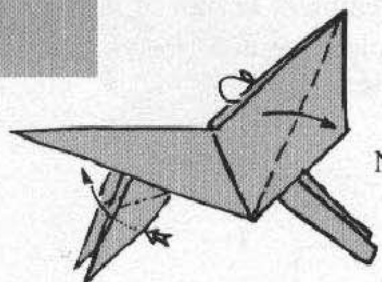

Narrow the neck

Reverse fold one back leg

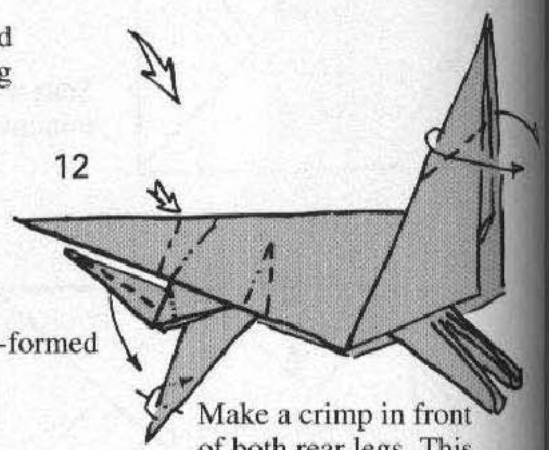

12

Reposition the rear leg in a partially-formed petal-fold

Make a crimp in front of both rear legs. This does not meet the centre-line, and makes the body 3D

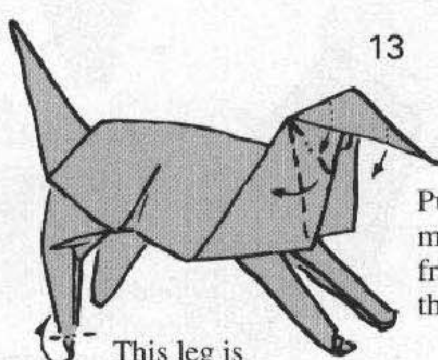

13

Pull out material from inside the head

This leg is not flattened

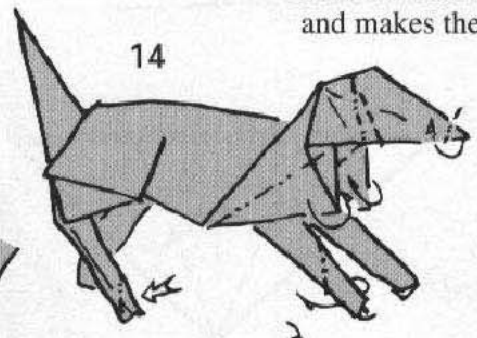

14

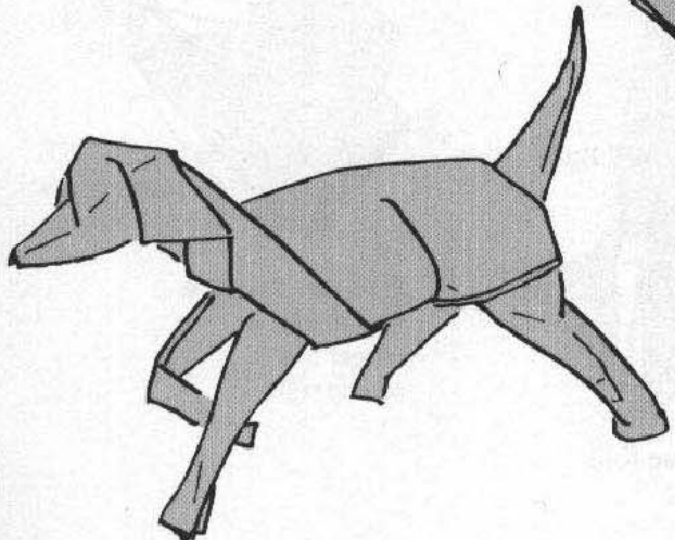

15

Finishing folds to complete the foxhound

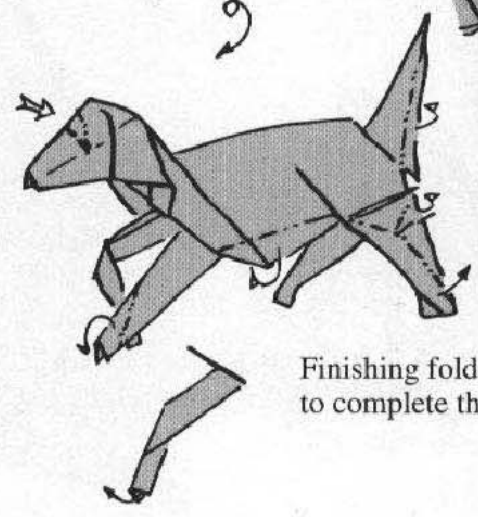

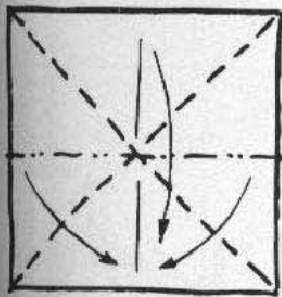

Fox

Make a waterbomb base

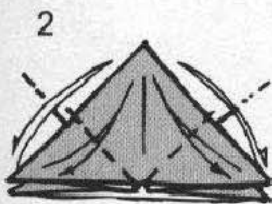

Pre-crease each corner to the central point

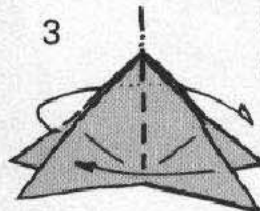

Rotate

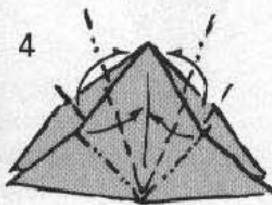

Lift the rear corner

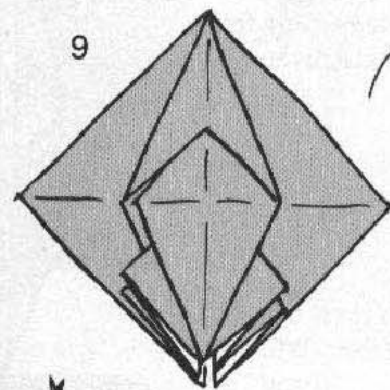

This shape is known as the *Blintz Bird Base*

Reverse fold two edges

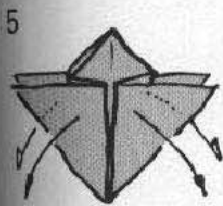

Open out completely to the coloured side

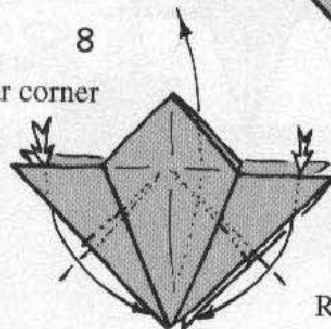

Bring the points together below

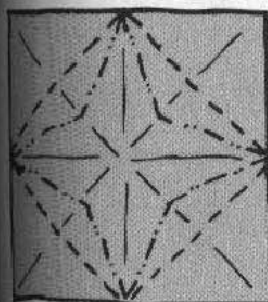

Re-form following these crease lines, at the same time lifting each corner

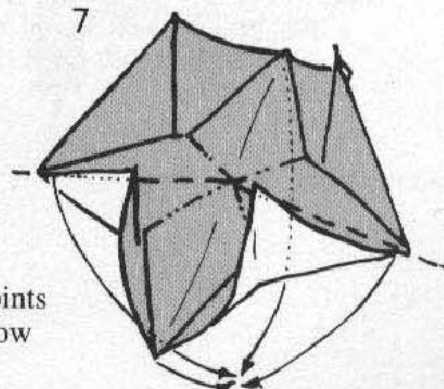

One of the first animals I made with the blintz bird base is this Fox. I was forced into using the twisted head as the ear flaps emerged under the head. This idea was later more successfully developed into forward facing creatures in the Elephant and Rhino, but the Dragon and Rabbit use similar techniques and look sideways or backwards. In the context of the Foxhunt scene, the head posture of the fox fits well.

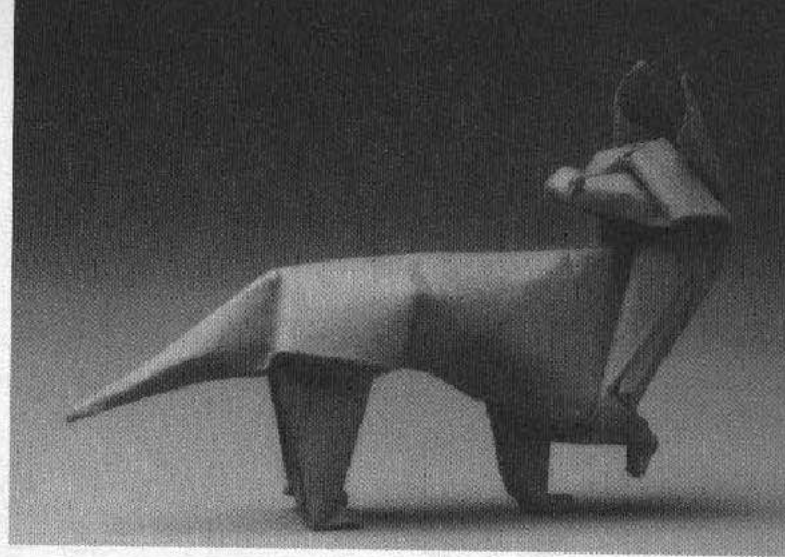

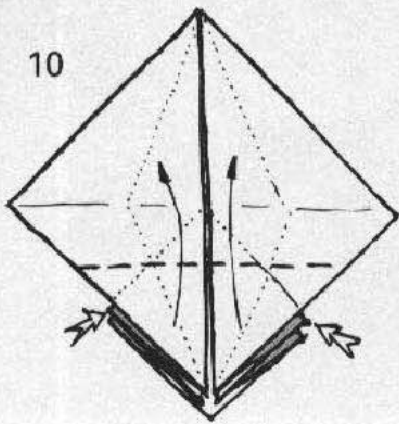

10
Lift and petal-fold
2 corners, noting the
position of the
horizontal valley fold

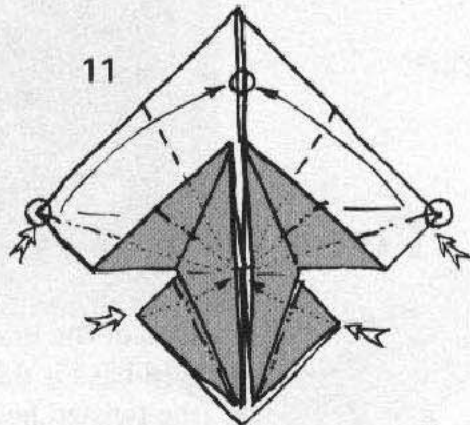

11
Reverse fold 4 times

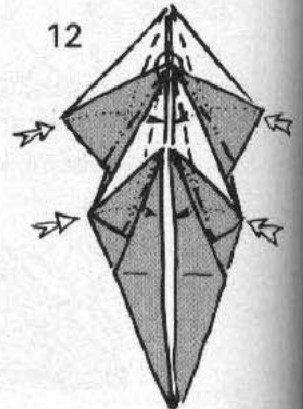

12
4 more reverse folds

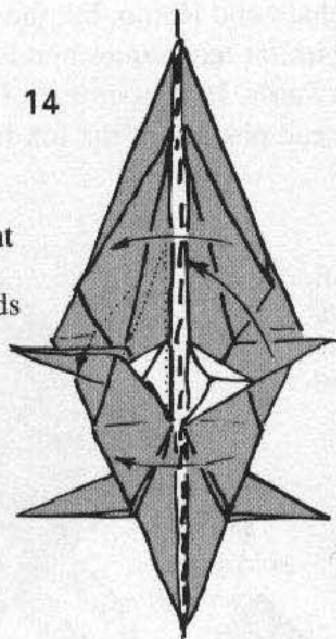

14
Change the front
leg valley folds
into reverse folds



Fold the body in half

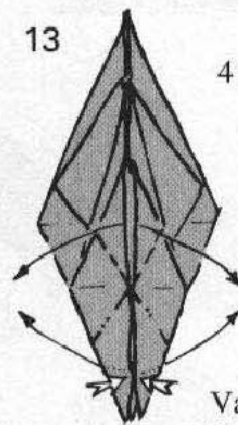

13
Note the white
triangular squashed
area at the base of
front legs

Valley fold
the front legs
and reverse fold
the rear legs

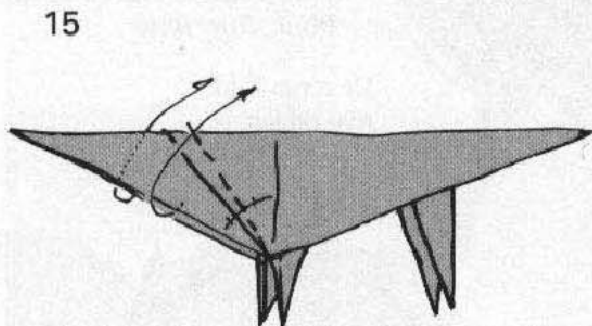

15
Outside reverse fold the neck

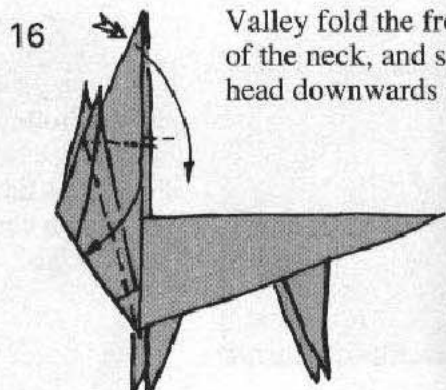

16
Valley fold the front layer
of the neck, and squash the
head downwards

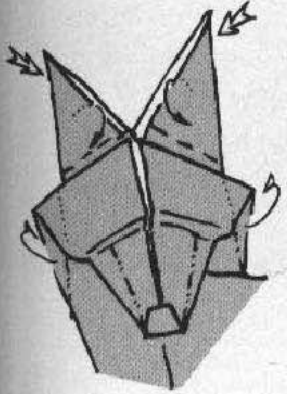

20

Shaping of the head neck and ears

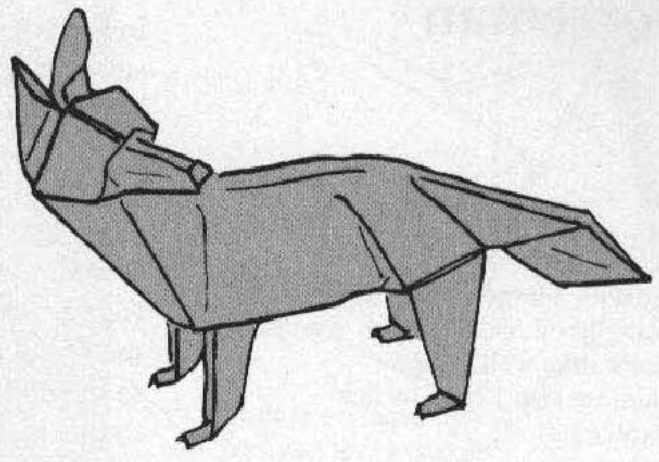

19

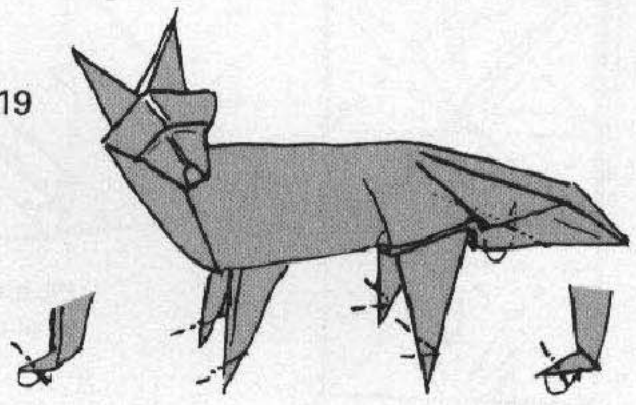

18

Shape the head with a pleat, and roll the point over to make the nose

Lift one layer either side of the tail to make the "brush"

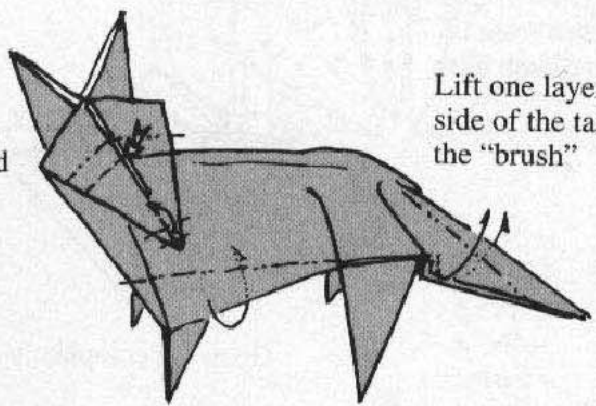

17

Trim the belly line with a mountain fold: this locks the rear legs

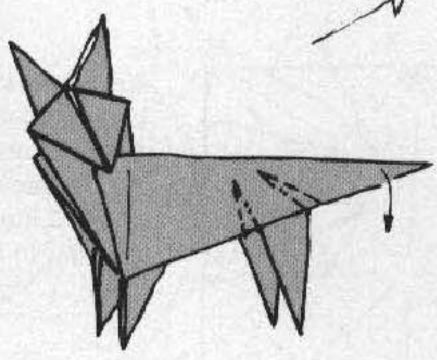

Make small pleats (not extending to the centre line) either side of the rear legs. The tail will move down

Horseman

Start with a large 2x1 rectangle coloured both sides: brown wrapping paper works well.
Minimum size 12x24 inches (30x60 cms)

In the 60s and 70s it was fashionable to make dual subject models such as this. The style was pioneered by US folders Neal Elias and Fred Rohm. Although this horse and rider is presentable, it has many unsatisfactory aspects such as the white rear legs and tail if the design is made from coloured/white paper. It is also excessively bulky and has a very longwinded folding sequence. Following other dabblings with the multi subject style, I decided that the compromises to the individual parts were too great. I now prefer to make each subject from a separate sheet. To paraphrase Akira Yoshizawa, the man and the horse exist separately in nature, so why should we seek to join them?

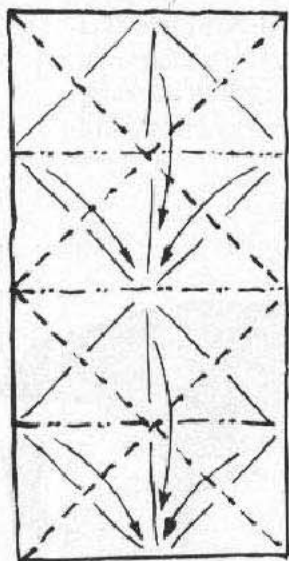

Precrease diagonals verticals and horizontals as shown, then form into a double waterbomb base

1

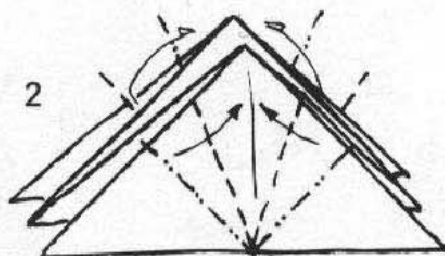

Pleat to the centre line front and back

2

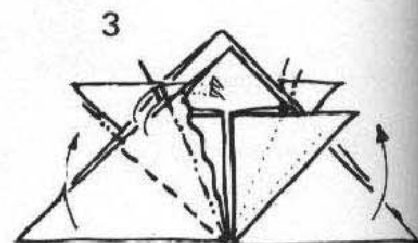

Crimp the centre points between the layers

3

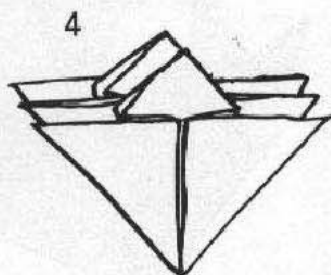

Open out completely

4

5

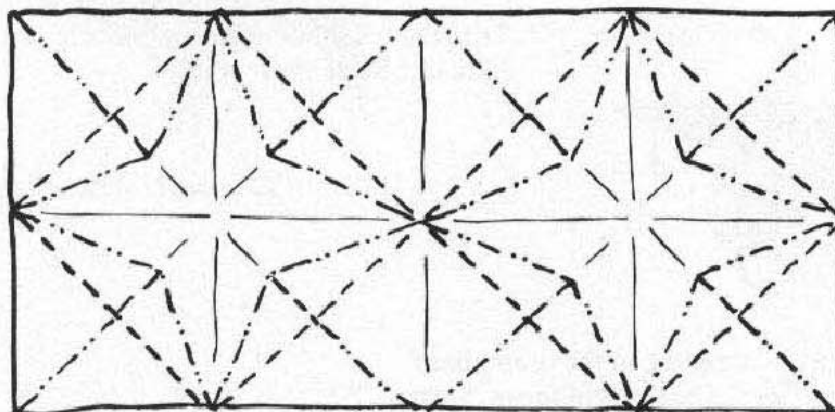

Reform the existing creases like this, then collapse by lifting each corner and the centre of the 2 long sides. (similar to Fox, step 7)

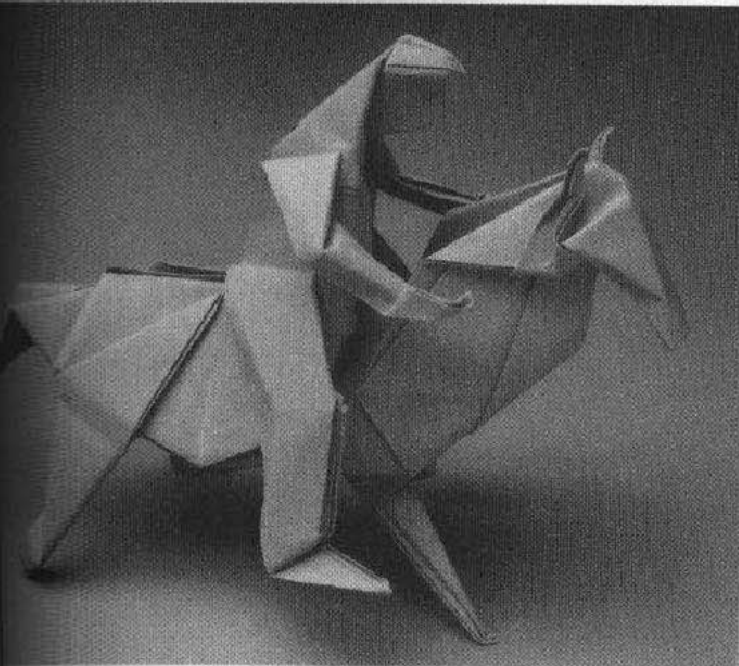

11

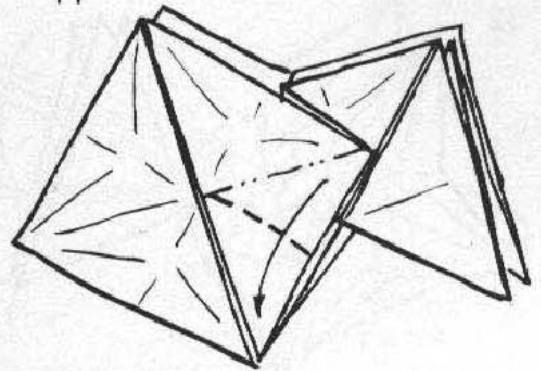

Start to collapse by forming these creases

10

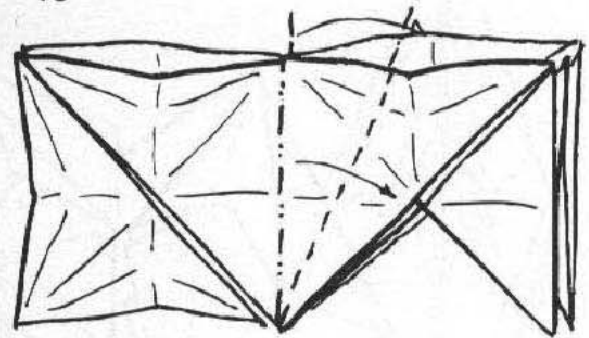

Pleat front and back

9

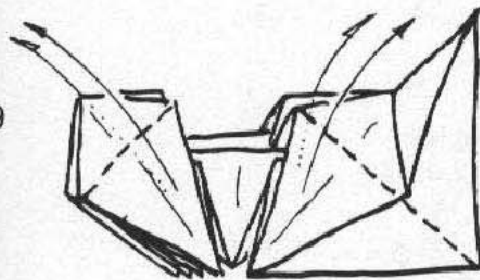

Open up front and back

8

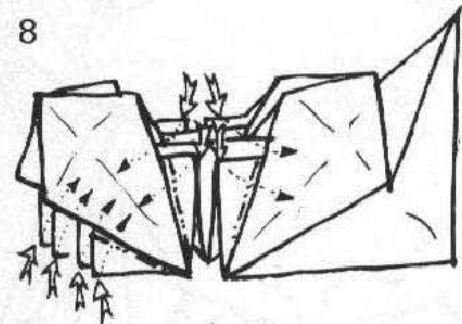

Reverse fold 8 right-angled corners

Lift the hidden corner

7

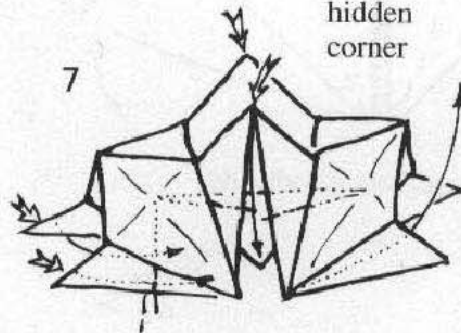

Reverse fold 4 times
This is a double Blintz Bird Base.

6

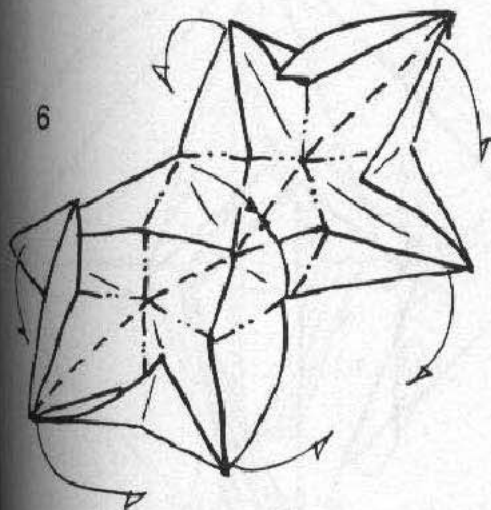

Bring six corners together

12

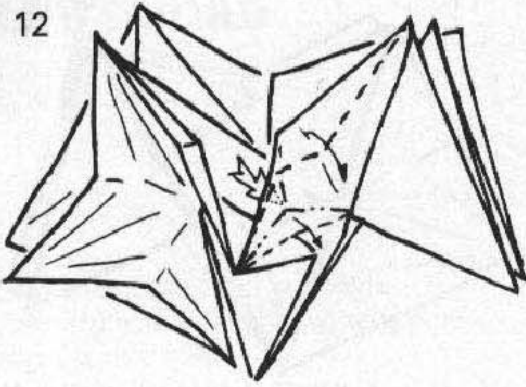

Push in gently reforming the creases as shown, and continue collapsing the left and right sides of the construction

13

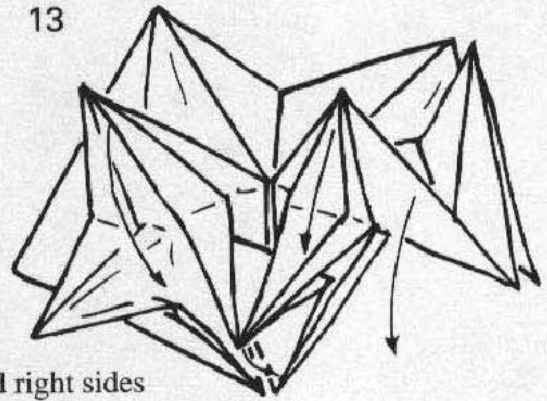

14

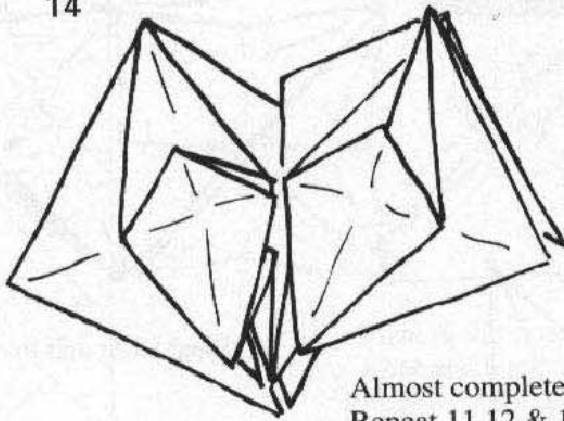

Almost complete
Repeat 11,12 & 13
on the back

15

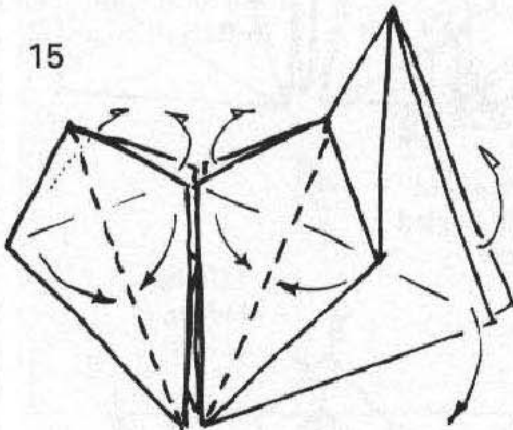

Open and rotate both sides

16

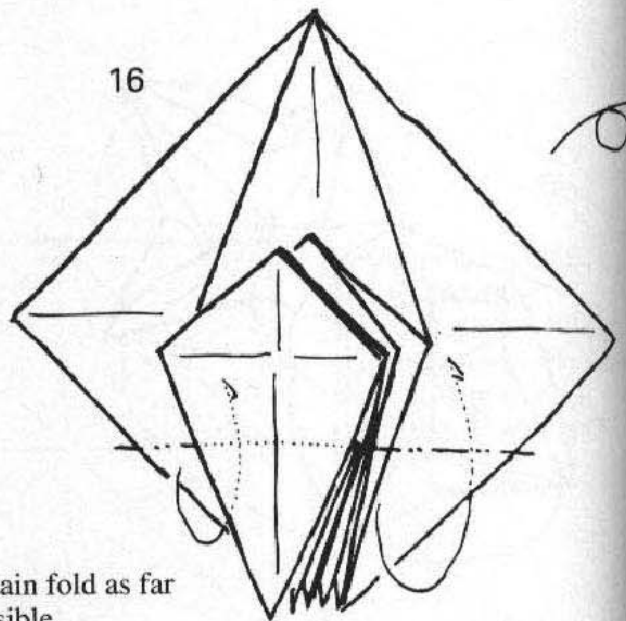

Mountain fold as far as possible

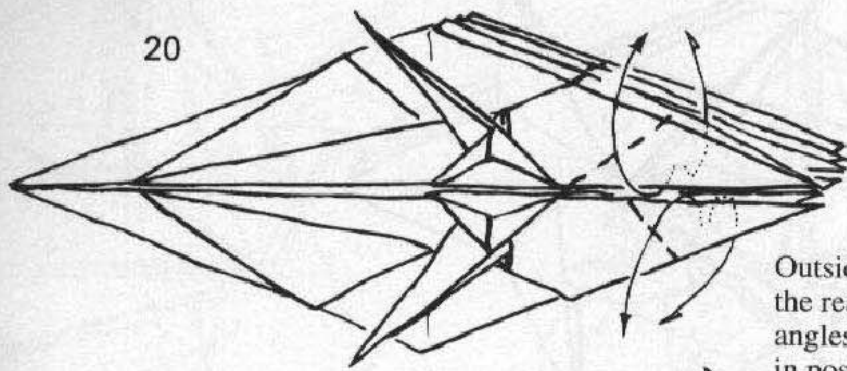

20

Outside reverse fold
the rear legs at different
angles, leaving the tail
in position

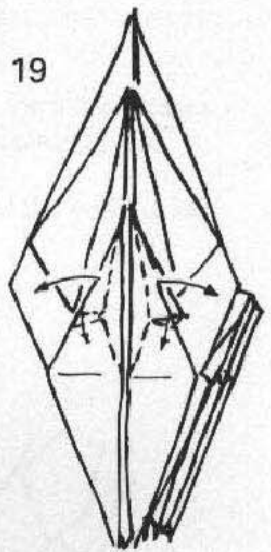

19

Narrow the
front legs
with rabbit ears

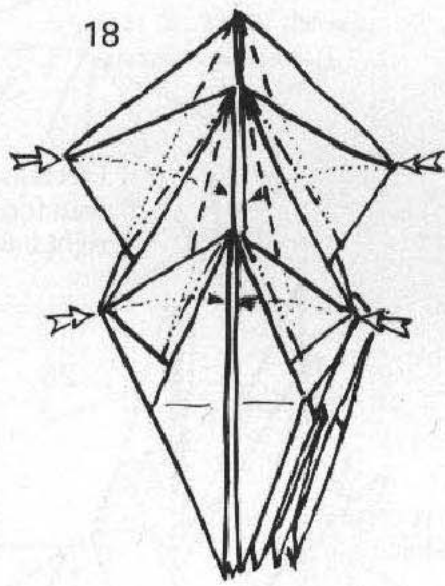

18

4 Reverse folds

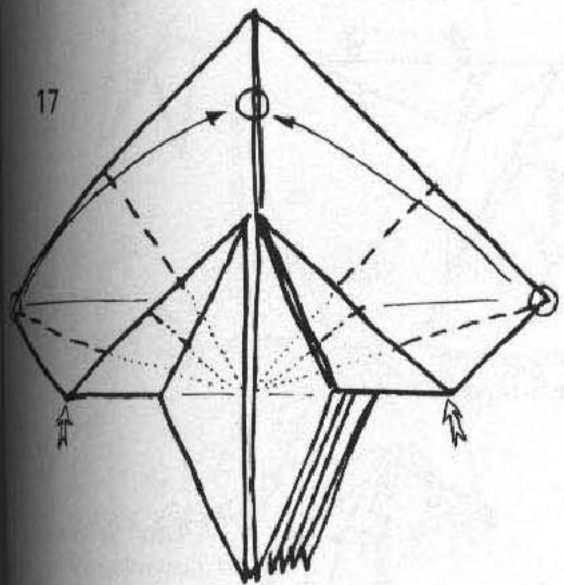

17

Reverse folds to form an
asymmetric preliminary base

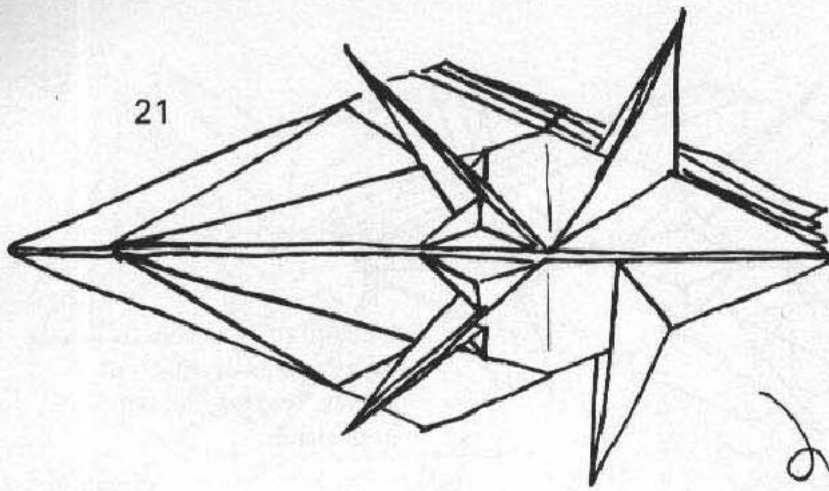

21

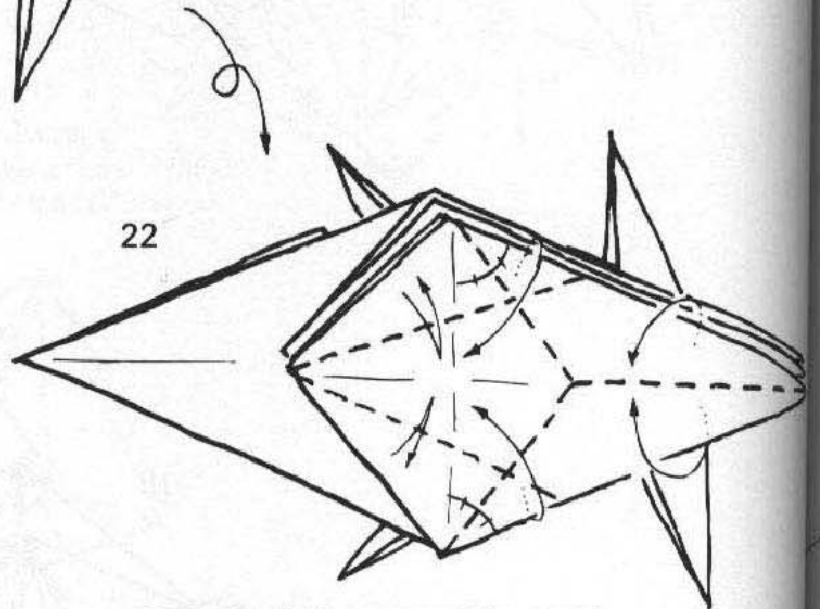

22

Precrease in the centre of the model then form the uppermost 5 flaps on the right into a rabbit ear

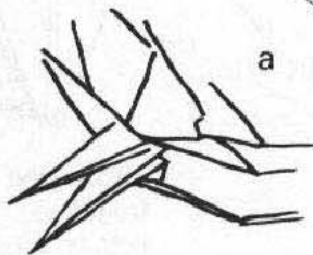

a

Shows the lower corner of the belly sunk between the layers

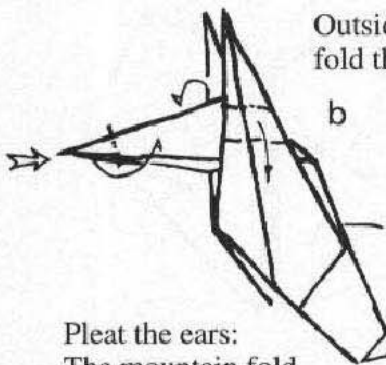

Outside reverse fold the head

b

Pleat the ears: The mountain fold should coincide with the lower edge of the head (see c)

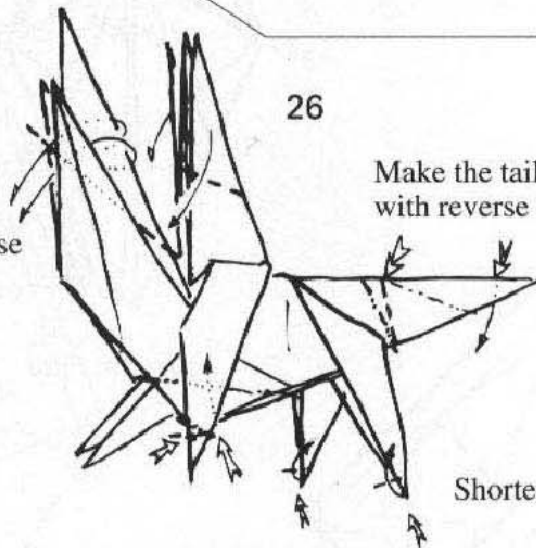

26

Form the rider's feet, and sink the corner behind (see a)

Make the tail with reverse folds

Shorten the feet

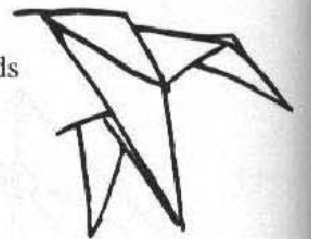

f

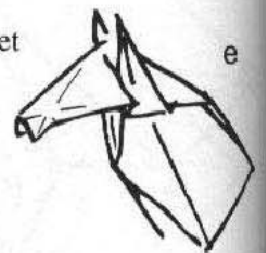

e

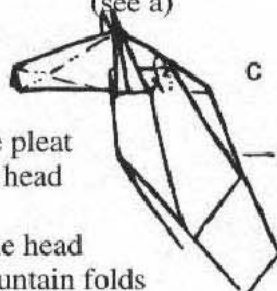

c

Tuck the pleat into the head

Shape the head with mountain folds

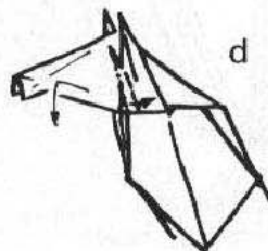

d

Crimp the head downwards

23

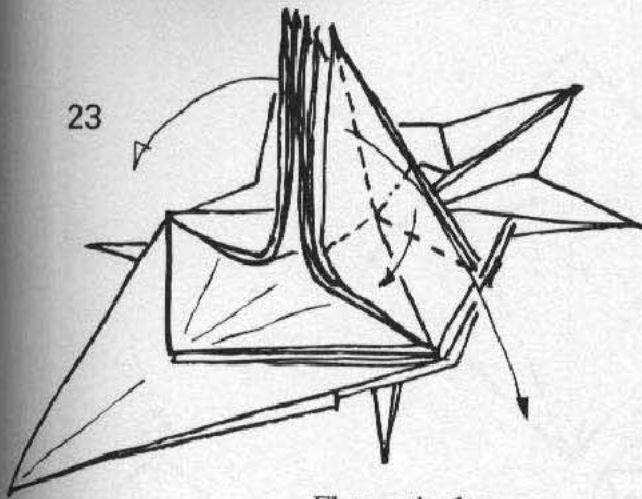

Flatten the legs
left and right

24

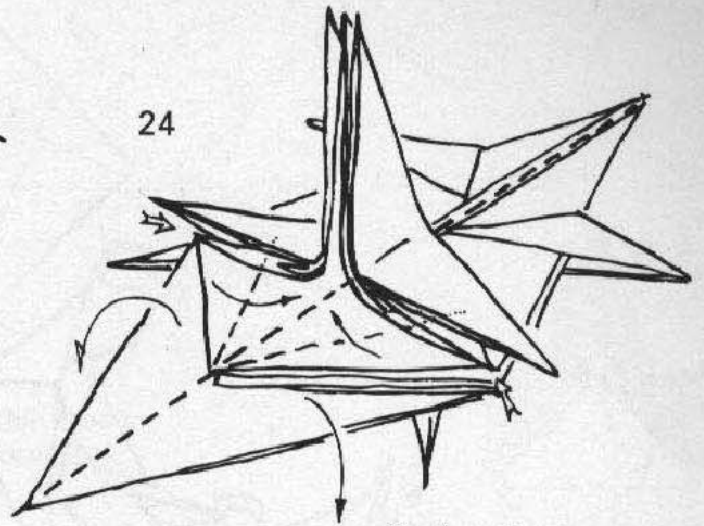

Re-form the creases
precreased in 22

Fold the body in half

25

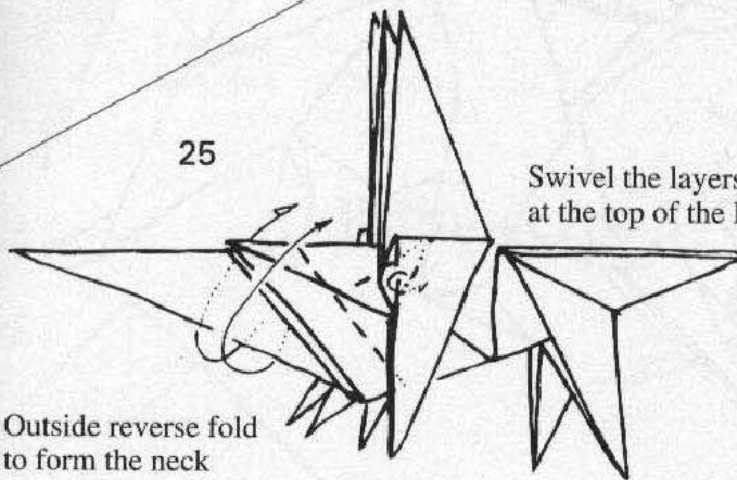

Swivel the layers
at the top of the legs

Outside reverse fold
to form the neck

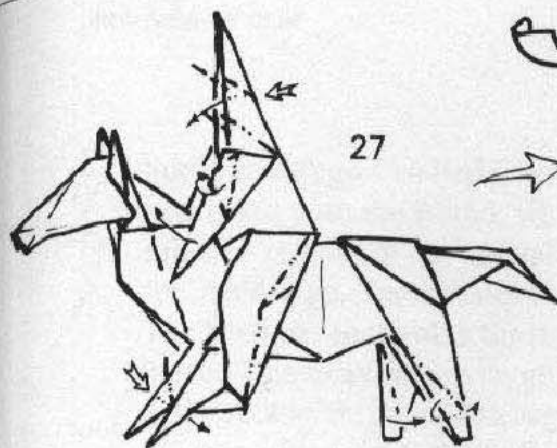

Formation of limbs
head and body

a



Pleat the hands

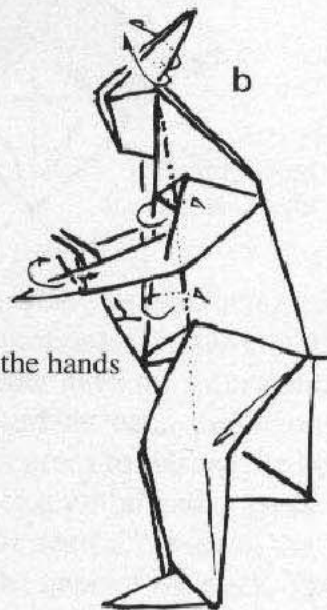

Narrow the rider's
chest and belly
with mountain folds

c



d



e

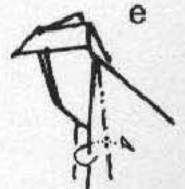

Formation of
head and hat

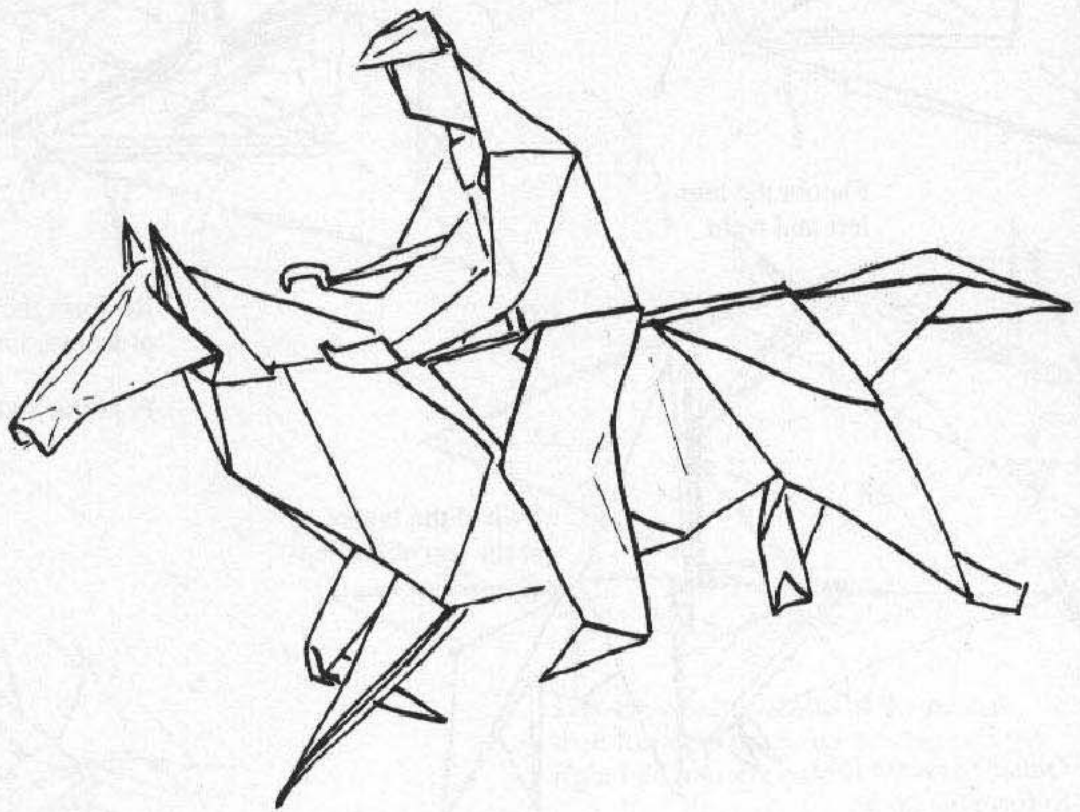

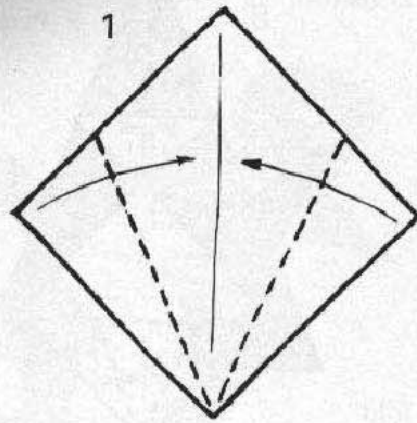

Use a large square: Thin brown wrapping paper works well

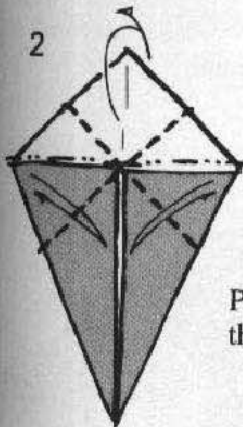

Precrease then open

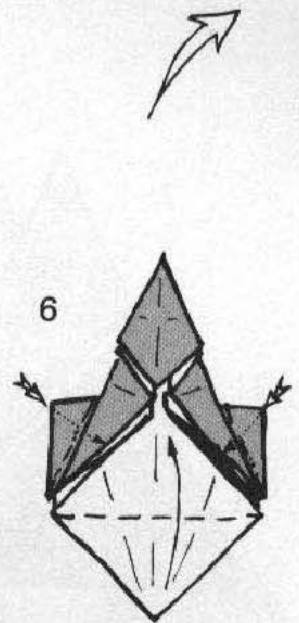

Rhinoceros

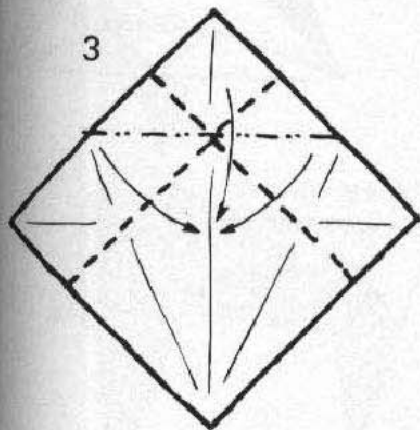

Form an off-centre preliminary base

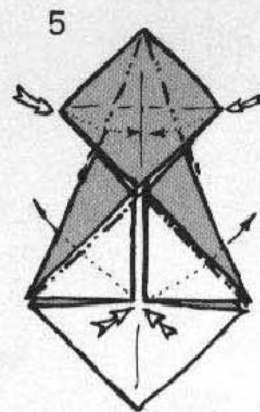

4 Reverse folds

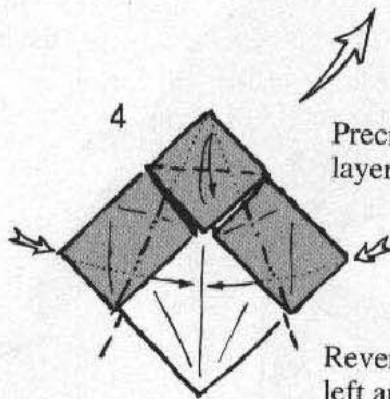

Precrease on one layer only

Reverse fold left and right

Some years ago I visited Chester Zoo, where I recall being very impressed with the Rhino, who stood motionless in his enclosure. I made sketches of the animal which later gave me information for this design. Technically the base used has been stimulating for me. The head has to revolve through 180 degrees to release the head and horns. This time, however, unlike the fox, rabbit and dragon, the animal looks forward, although this has been achieved at the expense of quite a lot of bulkiness at the nape of the neck. The stresses in the paper here can be used to pose the head slightly to one side, as if the Rhino is considering whether to charge at the spectator!

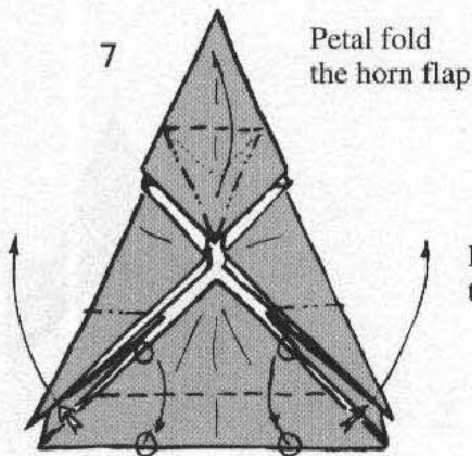

7

Petal fold the horn flap

Valley fold the tail flap noting the reference point

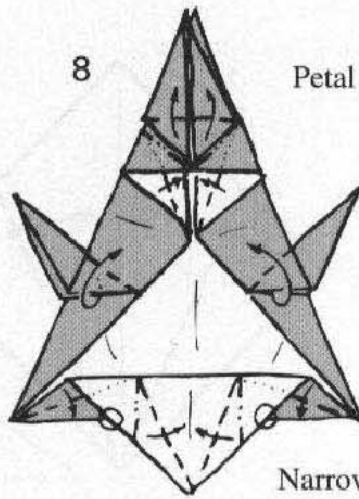

8

Petal fold the ears

Re-position the front legs

Narrow the tail

Reverse fold the front legs

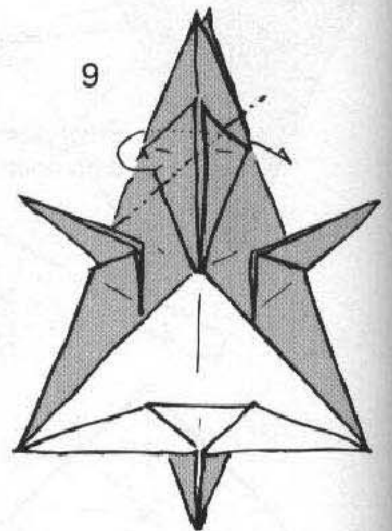

9

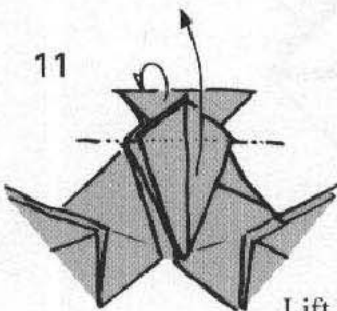

11

Lift the head allowing the ears to go behind

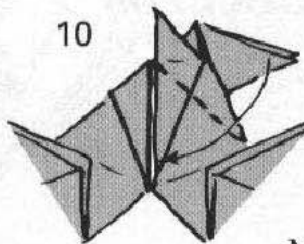

10

Make 2 folds to revolve the head and expose the ears

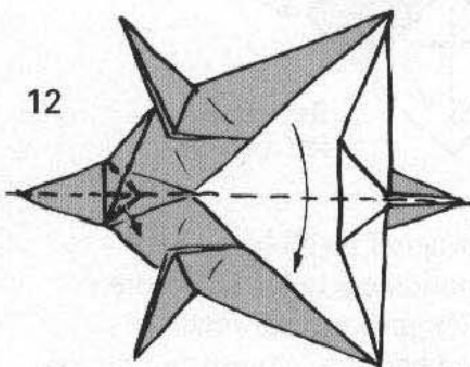

12

Valley fold the body in half, simultaneously reverse folding the small thick triangle as shown

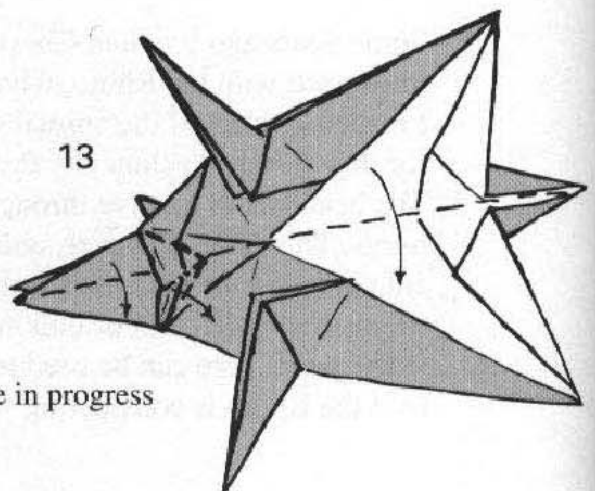

13

Move in progress

These drawings show the formation of the front and back legs

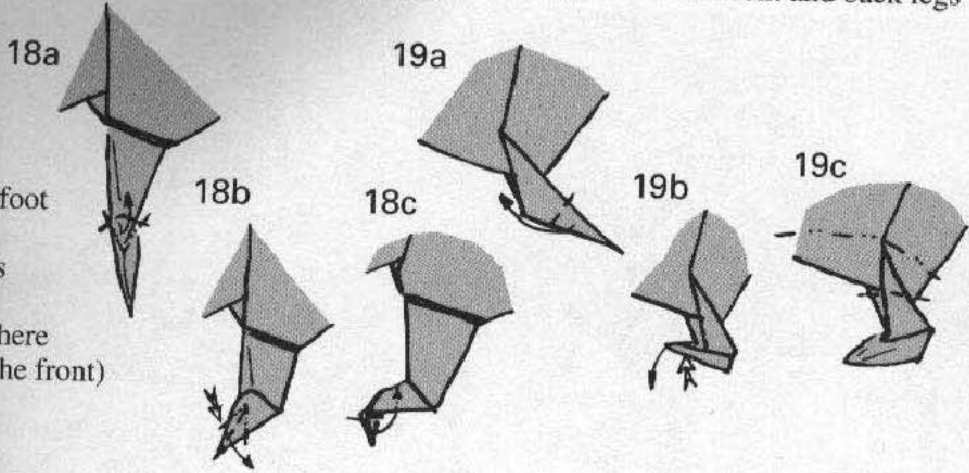

Crimp the foot upwards.
(these folds are shown in step 17, here seen from the front)

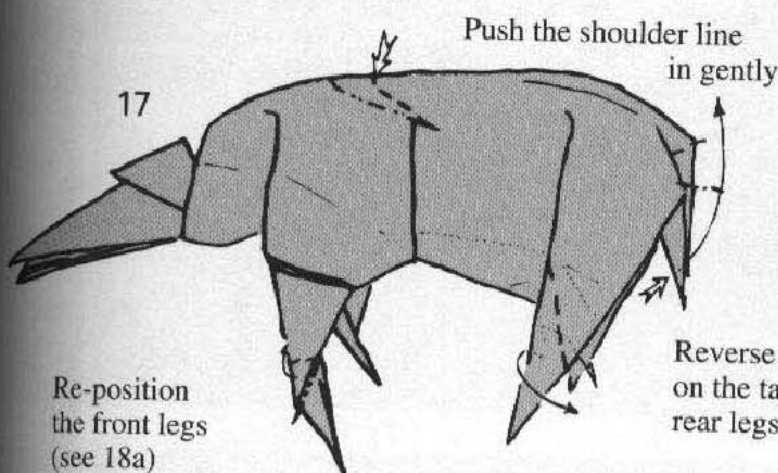

Re-position the front legs (see 18a)

Push the shoulder line in gently

Reverse folds on the tail and rear legs

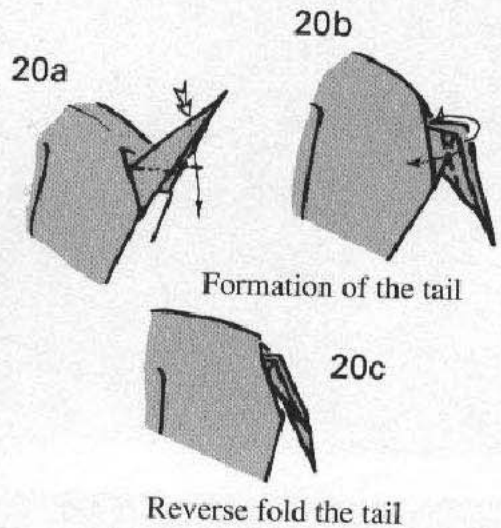

Formation of the tail

Reverse fold the tail

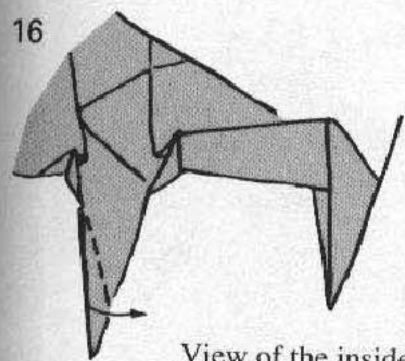

View of the inside showing the locked crimps

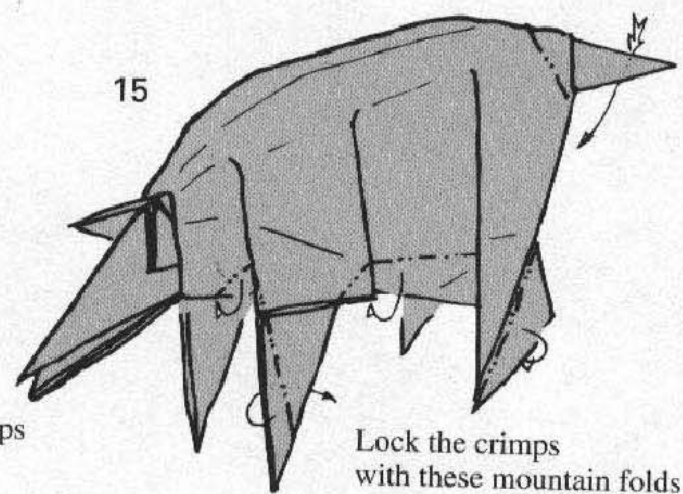

Lock the crimps with these mountain folds

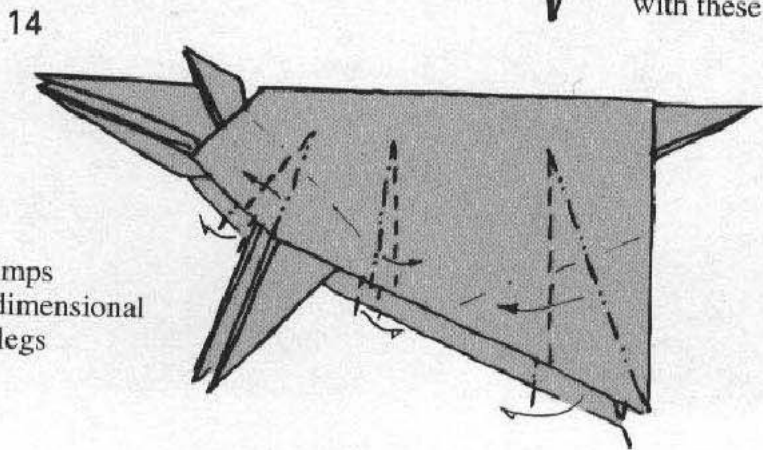

These 3 sets of crimps make the body 3-dimensional and form the rear legs

21a

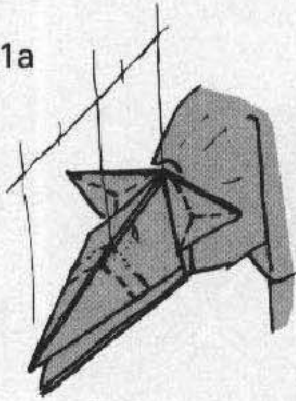

Pleat the smaller horn

21b

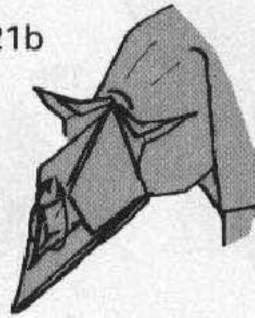

Raise the smaller horn with a rabbit ear

Pull out layers from within the smaller horn

21c

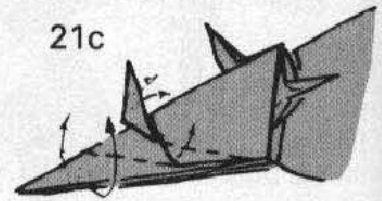

Valley fold the corner to make the eye

Outside reverse fold the larger horn

21d

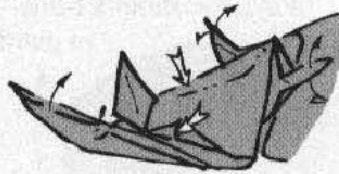

Open the ears, shape the head and eyes, and crimp the larger horn slightly

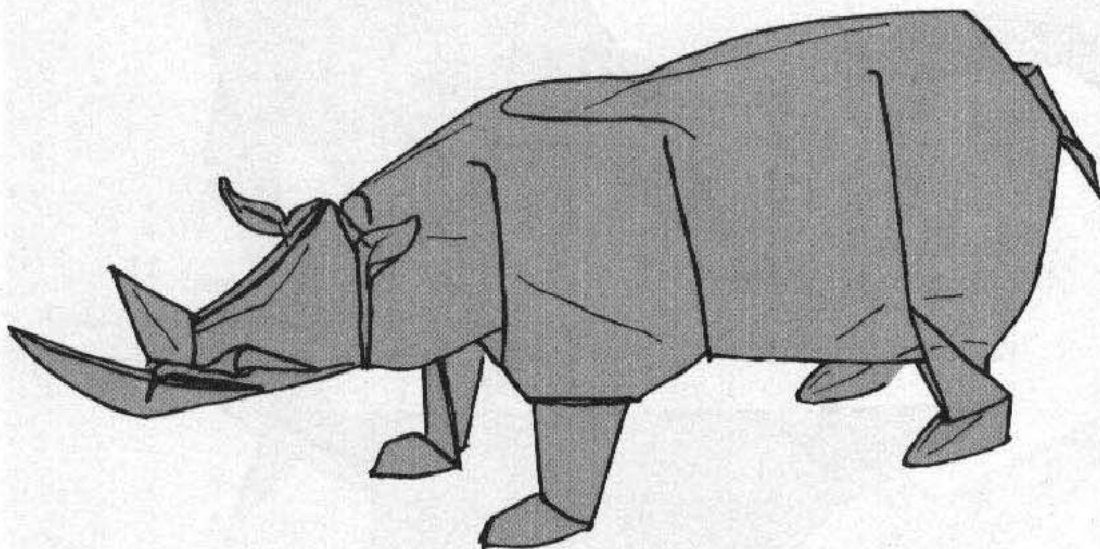

er

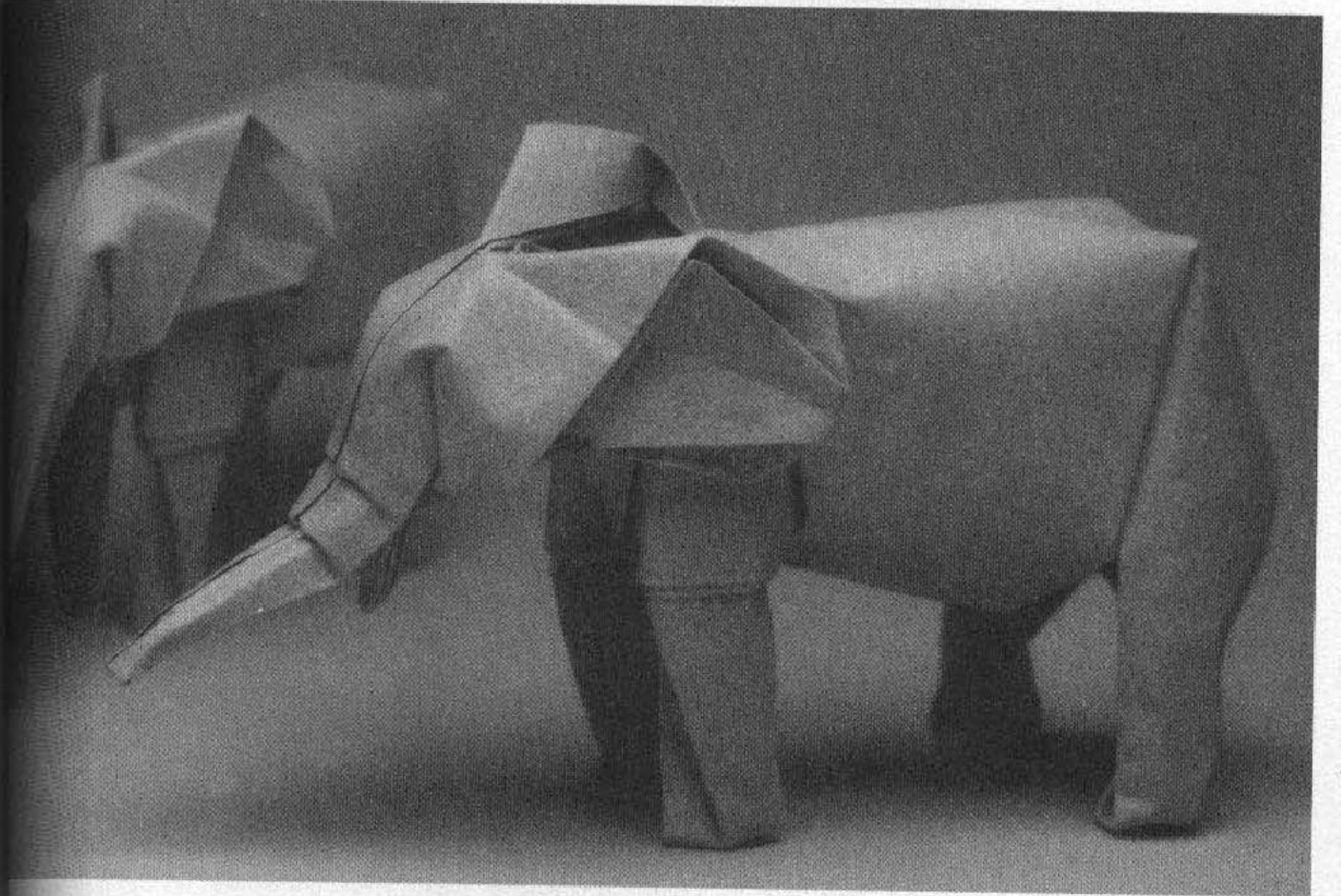
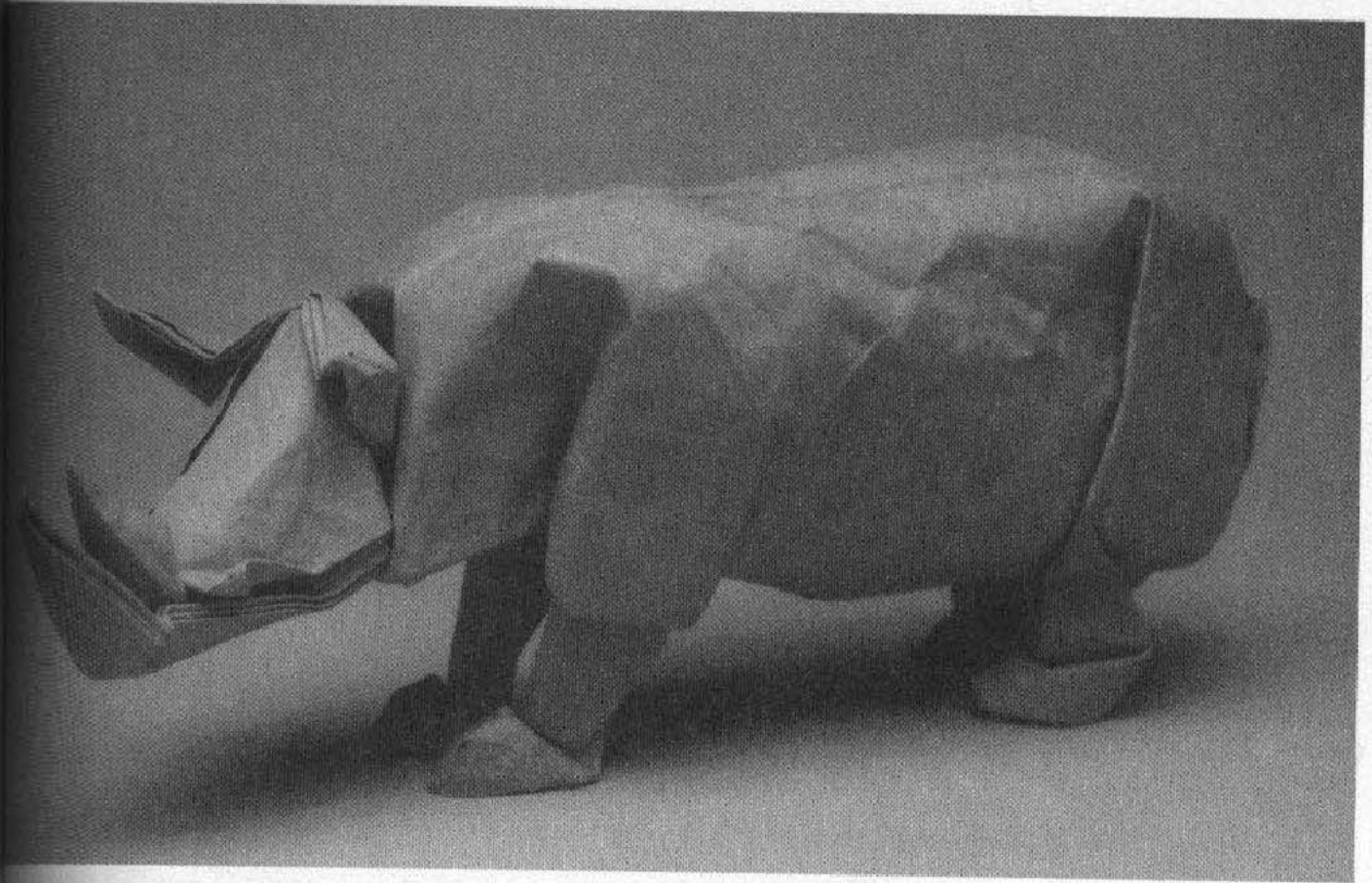

Elephant

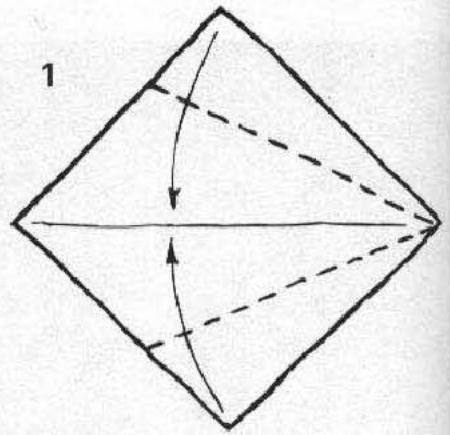

Use a large square of thickish paper
Minimum square size 12 inches (30 cm)

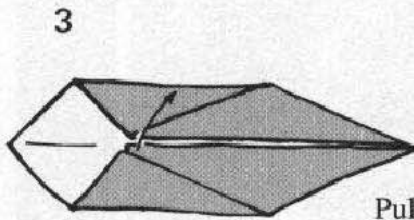
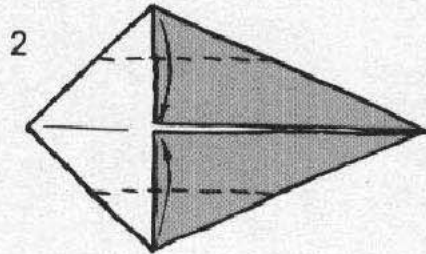

Pull out one
right-angled corner

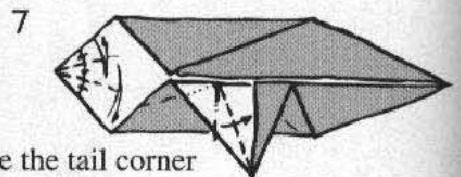
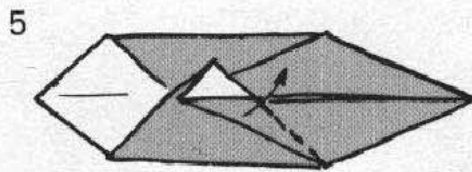
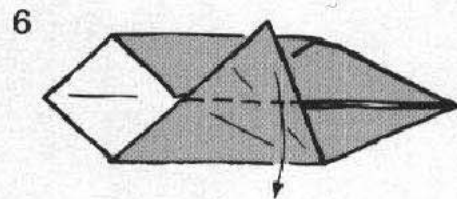
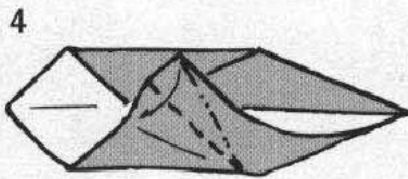

Precrease the tail corner
into 1/3rds, then repeat
the previous steps to make
the model symmetrical

I spent a lot of time developing this animal which I wanted to have a fully three-dimensional construction, having a cylindrical body with a closed stomach, as far as possible. The head and ears revolve as before, and the animal looks forward. In folding this, you will need to experiment, adjusting the illustrated folds during the formation of the body to get the best result. Try again if your first attempt fails to satisfy.

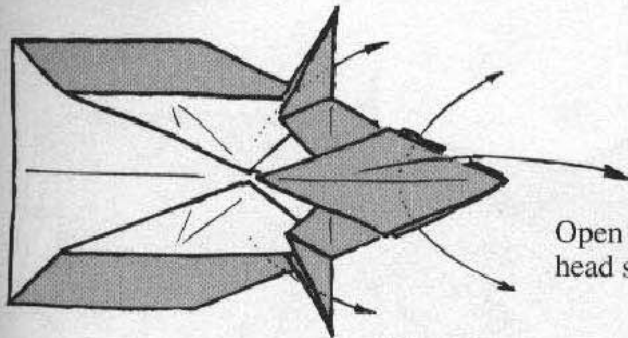

Open out the head section

13

12

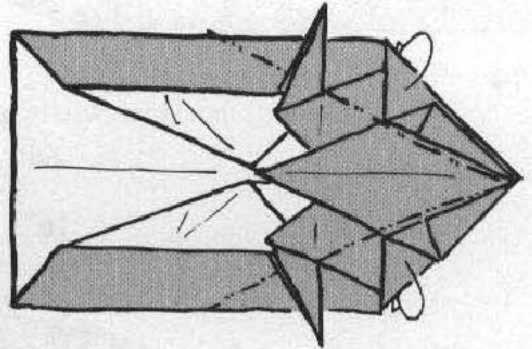

11

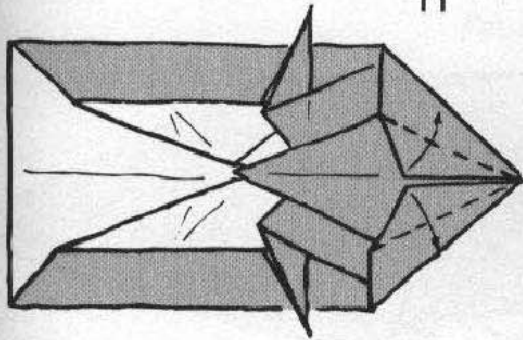

9c

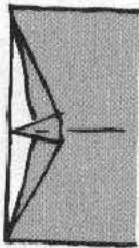

10

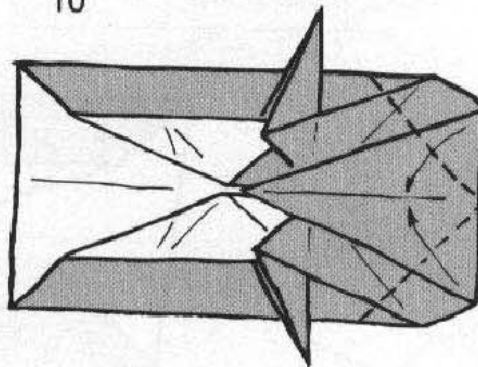

9b

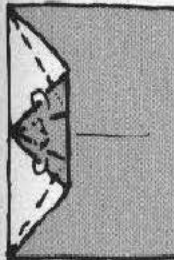

9a

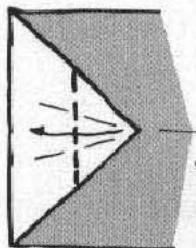

9

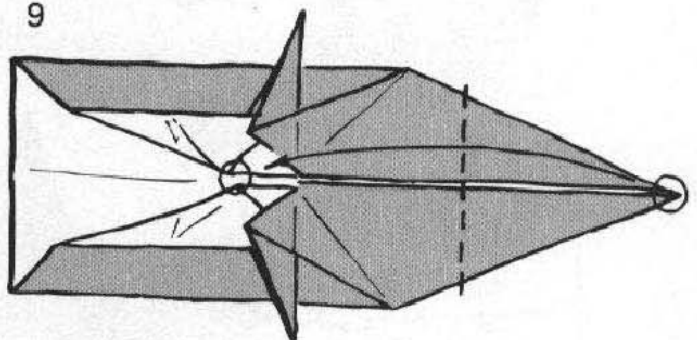

Fold along the precreased 1/3rds
The layers underneath will overlap.

8

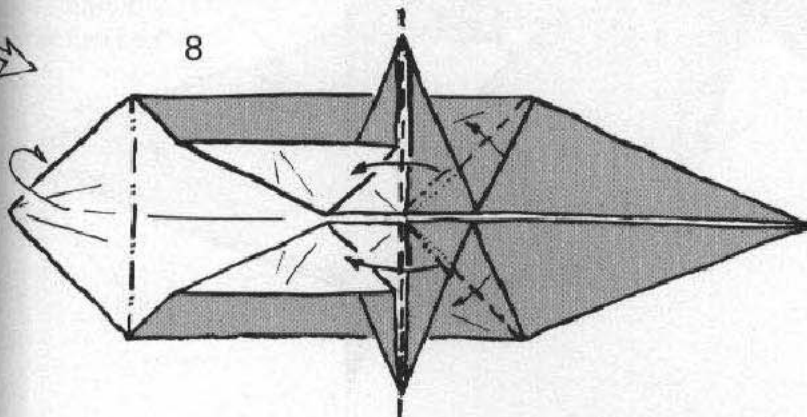

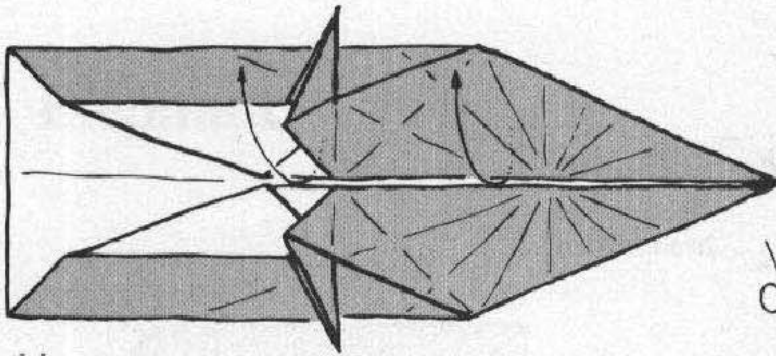

14

Lift the upper layer slightly

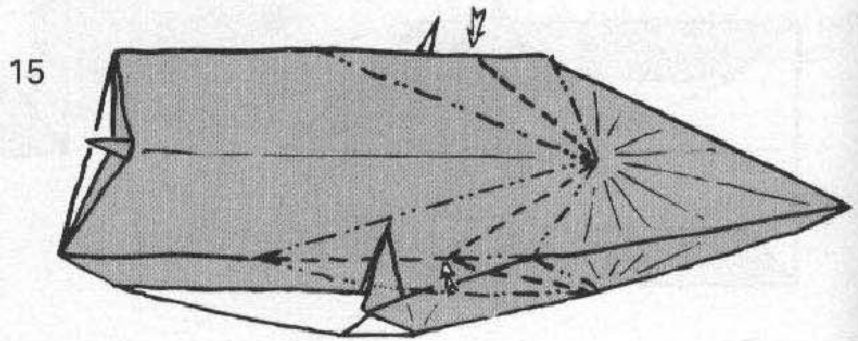

15

Sink along the precreased lines

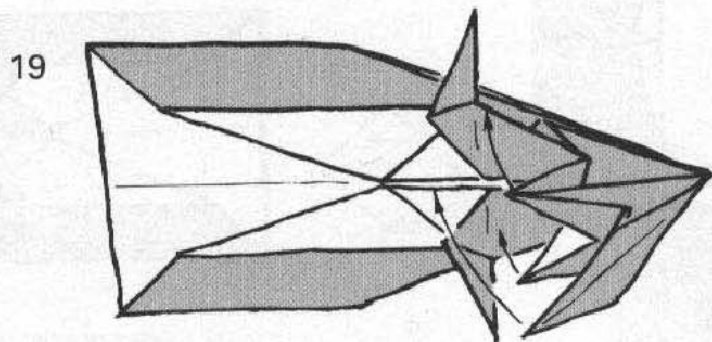

19

Collapsing almost complete

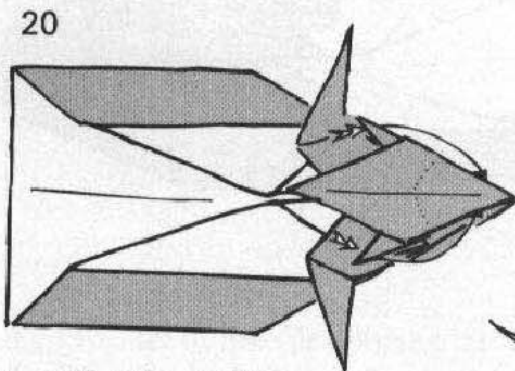

20

Reposition the ear flaps:
these lie symmetrically
between the layers

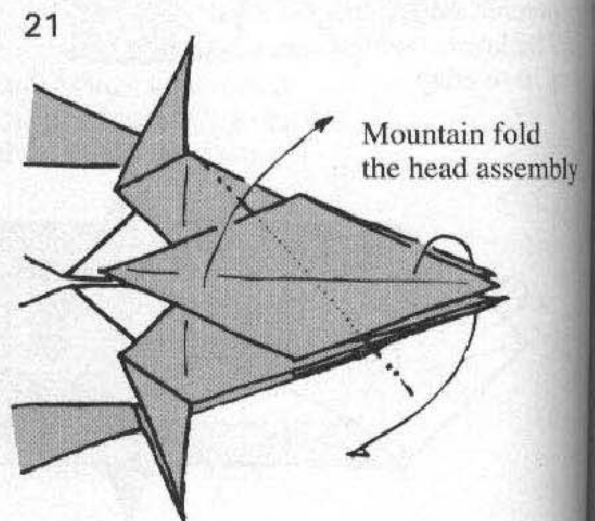

21

Mountain fold
the head assembly

16

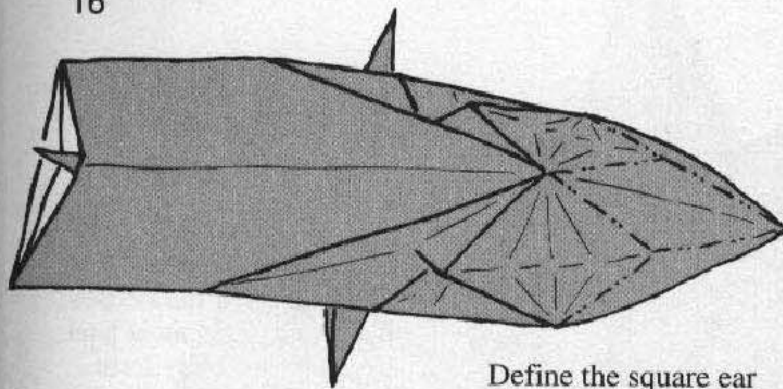

Define the square ear flaps with mountain folds

17

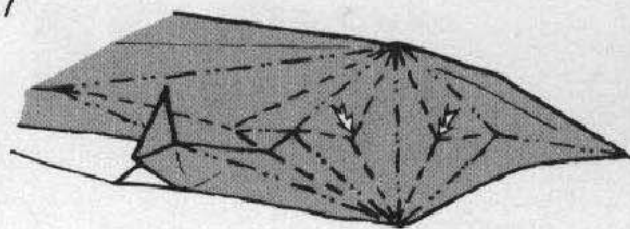

Collapse along the precreased lines

18

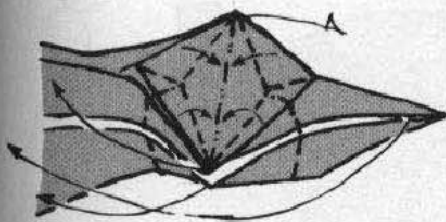

The square ear flaps are collapsed using fish base-like creases

23

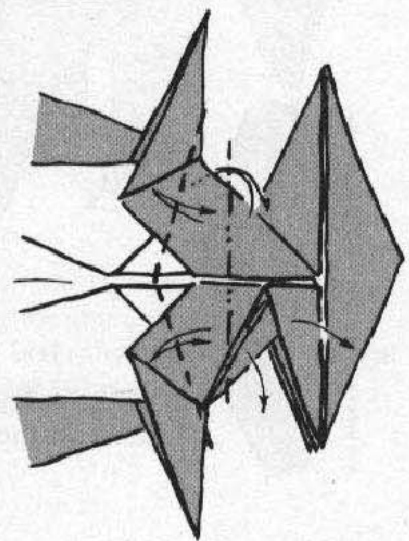

Precrease the crimp which will form the shoulder line, then unfold the creases made in 22

22

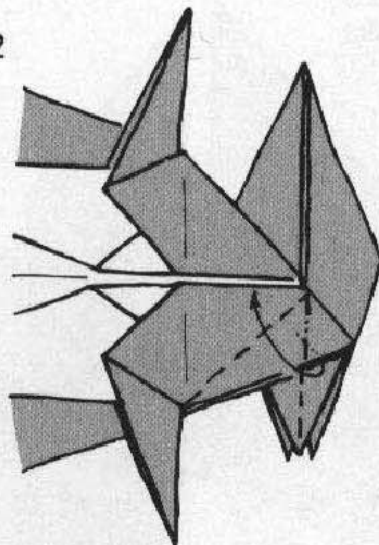

Swivel-fold the other side of the neck

24

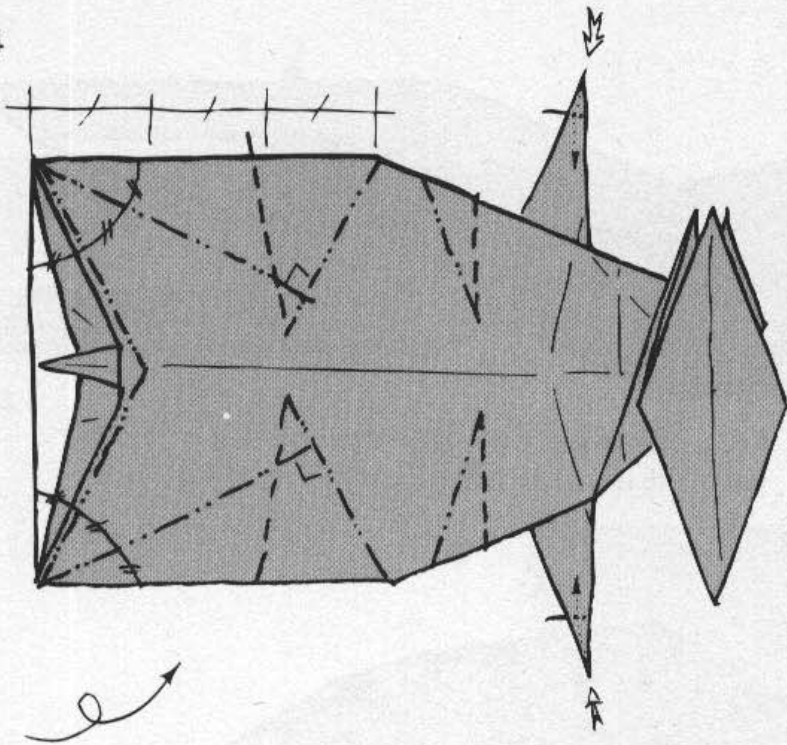

Precrease as shown:
the position of the creases
may need adjustment later
to ensure the body forms
a solid 3D shape

25

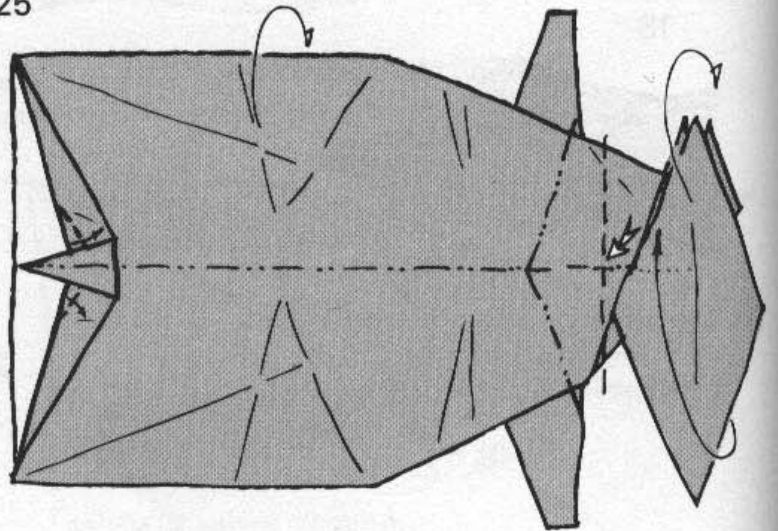

26

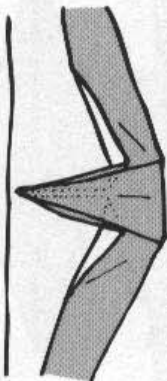

Narrow the layers
underneath the tail

Reform the shoulder crimp
precreated in 23

27

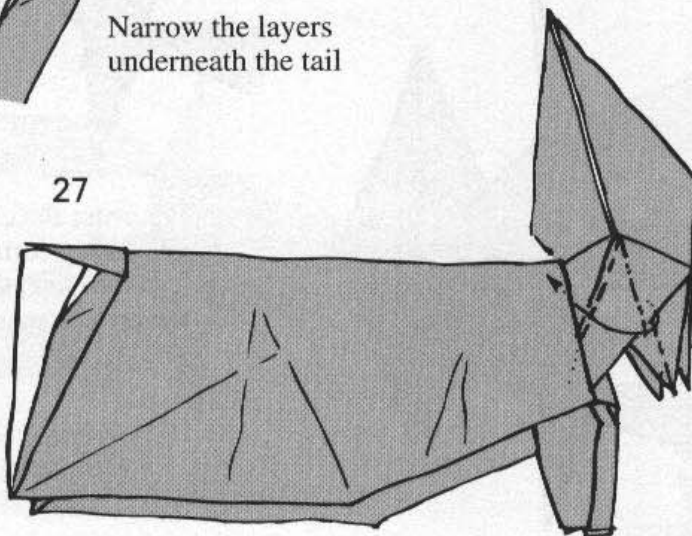

These creases lock the
neck and head assembly
to the body

28

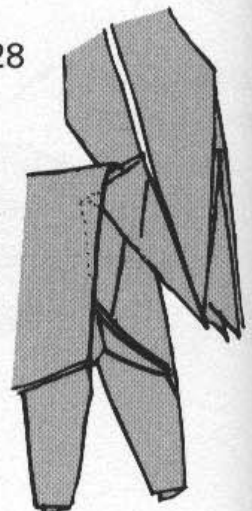

31

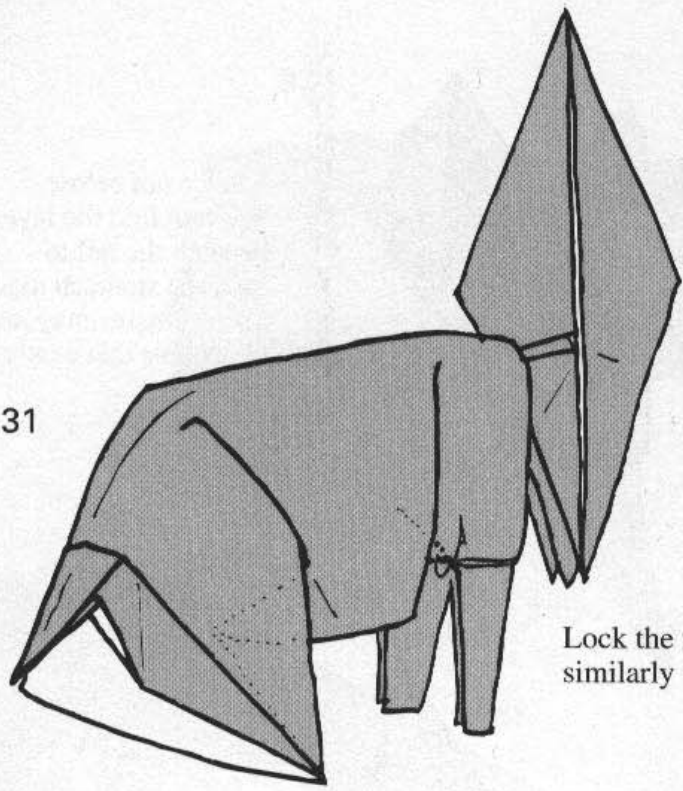

Lock the front legs similarly

30

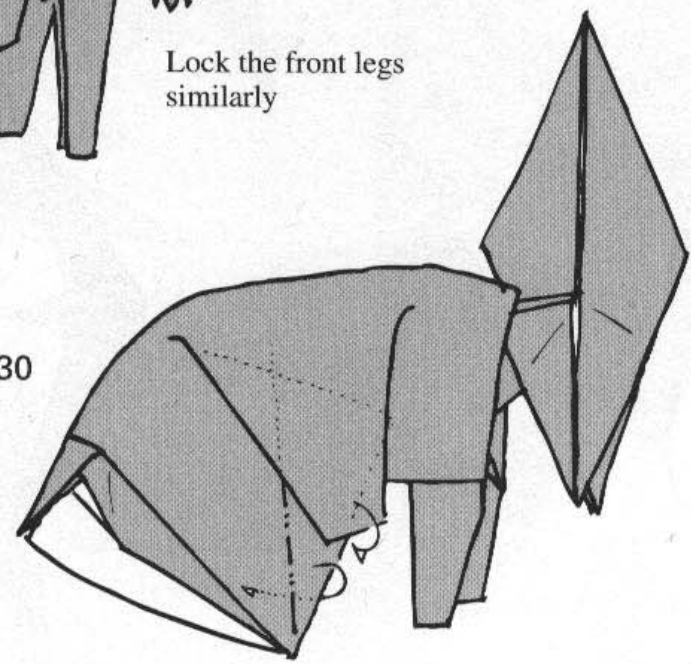

Lock the rear legs: the layers forming the stomach do not lie flat and the body should now form an oval tube shape in cross-section

29

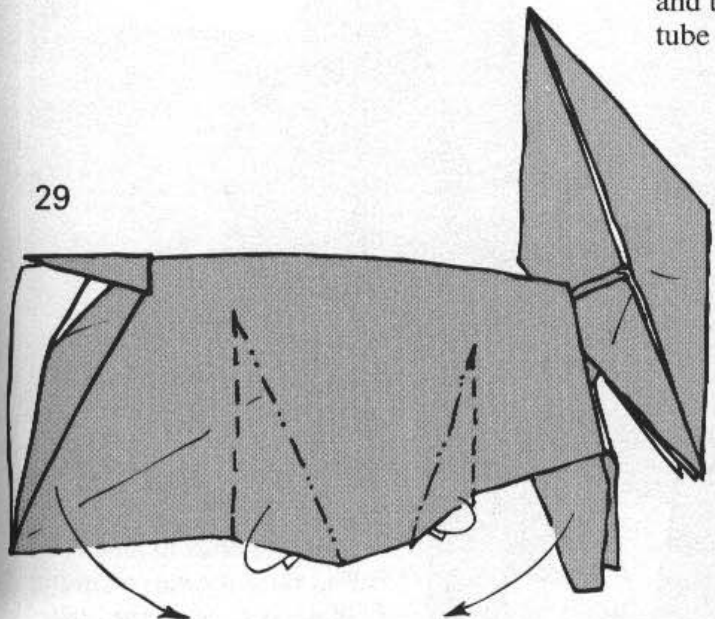

Start to form the body and leg crimps

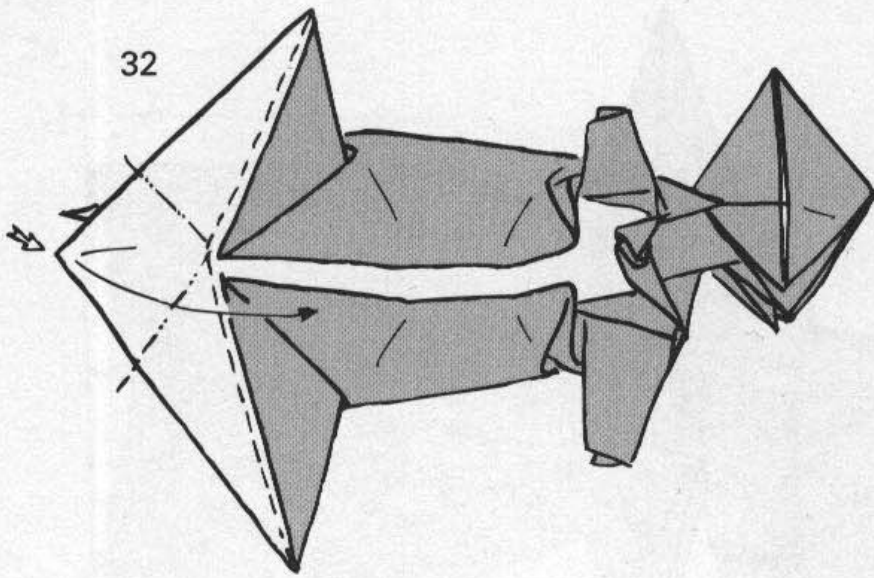

View from below.
Reverse fold the layer
beneath the tail to
hold the stomach together.
Some creases may need adjusting
to achieve this neatly.



Formation of the rear legs

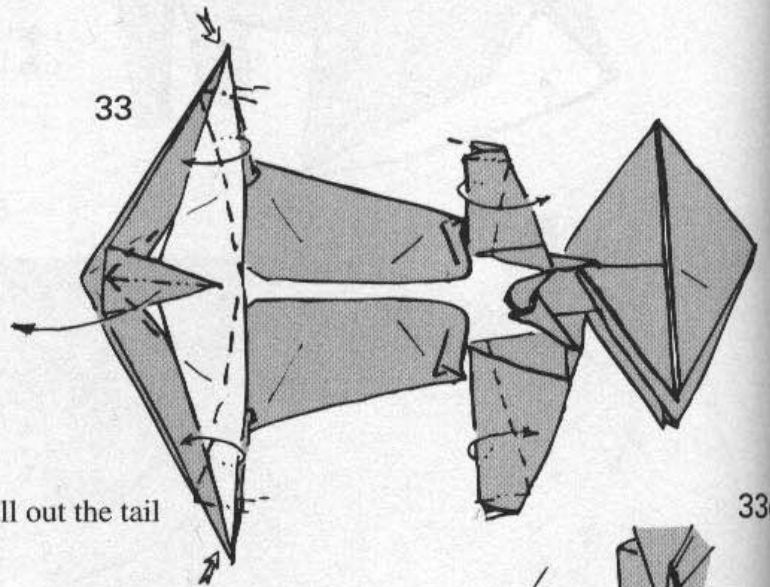
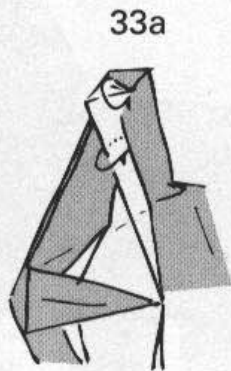

Pull out the tail

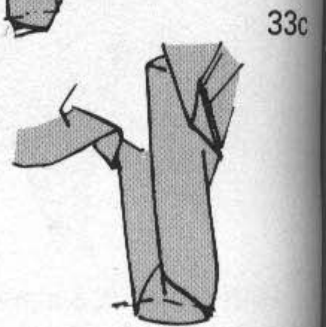

Formation of the front leg

Push in the top of the body gently

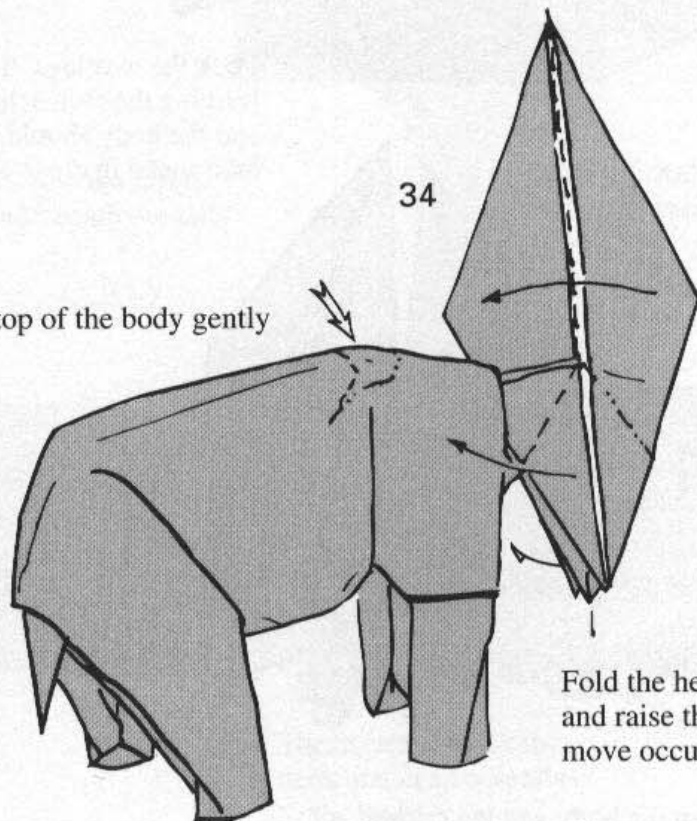

Fold the head in half,
and raise the ear: a similar
move occurs on the other side

37

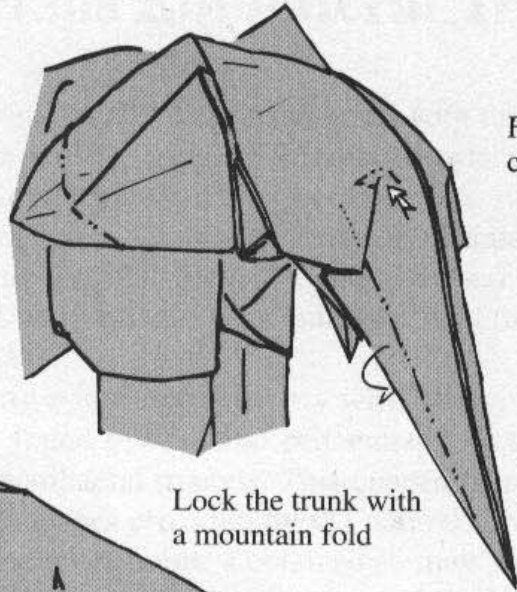

Form the eye carefully

36

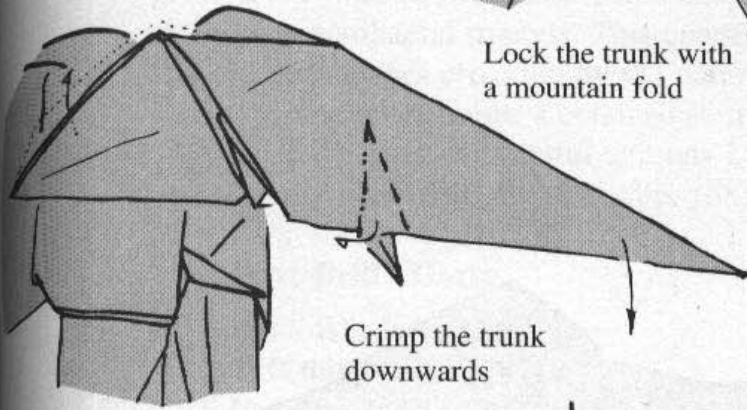

Lock the trunk with a mountain fold

Crimp the trunk downwards

Pull out the upper edge of the ear to make a rounder shape

38

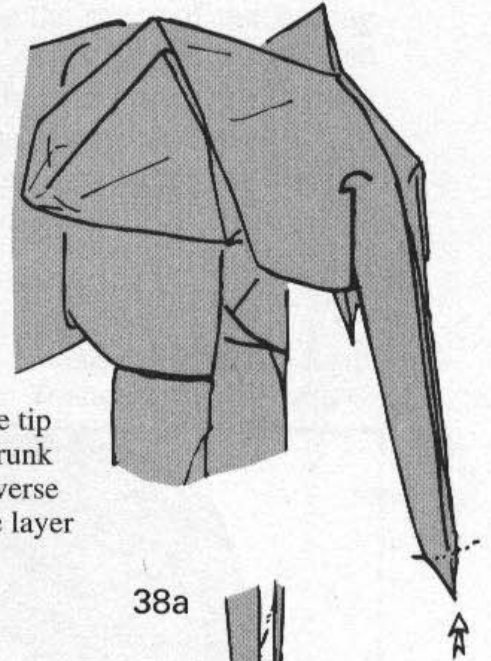

Sink the tip of the trunk then reverse fold the layer within

38a



35

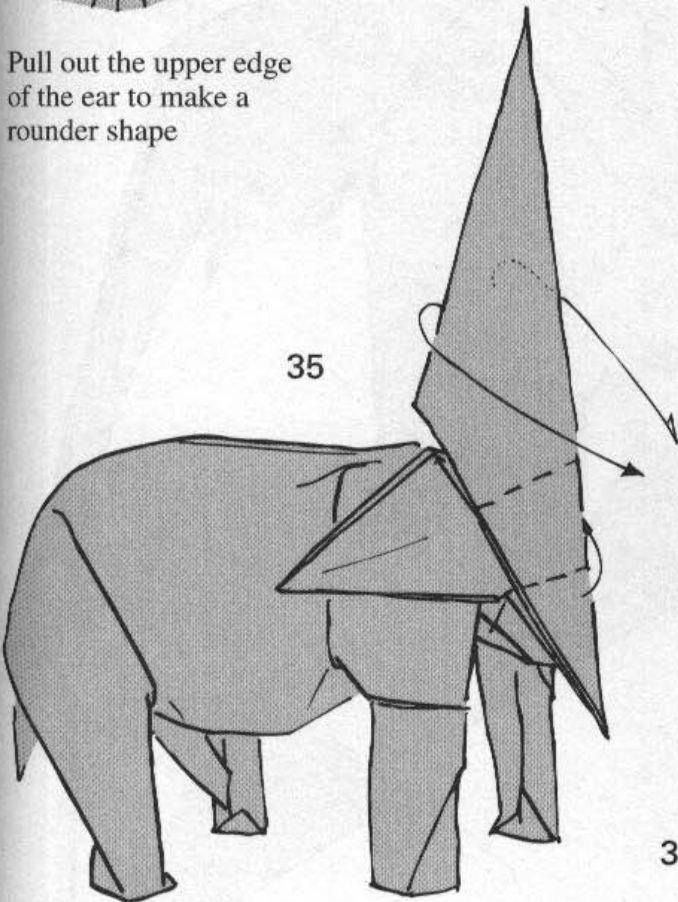

35a

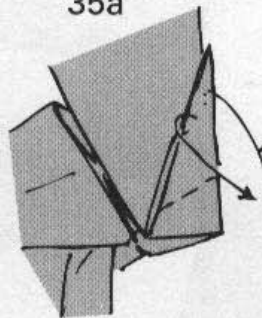

35c

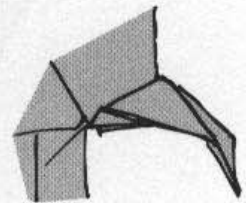

35b

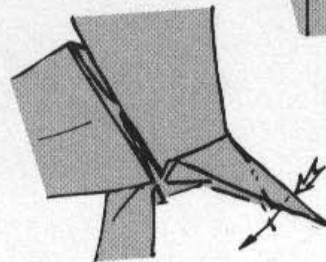

Formation of the mouth: Reverse fold the head and trunk after the mouth has been completed

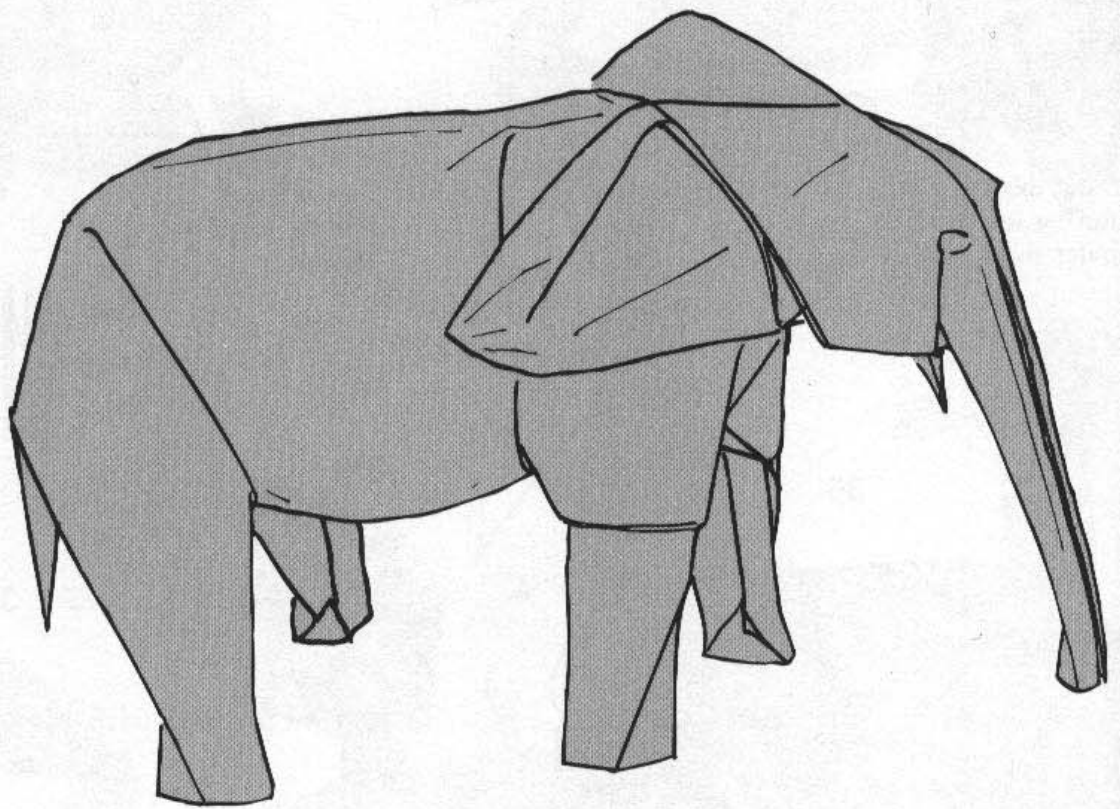

Square Versus Equilateral Triangle

As I have mentioned, I was preoccupied with the use of the blintz bird base when I first began folding animals. Successful examples of animals folded from this starting point included in this book are the fox and the reindeer. But I soon exhausted my ideas, finding the many disadvantages of this approach. Apart from a growing reluctance to use the over-familiar shapes provided by the base, I found that I was limited by its bulkiness, and the short limbs which my animals seemed to have.

Attempting some experiments with tri-section of the standard bird base geometry, I found that I could economize by changing the shape of the starting sheet to an equilateral triangle. This opened many new doors for me, and I found that the new shapes provided by the natural folds in the paper were much more attractive, and furthermore, I obtained animals with much slenderer limbs.

Three of the most successful animals I folded follow: I'm pleased to include here a poem inspired by the Horse. (p. 168).

Dave Brill's Horse

But this is just a horse,
This thing of paper plain
For these folds form
The sinews of a stallion,
A wild free living beast.
Thus can life shine through
The constraints of our art.

John Smith

Method of cutting an Equilateral Triangle from a Rectangle.

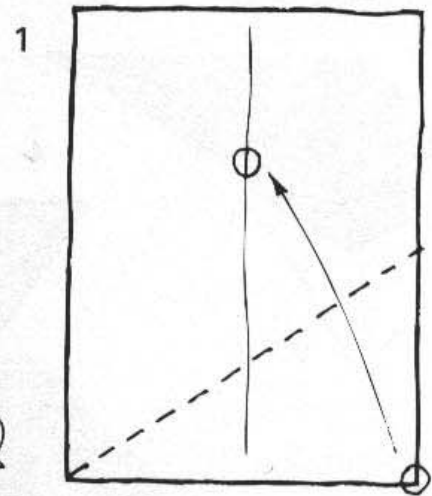

2

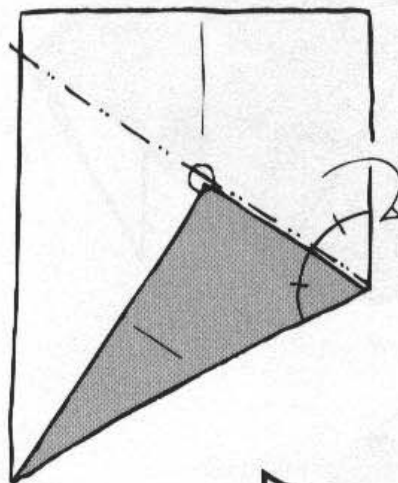

3

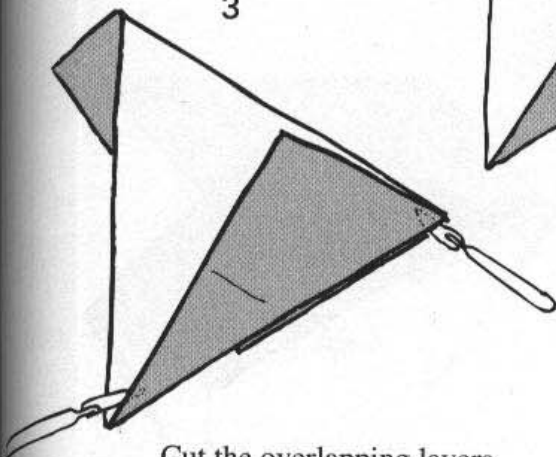

Cut the overlapping layers
to leave the triangle

4

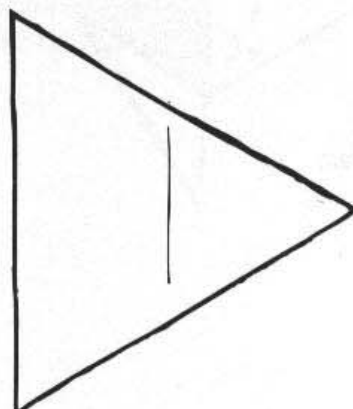

Lioness

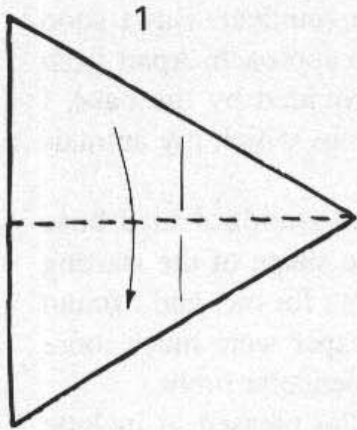
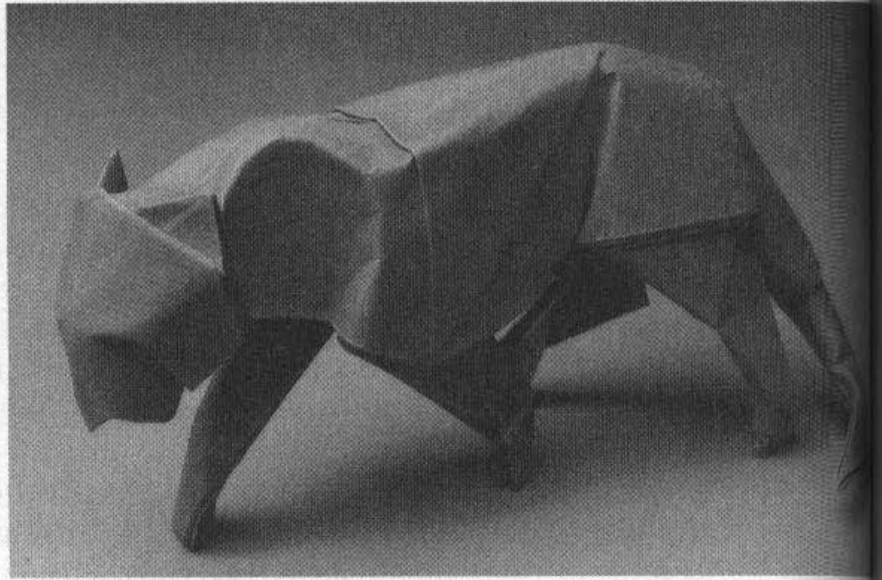

Start with a large equilateral triangle cut from an A2 sheet of thickish paper

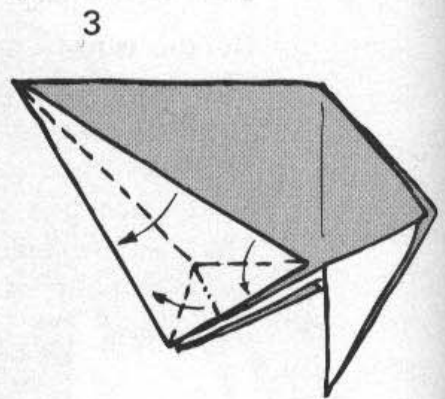
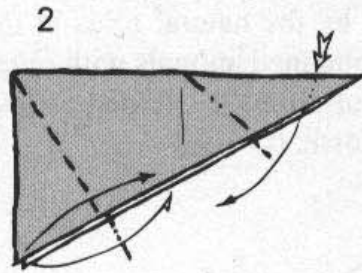

Form rabbit ear folds on the layers at the front and back

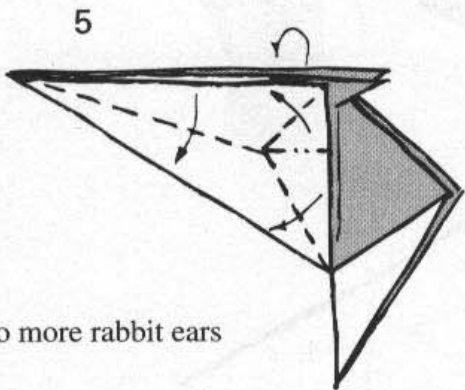
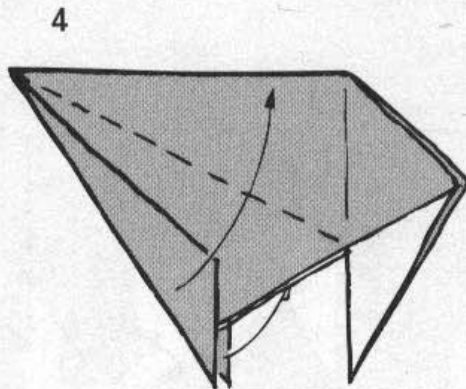

Two more rabbit ears

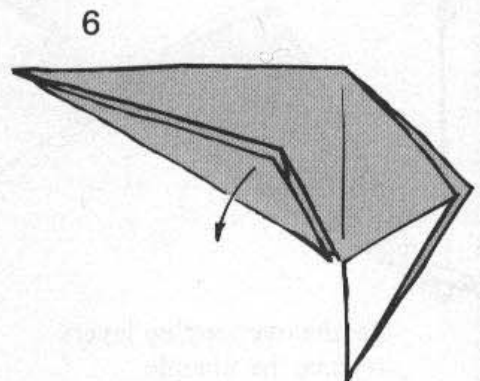

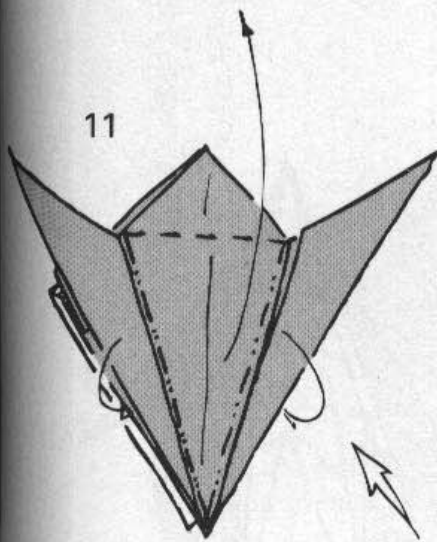

11

Petal fold, allowing the points at left and right to swing down

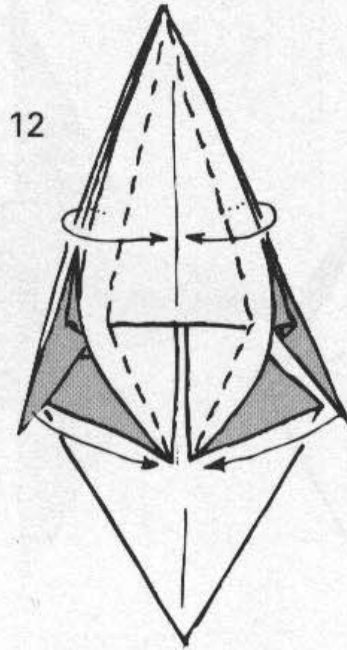

12

Petal fold complete. Open up

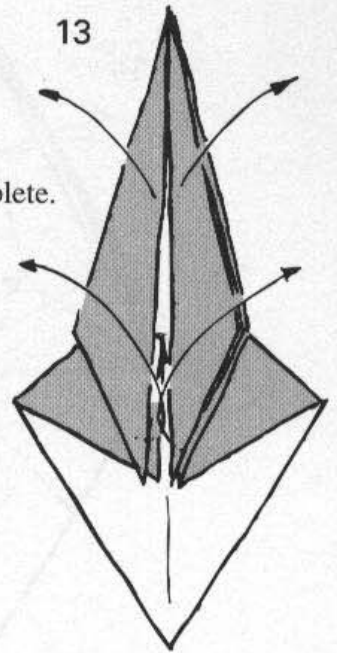

13

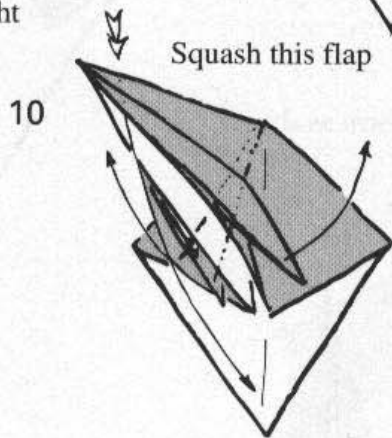

10

Squash this flap

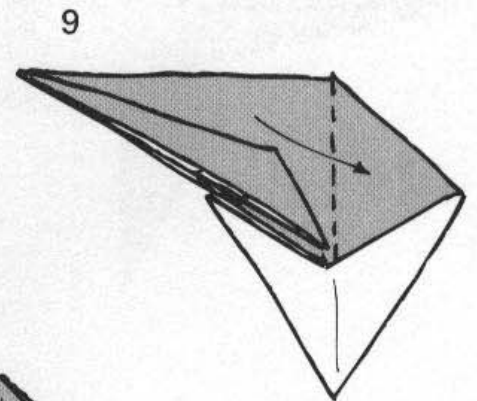

9

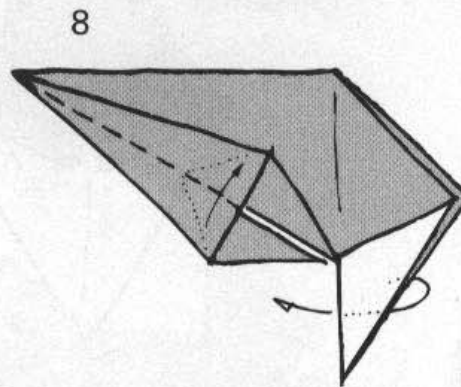

8

Repeat these steps on the other side

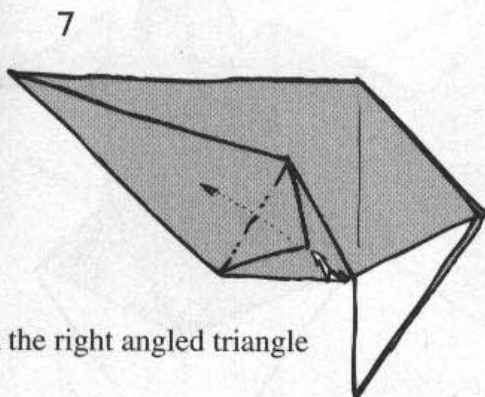

7

Sink the right angled triangle

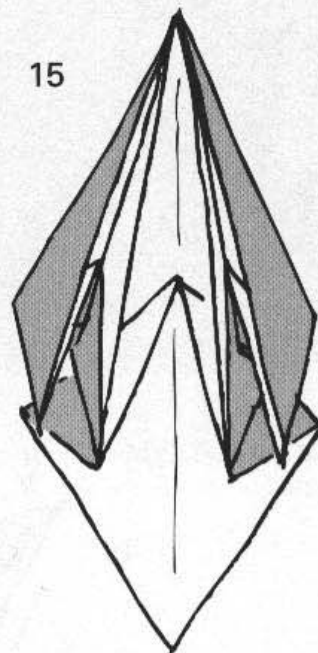
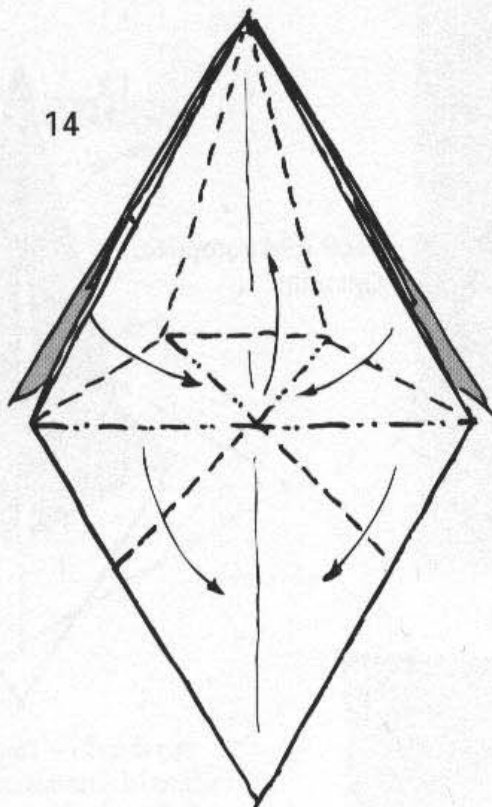

Reform as shown

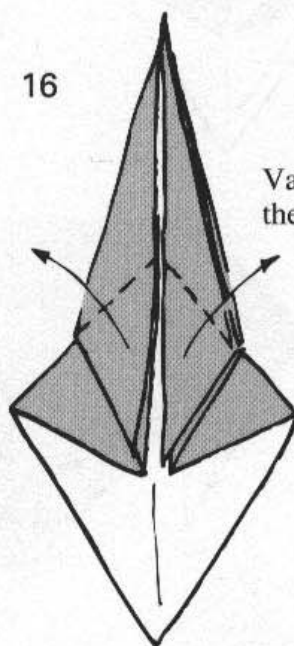

Valley fold
the rear leg flaps

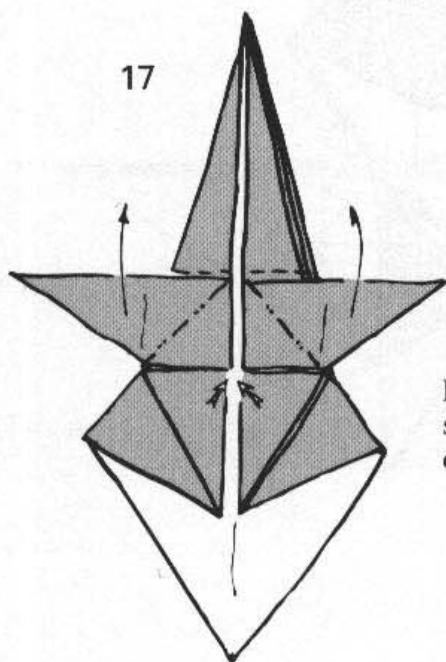

Reposition the rear legs,
squashing 2 right-angled
corners

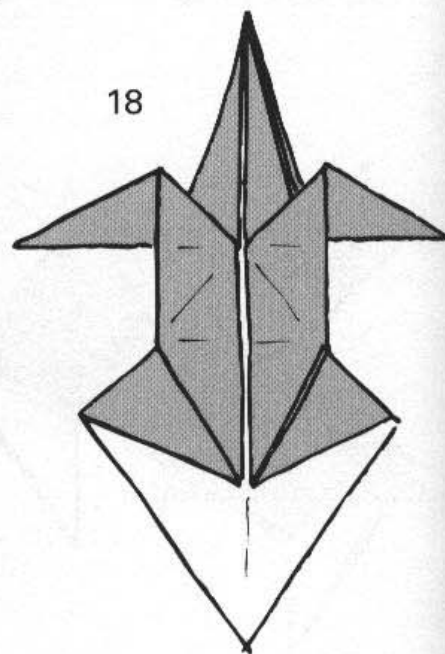

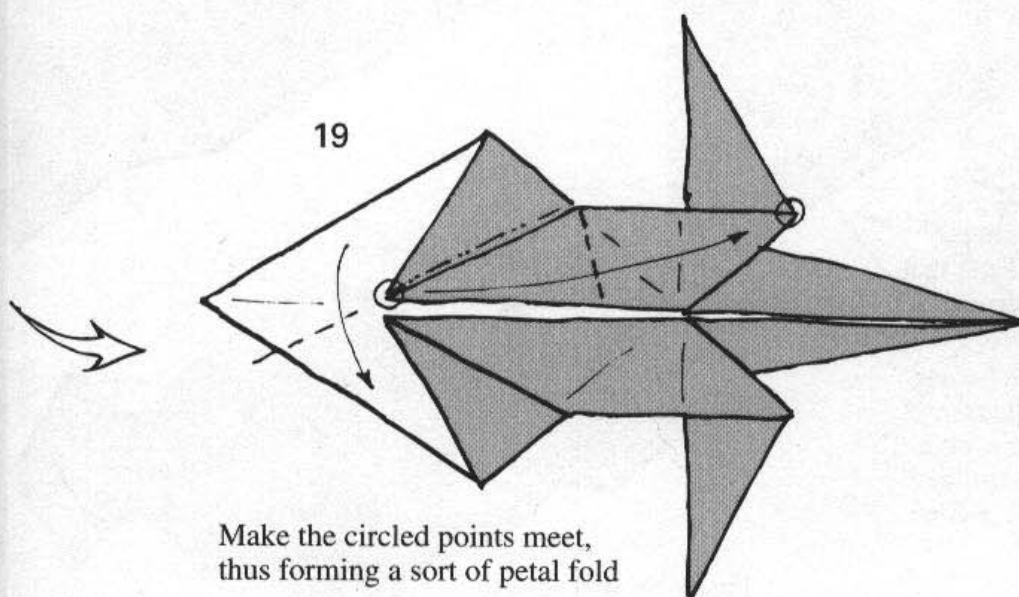
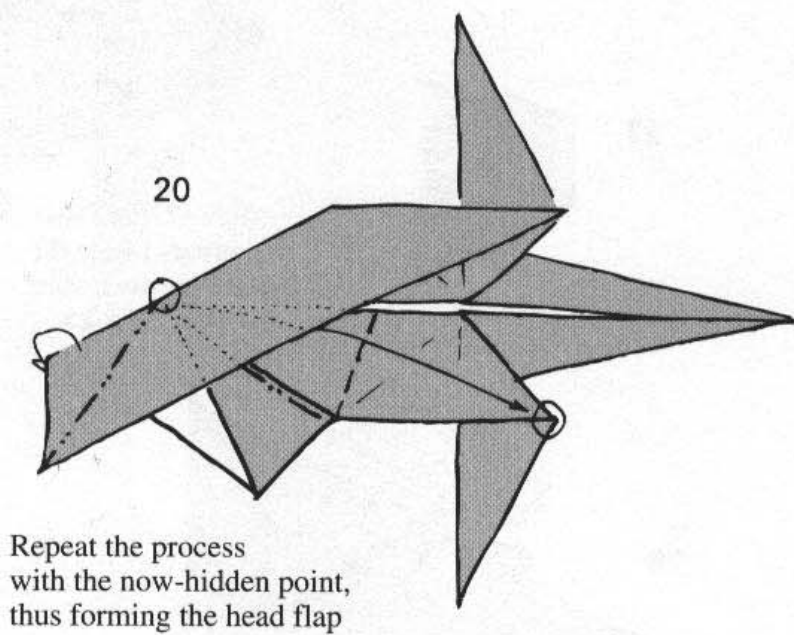
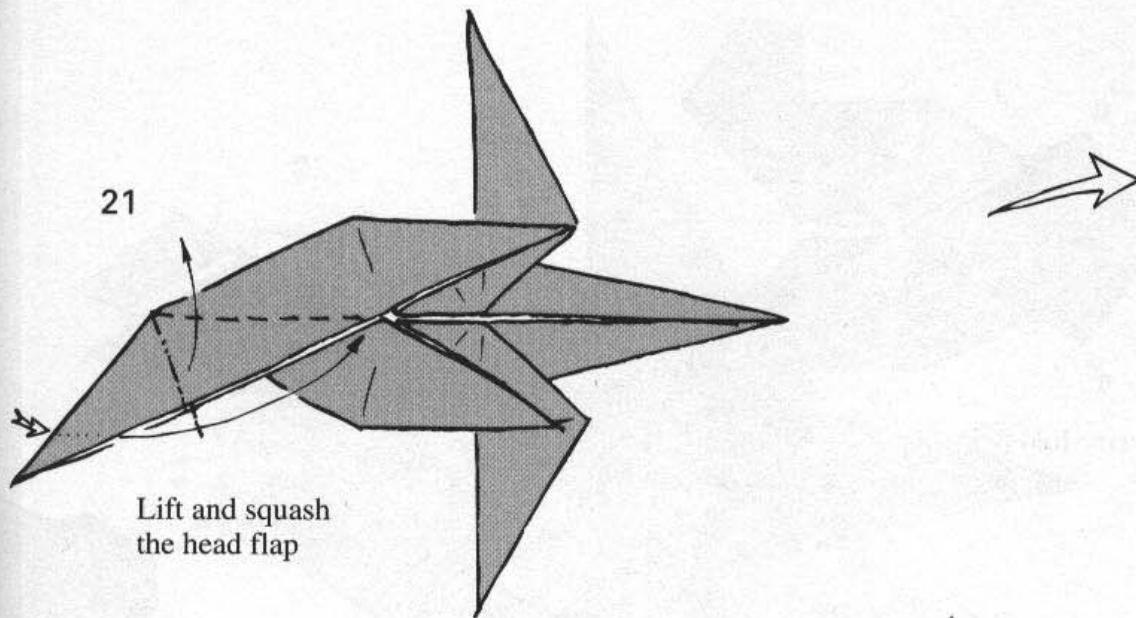

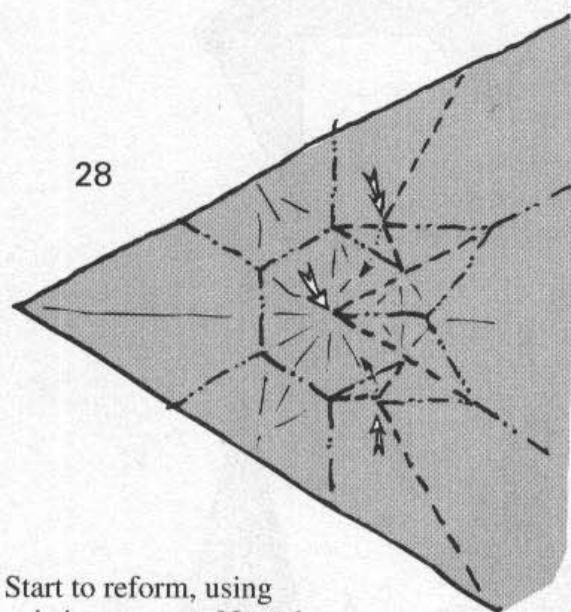
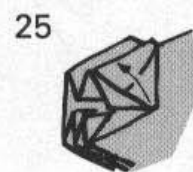
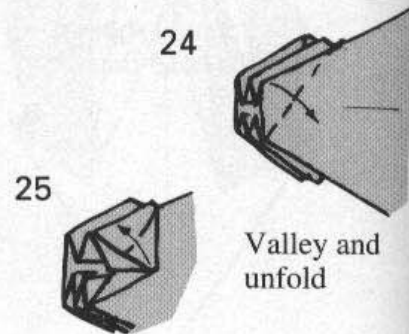
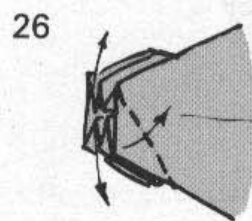
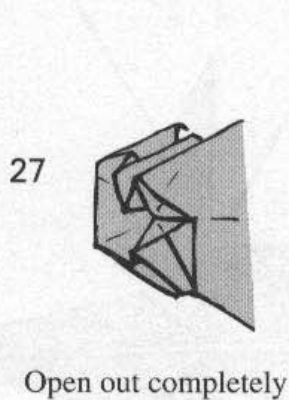
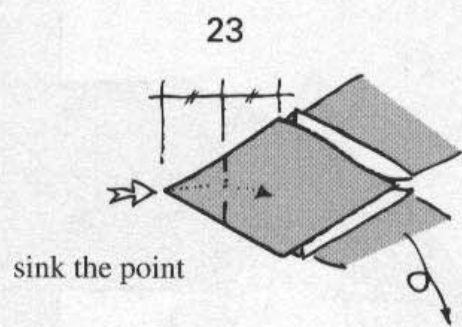
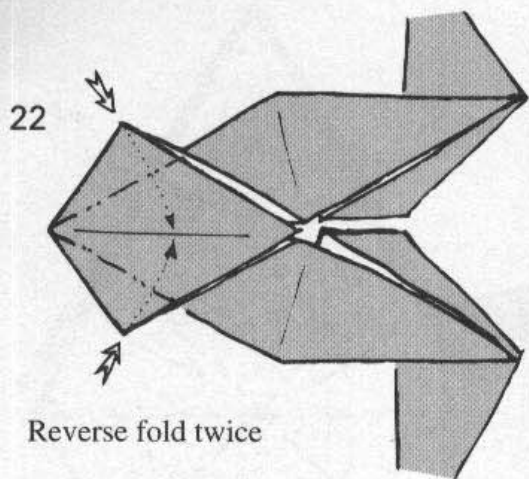

Start to reform, using existing creases. Note that the two smallest arrowed triangles are revolved underneath.

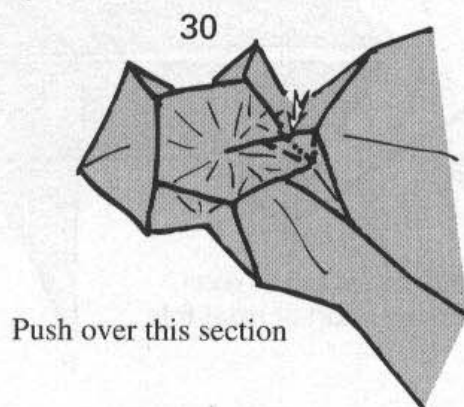
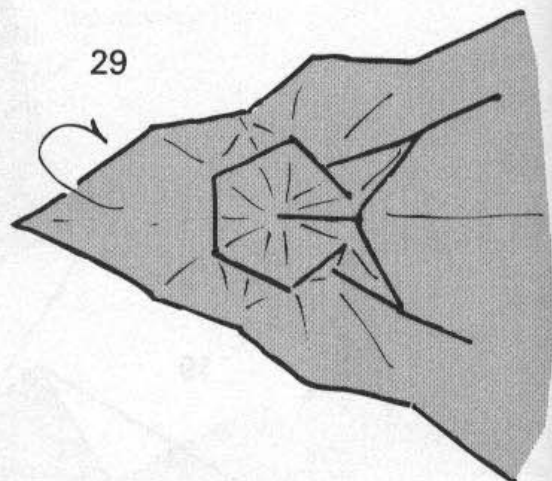

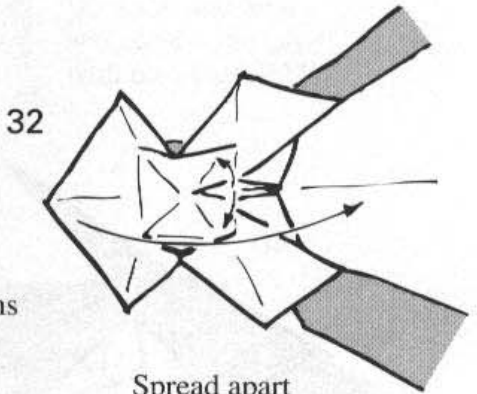
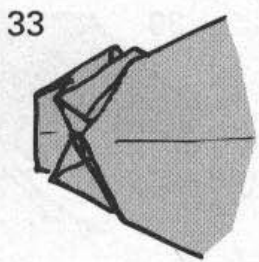
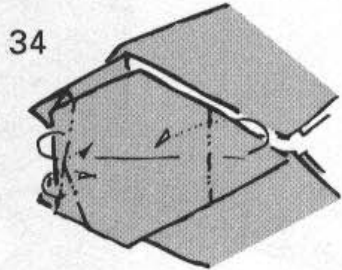
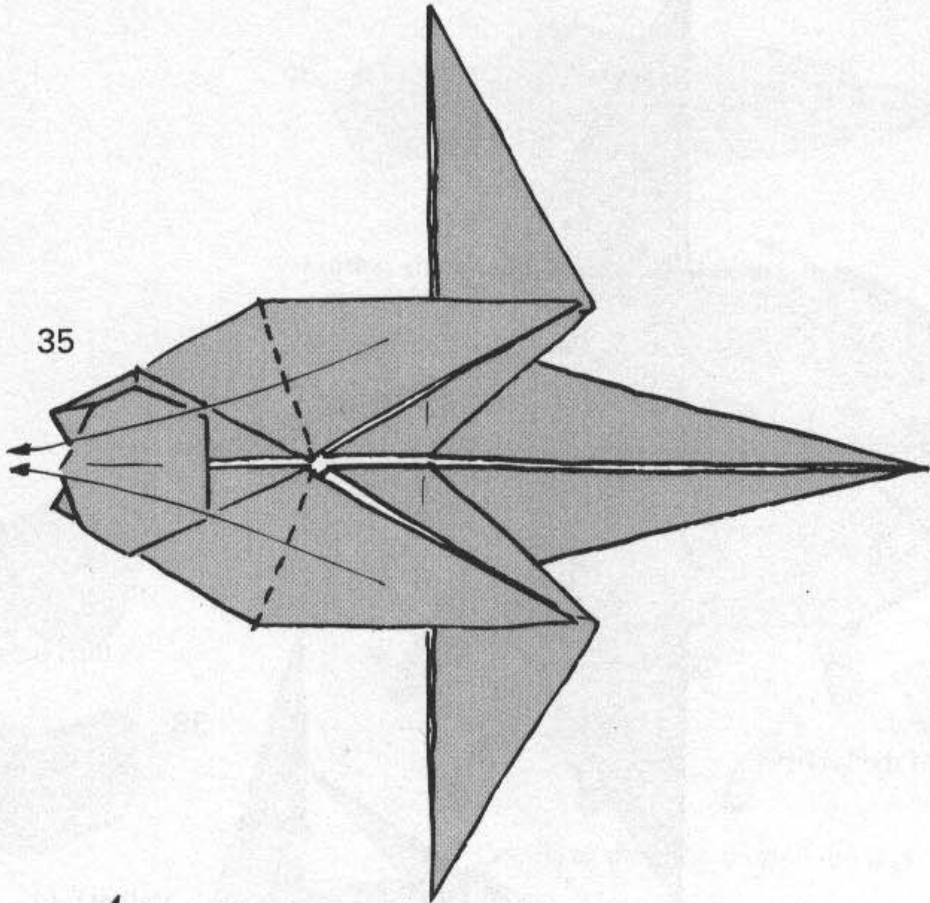

Collapse the entire head section following these diagrams

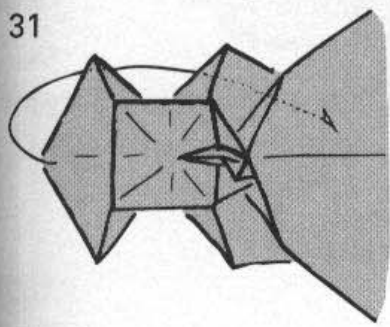

Spread apart the small flaps in the centre to allow the head section to flatten

36

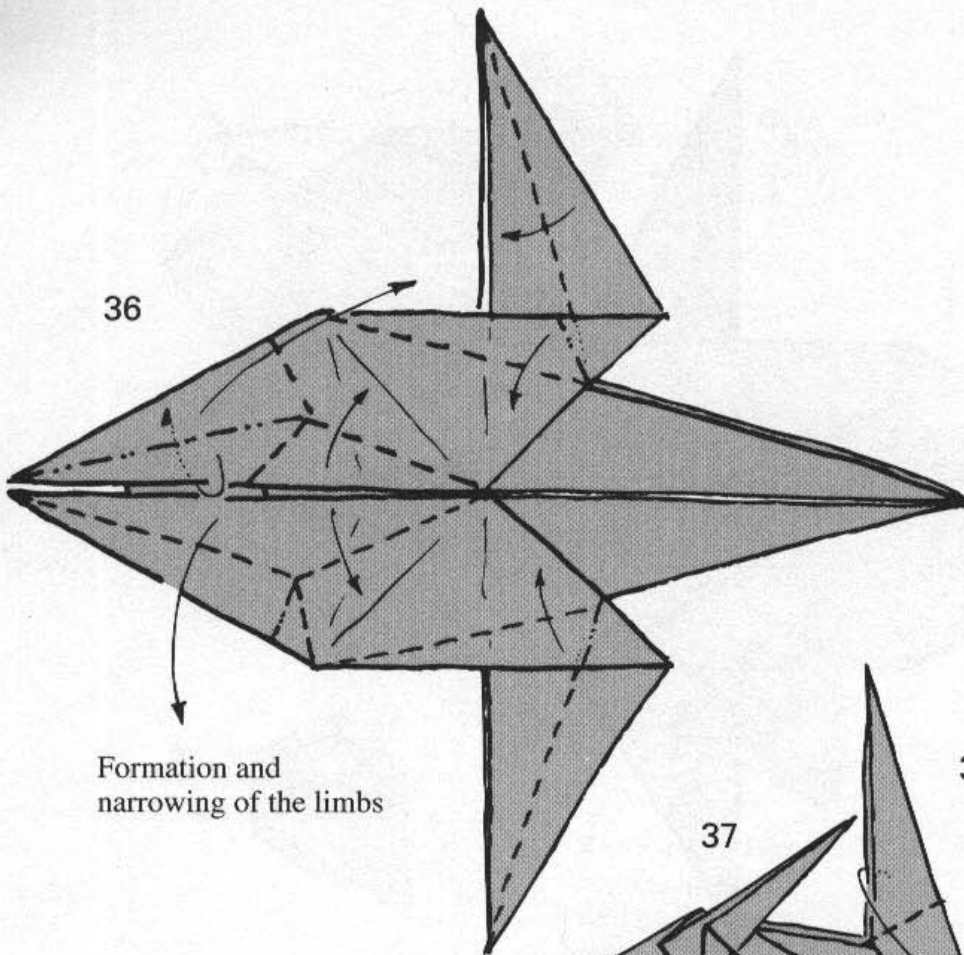

Formation and narrowing of the limbs

then outside reverse fold

38

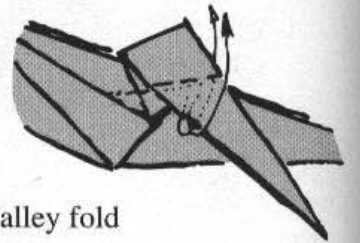

Valley fold

37

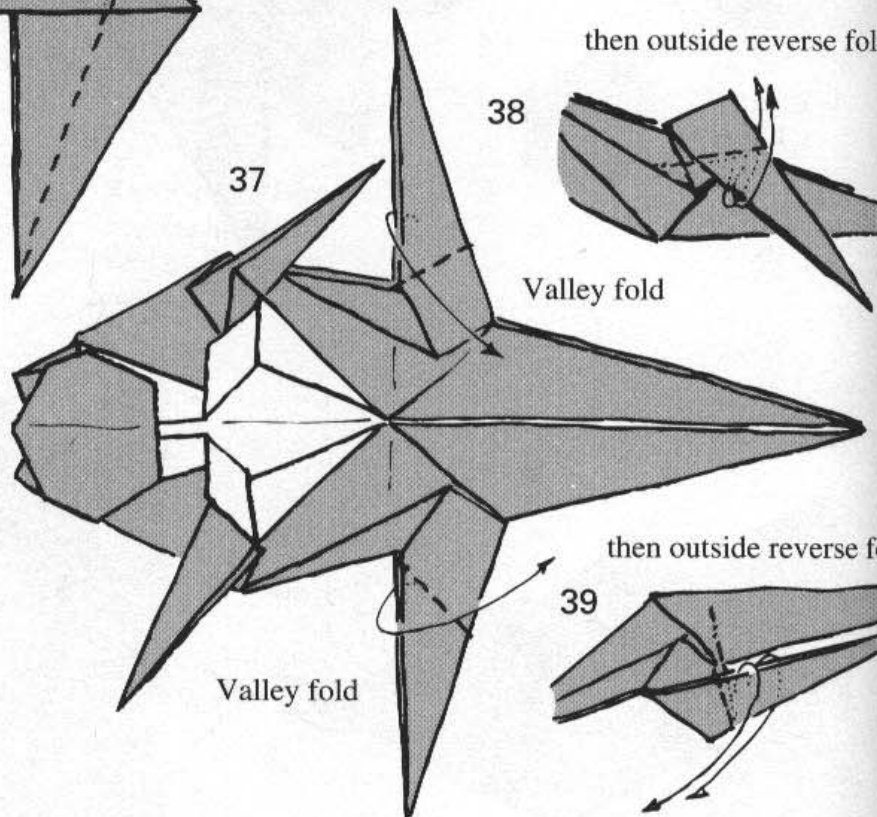

Valley fold

then outside reverse fold

39

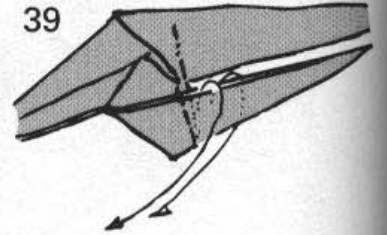

40

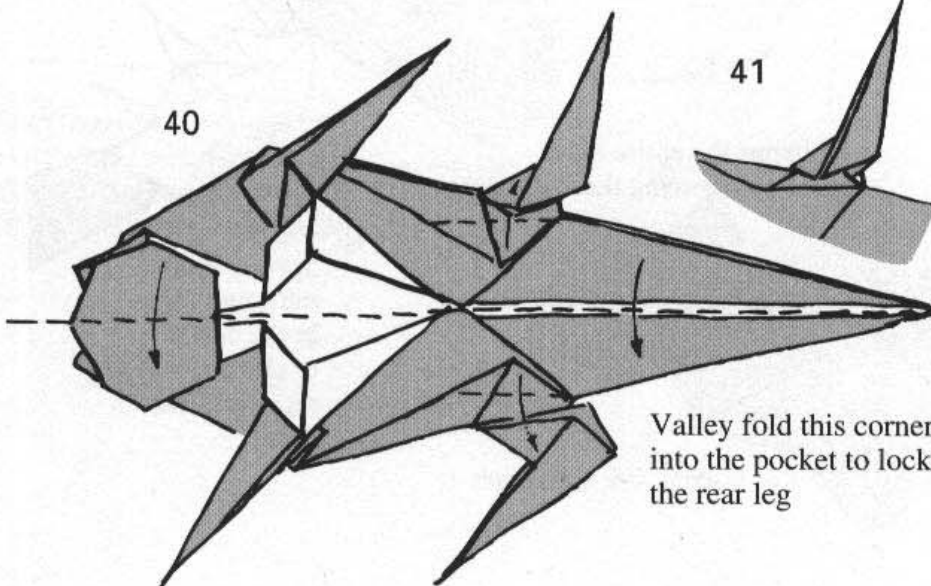

Valley fold this corner into the pocket to lock the rear leg

41

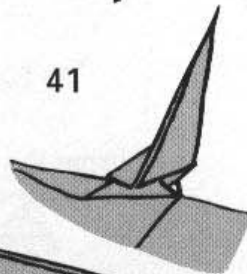

Fold the entire body in half

48

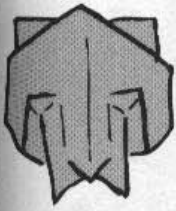

47

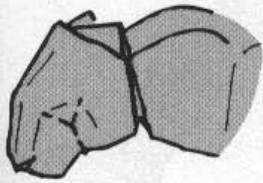

46

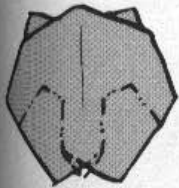

Formation of the eyes, and nose, and shaping of the head

45

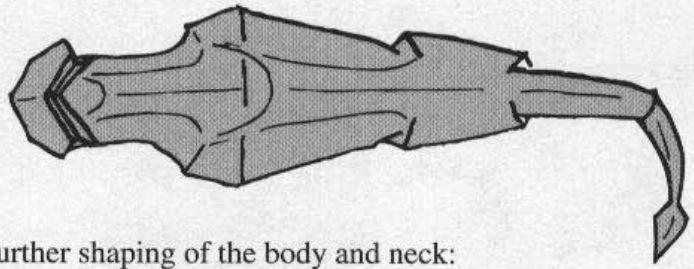

Further shaping of the body and neck: squeeze in these curved mountain folds

44

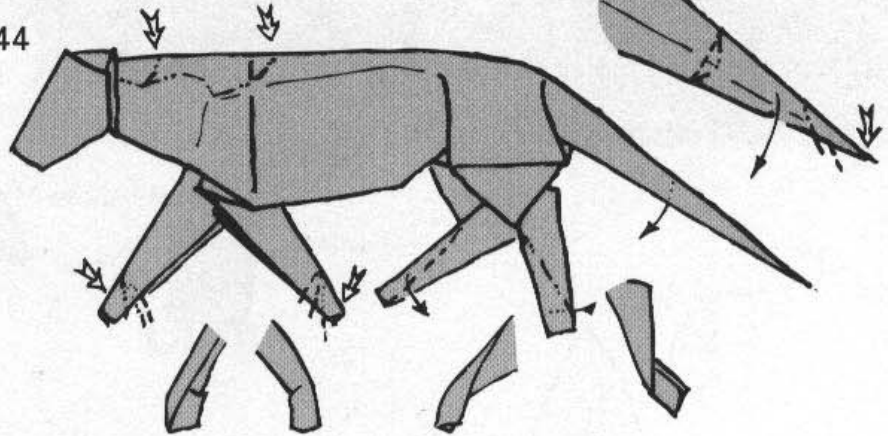

Details of the formation of the legs

43

Begin shaping the body by squeezing in these mountain folds

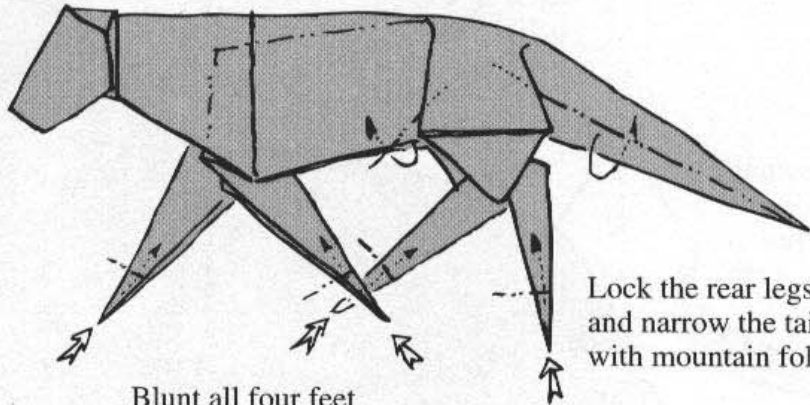

Blunt all four feet

Lock the rear legs and narrow the tail with mountain folds

42

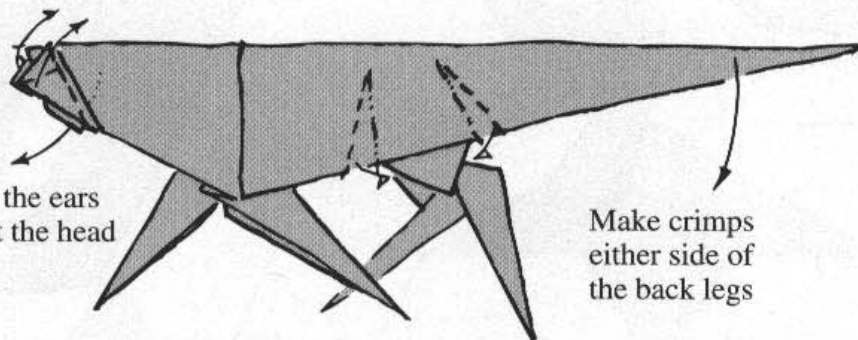

Valley fold the ears and pull out the head

Make crimps either side of the back legs

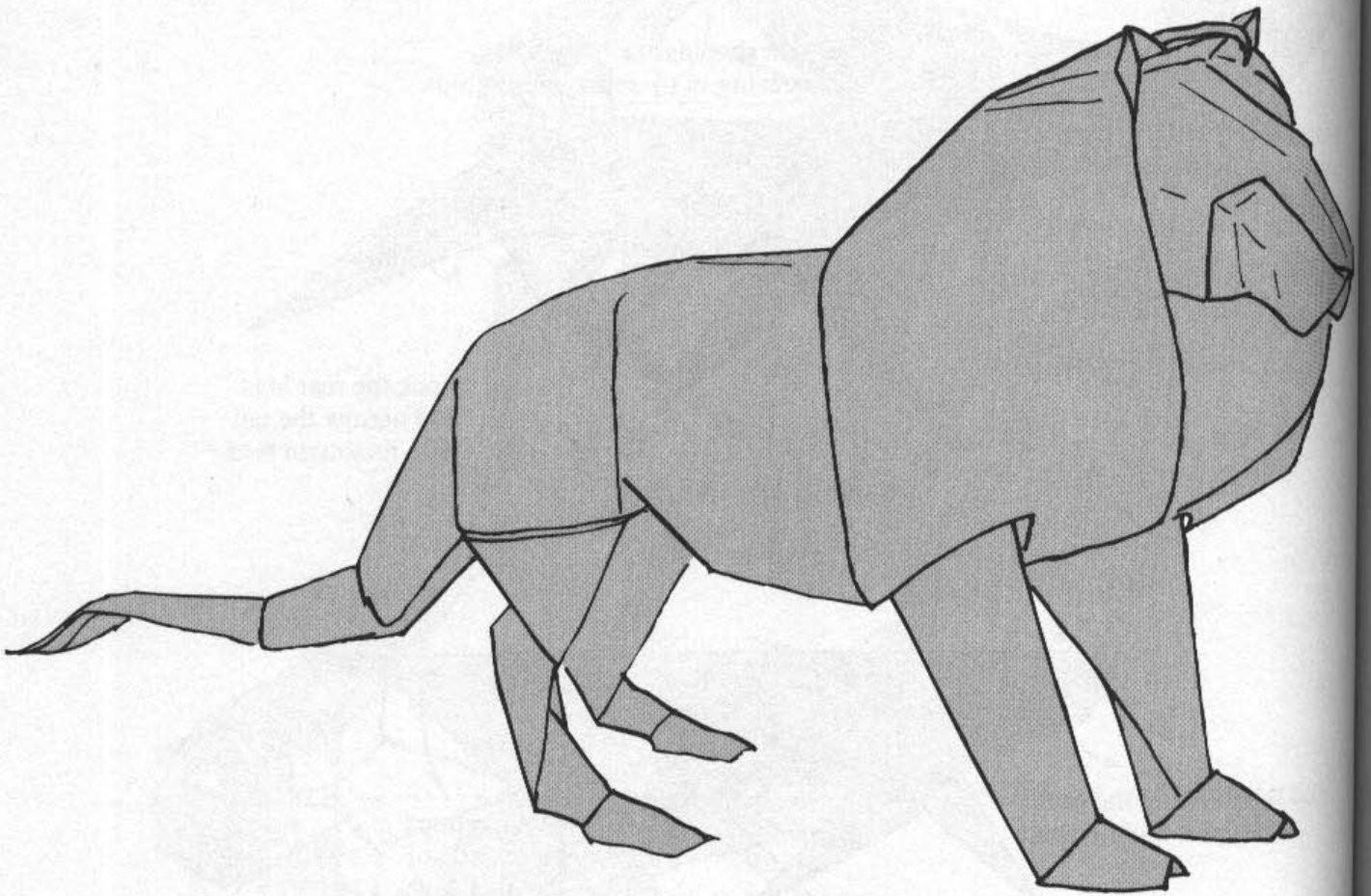
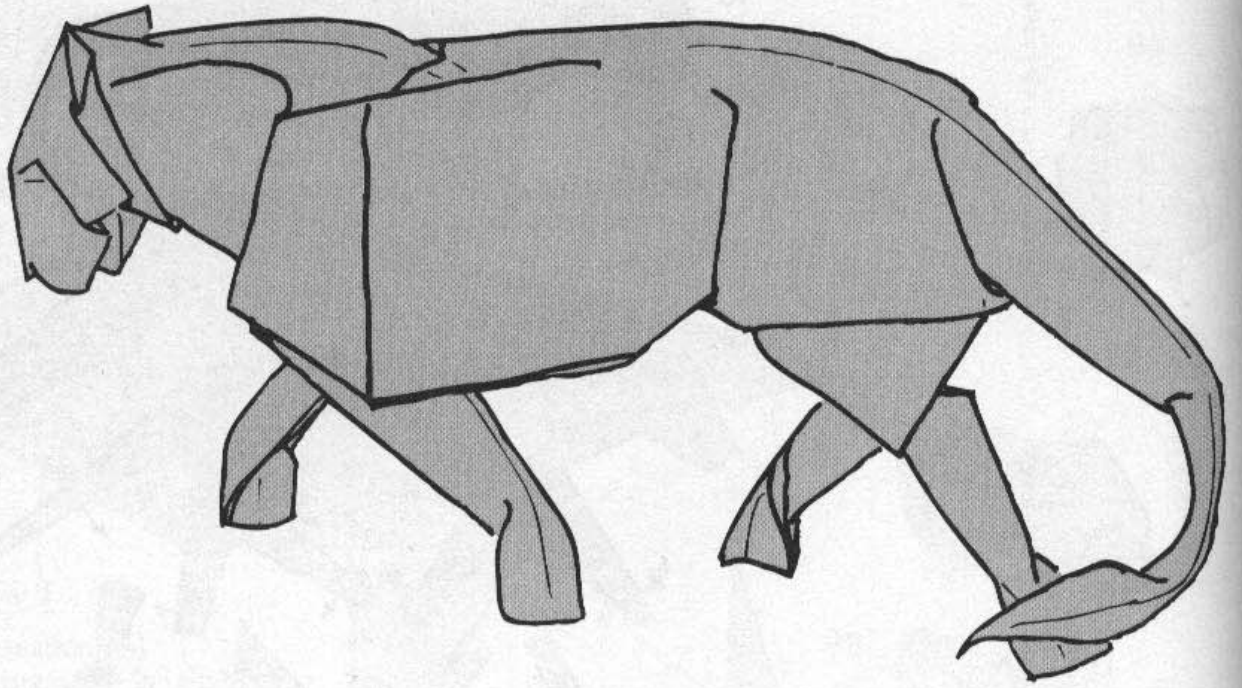

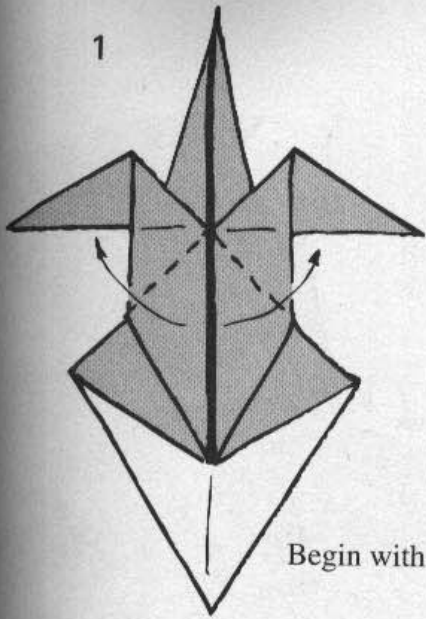

Begin with step 18 of the Lioness

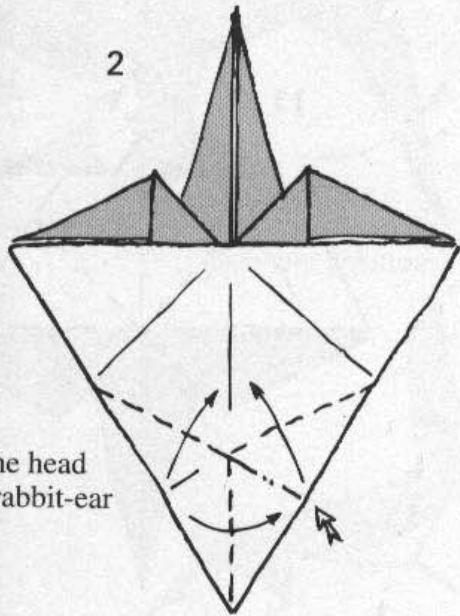
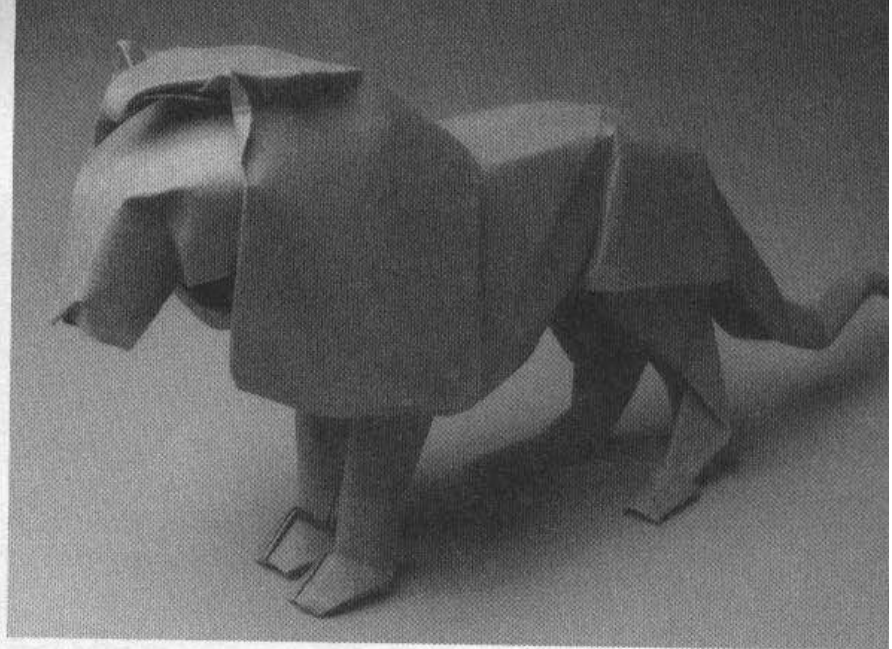

Form the head with a rabbit-ear

Lion

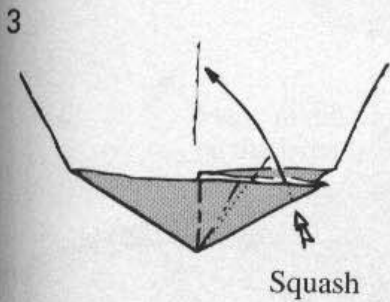
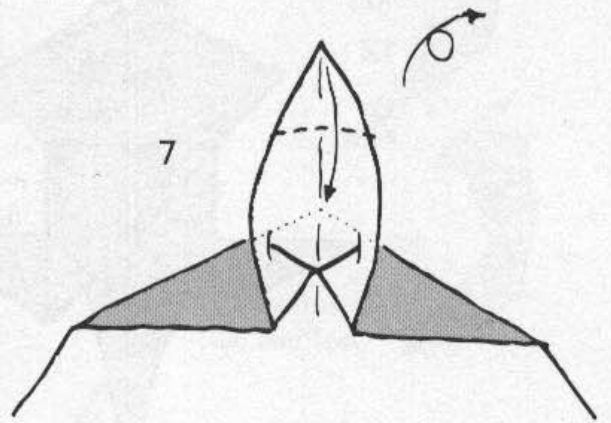

Squash

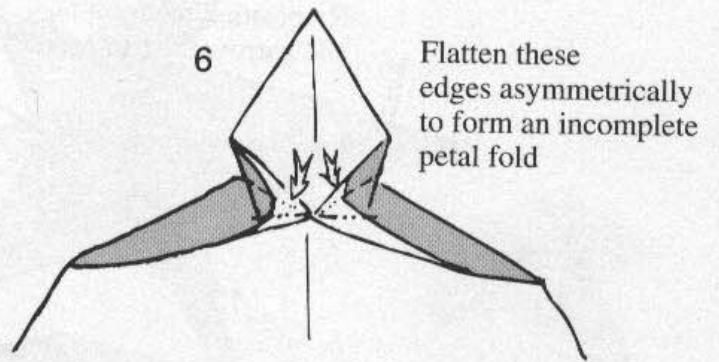

Flatten these edges asymmetrically to form an incomplete petal fold

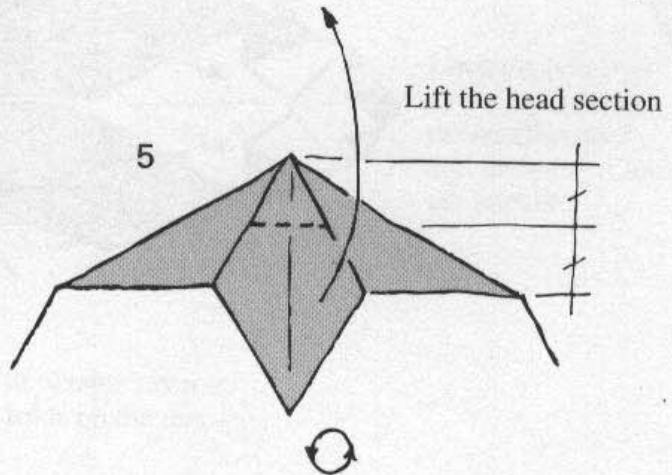
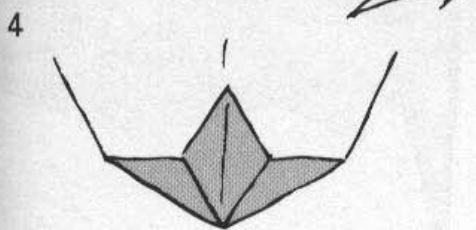

Lift the head section

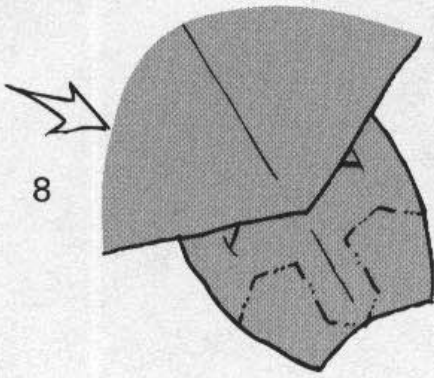

8

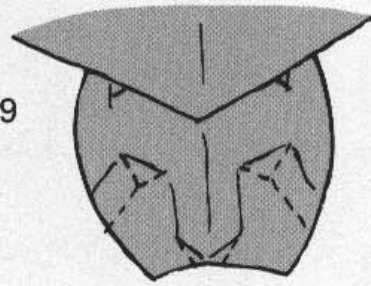

9

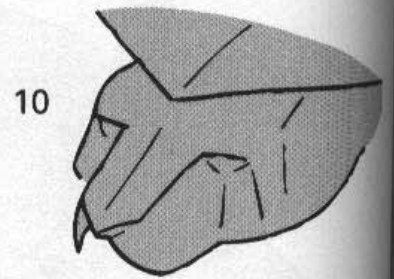

10

Formation of the features
- a similar process to the lioness

12

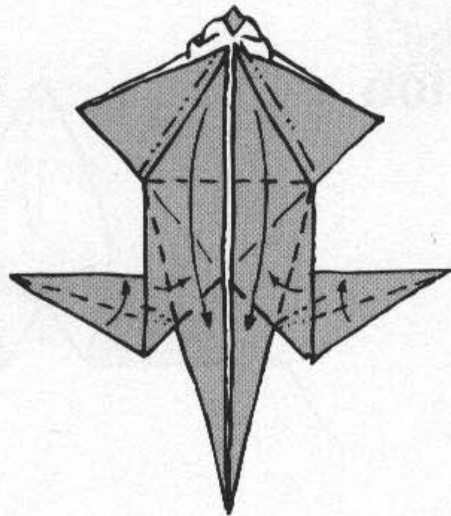

Re-position the front legs
and narrow the rear legs

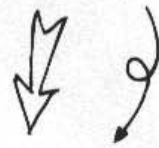

11

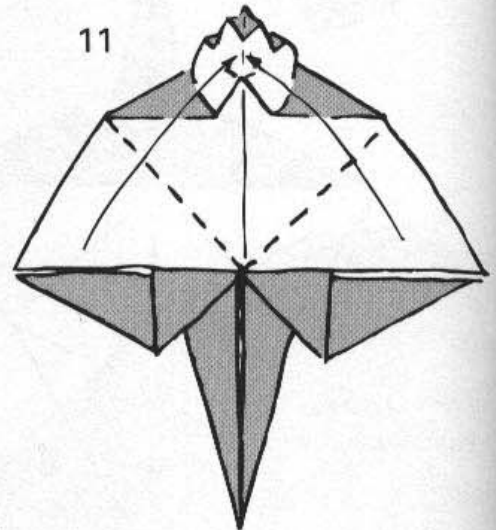

13

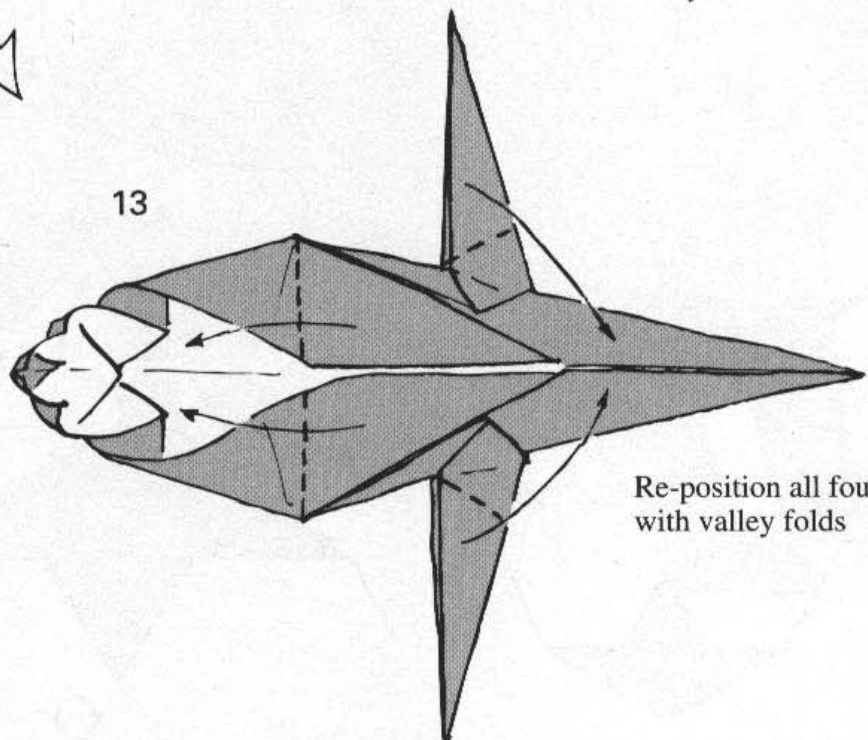

Re-position all four legs
with valley folds

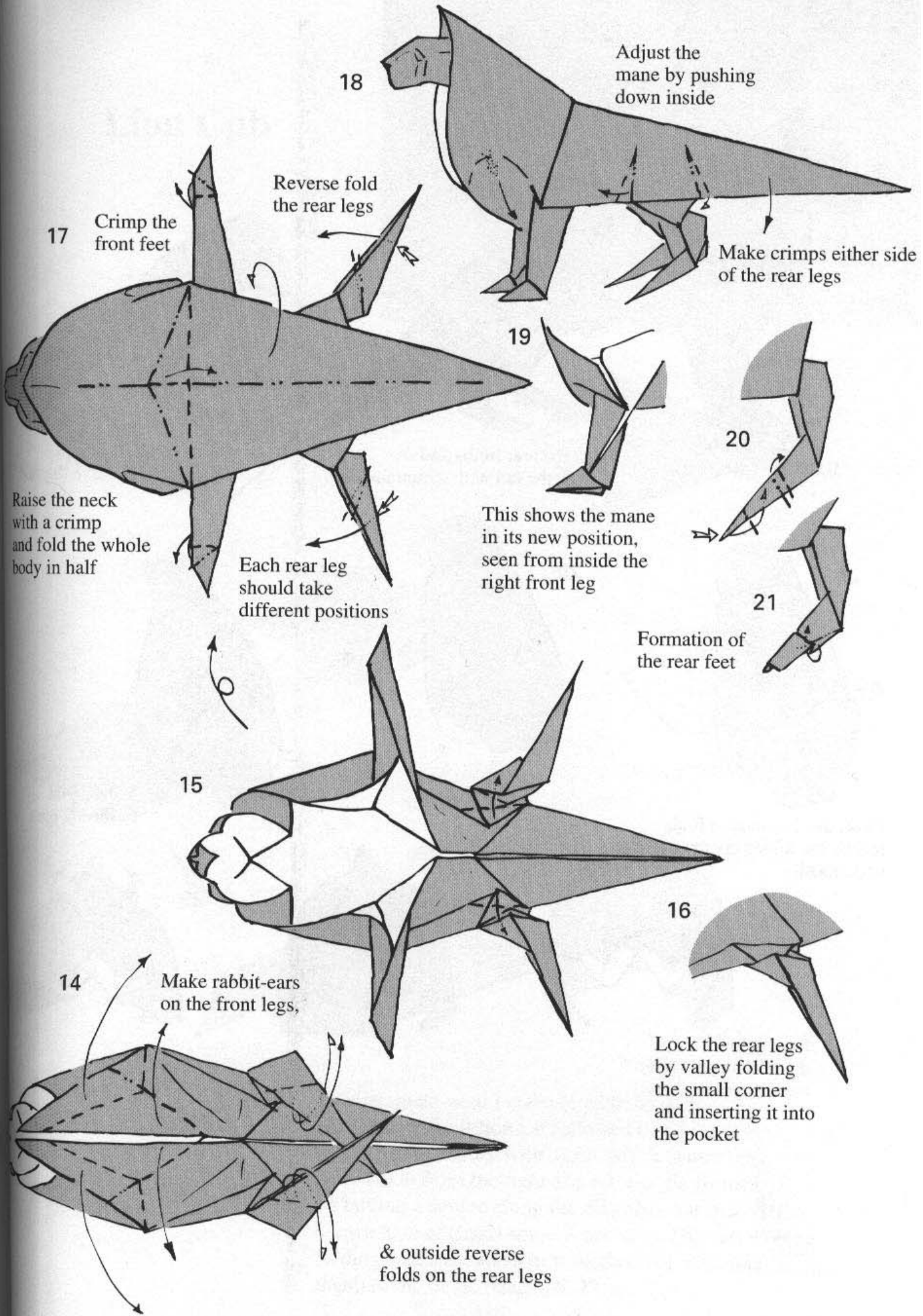

17 Crimp the front feet

Reverse fold the rear legs

18

Adjust the mane by pushing down inside

Make crimps either side of the rear legs

Raise the neck with a crimp and fold the whole body in half

Each rear leg should take different positions

This shows the mane in its new position, seen from inside the right front leg

20

21

Formation of the rear feet

15

16

14

Make rabbit-ears on the front legs,

Lock the rear legs by valley folding the small corner and inserting it into the pocket

& outside reverse folds on the rear legs

22

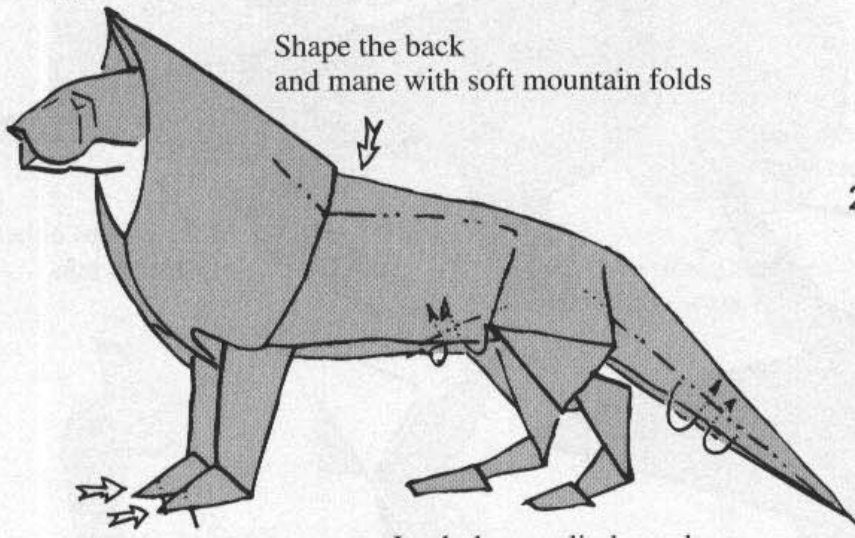

Shape the back and mane with soft mountain folds

Blunt the front feet

Lock the rear limbs and narrow the tail with mountain folds

23

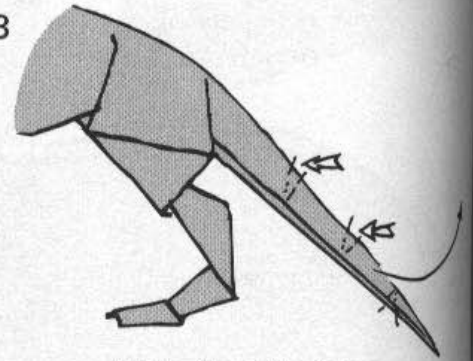

Make 2 small crimps to shape and curve the tail

24

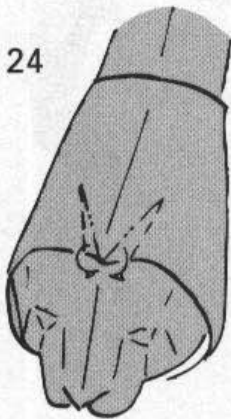

26

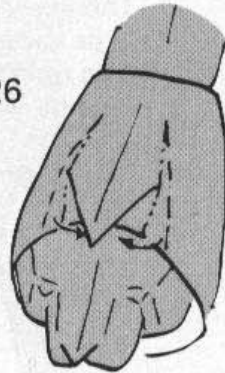

2 more pleats

28



Valley fold to form 2 ears

Pleat: the 2 mountain folds follow the folded edges underneath

25

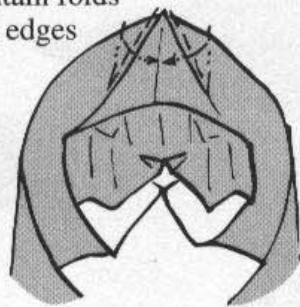

from below: the pleats tuck under the triangular edges

27

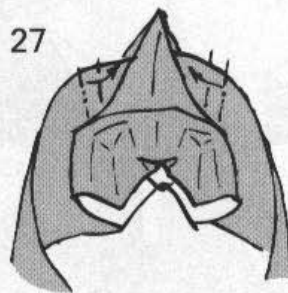

29



Lion Cub

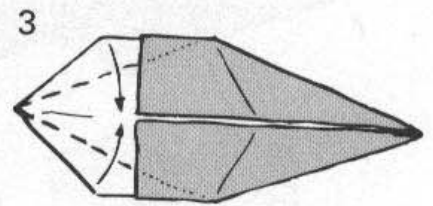
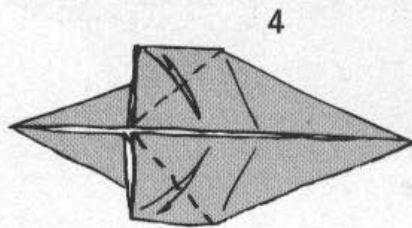
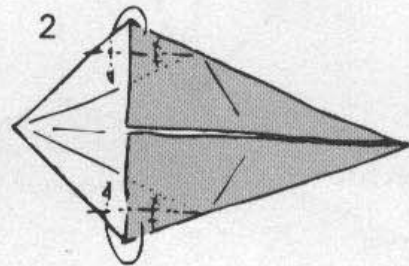
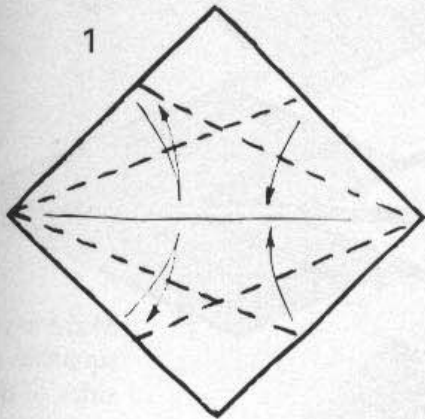
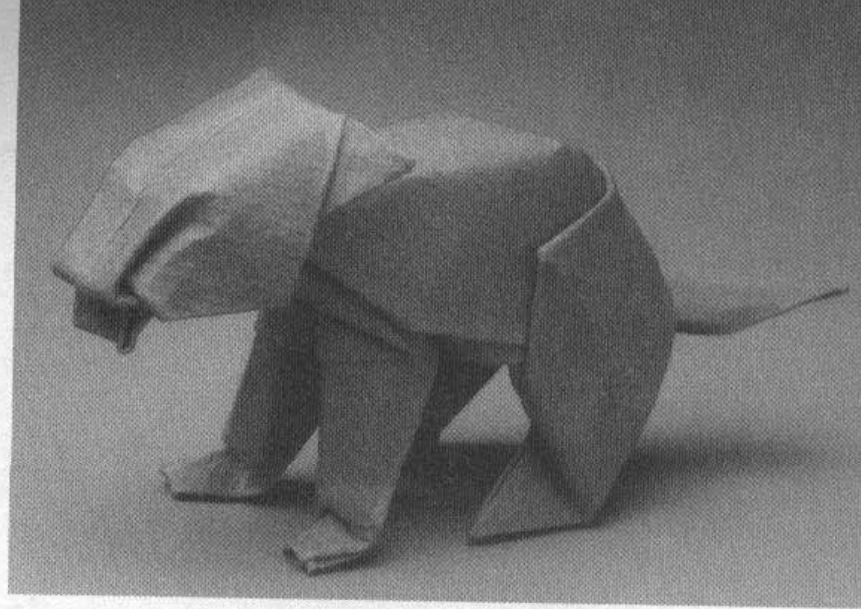

Valley fold within the layers

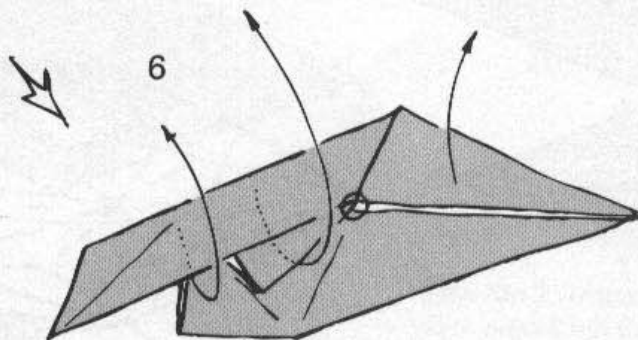
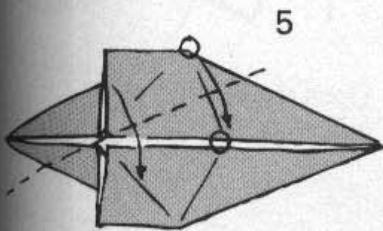

Open up the upper half of the square

Having made what I considered to be quite satisfactory adult lions, it followed that I should complete the family with a cub. My first attempts were made from the right-angled triangle formed by cutting a square along the diagonal, but the version shown here emerged some years later. This has a better folding sequence and a new method for obtaining depth to the body. (steps 26, 27 and 28).

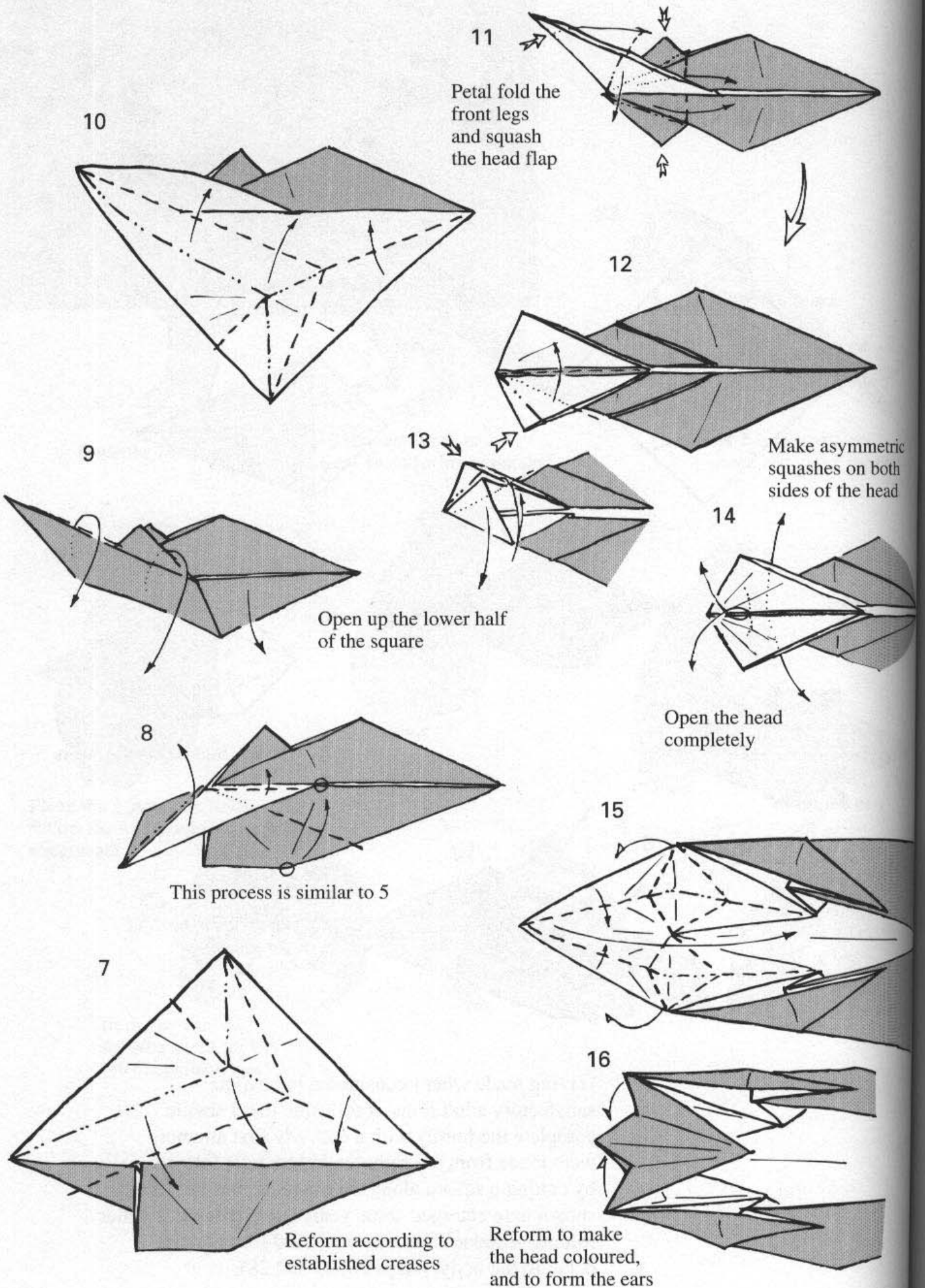

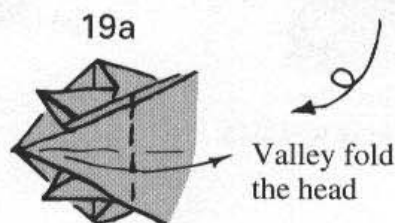
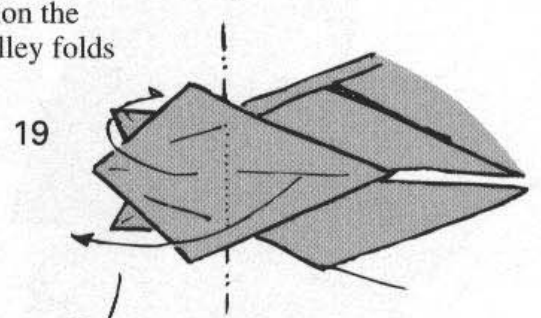
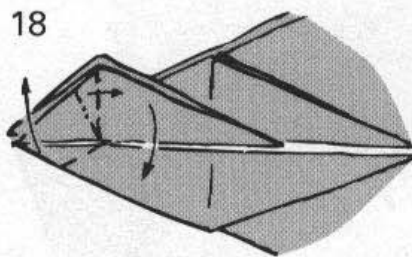
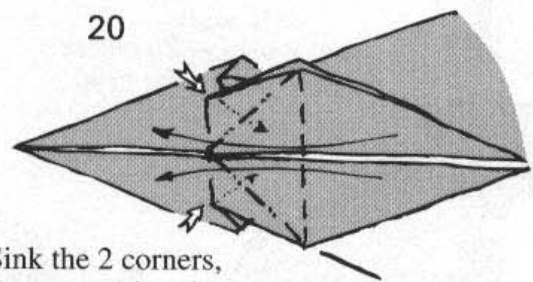
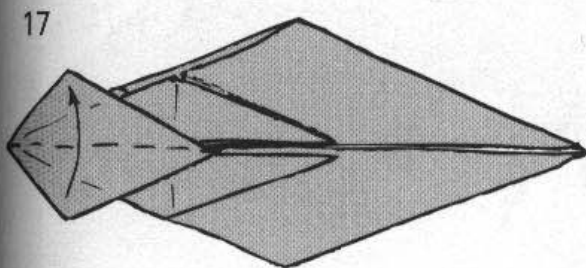
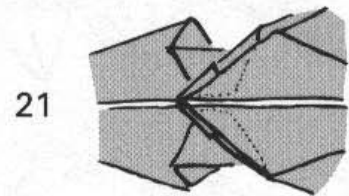
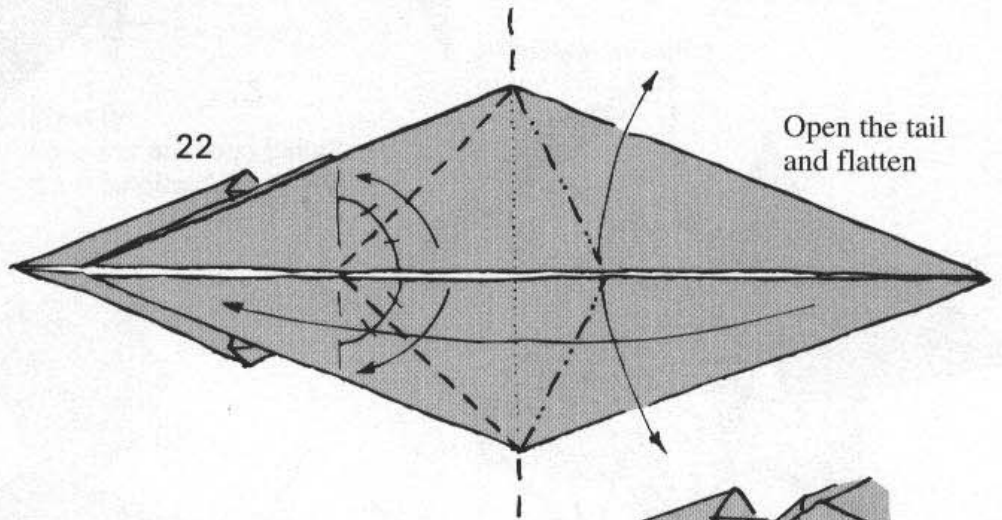
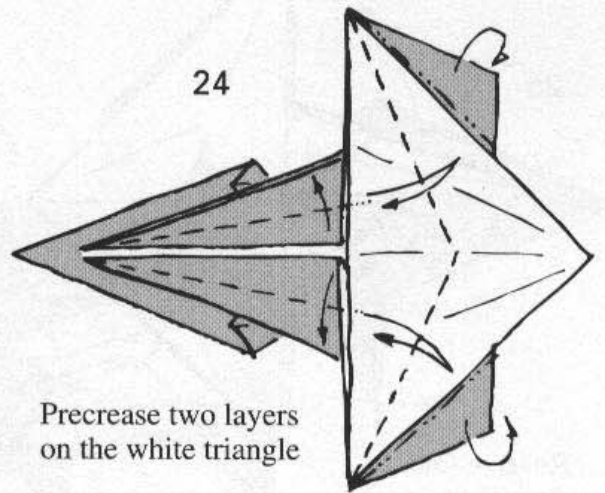
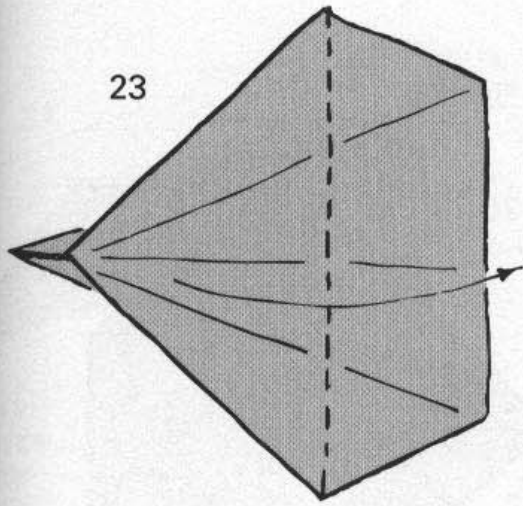

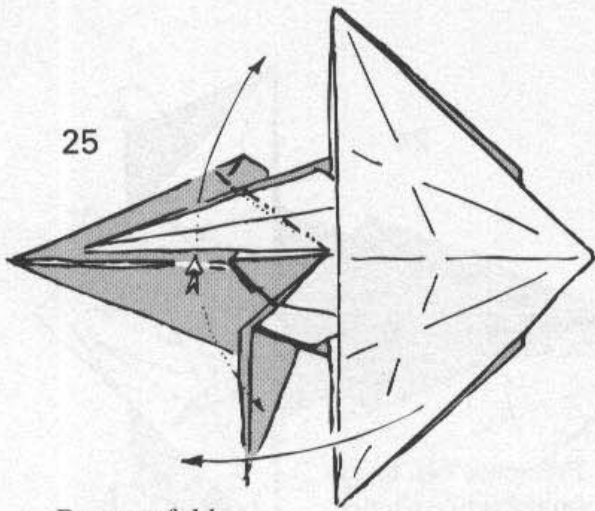

25

Reverse fold
the two front legs

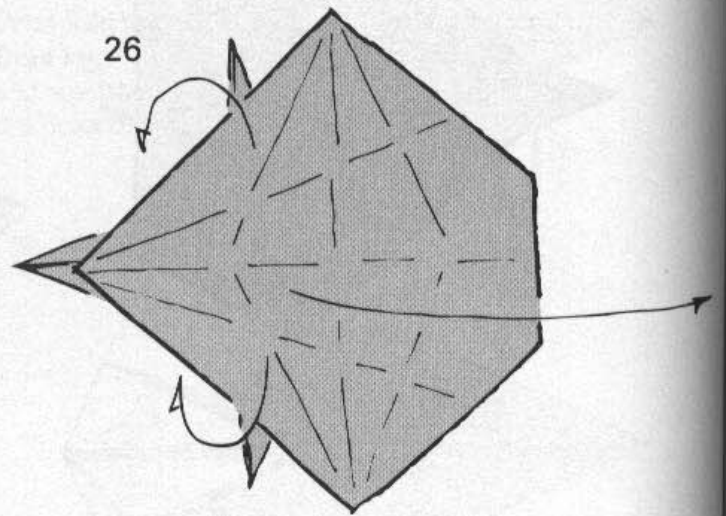

26

Swing open the
whole tail section

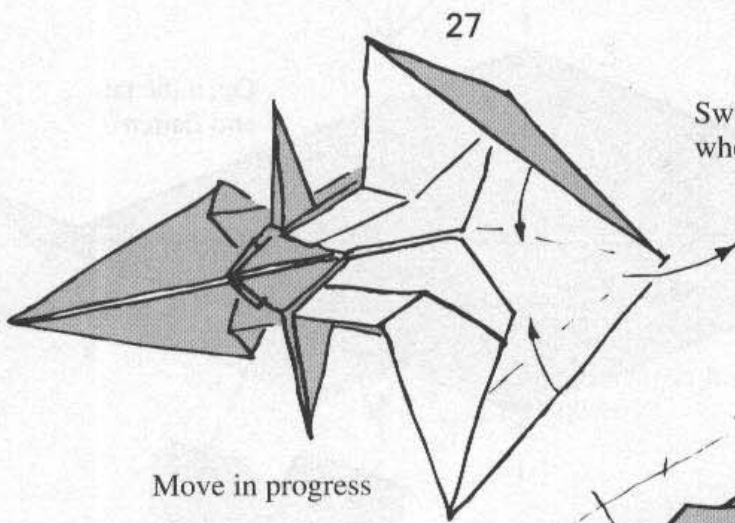

27

Move in progress

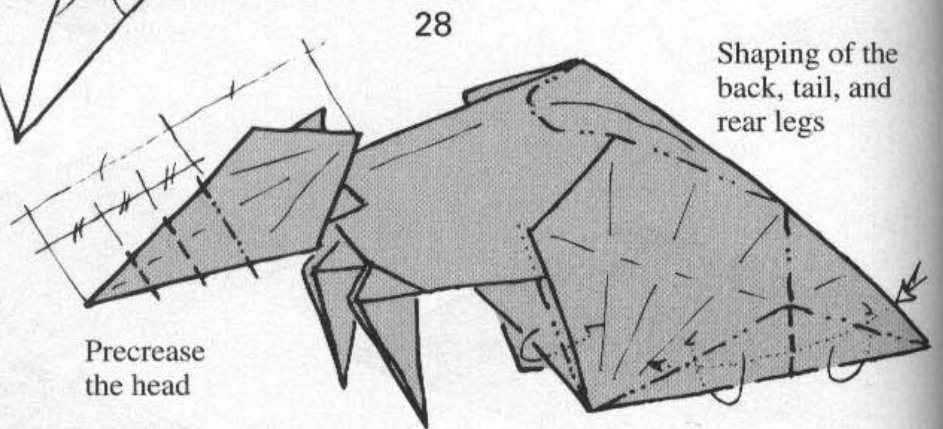

28

Shaping of the
back, tail, and
rear legs

Precrease
the head

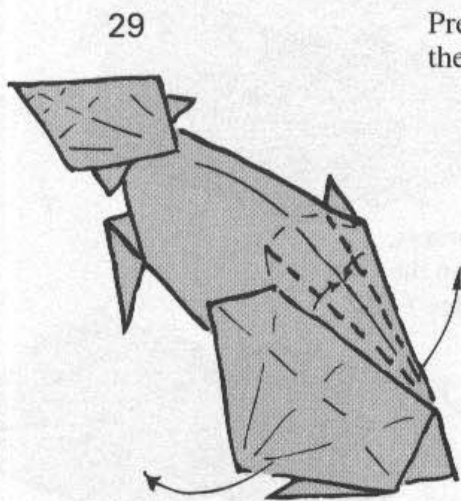

29

Pleat the back
to lock the 3D
shape: allow the
legs to swing upwards

30

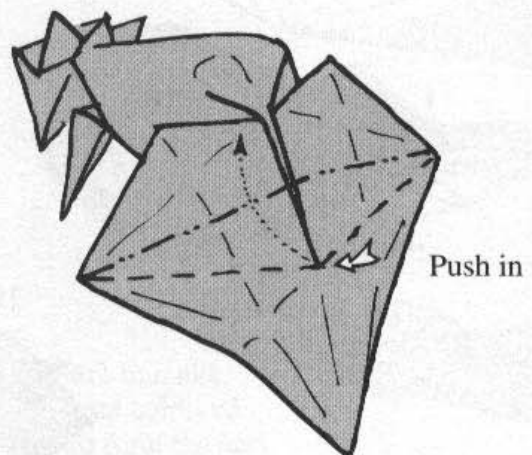

Push in

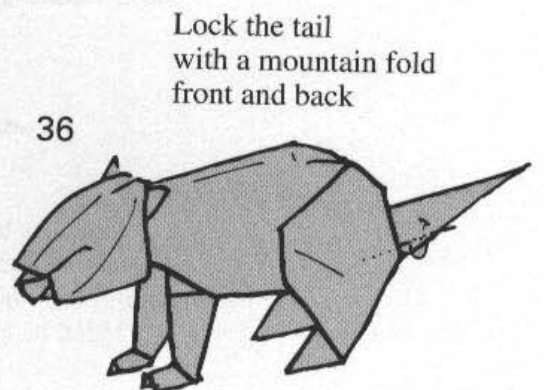
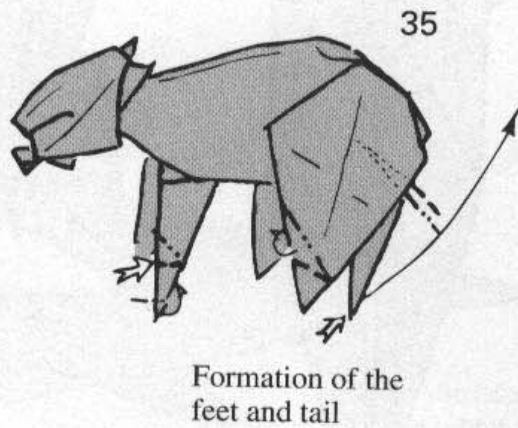
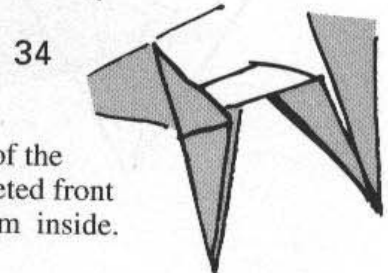
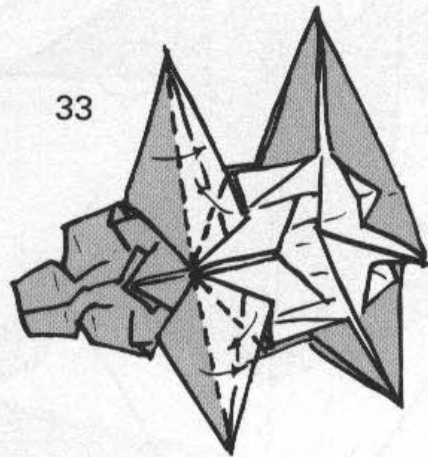
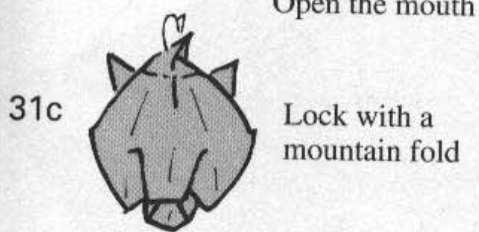
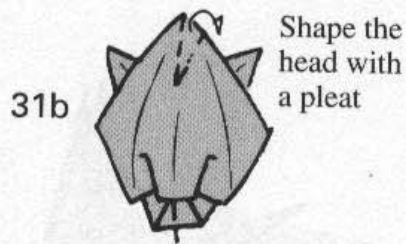
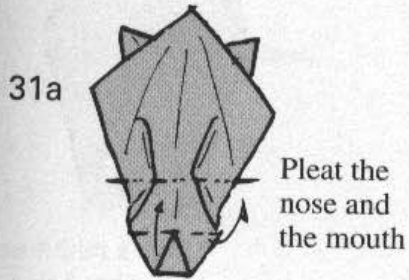
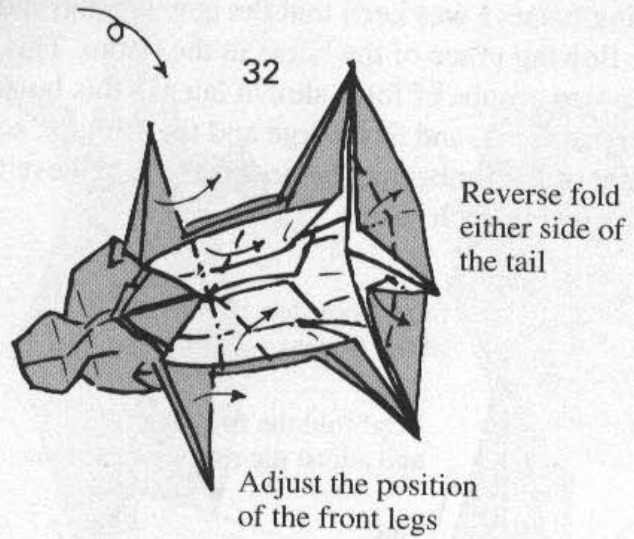
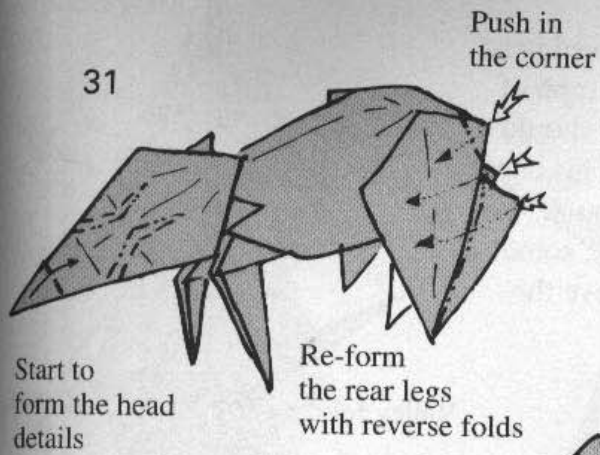

I had made an earlier version of a horse with a bowed head but was prompted to revise it when I saw a photograph of a galloping horse: I was keen that the new version should have the flowing grace of the horse in the photo. This horse is used in two groups of folds shown later in this book: the Showjumper scene, and St George and the Dragon. some adjustment of the limbs may be necessary to achieve the required effect in each case.

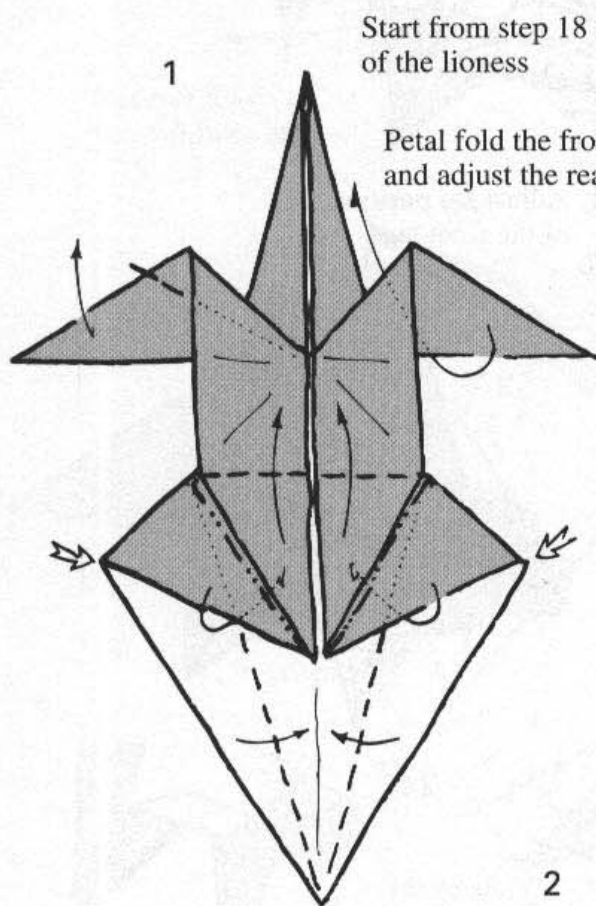

Swivel the left-hand leg and sink the right-hand leg



Horse

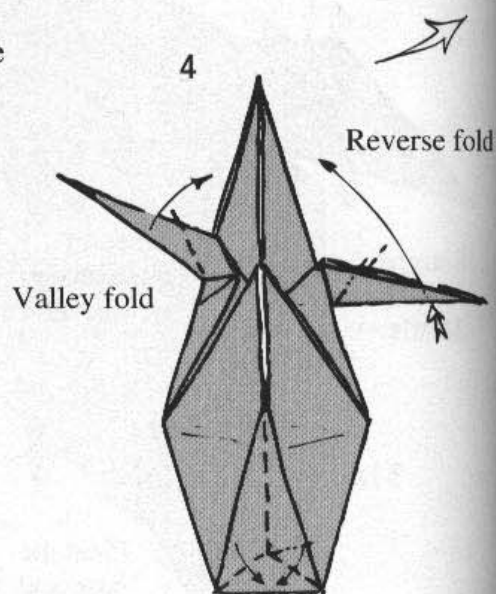

Make a rabbit-ear on the head flap

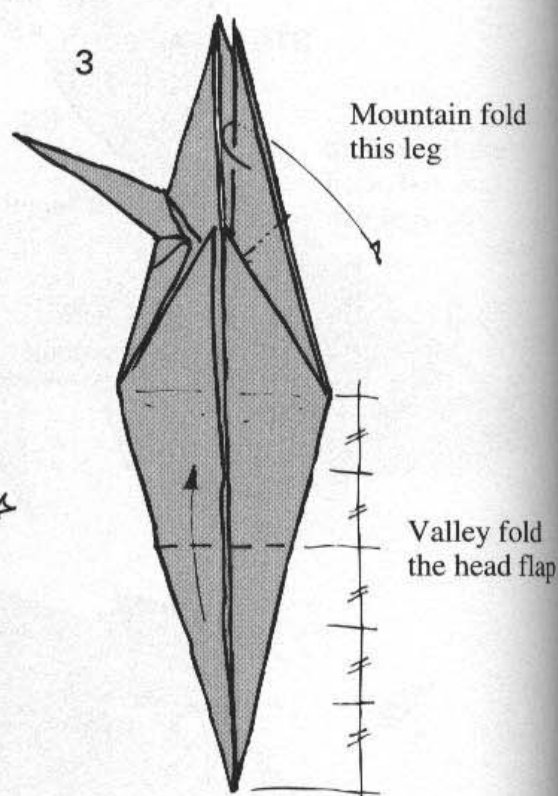

Outside reverse fold

5

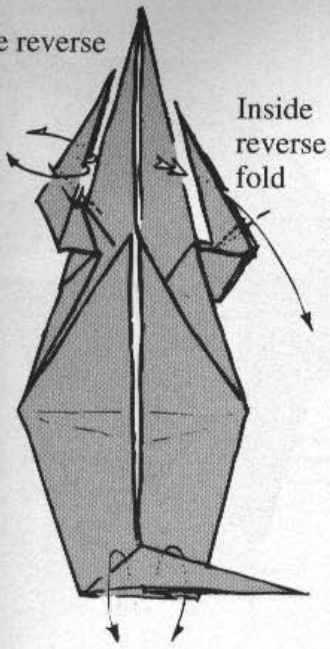

Release layers
each side of
the head flap

6

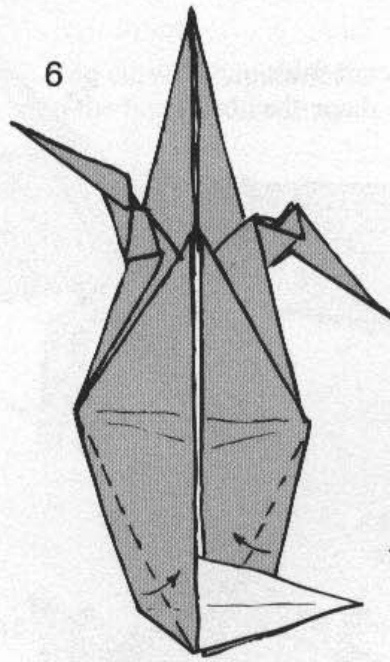

Valley fold
to narrow the ears

7

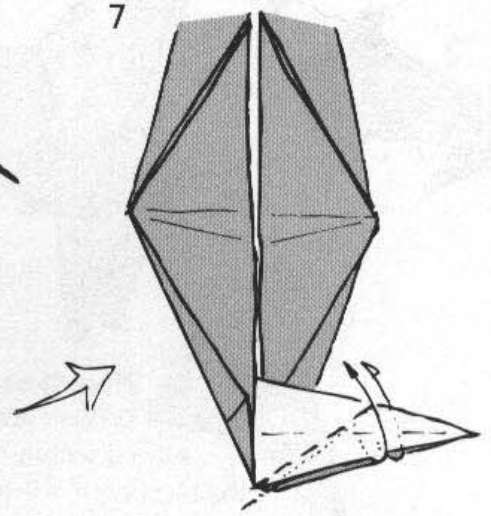

Outside reverse fold
to make the tip of the
head flap lie along
the edge of the neck

8

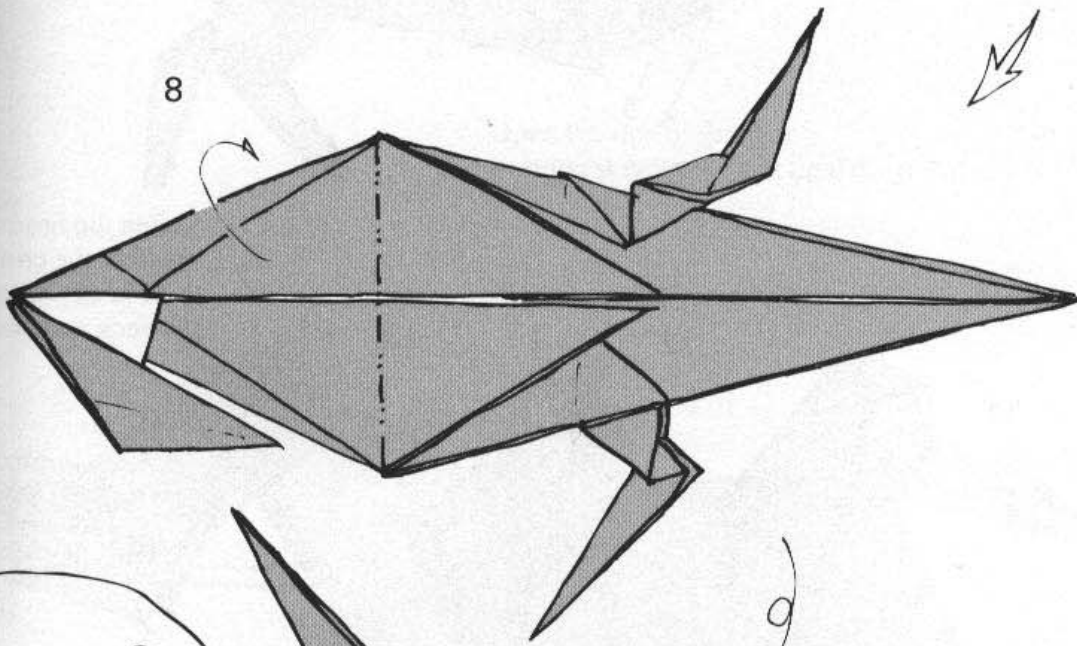

9

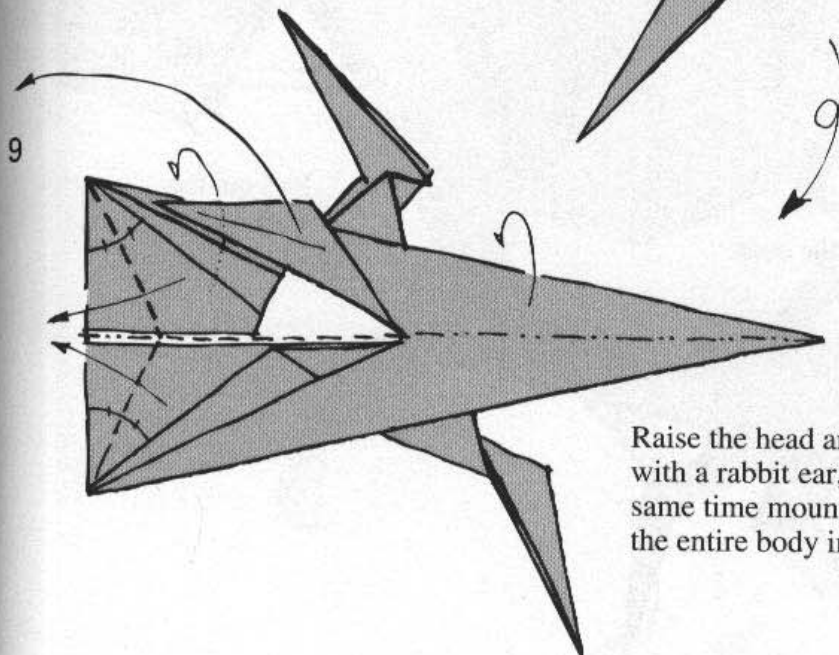

Raise the head and neck
with a rabbit ear, at the
same time mountain folding
the entire body in half

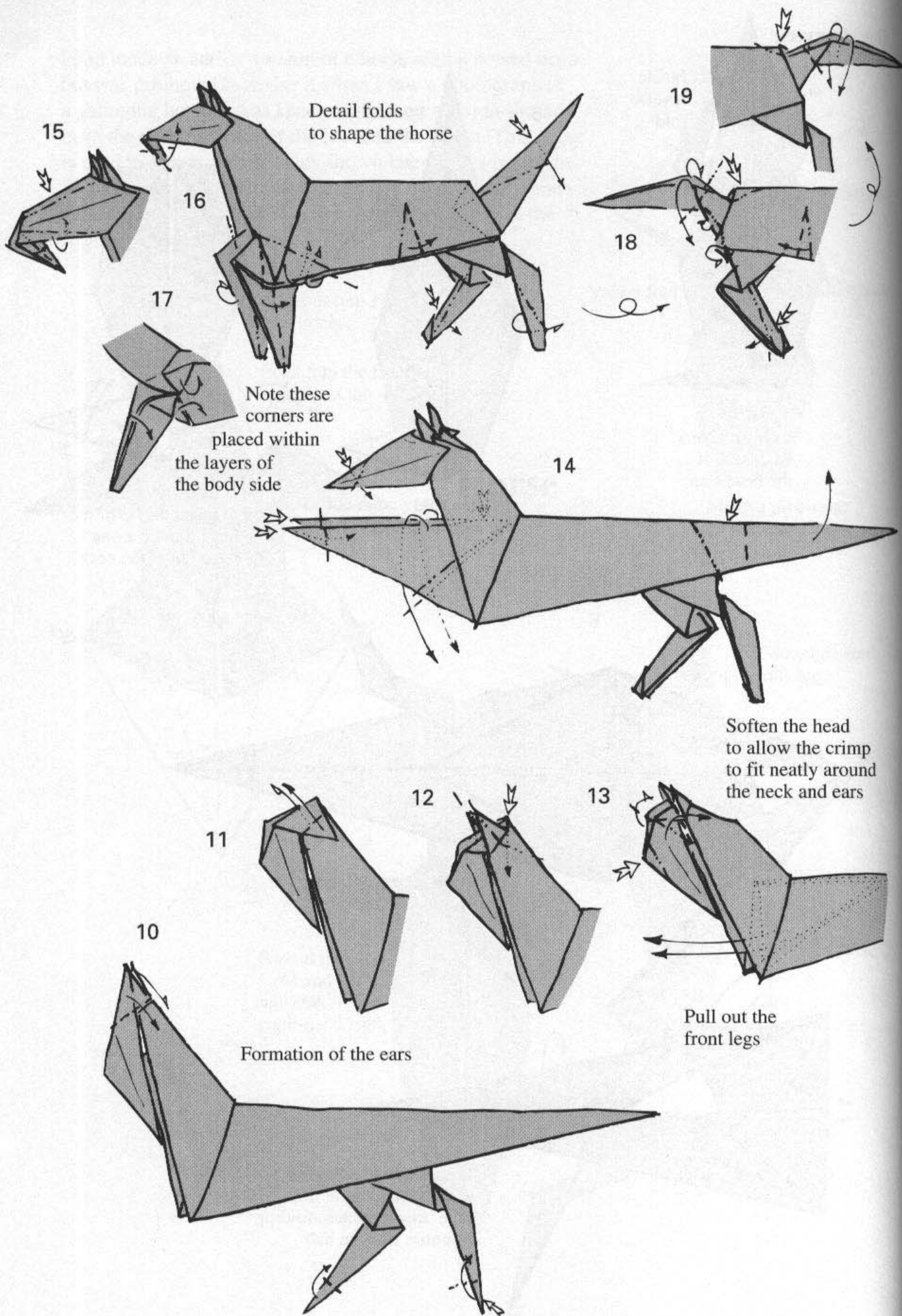

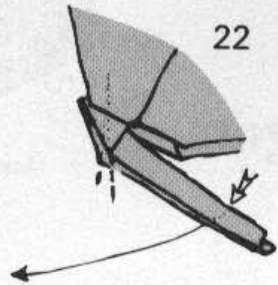
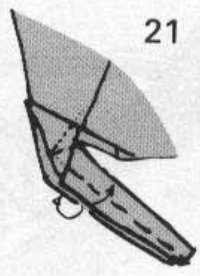
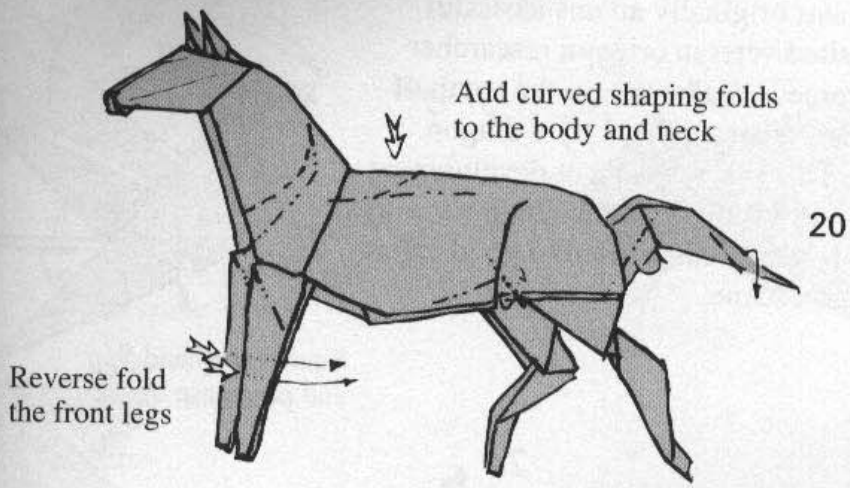

Narrow the front legs then reverse fold the left hand leg. The right hand leg can remain pointing backwards

Open the tips of the feet to suggest hooves. (see final diagram)

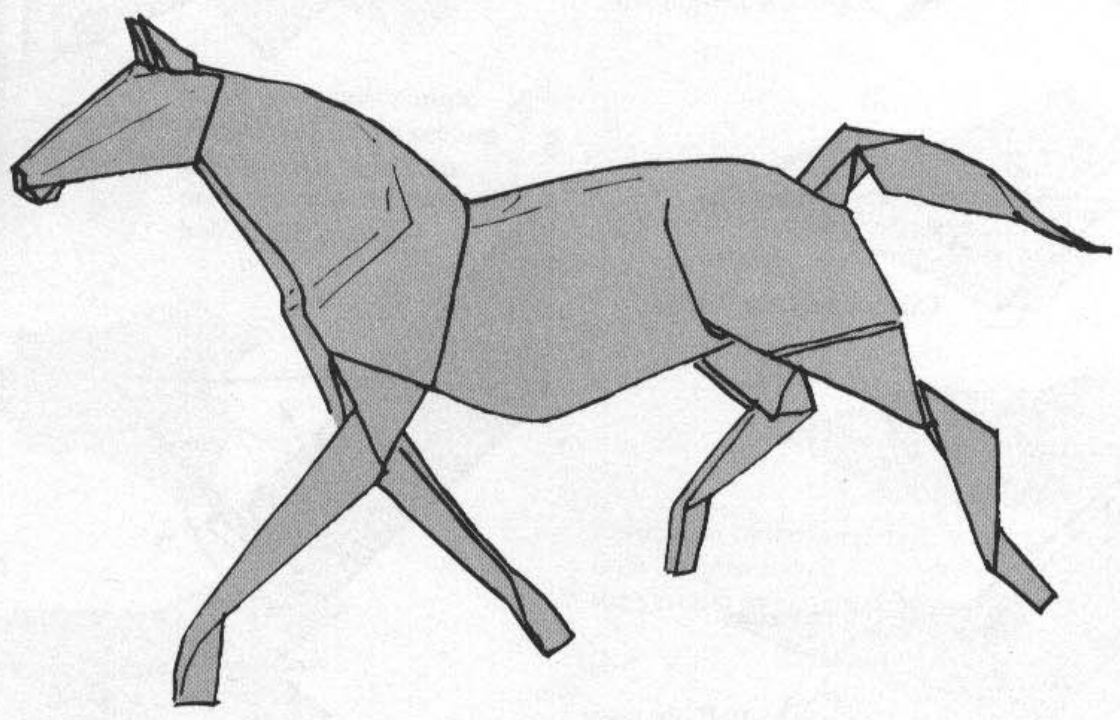

The basis for this design was originally an unsuccessful experiment for a cat! I visited veteran origami researcher Gershon Legman at his home in Valbonne, in the south of France in August 1982: he suggested that I try a dragon with a three-pronged tail. This is a subsequent development with a single point at the tail. I found that the Dragon's wings flapped by accident. The twisted head is used to good effect in the St George and Dragon scene.

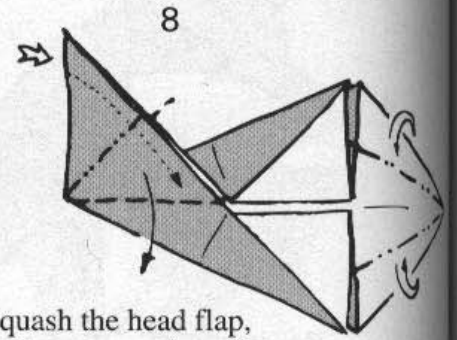

Squash the head flap, and precrease the tail

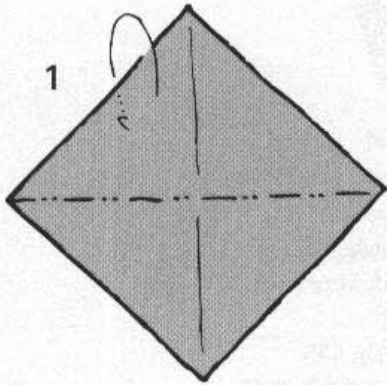

Start with a large square at least 12 inches (30 cm) each side

Dragon

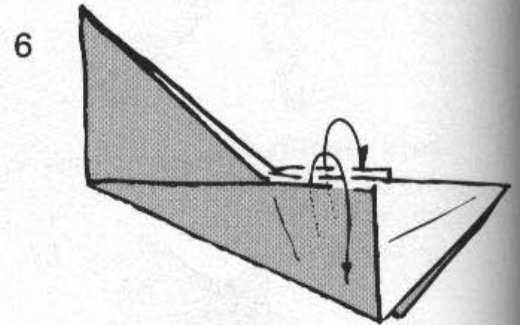
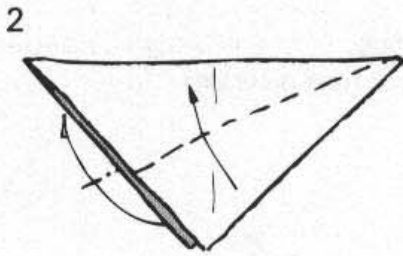
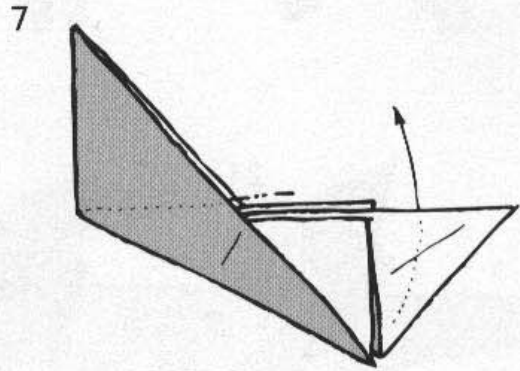

Re-position the layers from inside

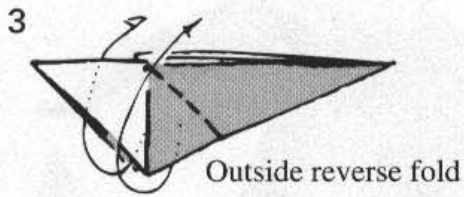

Outside reverse fold

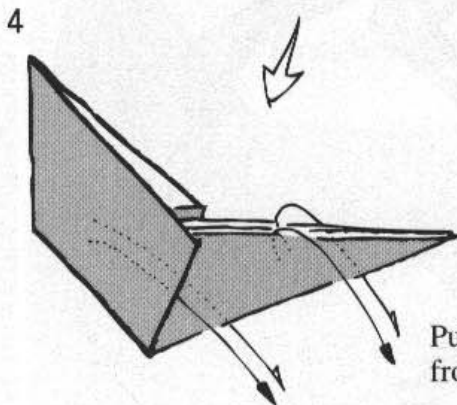
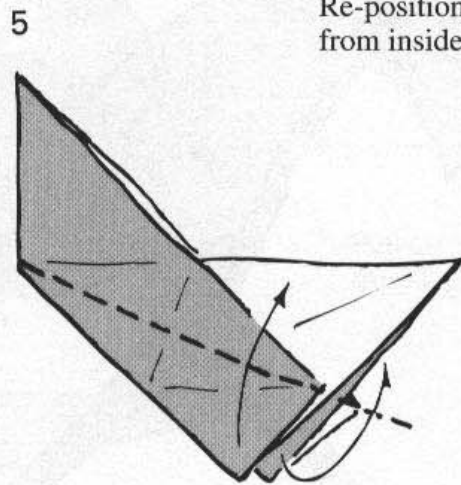

Pull out layer from each side

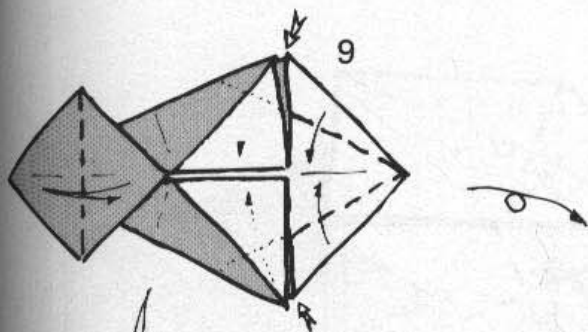

Reverse fold the tail at either side

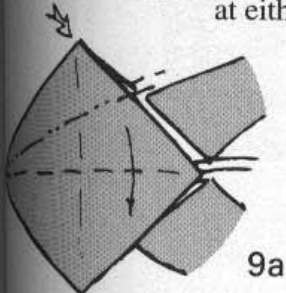

Squash

9a

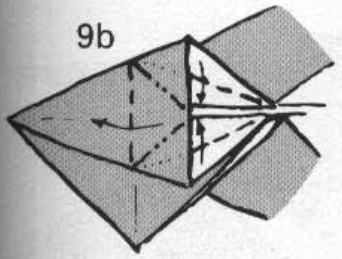

and petal

9b

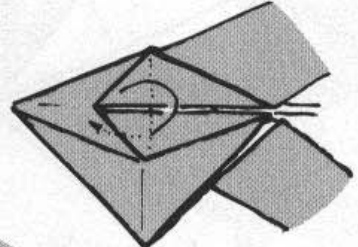

Turn the small triangle inside

9c

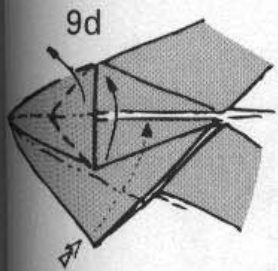

Raise the small triangle while folding this section in half, then repeat the previous steps on the lower half of the head

9d

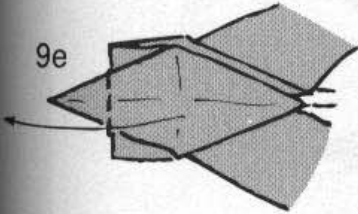

9e

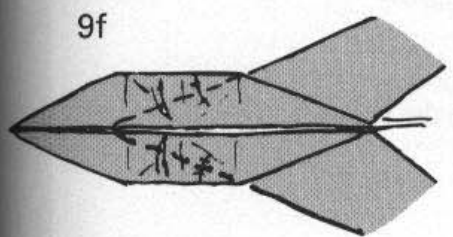

9f

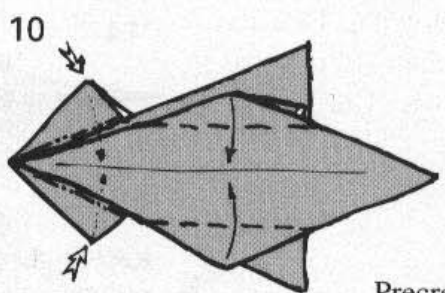

Precrease, then sink

10

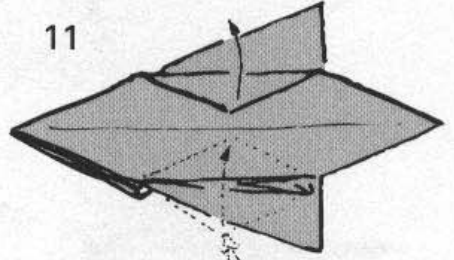

11

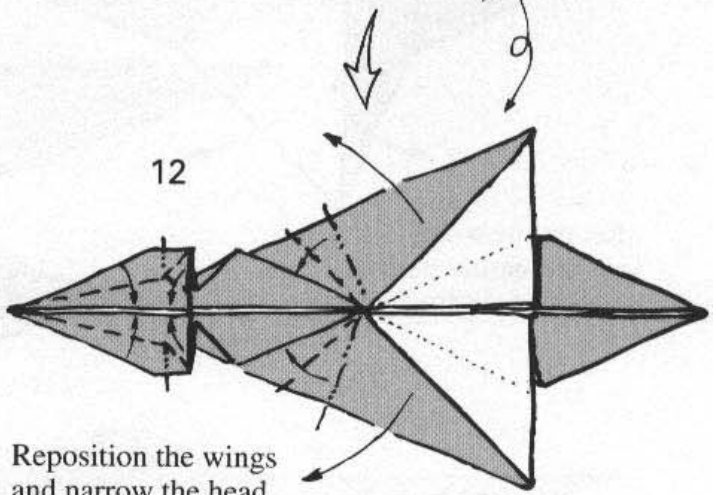

Reposition the wings and narrow the head

12

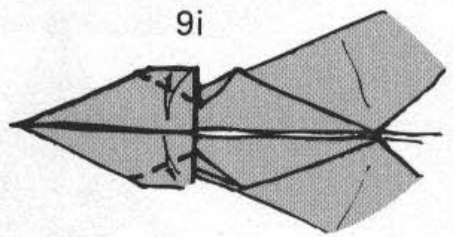

9i

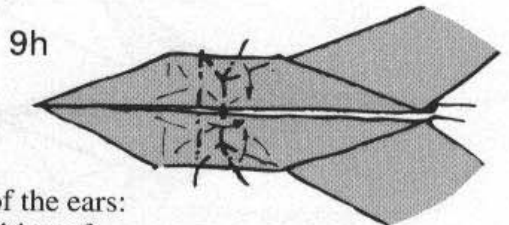

9h

Formation of the ears: note the position of the vertical mountain fold

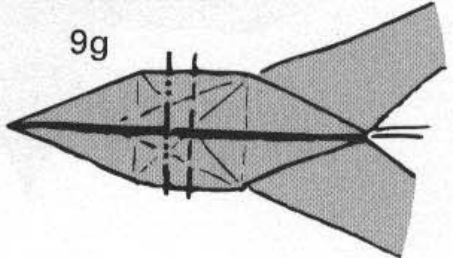

9g

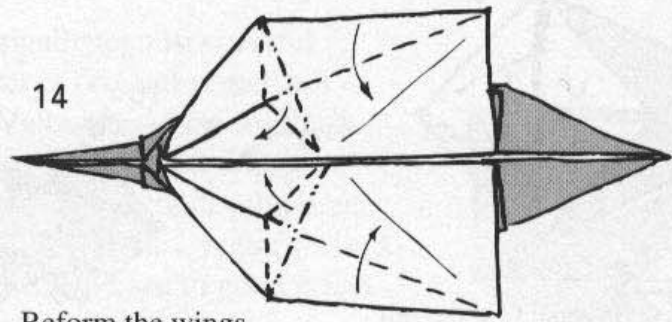

14
Reform the wings following these creases

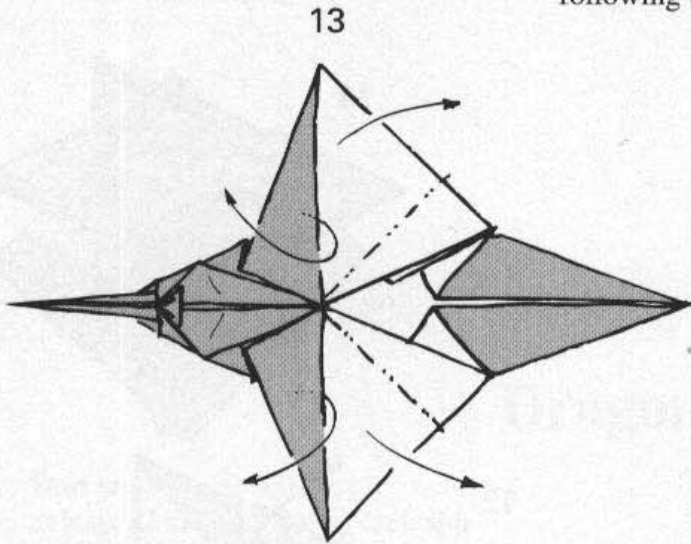

13
Return the wings to their earlier position and open the front edges

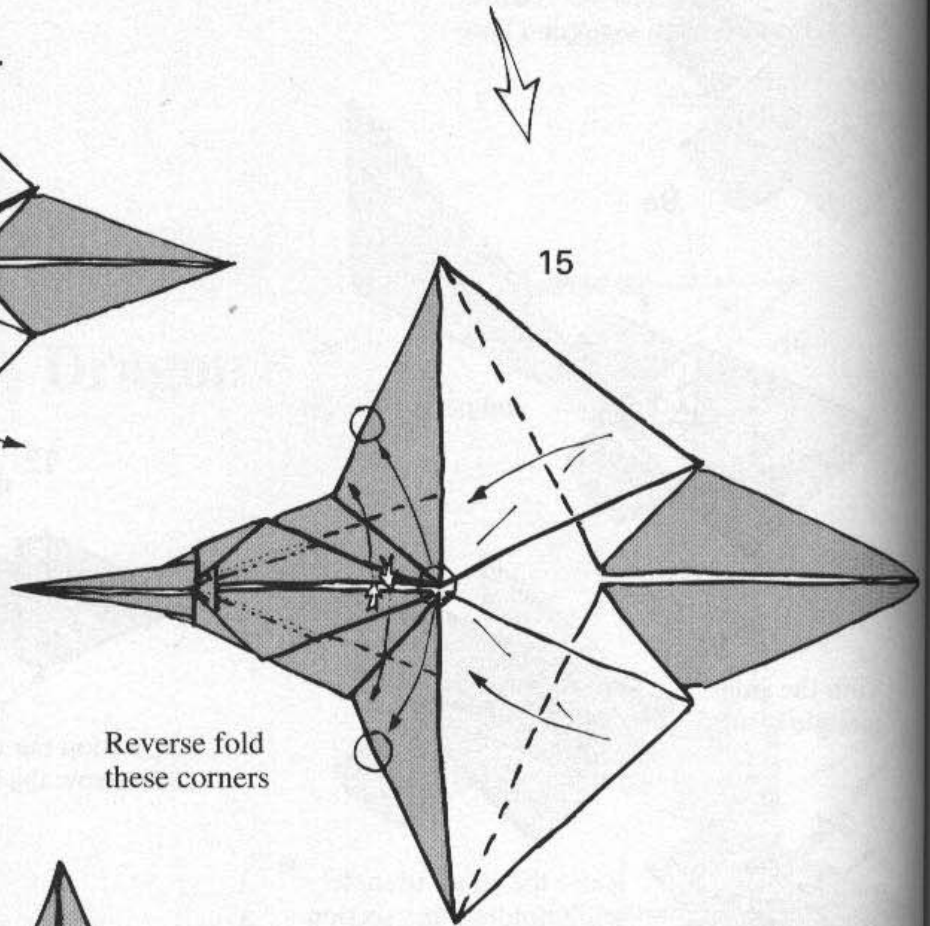

15
Reverse fold these corners

Valley fold the rear edges of the wings

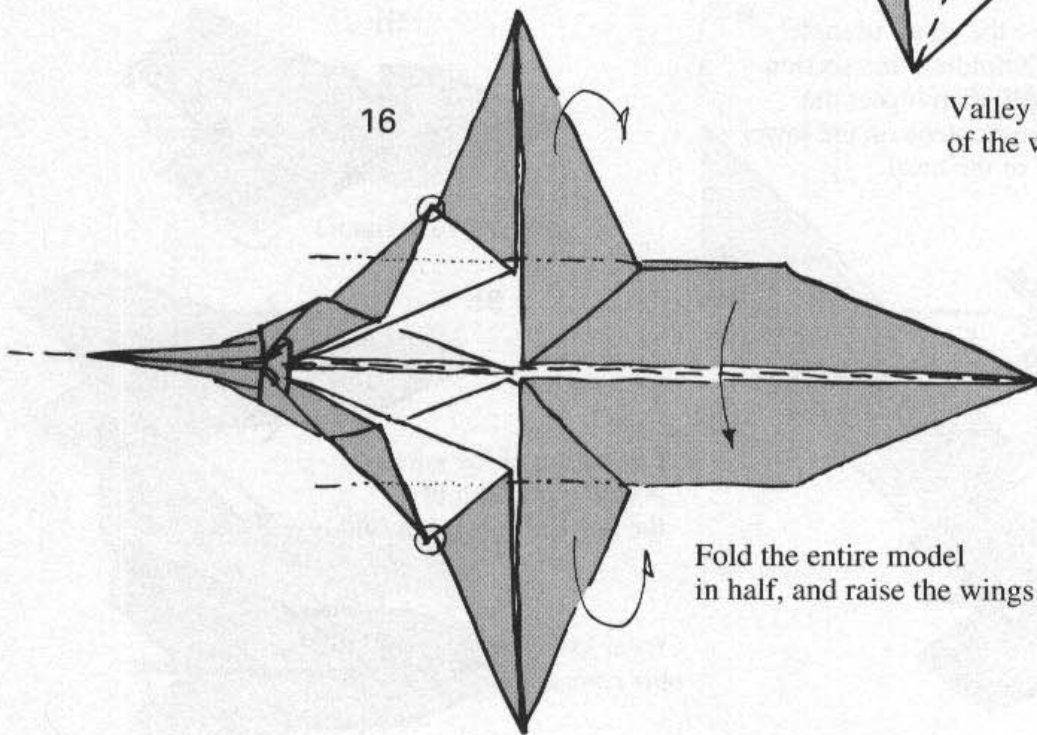

16
Fold the entire model in half, and raise the wings

22

Reform the front legs and press flat

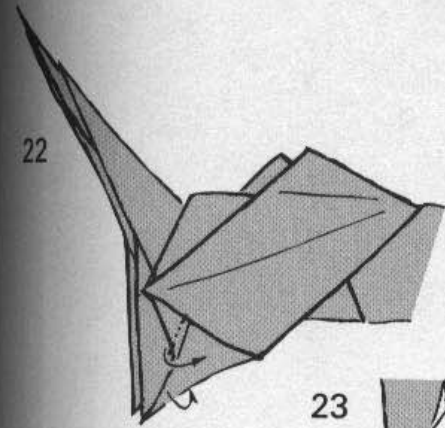

24

Outside reverse fold the neck

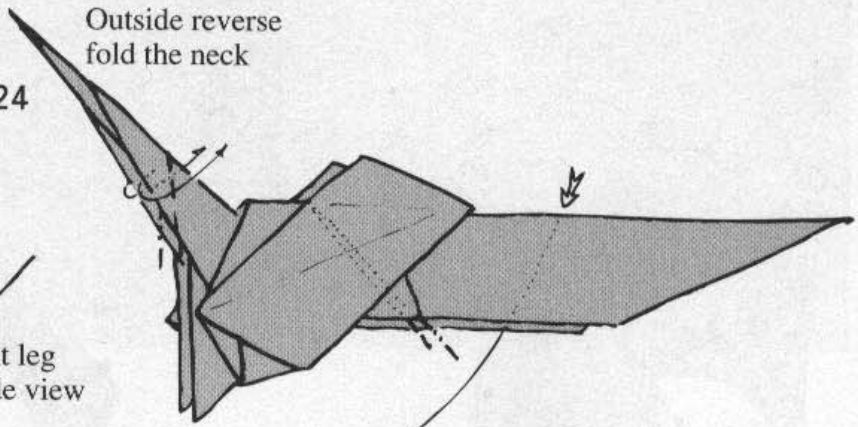

23

Front leg inside view

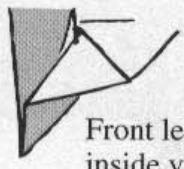

Reverse fold the tail

21

Pull up the neck

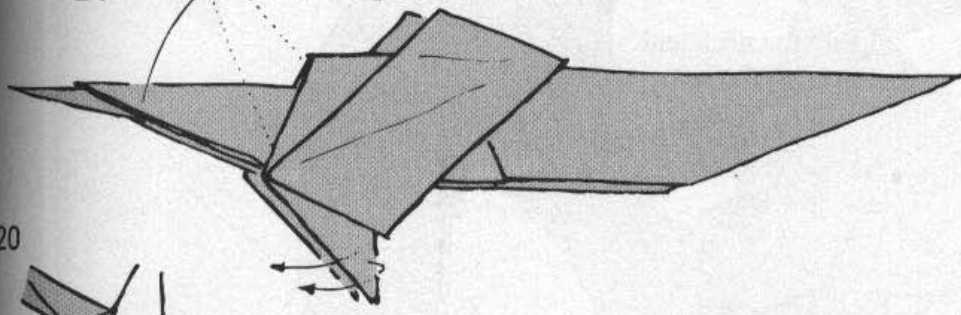

20

Inside of right hand front leg



18

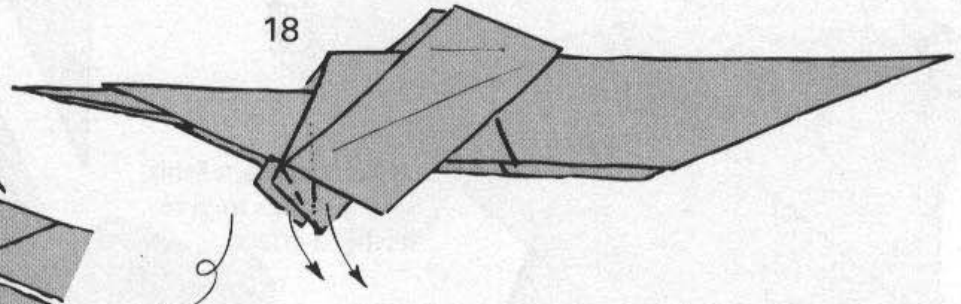

Pull out the front legs and follow these creases to make them lie flat

19

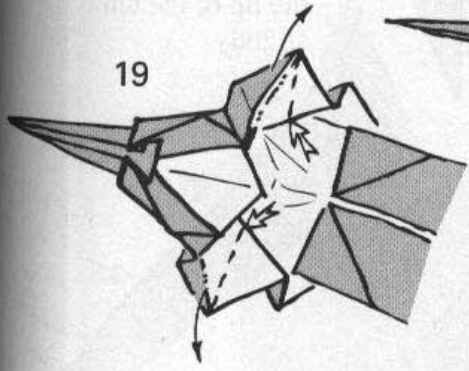

17

Squash the wings and reverse fold the neck in and out

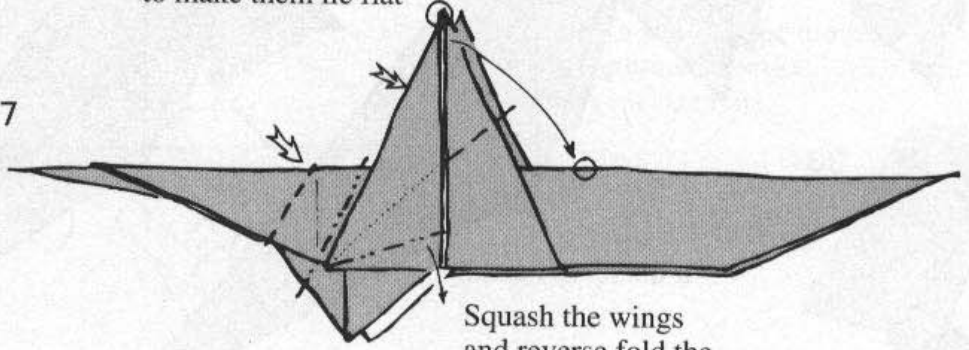

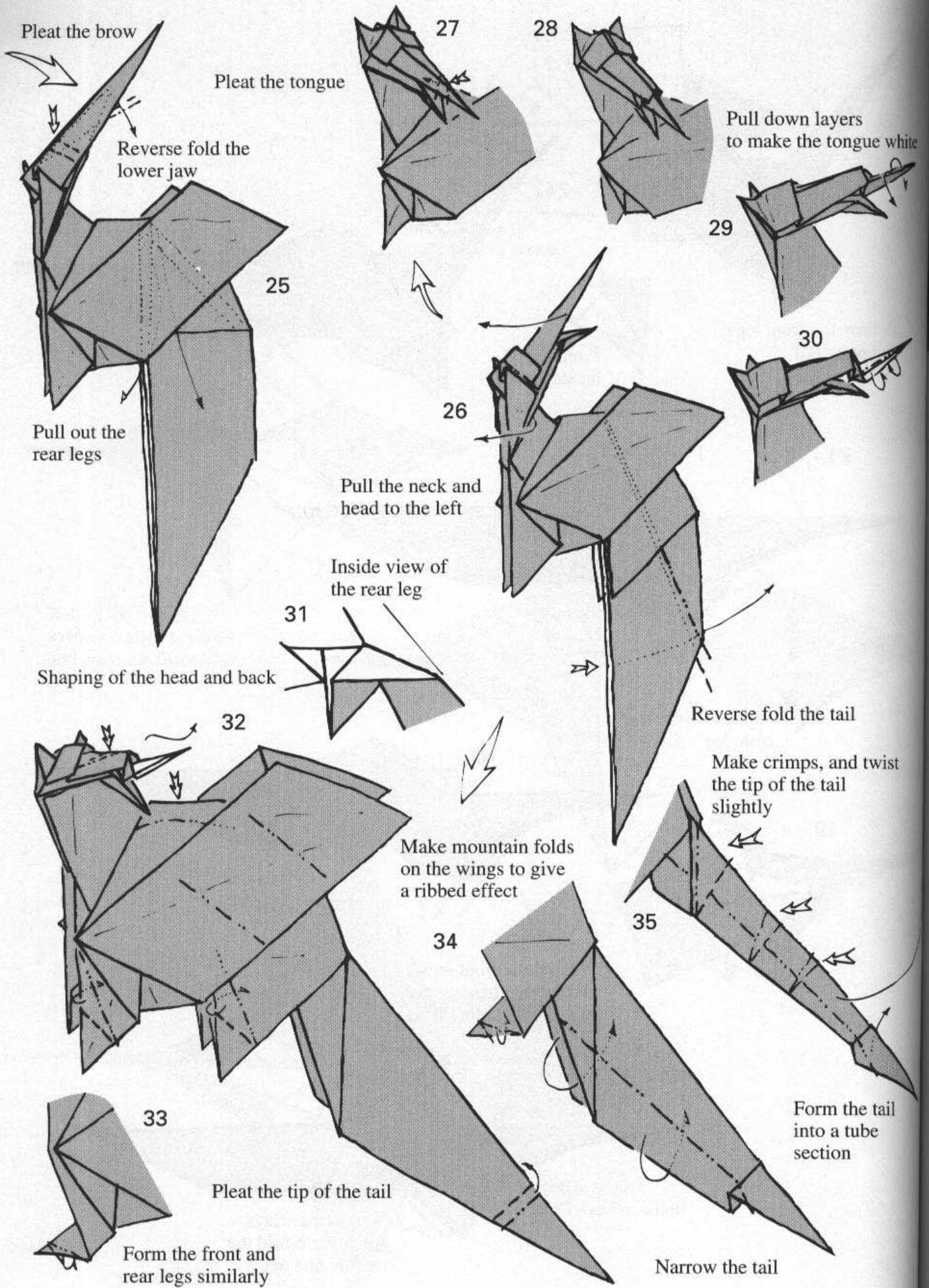

white

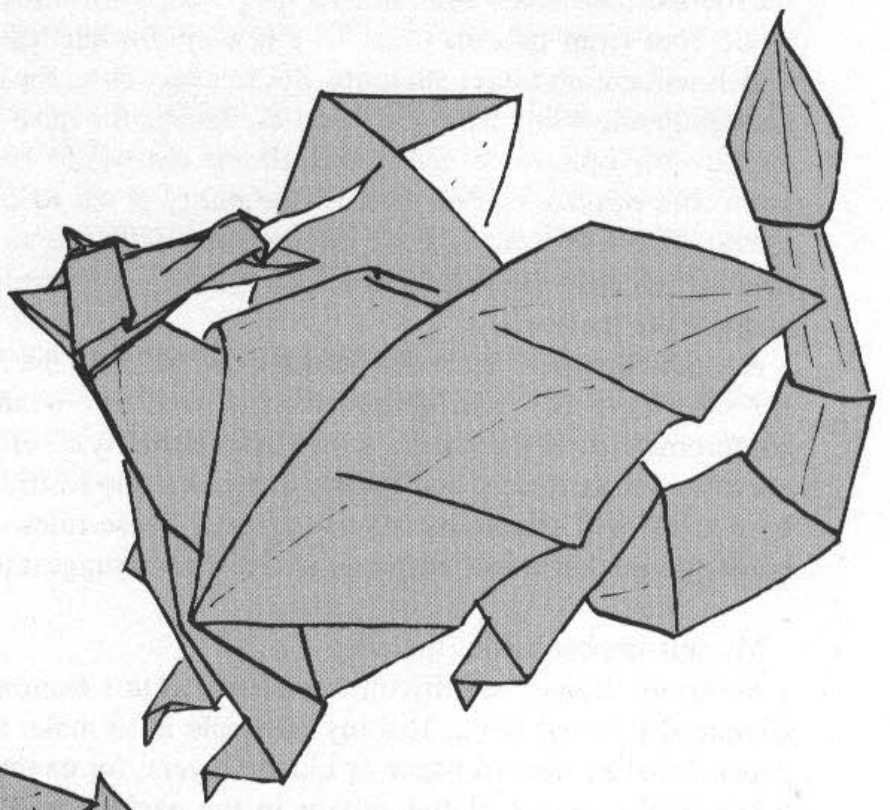
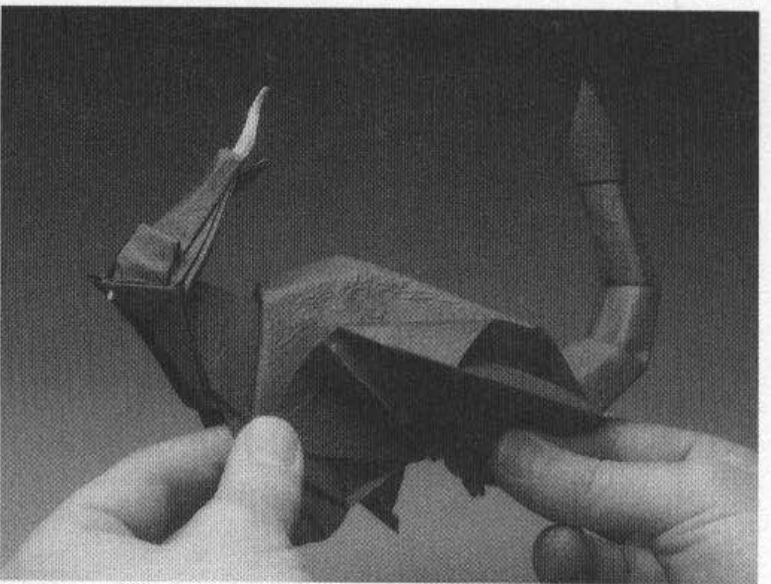
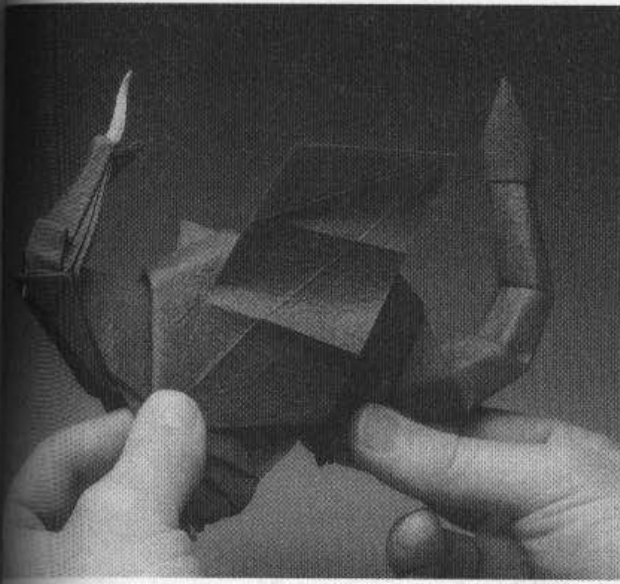

36

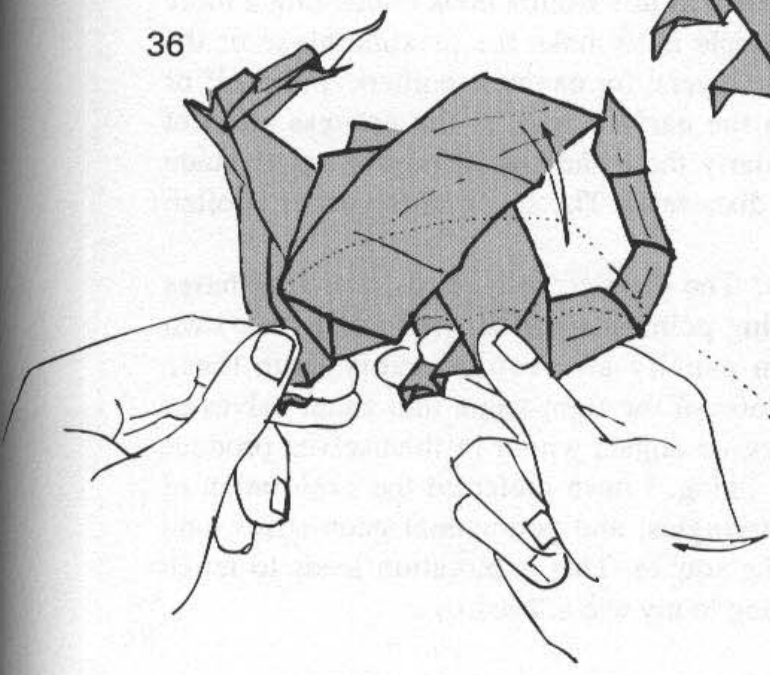

Hold the dragon like this.
The hands should then be moved
apart and returned to make
the dragon's wings flap.

Rules Traditional and Personal

One of the main attractions of origami is the limitations which are understood by the Japanese word: "ORIGAMI = to fold paper. "The logical assumptions which follow form the basis of the traditional rules:

No Cutting, No Gluing, No Decoration.

The restrictions particularly appeal to me: this purest form of origami means that no complicated tools or raw materials are required, neither need there be lengthy preparation time. It is a dialogue, a method of communication between you and the simplest raw material, the square of paper. From time to time, even the strictest origami purist will give a little leeway and allow himself a small cut or maybe a drawn decoration: indeed it's perhaps a healthy state of affairs for rules to be bent from time to time. In this way, further lessons can often be learnt which will enrich future attempts. But in every case, the end result must be strong enough to allow any taking of liberties. Maybe the most common transgression is the cut: my opinion is that is this almost the worst: apart from the commonly-cited criticism that cutting destroys the purity of the square, my objection to it is a practical one. If a cut is made in error, the work has to be discarded and begun again. If an error is made with a fold, then it is quite possible to unfold the error and remake it correctly.

An individual will inevitably add his own rules to the accepted traditional ones. He will have his own standards and will not wish to cheat himself and compromise. It is the creator's own responsibility to elevate state of the art and move its limits further and further away, and the restrictions which are imposed by himself will enrich his creative efforts. These rules are personal and it could be suggested that is inappropriate to criticize or suggest that he changes them.

My self-imposed rules include:

Economy: It may be difficult to understand this from a book containing a more advanced level of work. But my principle is to make the maximum use of the paper. I dislike unused paper or hidden layers: for example corners "blintzed" or taken to the center of the square in the early stages of the process and not subsequently released and used. Similarly the technique of tidying up a square corner to make a curved shape I find distasteful. The shape of the paper is often better left as it is.

Avoid Classic Geometry and Bases: The classic fish-, bird-, and frog-bases which seem to be such a useful starting point in creative work carry their own problems. Models made from them usually are recognisably from these traditional forms: all rely on the division of the right-angle into equal halves or quarters giving 45 degree or 22.5 degree angles which in themselves produce common shapes: too familiar for my liking. I have preferred the exploration of 60 or 30 degree angles, equilateral triangles, and pentagonal geometries, and finding out how they can relate to the square. This exploration leads to much more unfamiliar shapes, more interesting to my eye at least.

Volume or three-dimensionality: Many origami animals seem to have been run over by a steam roller and I have frequently asked the question "why bother going to the trouble of making four legs, two ears and a pair of horns, when one lies exactly over the other?" It has seemed to me that if a flat animal is made, silhouette style, half that number of details would have been enough. Pressured by my critics and contemporaries in the British Origami Society, I have accepted the principle of the *closed back* when folding animals: this allows a degree of moulding and promotes the folding of animals with a three dimensional structure.

In other non-living subjects, I still feel that a three-dimensional approach is necessary. Philip Shen has said that he dislikes the volume of any origami subject to be achieved by many thicknesses, and a structural and economical style is evident in his own geometric work. I admire Shen's origami and agree with this comment, particularly because of my own preferences for the paper being used in the most effective way.

Let the Paper Speak: I now subscribe to the belief that the folds in any good design are hidden in the paper, with natural reference points or geometries. Creatively I attempt to allow the next creases to form themselves almost as if without my influence. I feel the paper should never be forced to do what it doesn't want to do. The best models have a naturalness or an inevitability which gives them their strength of design.

The rules which the creator will establish for himself will inevitably shift and change; if he uses his eyes, removing blinkers to see the world around him rather than concentrating on existing origami styles, his original creative style will develop naturally and effectively.

Human Figures

For some reason, unlike animals, human figures in origami are less common subjects, and frequently the results are less satisfactory. Is this because we are too familiar with the human form, and less able to accept any liberties which are taken with proportion and detail? Why is there not a really satisfactory figure in origami?

There are certainly many practical difficulties in folding the figure: I have found that arms are frequently too short, and the neck is an awkward aspect to deal with. Kunihiko Kasahara tells me that he considers that a folder would become truly great in his eyes if that folder could achieve a satisfactory female nude...

My interest in the human figure in origami stems back to the influence of Eric Kenneway, who was able somehow to draw with the paper: it's true that his figures were all flat, but they had a style that was truly unique. Much of Kenneway's unpublished work is extremely difficult to reproduce, employing much free-folding, and lack of logical reference points.

I feel that this area represents a true challenge to those seeking to push origami to new boundaries, and I hope that you may be stimulated to carry on the research by my attempts in this chapter.

Fold both diagonals and mark the quarter point as shown. Then fold in half with the colour inside.

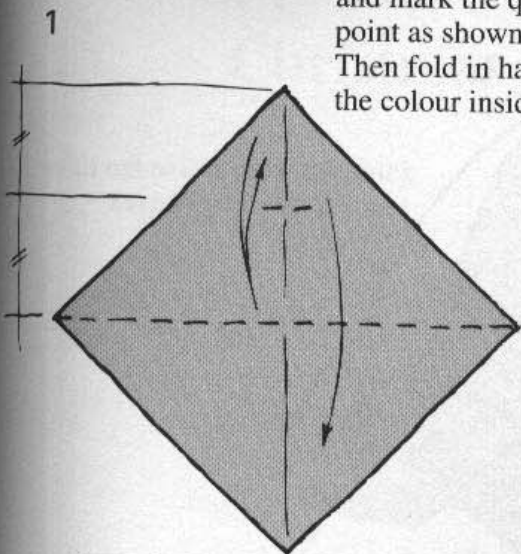

2

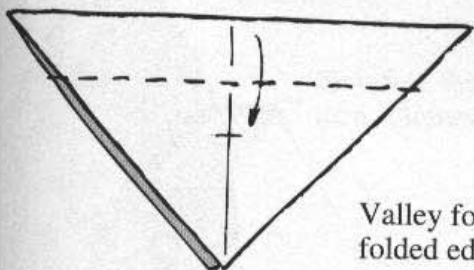

Valley fold the top folded edge to the quarter mark

3

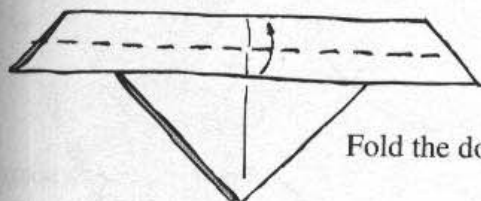

Fold the double layer in half

6

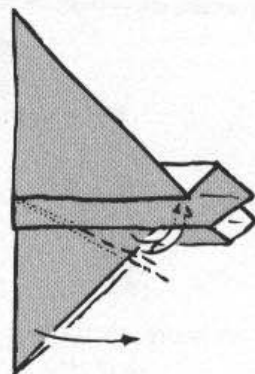

Adjust the position of the chin flap

4

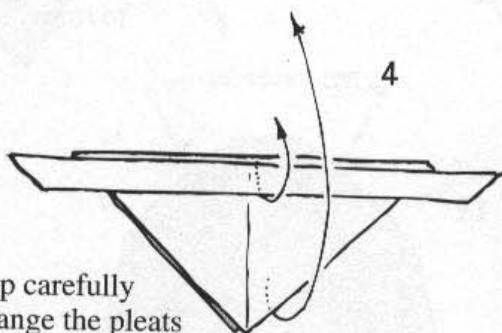

Open up carefully and arrange the pleats as shown in 5

5

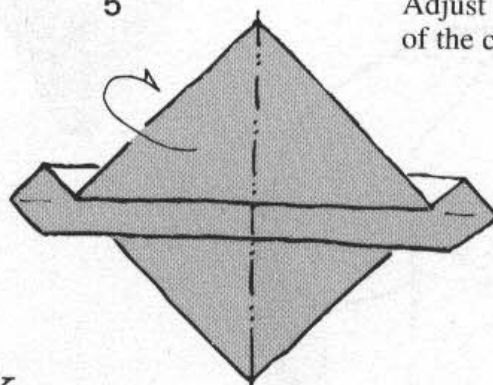

Mask

I was impressed by Yoshihide Momotani's masks: full of character. This is my own attempt making use of similar cross-pleat ideas. Quite a number of expression changes are possible: try using thick paper and handling the material quite clumsily to experiment.

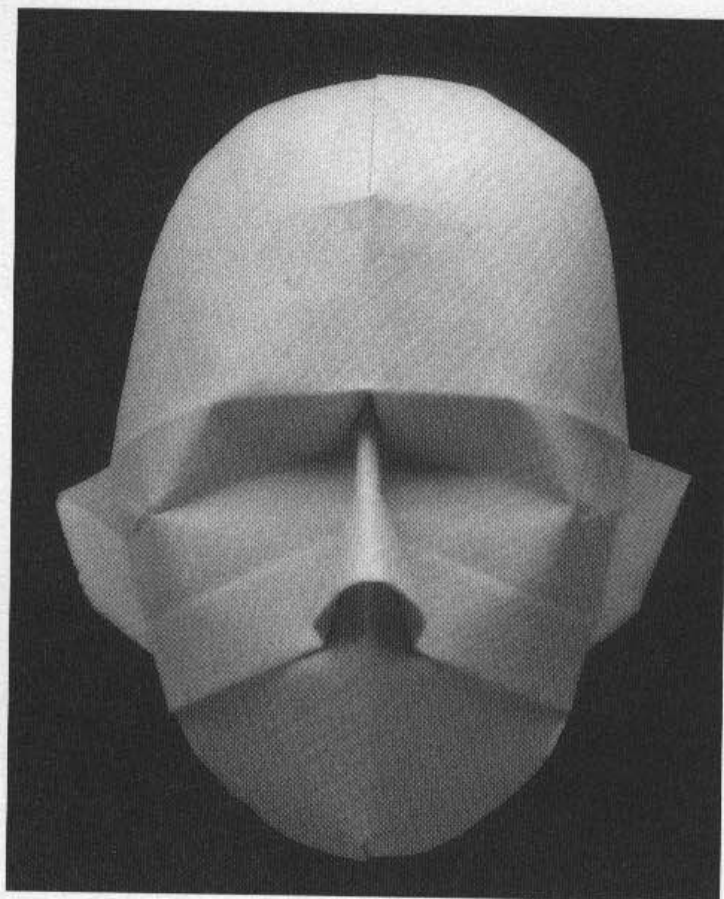

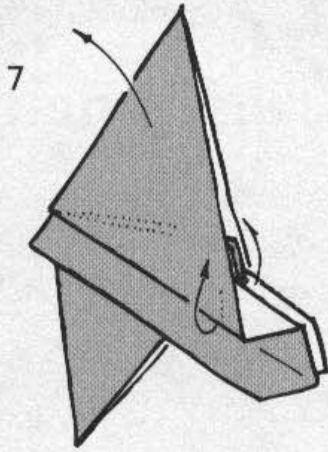

7

Open the upper pleat on both sides following the concealed crease lines: this causes each side to become concave



8

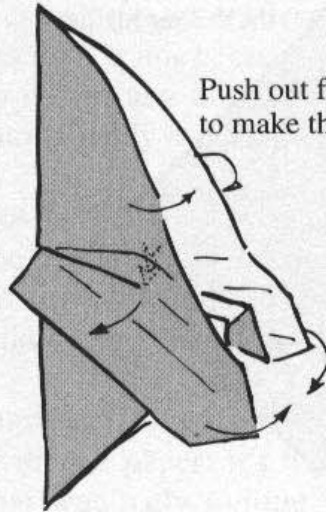

Push out from inside the brow to make the face convex

9

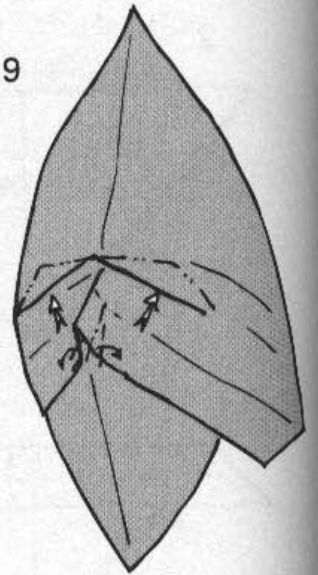

Push in the eye sockets and spread the nose to form a 3D shape

10

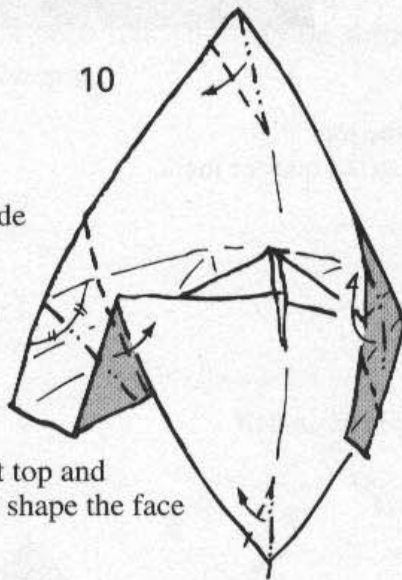

Pleat the ears inside

2 pleats at top and bottom to shape the face

11

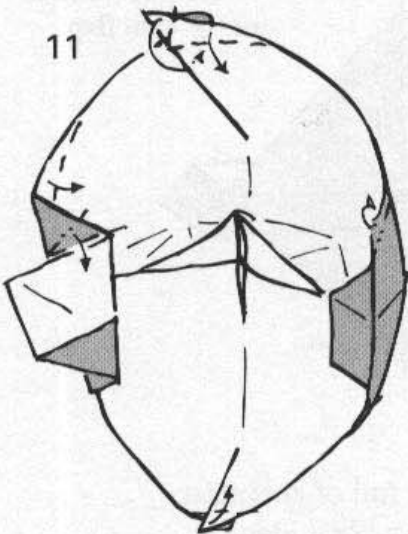

Lock the pleats as shown

12

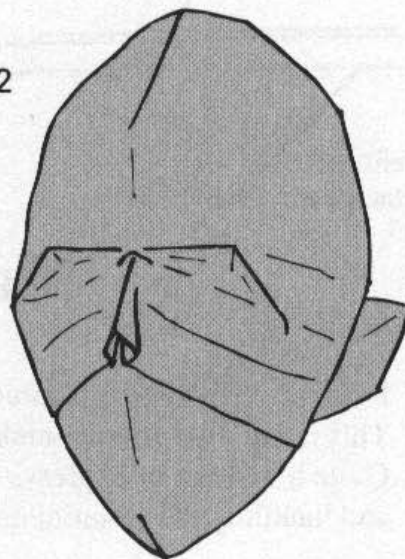

Christmas Tree Fairy

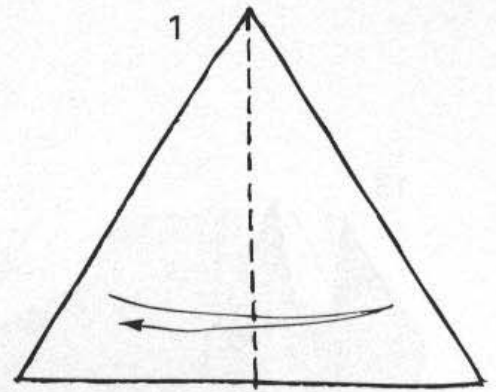

Use an equilateral triangle, side length 20 inches (48 cm). Textured gold foil works well.

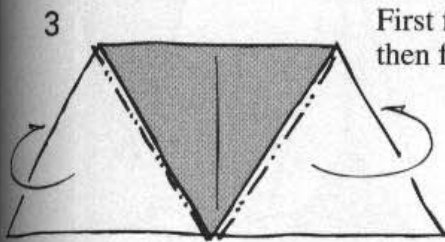
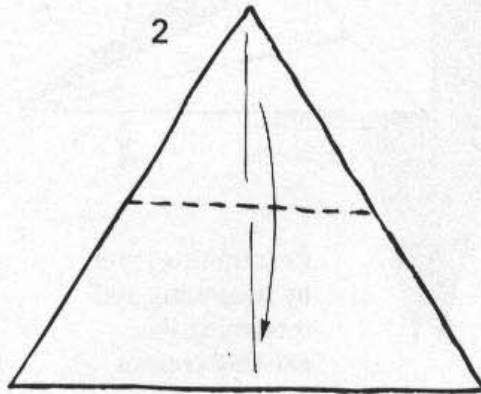

First fold the left hand corner behind, then followed by the right hand corner

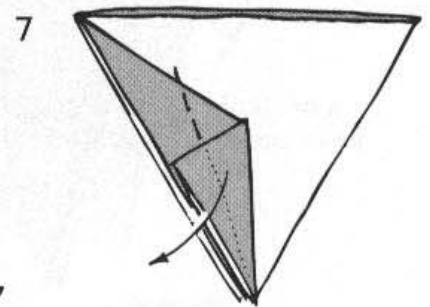
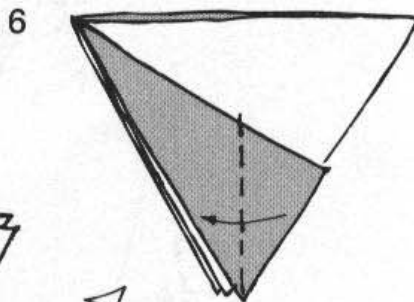
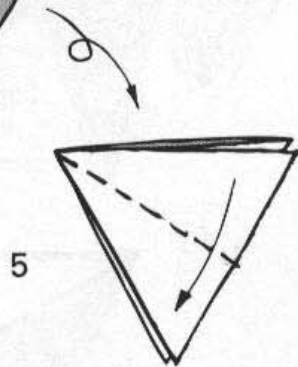
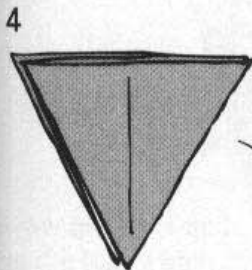

Adjust the position of this flap

Having spent a lot of time making this decoration for the top of a Christmas tree, I realised with horror that I had forgotten to give the Fairy any wings! I did attempt to make the figure with the crown and wand from a single sheet, but the results were ghastly. I prefer the 3 sheet ensemble which doesn't compromise the individual elements.

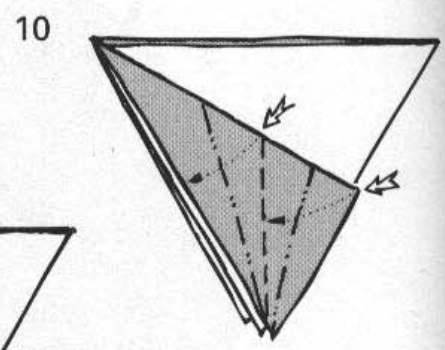
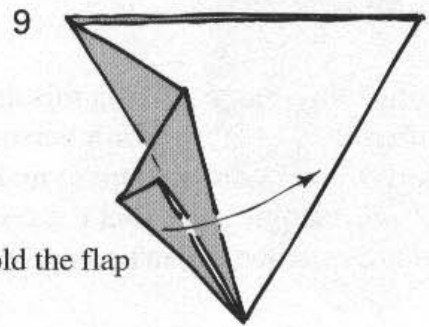
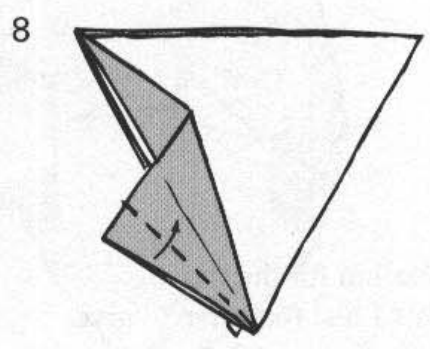
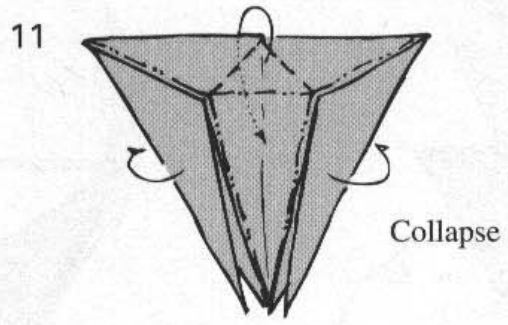
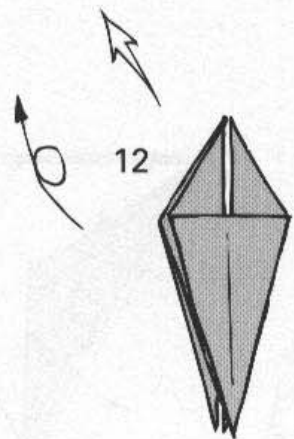
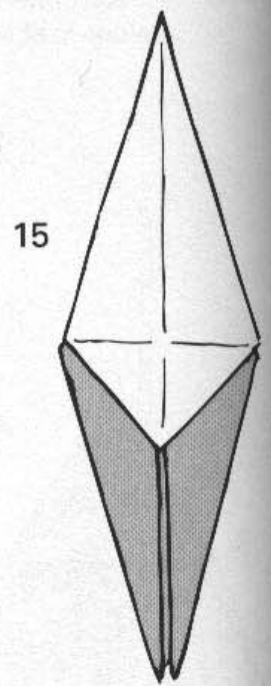
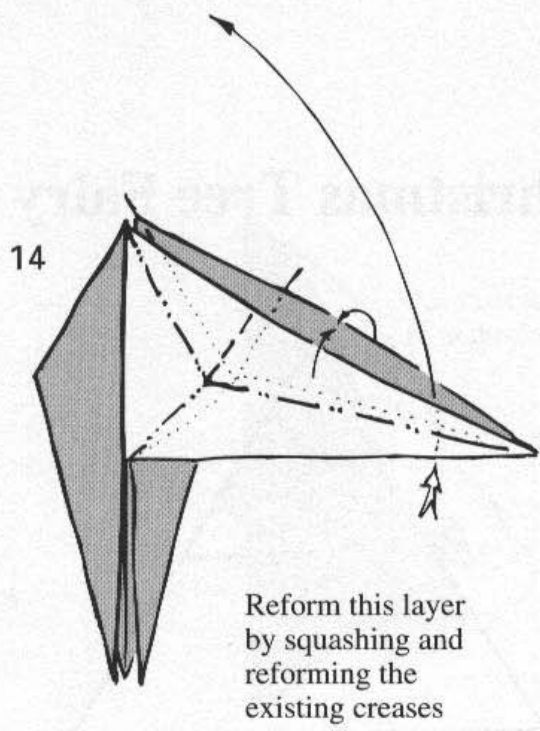
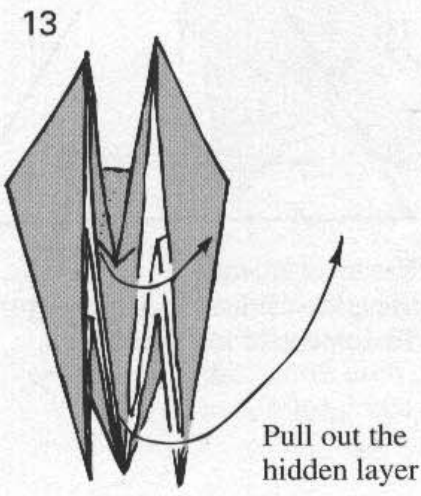

Reverse fold twice to form one leg then repeat with the right hand side

16

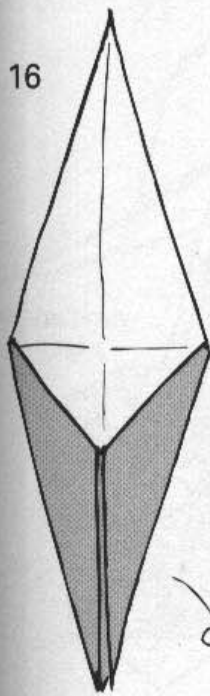

17

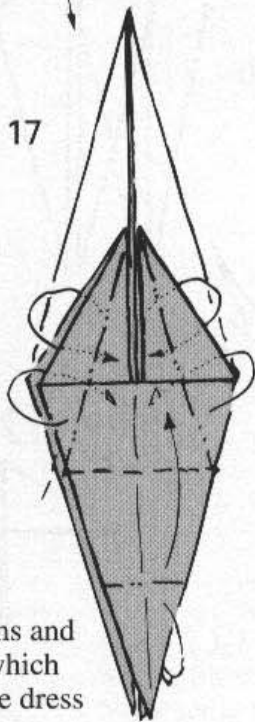

Narrow the arms and pleat the flap which will become the dress

Open one layer carefully at left and right

21

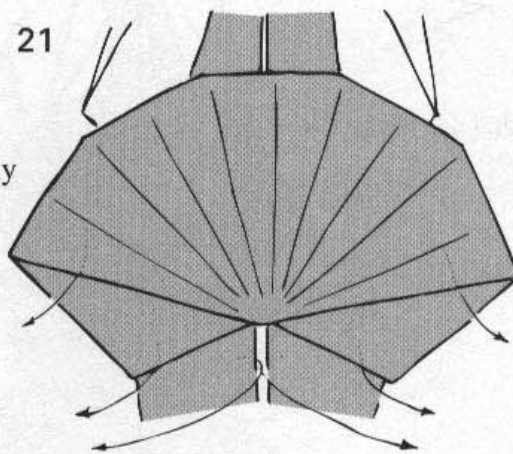

20

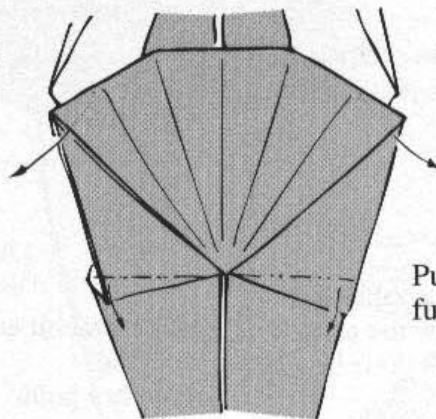

Pull out a futher layer

18

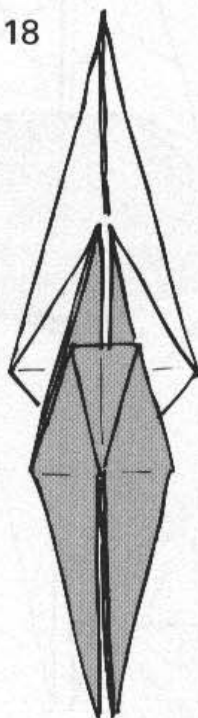

19

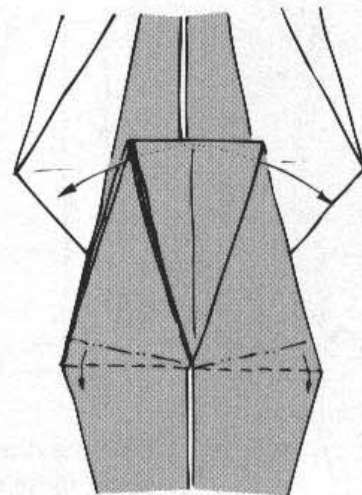

Pull out layers from within the dress flap

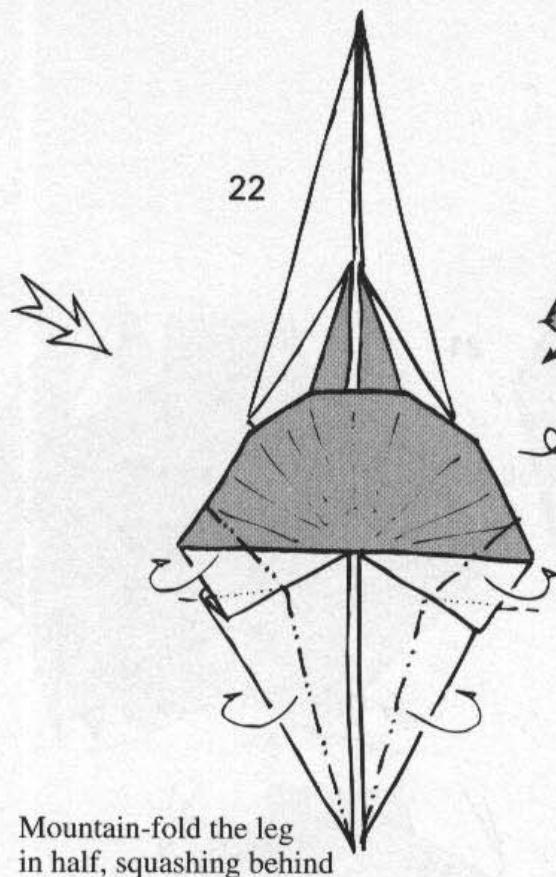

22

Mountain-fold the leg in half, squashing behind

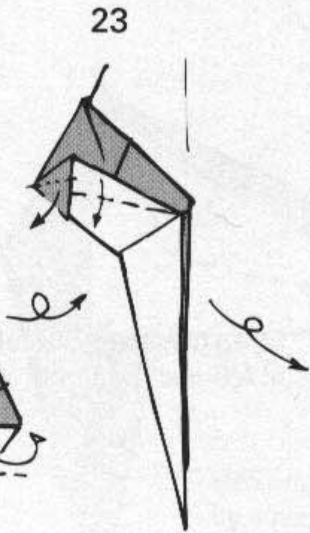

23

Adjust this layer

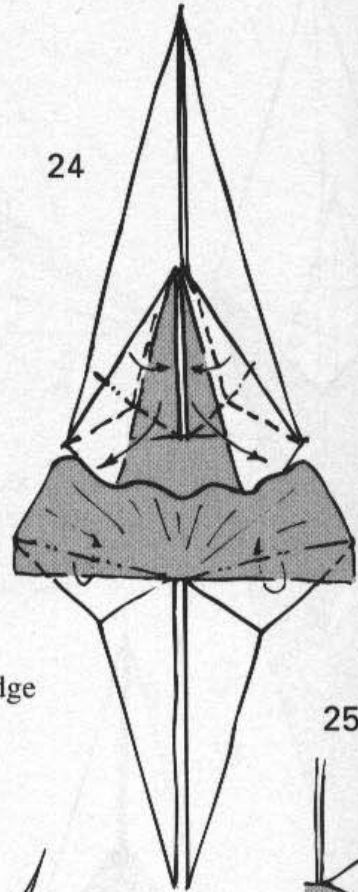

24

Tuck in the lower edge of the dress, and rabbit ear both arms

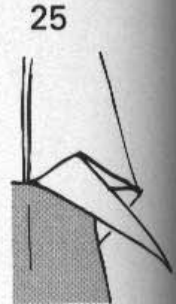

25

Reform the rabbit ear and narrow the neck: these folds don't lie flat

Make a rabbit ear: Note the reference point

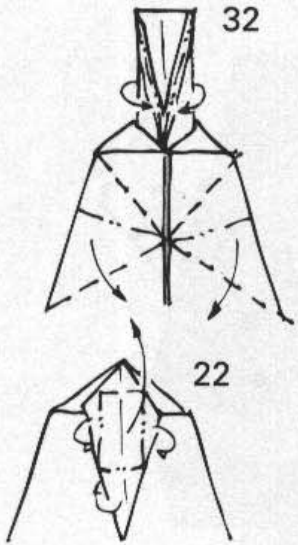

32

22

Formation of the neck

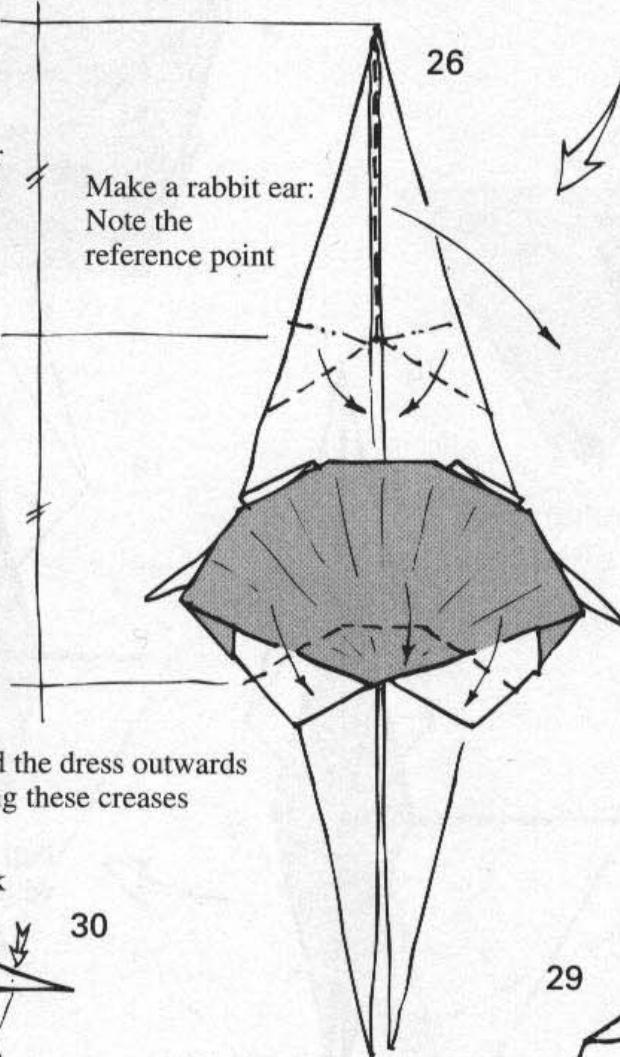

26

Fold the dress outwards along these creases

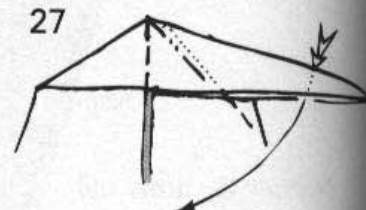

27

These folds make the face

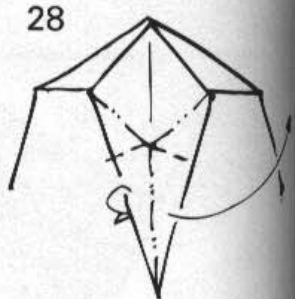

28



30

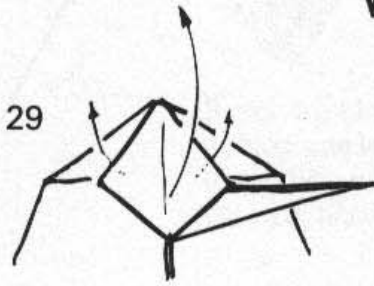

29

33

Curve the face

Tuck the neck behind the shoulders

Shape the body and the waist

Curve the thighs

34

Valley fold the hair

Form the hands

A small pleat shapes the legs and knees

Repeat the last 2 steps on all corners

Crown

1

Use a 2 1/2 inch (6 cm) square for the finished crown, but practise with a larger size

2

Form a waterbomb base

3

Reverse fold 4 times

4

Open out back to step 2

5

a) fold out this corner

b) Narrow the point

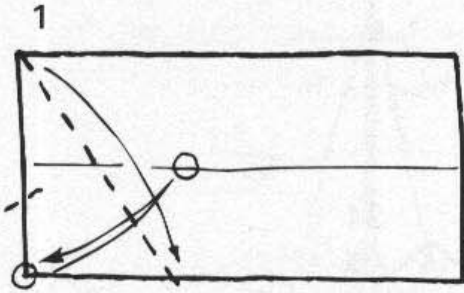

Use a 2x1 rectangle,
2 1/2x5 inches (6x12 cm)
for the finished model, but
practise with a larger size

Precrease a 60 degree valley fold
then mark 1/3rd as shown

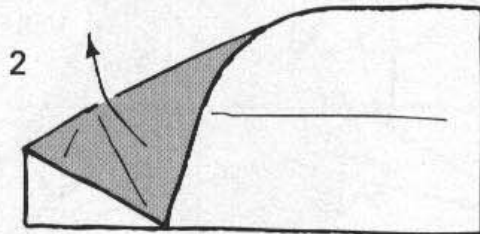

Wand

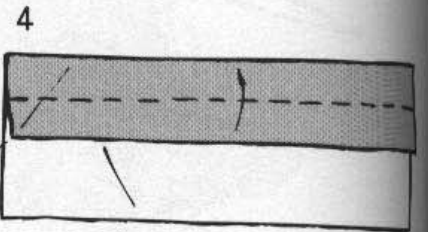
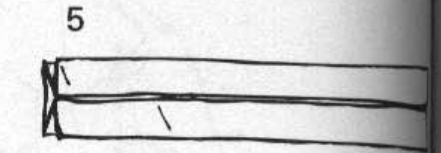

Divide into 1/3rds, then 1/6ths

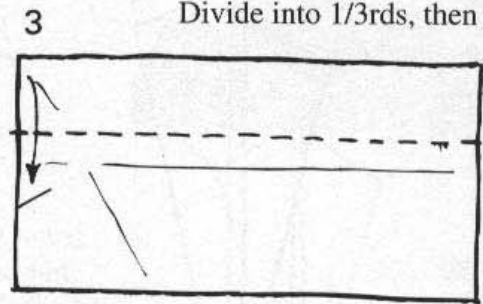

Crown (continued)

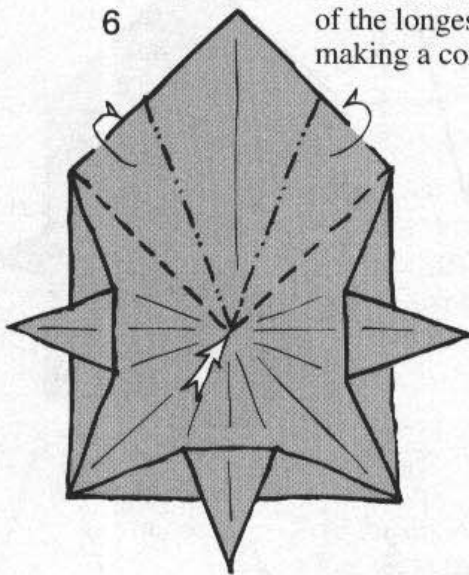

Pleat either side
of the longest corner,
making a concave shape

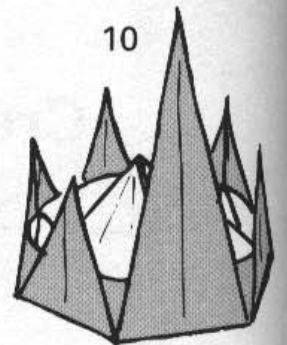

Form a circular band
connecting each point
of the crown

Form a hexagon of
mountain folds in the
centre, peeling the points
downwards

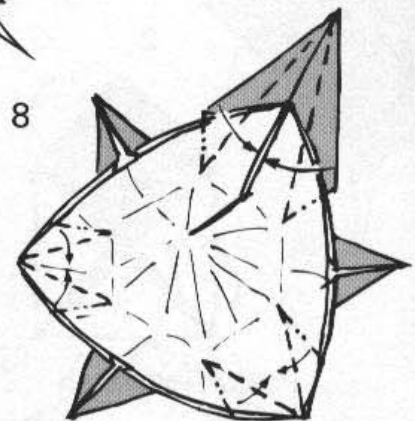
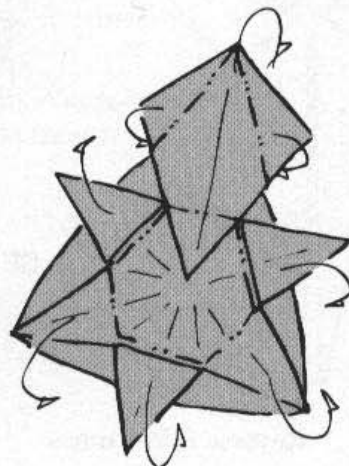

Form 2 short points
and 1 long one with
6 pleats

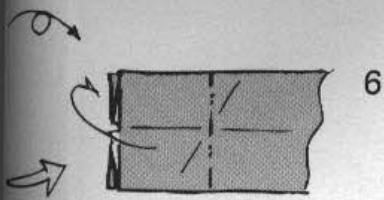

Fold in half and squash behind

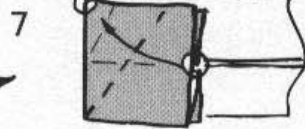
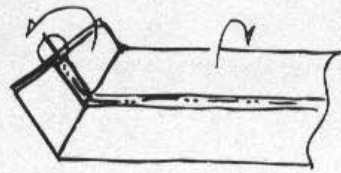

Fold 60 degrees as shown

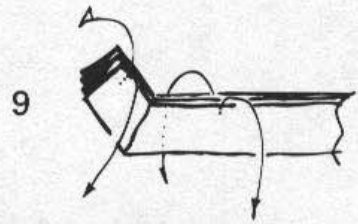

Open out completely

10

Reform with multiple crimps

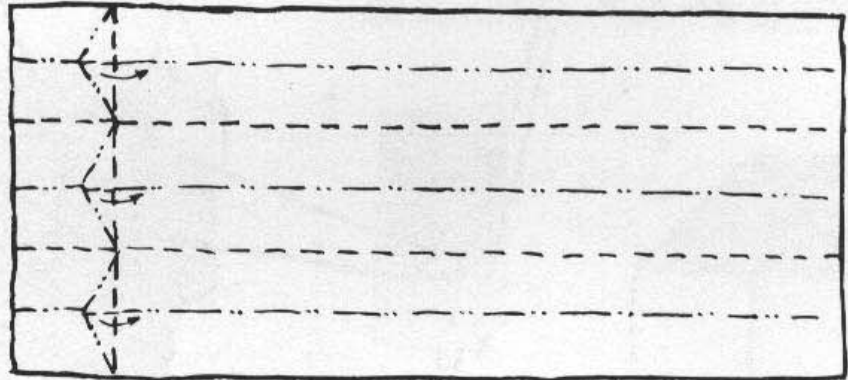

11

Reverse fold twice in the centre and fold corners down at the front and back

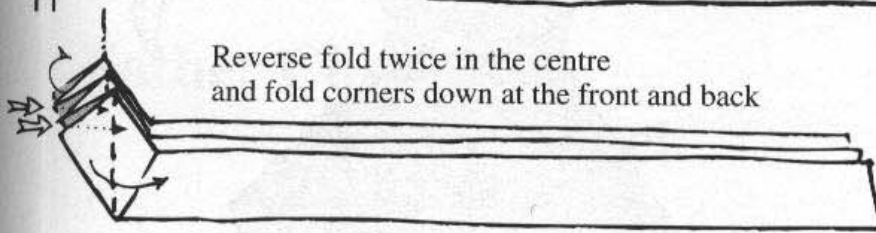

12

Open the uppermost triangle

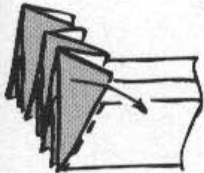

Pull out the remaining corner to create the final point of the star

13

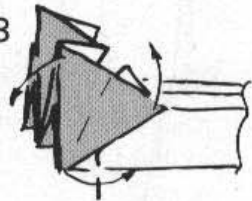

Rotate this triangle

14

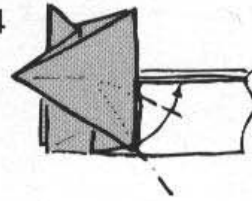

15

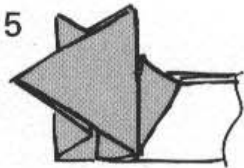

18

Repeat the last move to narrow the stem again

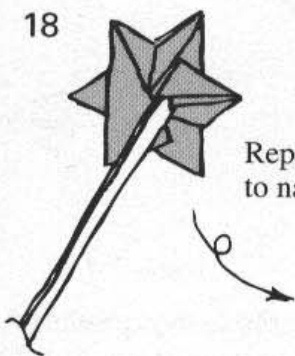

17

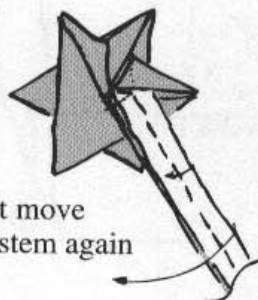

16

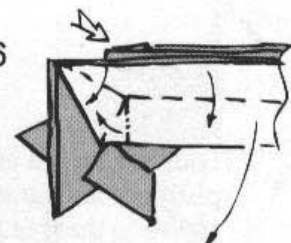

Rabbit ear to narrow the stem and squash the corner behind

19

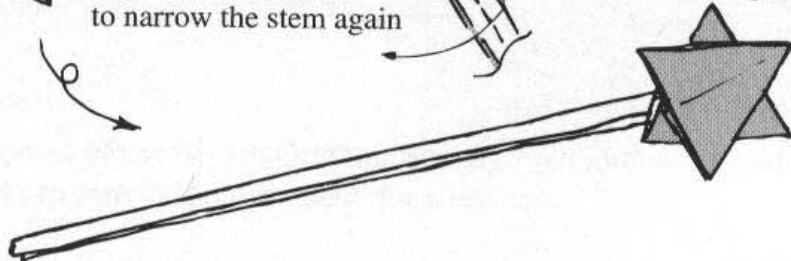

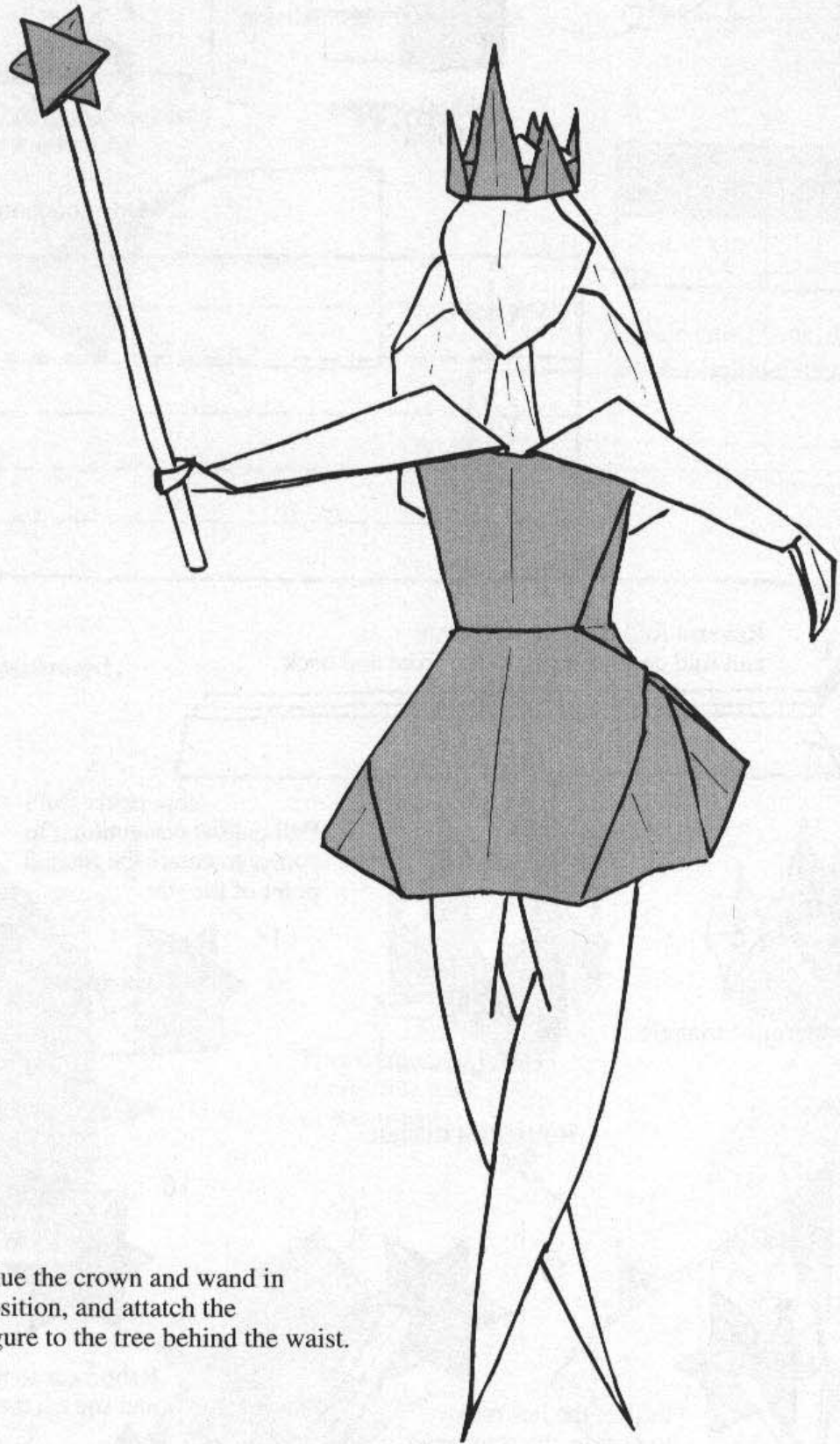

Glue the crown and wand in position, and attach the figure to the tree behind the waist.

Use a 2x1 rectangle
of red and white paper

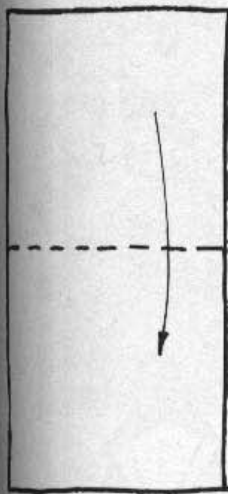

1

Fold in half twice

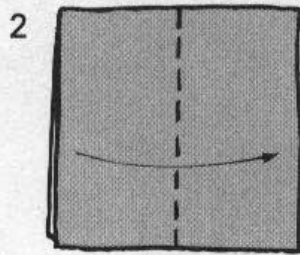

2

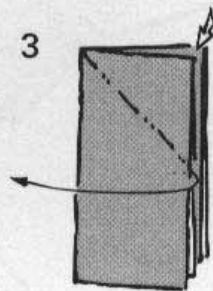

3

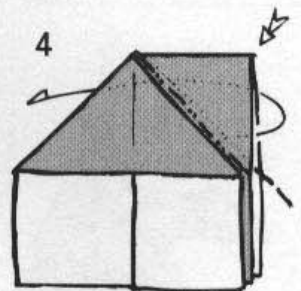

4

Open and squash twice

Father Christmas with his Sack



6

Rotate front and back

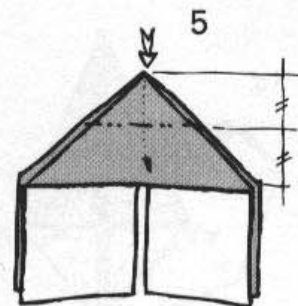

5

Sink the point

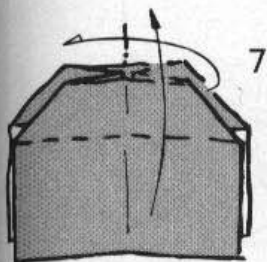

7

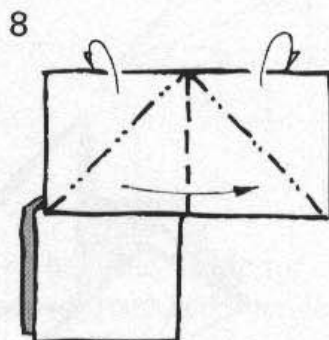

8

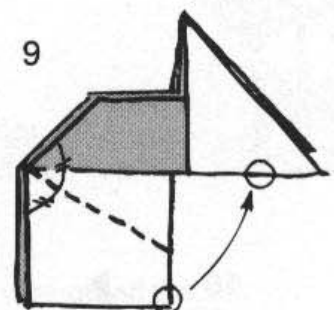

9

Valley fold, noting
the location point

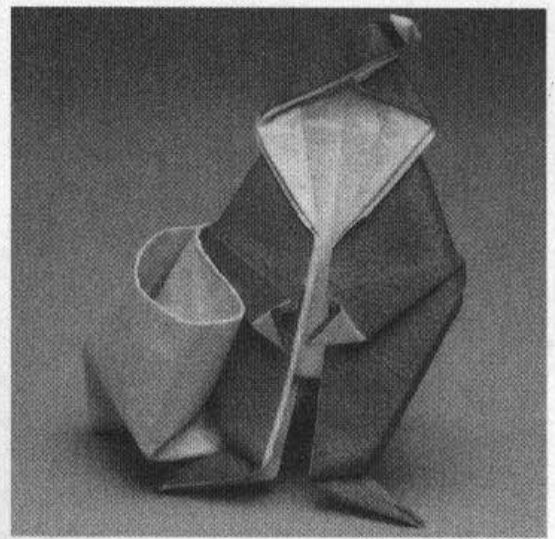

Another product of the British Origami Society "Whodunnit" column.
The idea was to provide an open sack for a present.

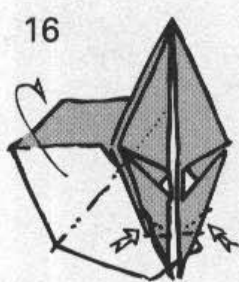

16
Fold the sack in half and form the feet

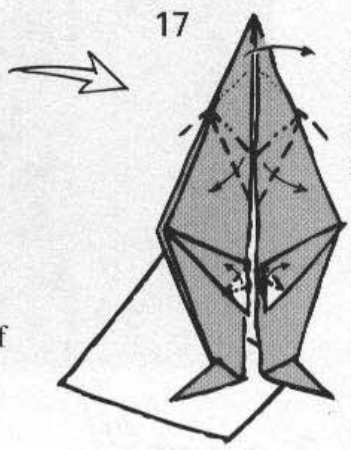

17
Pleat the hands and open the face, simultaneously forming the hat

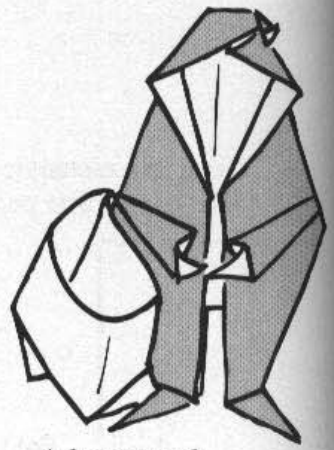

A larger sack can be formed by omitting step 10

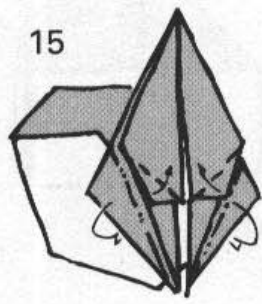

15

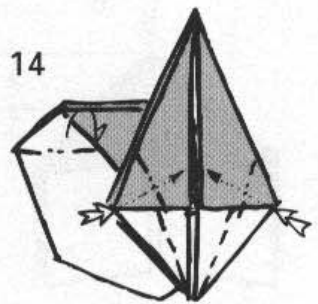

14

Reverse fold twice, and mountain fold to lock the sack

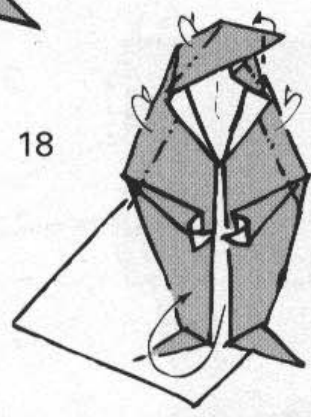

18

Shape the hat and shoulders with mountain folds, and bring the sack to the front

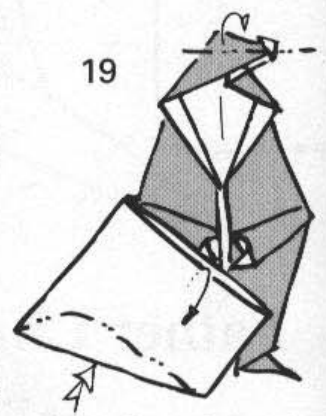

19

Open the sack, and mountain fold the hat

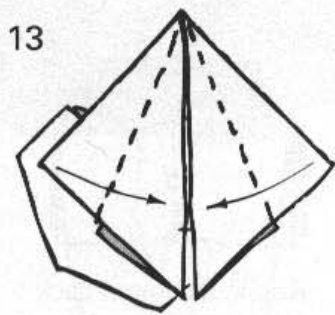

13

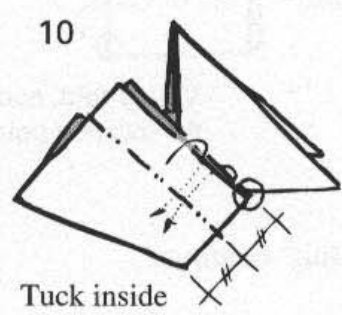

10

Tuck inside

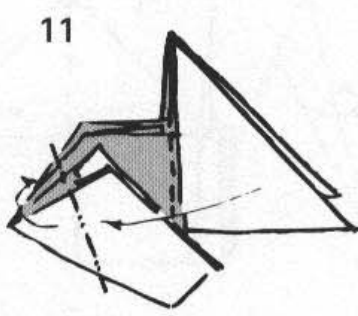

11

Mountain fold to lock the sack (the lower edges of the sack are equal)

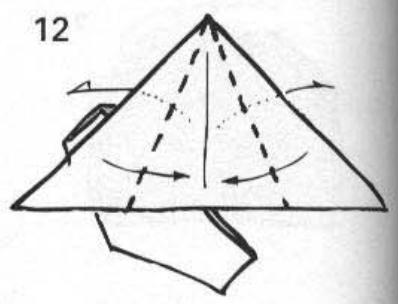

12

Valley fold allowing corners to come from behind

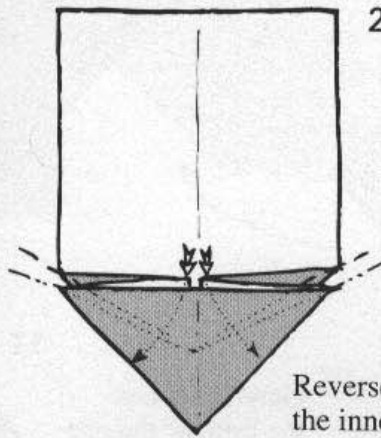
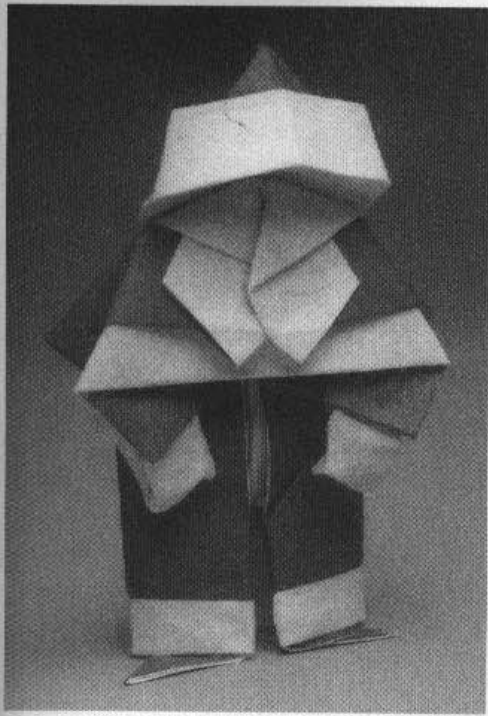

Reverse fold the inner corners

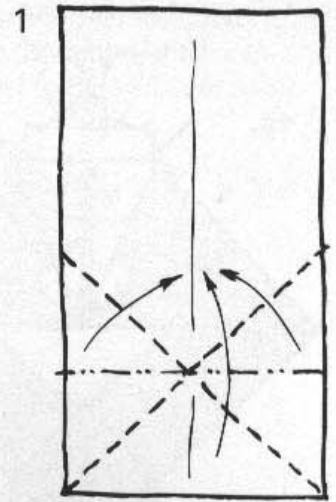

Start with a 2x1 rectangle, red and white, minimum size 12x6 inches (30x15 cm)

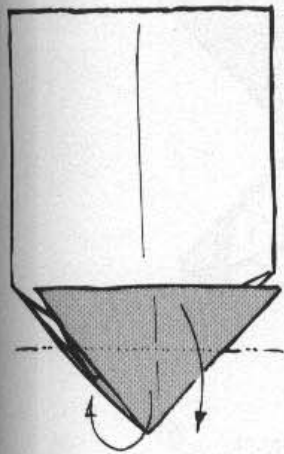

Mountain fold the corner behind and let the triangle swing downwards

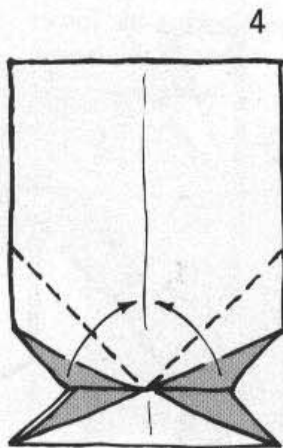

Father Christmas

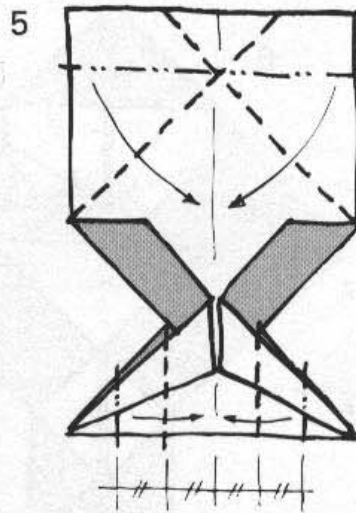

Pleat the lower white triangle

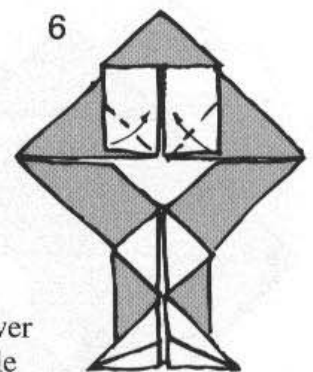

I made a Father Christmas figure for an early version of the sleigh, and reindeer group and intended to make drawings of this for this book. However I realised that the original figure was far too slim and I therefore had to redesign the figure before starting the drawings. The only common ground with original is the initial few steps and the head.

Make a rabbit ear
on the head and
shoulder area

12

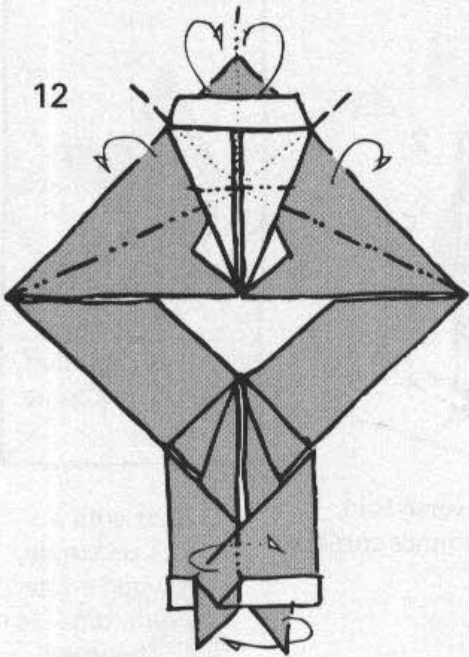

14

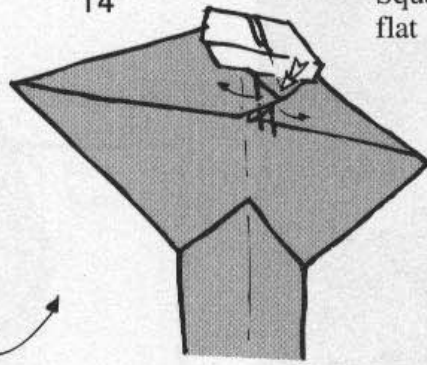

Squash the head
flat

15

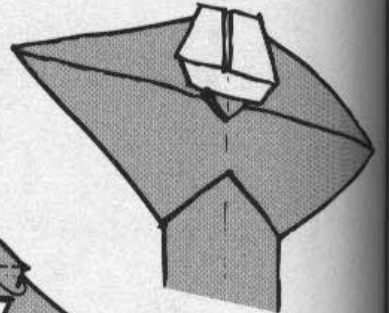

Outside reverse
the brim of the cap

11

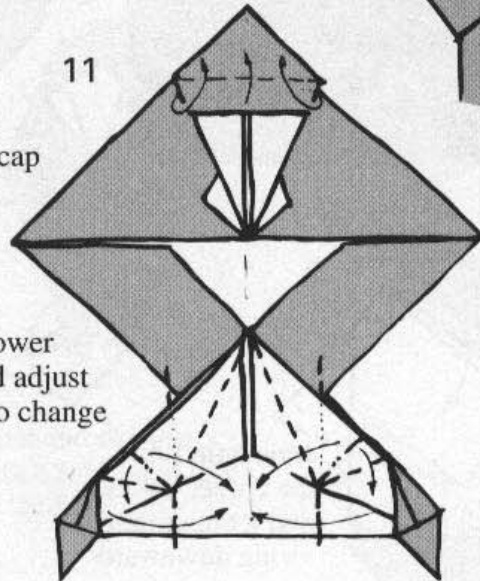

Close the lower
triangle and adjust
the layers to change
the colour

Tuck each foot
behind

13

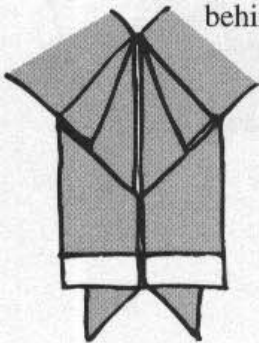

Narrow the face
allowing the lower
edges of the beard
to swing out

8

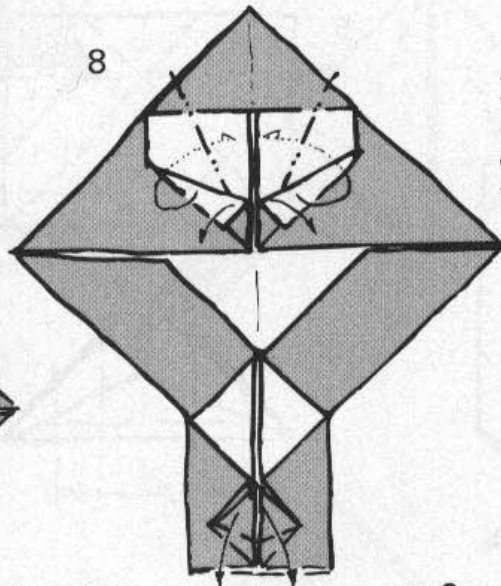

7

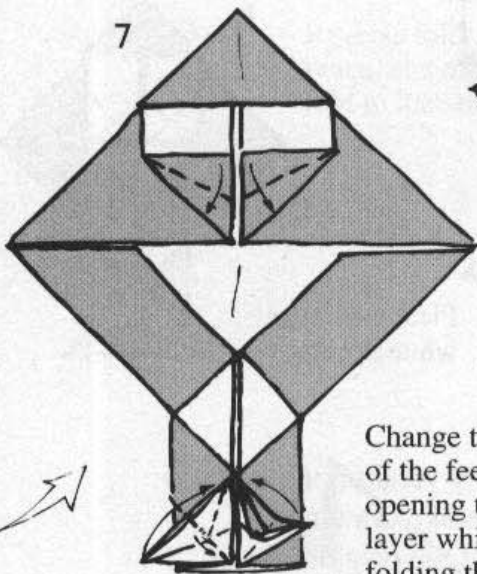

Change the colour
of the feet by
opening the single
layer while valley
folding the point upwards

9

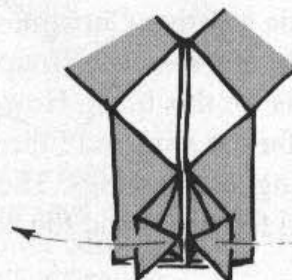

Open the lower
edge completely

10

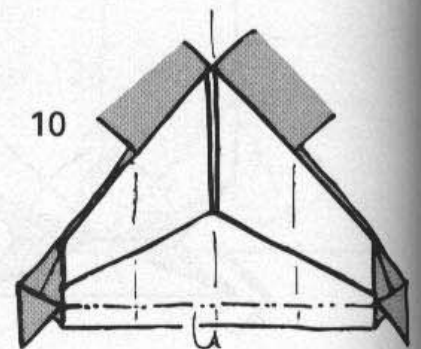

Mountain fold
the lower white edge

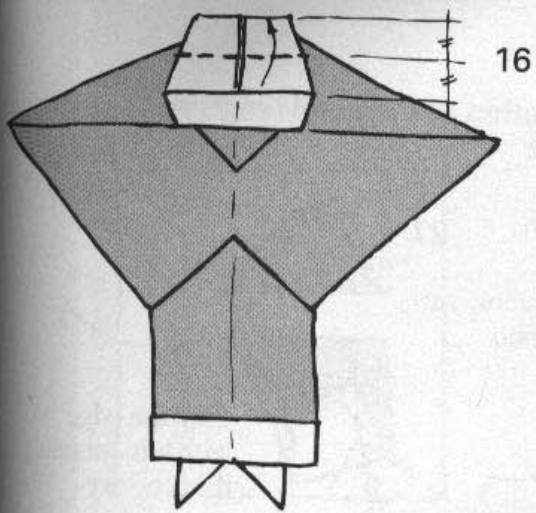

Valley fold the brim of the cap to the edge

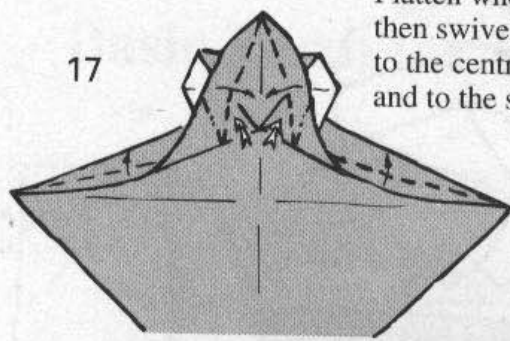

Flatten where indicated then swivel the edges to the centre of the cap and to the shoulder line

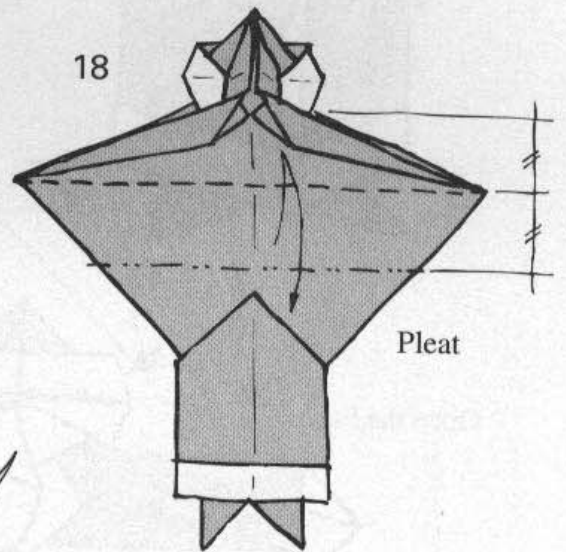

Pleat

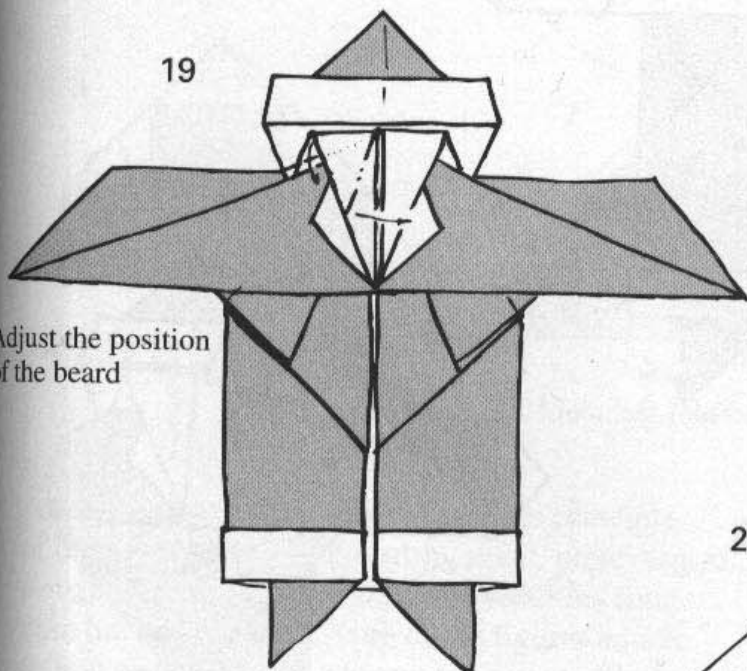

Adjust the position of the beard

Precrease the hand, then open

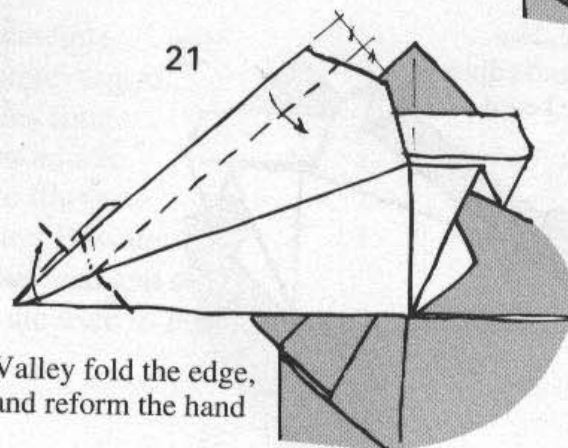
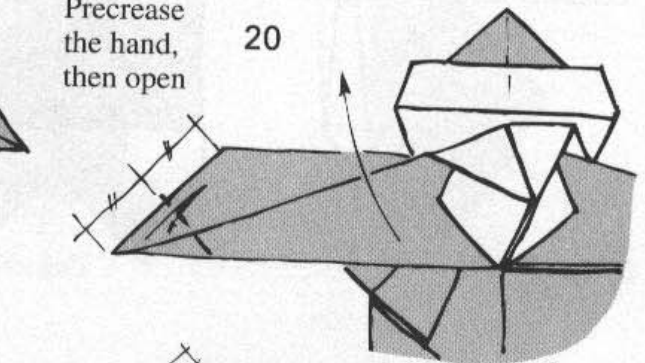

Valley fold the edge, and reform the hand

Formation of the hands (optional)

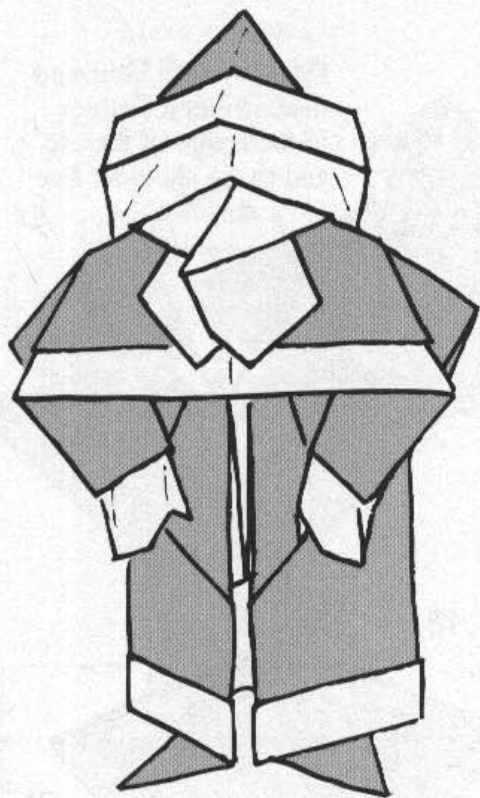

Make a small rabbit-ear to form the thumb

27

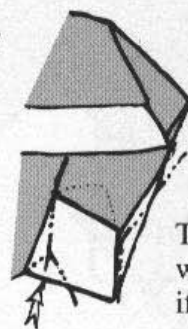

Tidy the edge with a mountain fold if necessary

25

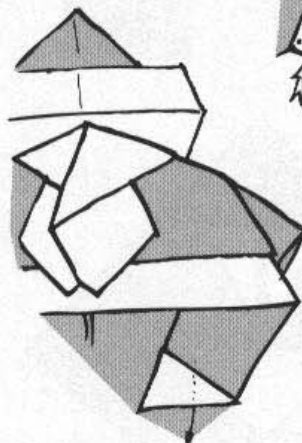

Pull out corner from behind.

26

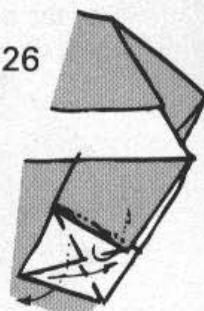

Valley fold and tuck a layer under the cuff

Open the hat

24

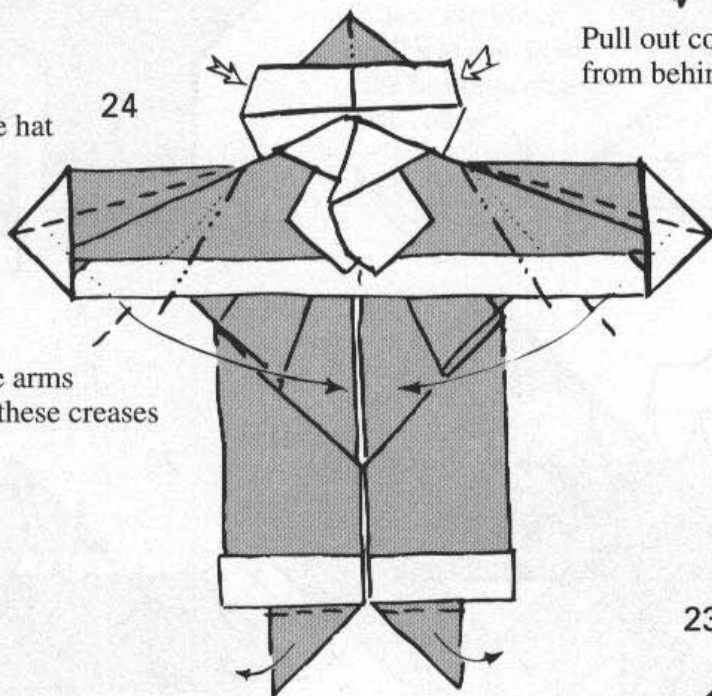

Reverse fold the arms carefully along these creases

Change the colour of the hand and adjust the tip of the beard

22

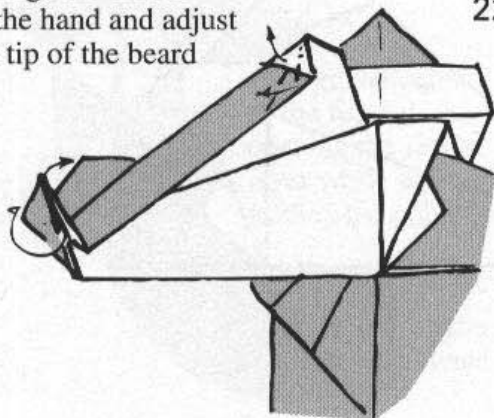

23

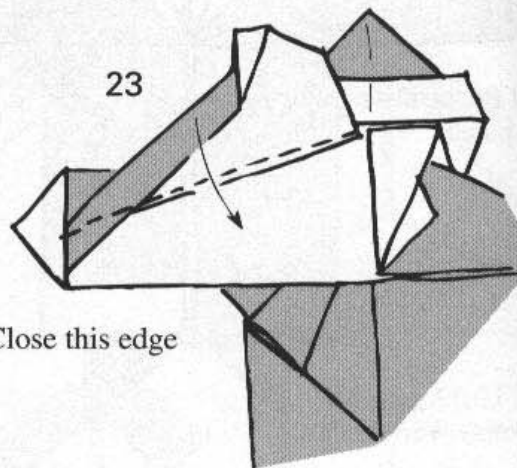

Close this edge

Basic Form for Figures

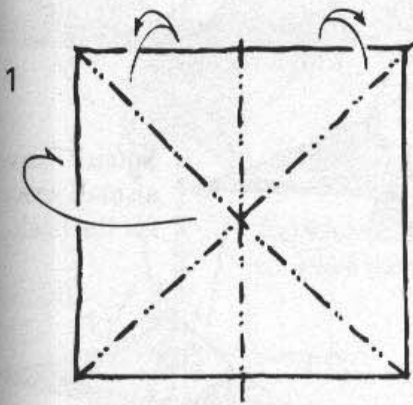

1
Precrease mountain fold diagonals from the white side then fold in half

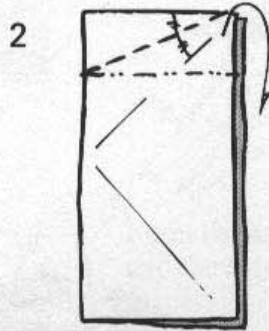

2
Pleat

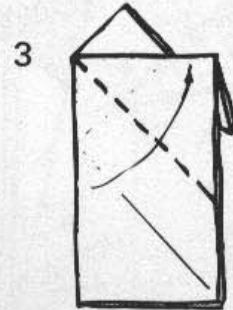

3
Valley fold

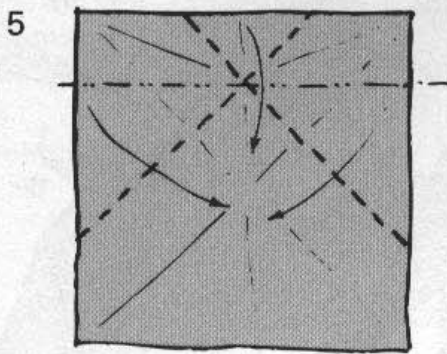

5
Reform according to these creases

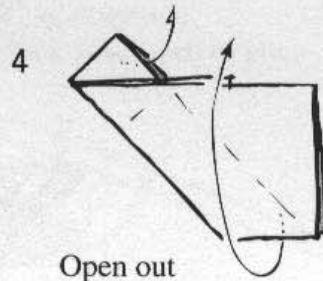

4
Open out

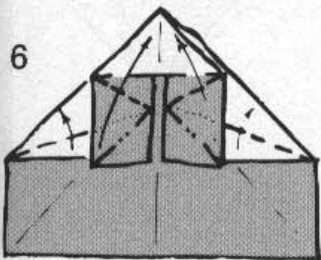

6
Adjust the position of the arms

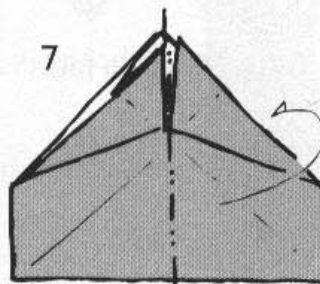

7
Mountain fold in half

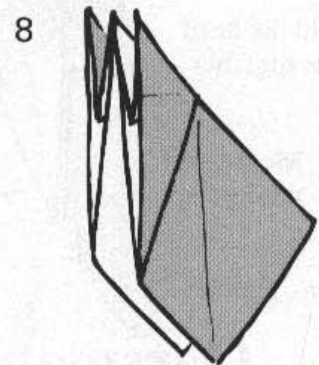

8

Although I have generally resisted the principle of the base as a creative starting point, preferring to design directly from the starting sheet, this figure base has been useful. Many of the figures which follow were designed for commissions to illustrate the calendar for British paper manufacturer Bowater-Scott in 1984 and 1985. The base uses the head and ears from the corgi and lamb, but these flaps are used to make limbs for the various figures.

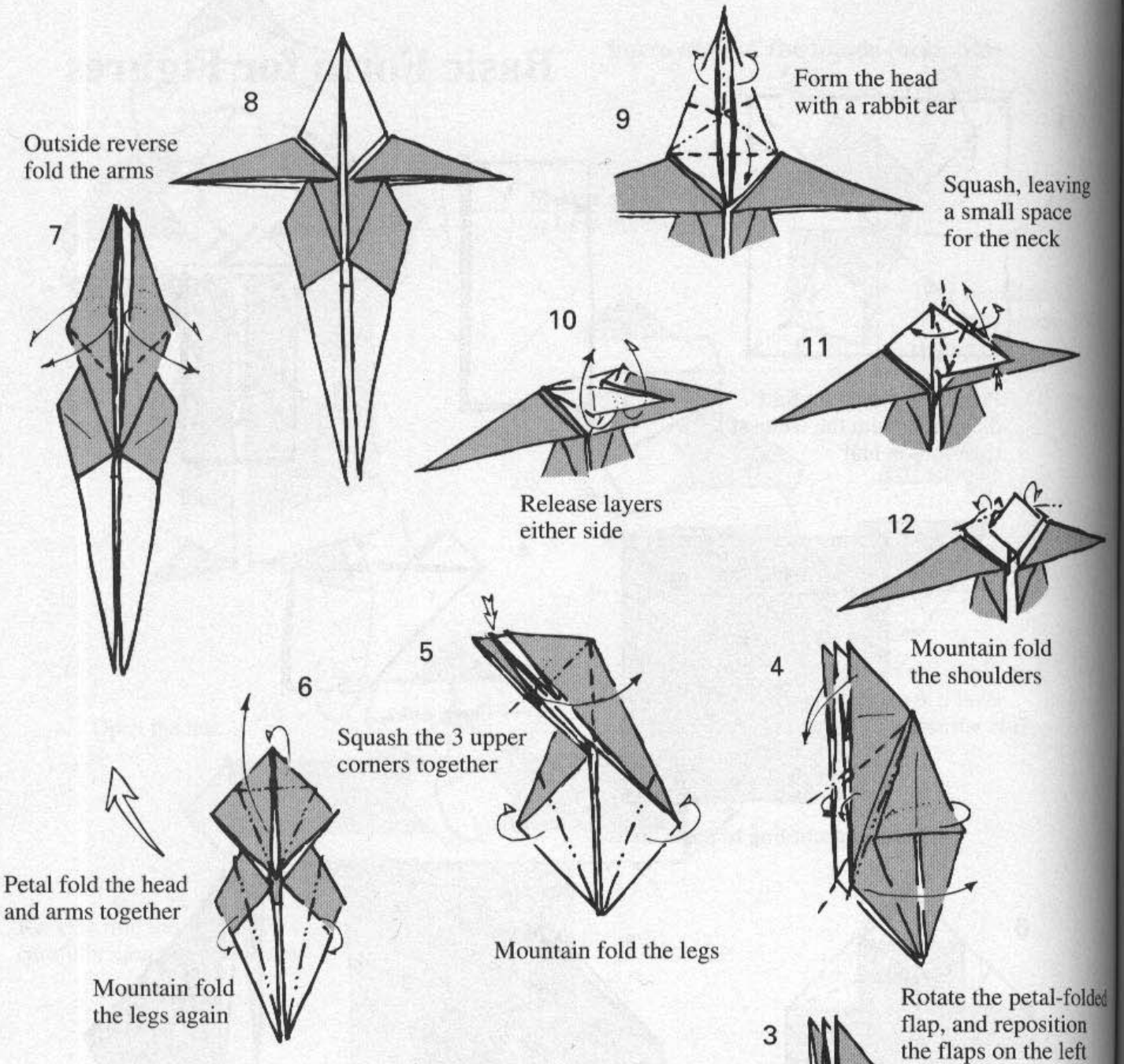

Oarsman

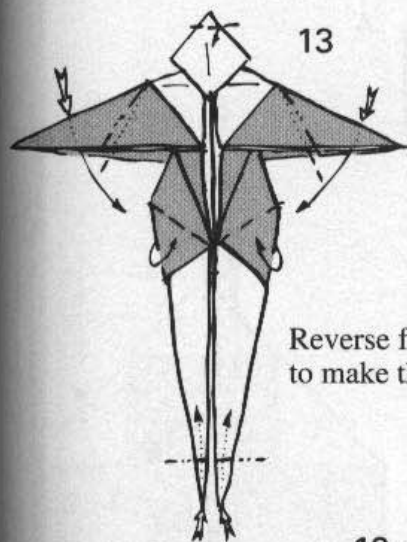

Reverse fold the arms to make them white



Pleat the ears

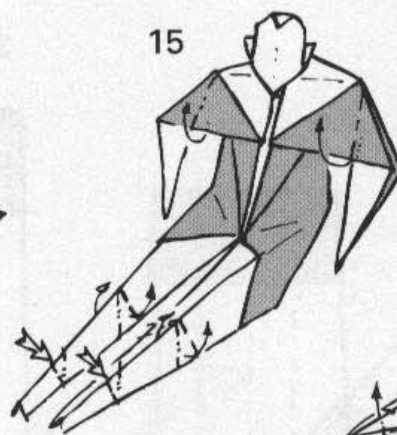

Form the knees and the feet

Lift the arms

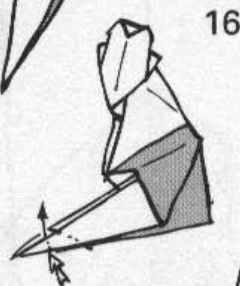

16



18

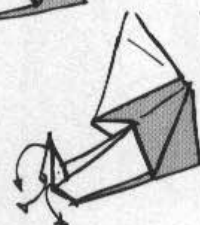

17

Formation of the hands: open the layers from within the reverse fold

Place the oar in the rowlock and the hands, fastening with dabs of glue

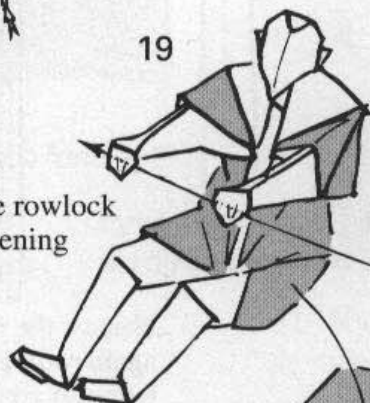

19

Position the oarsman on his seat attaching only the leg nearest to the rowlock with a dab of glue.

See p.200 for instructions for the oar.

Seat and Rowlock

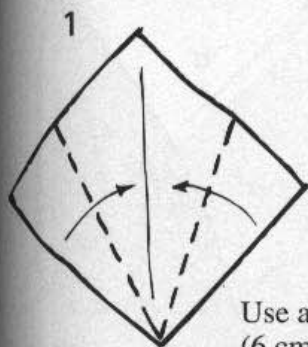

Use a 2 1/2 inch (6 cm) square

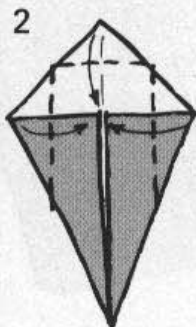

2

Precrease these diagonals at 45 degrees to the centre line

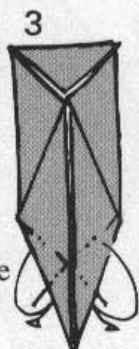

3



4

Sink this point

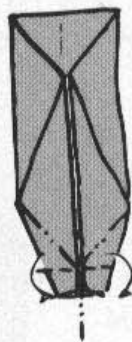

5

Form a rabbit ear

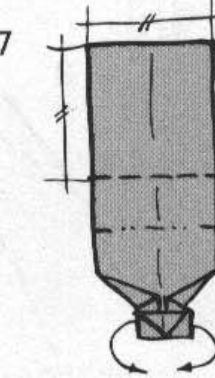

7

Pleat the seat to fit in the boat and curve the tips of the rowlock

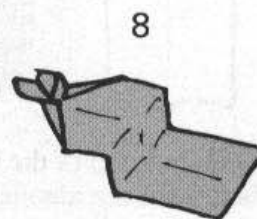

8

Open and flatten

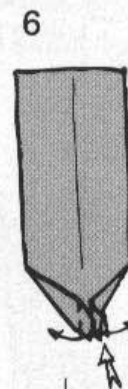

6

-folded
tion
left

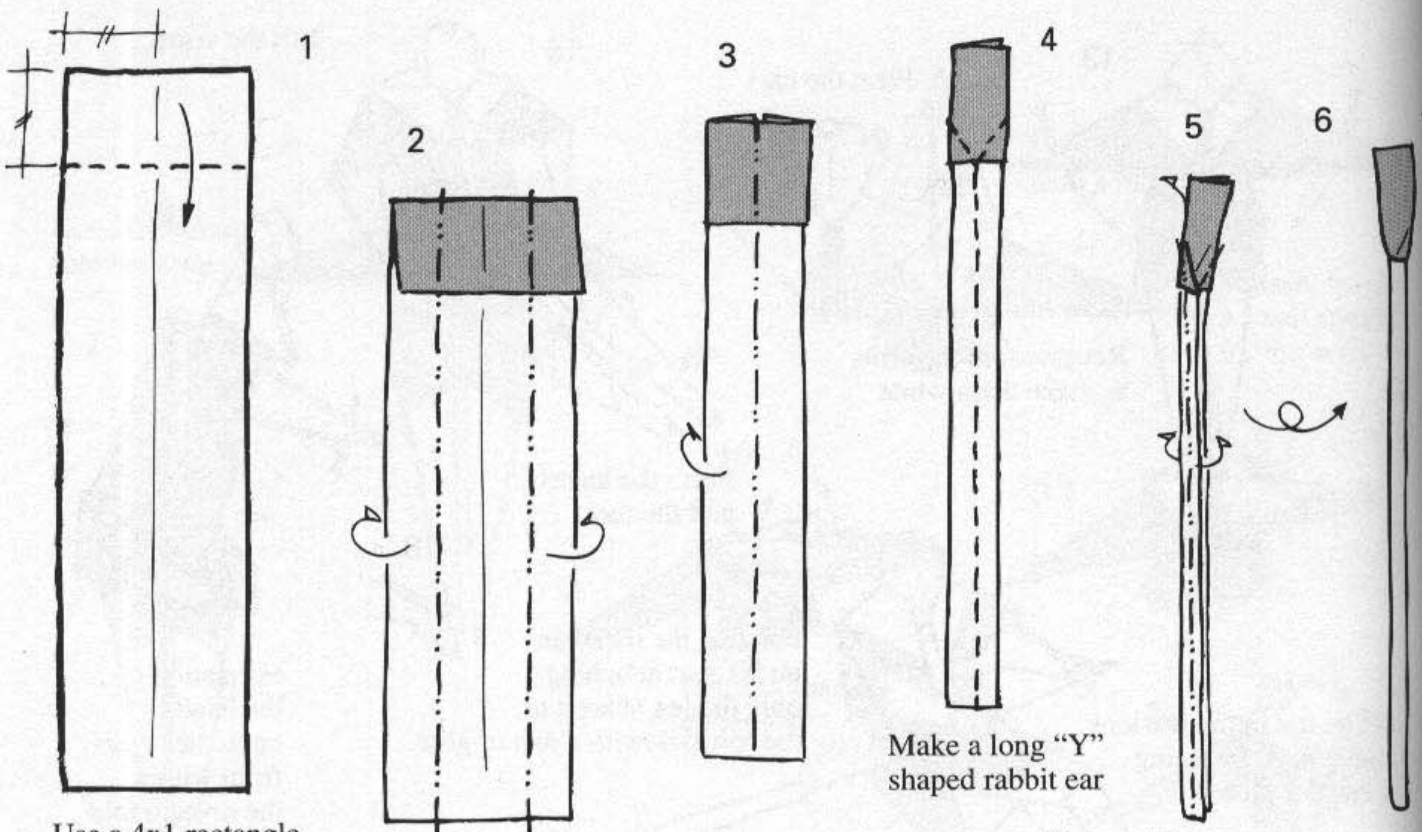

Use a 4x1 rectangle
7 x 1 3/4 inches
(18 cm x 4 1/2 cm)

Make a long "Y"
shaped rabbit ear

Narrow the oar
again rolling it
between your
fingers to tighten
the shaft

Shape the blade
with a gentle
curve

Oar

Use a long rectangle
30 x 3 inches
(75 cm x 7 1/2 cm) for
an "eight"

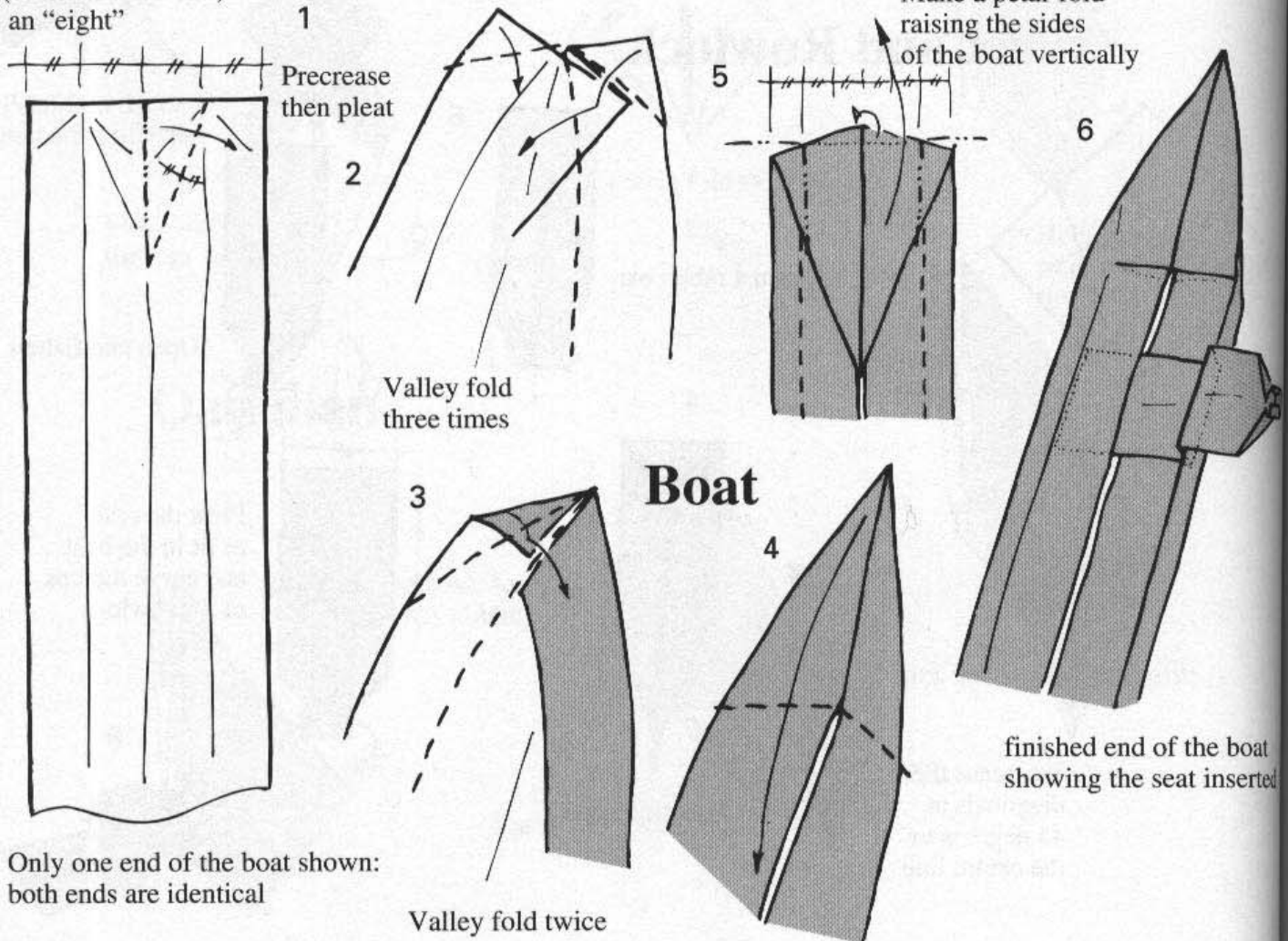

1 Precrease
then pleat

2 Valley fold
three times

3 Valley fold twice

5 Make a petal-fold
raising the sides
of the boat vertically

Boat

6 finished end of the boat
showing the seat inserted

Only one end of the boat shown:
both ends are identical

Cox

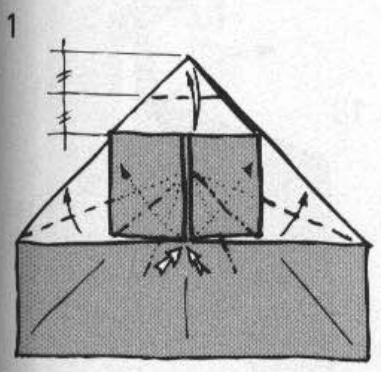

1
Start with step 6 of the figure basic form (p.197)

Reverse fold left and right and precrease the top point

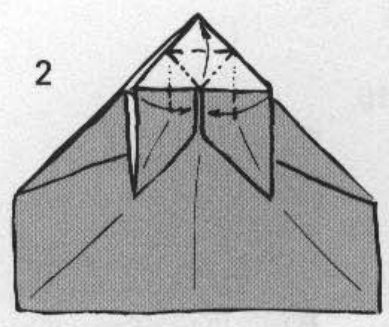

2
Make an incomplete petal fold

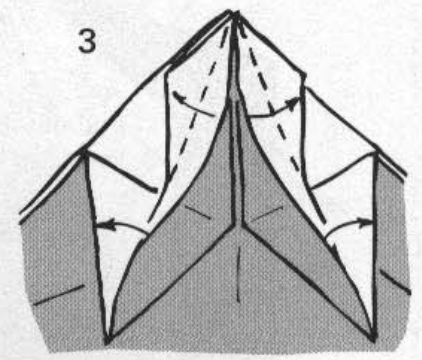

3
Fold the raw edges to the outside edges

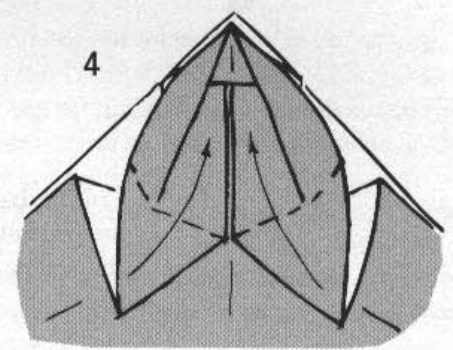

4
Reposition the arm flaps

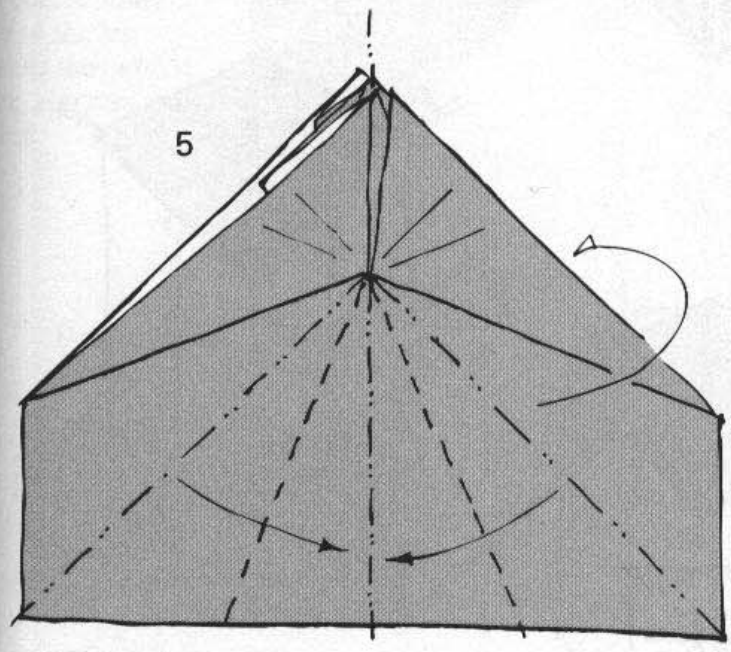

5
Fold in half, and pleat at the lower centre

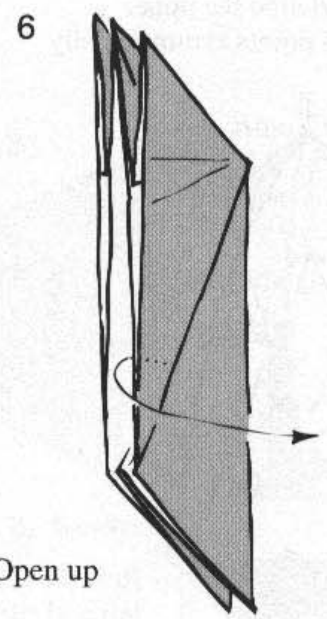

6
Open up

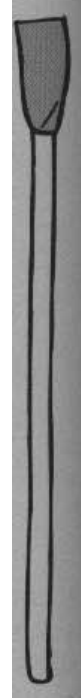

the blade gentle



coat
erted

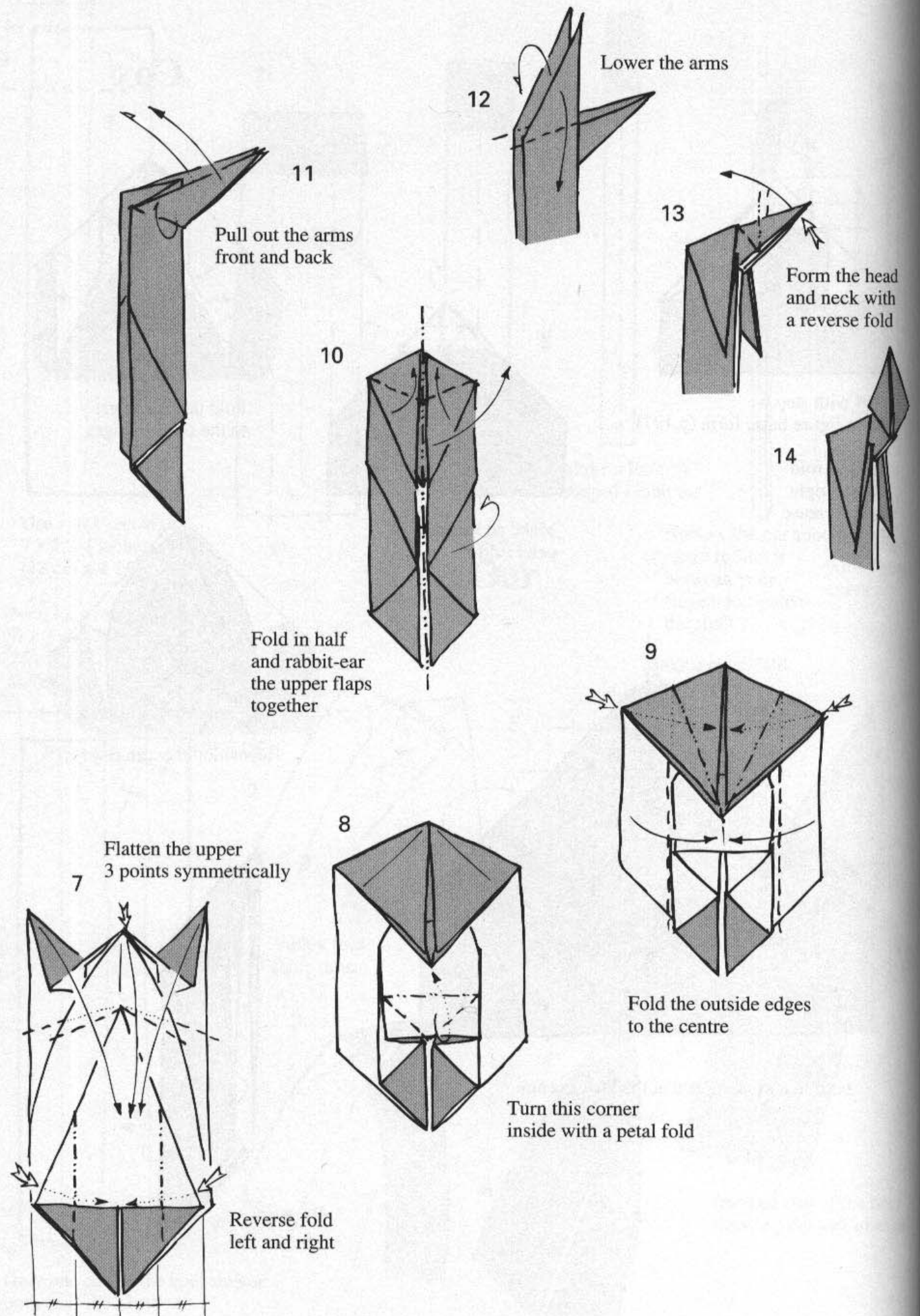

15

Open all layers of the head and valley fold down

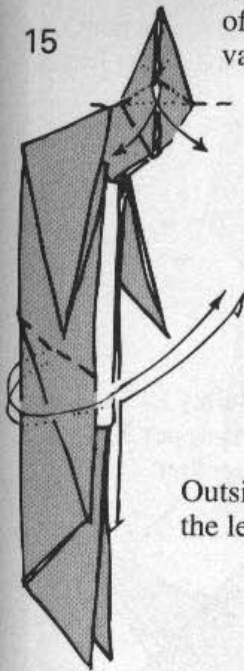

Outside reverse fold the legs upwards

16

Lift and open the upper part of the head

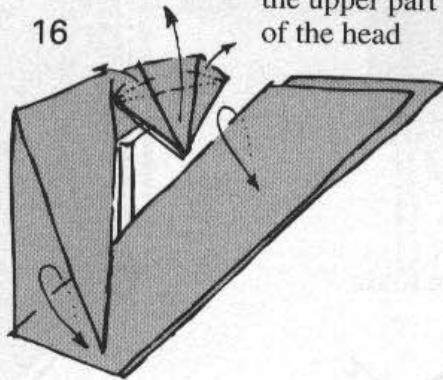

Pull out the inner layer of the leg to make the outside white, and repeat behind

17

Formation of the cap

18

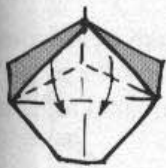

19

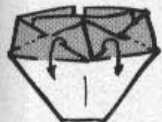

Reverse fold the hands

Pleat the feet, then fold the legs down

Shape the arms with a soft mountain fold

20

Adjust the position of the body by pulling it back slightly so that the figure sits easily

Narrow the legs

Open the hands

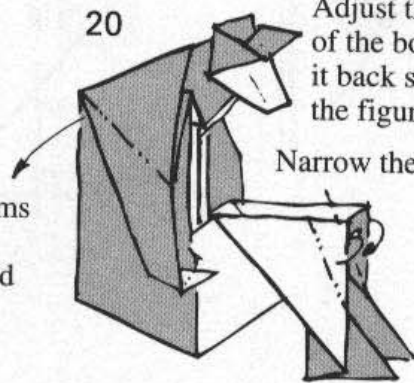

The Oxford and Cambridge Boat Race

This historic event takes place every spring on the River Thames in London. The crews are from the universities of Oxford and Cambridge, and are identified by their colours of dark and light blue respectively.

To make an origami version of the Boat Race, (see pp.12 & 13) make two boats, with eight oarsmen for each boat. The cox faces the oarsmen whose oars are arranged alternately left and right.

Three Wise Men

See p.15 for a photograph of the Wise Men scene which is completed by the Square Silver Star (p.232)

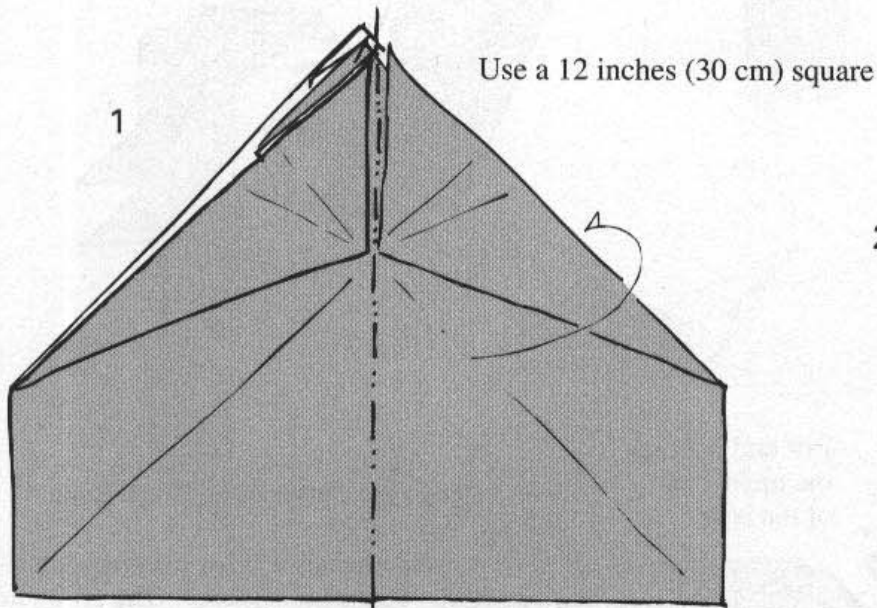

Start with step 5 of the Cox

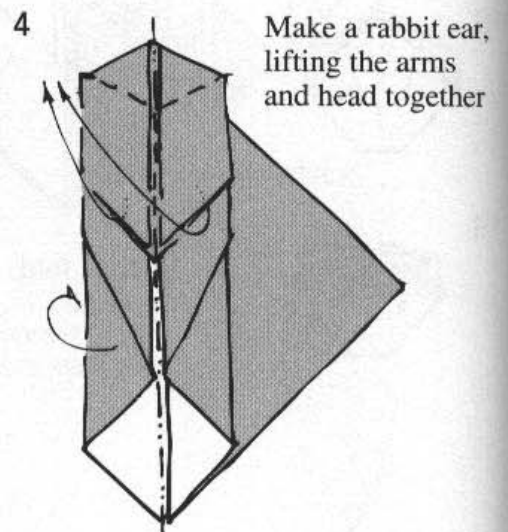
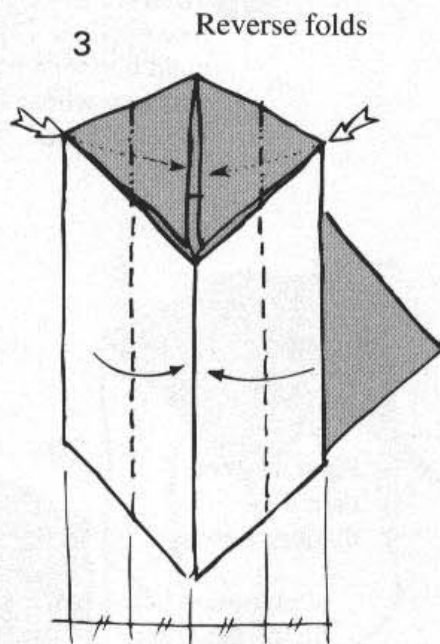
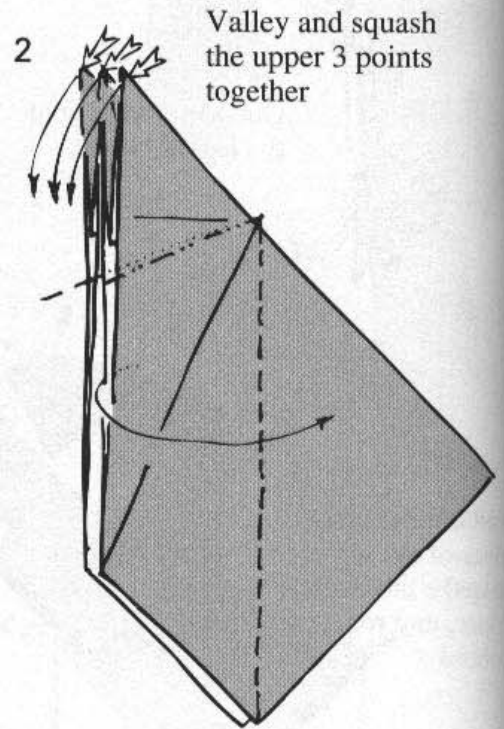

Open all the layers
and valley fold down

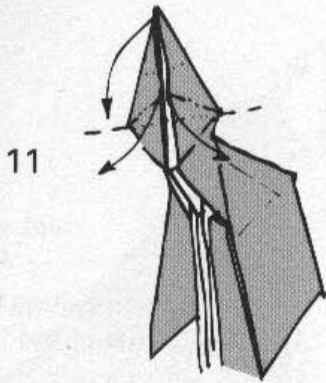

11

12

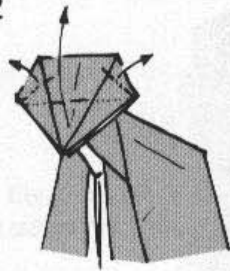

Open the upper part
of the head

13



Fold the face
in half

14

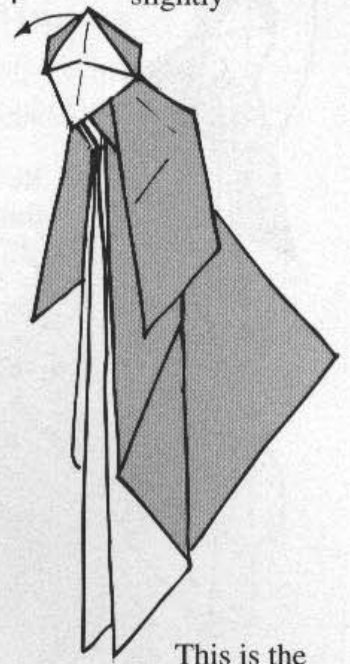

Adjust the head
by pulling forward
slightly

10

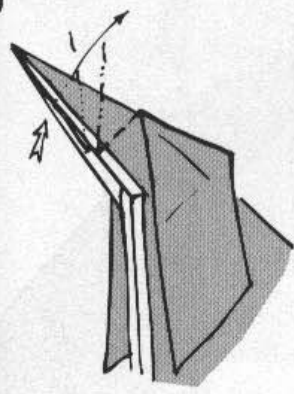

Reverse fold the head

9

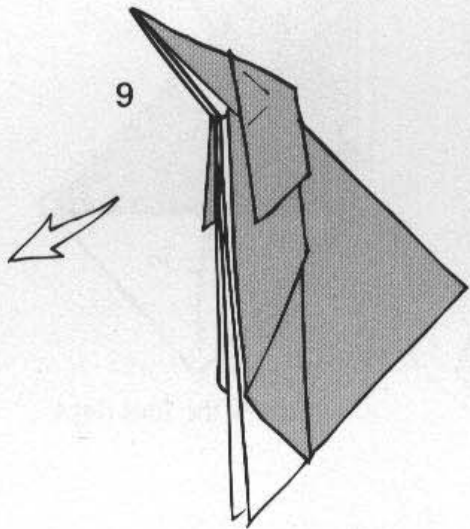

This is the
starting point
for all three
Wise Men

8

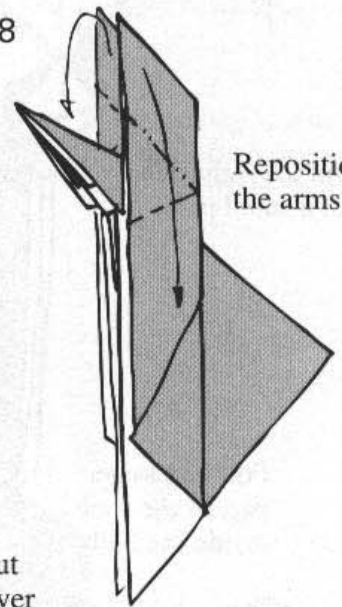

Reposition
the arms

7

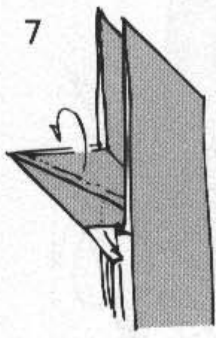

then pull out
a single layer
from inside

6

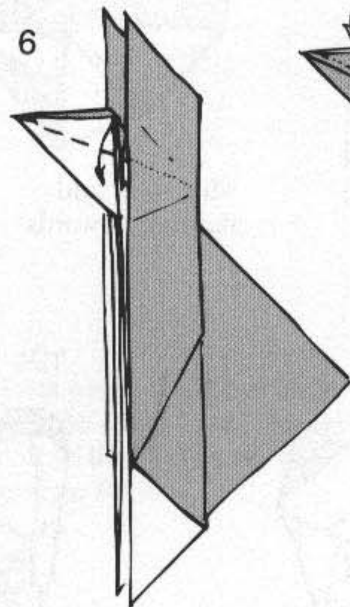

Narrow the head

5

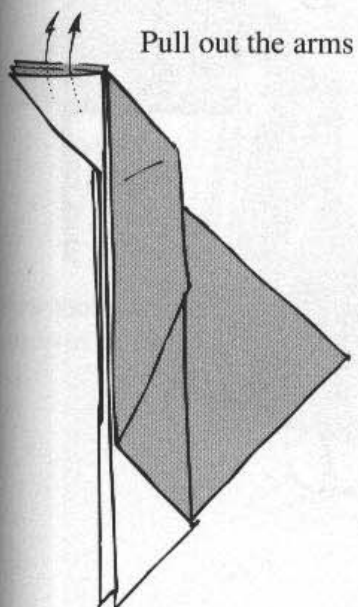

Pull out the arms

Wise Man I

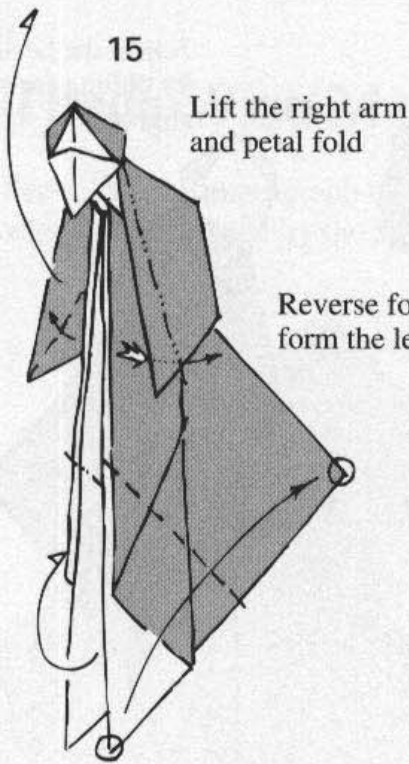

15

Lift the right arm and petal fold

Reverse fold to form the left hand

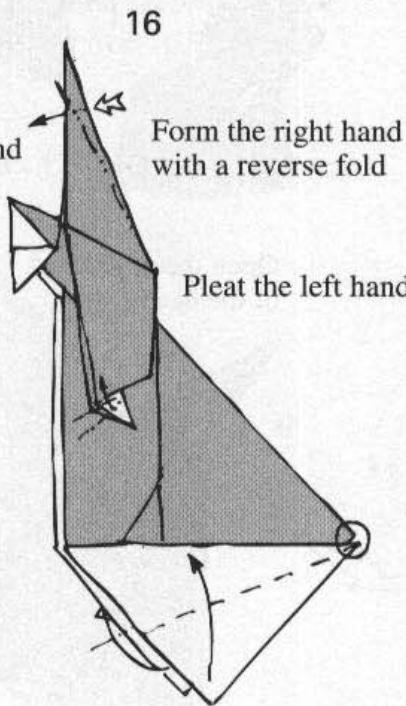

16

Form the right hand with a reverse fold

Pleat the left hand

17

Reposition the right hand

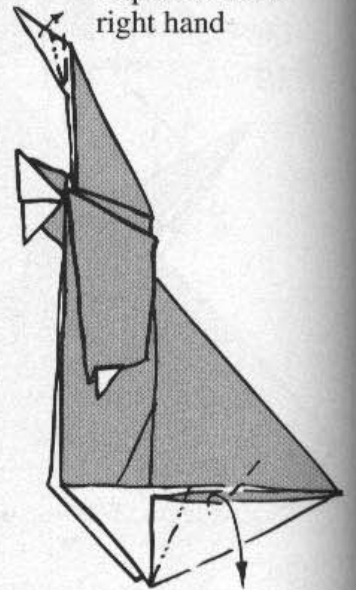

Open the foot flap

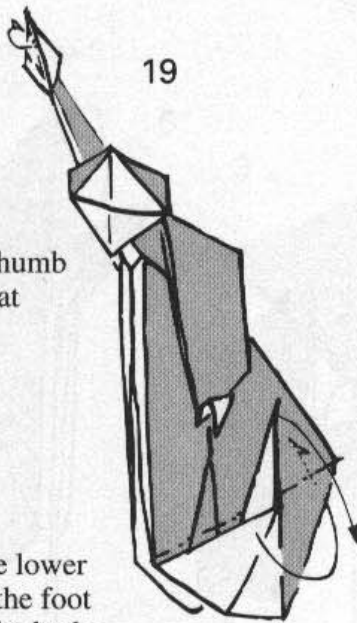

19

Form the right thumb with a small pleat

Fold the lower part of the foot inside the body

18

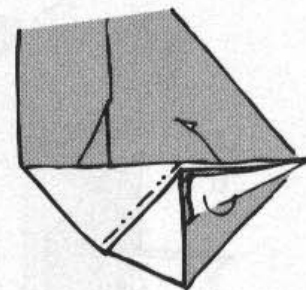

Mountain fold the foot upwards

20

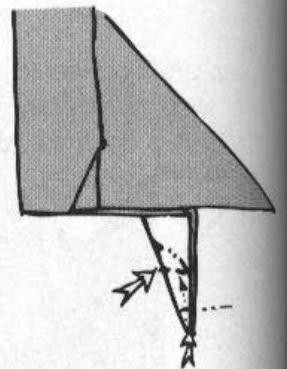

Form the foot with a series of reverse folds

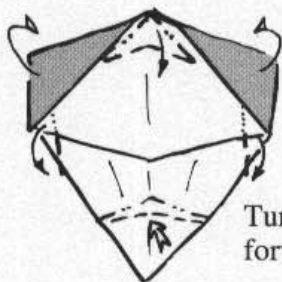

19a

Turn the ears forward

Formation of the head:
Crimp the nose/jaw line

Lower the tip of the head with a rabbit ear

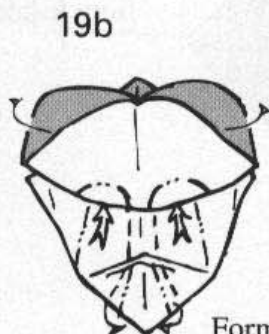

19b

Form the eye sockets
Pleat the beard,
and make the whole head rounded

19c



Wise Man II

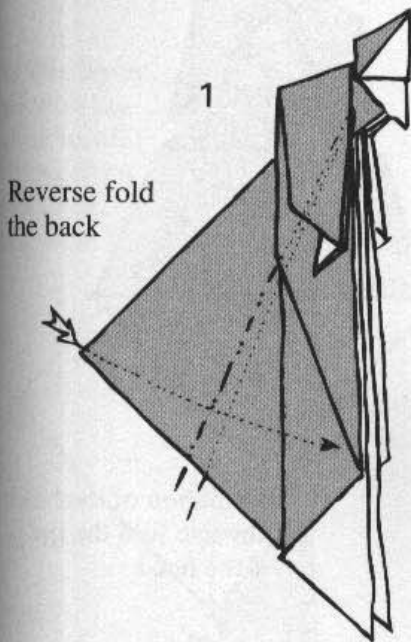

Reverse fold
the back

Start from step 15
of the 1st Wise Man

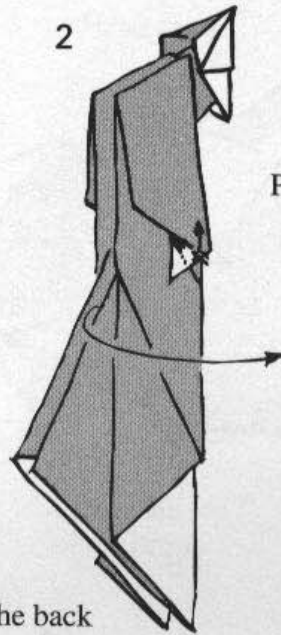

Open the back

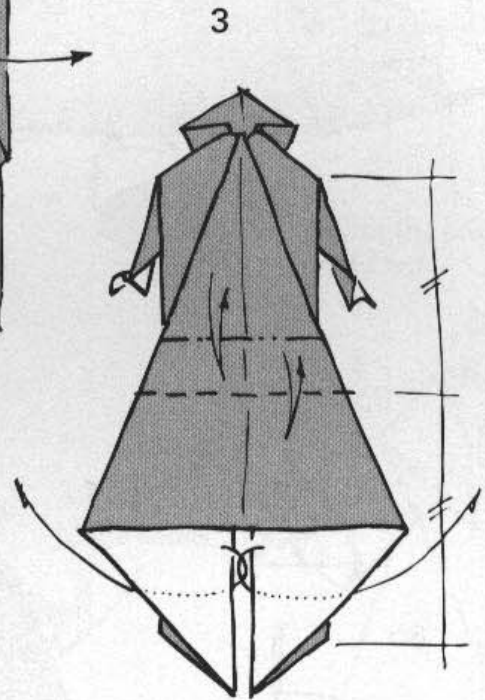

Pleat the hand

Precrease the waist-
line folds then open
from the front

21

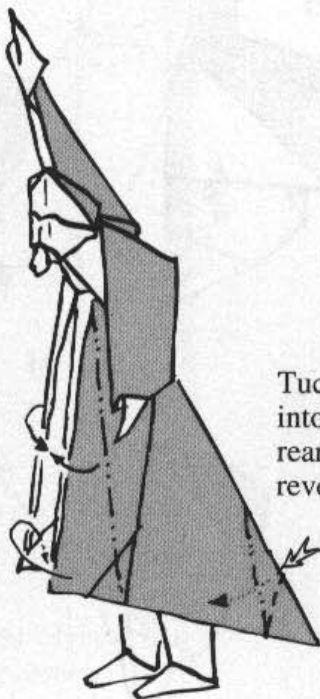

Tuck one side of the cloak
into the other: Form the
rear of the cloak with 2
reverse folds

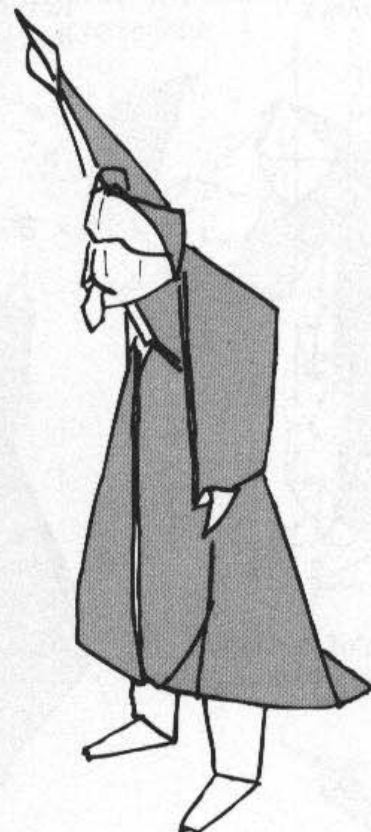

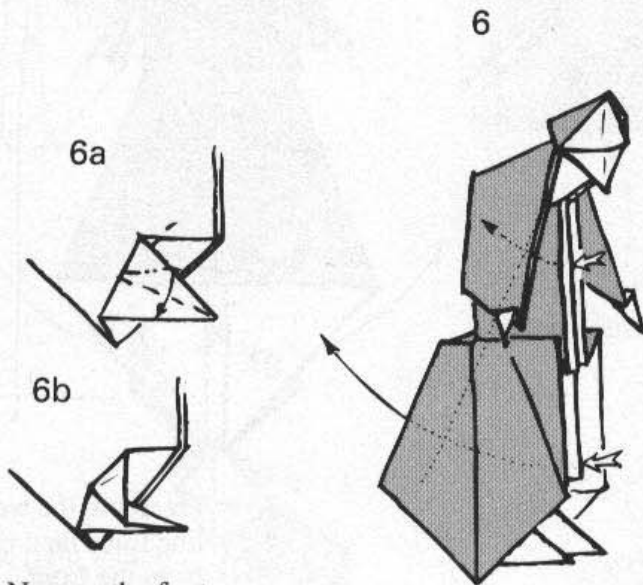
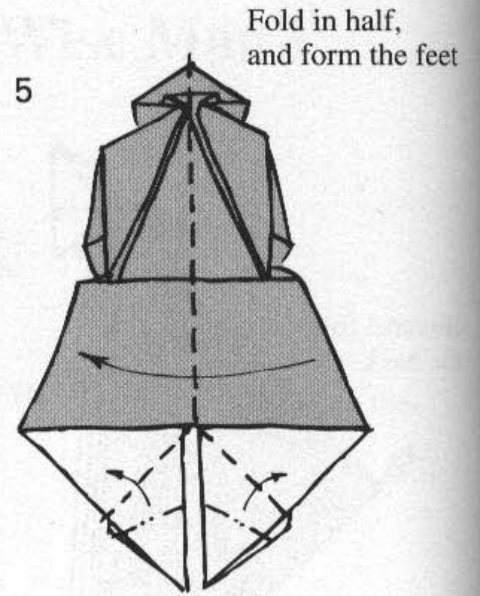
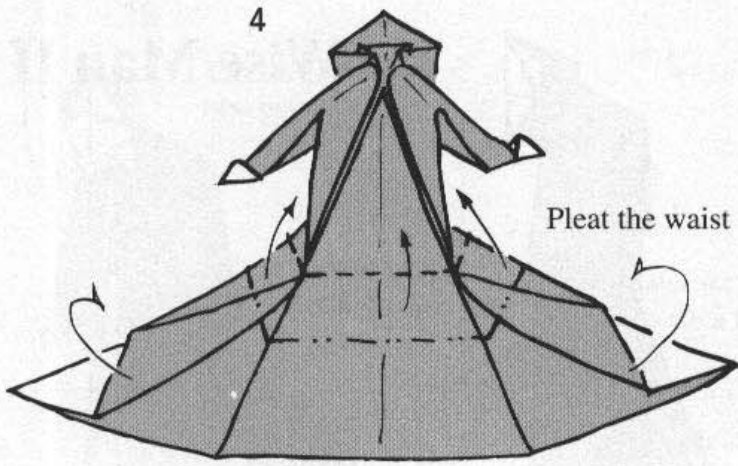

Formation of the head:
Reverse fold the tip
of the head ...

Narrow the foot
(inside view)

Reverse fold out
the centre layer

.. then lock by inserting
one side into the other

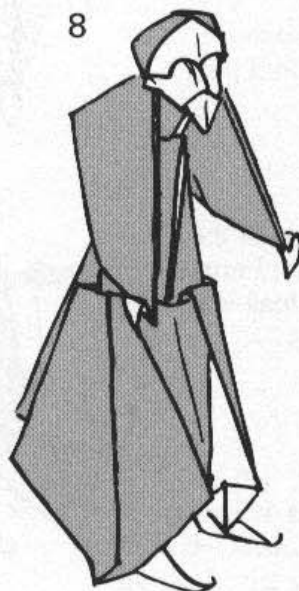
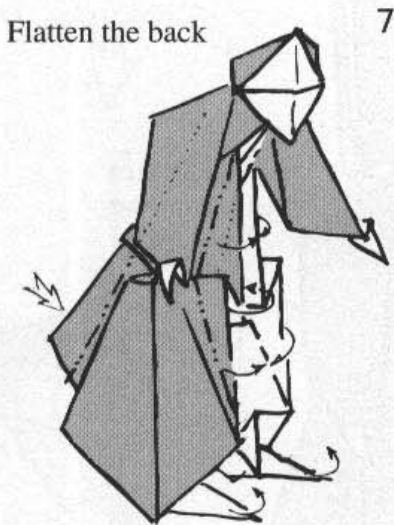

Narrow the front of the figure
then interlock the waistline layers

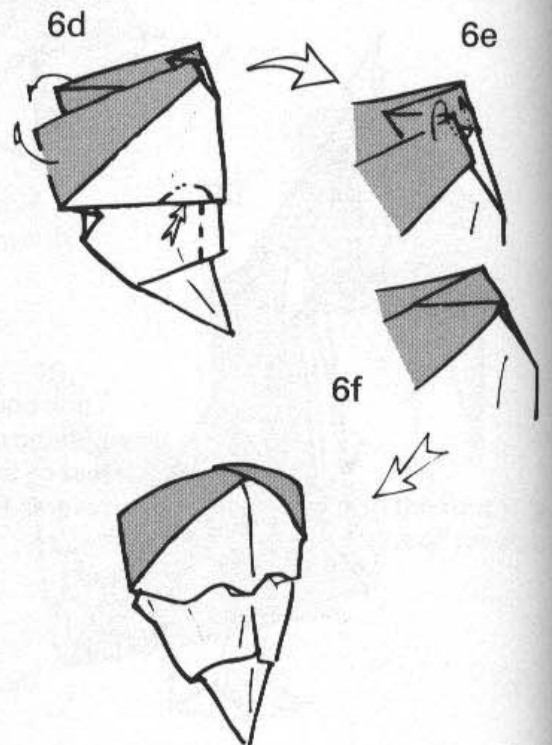

Wise Man III

For this figure fold with the colour inside starting from Step 15 of Wise Man I

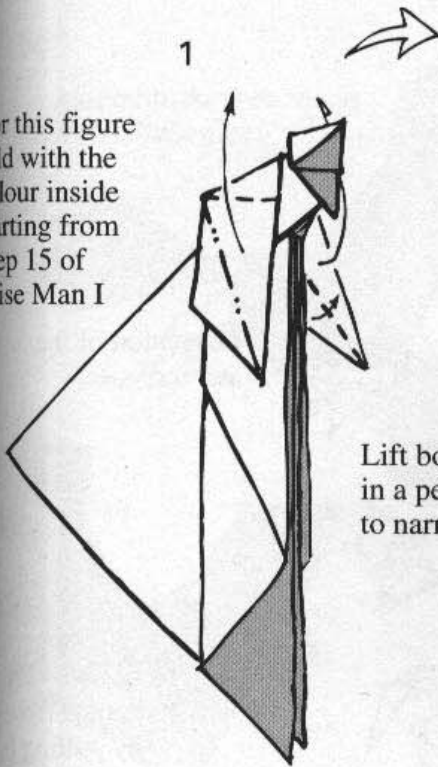

Lift both arms in a petal fold to narrow them

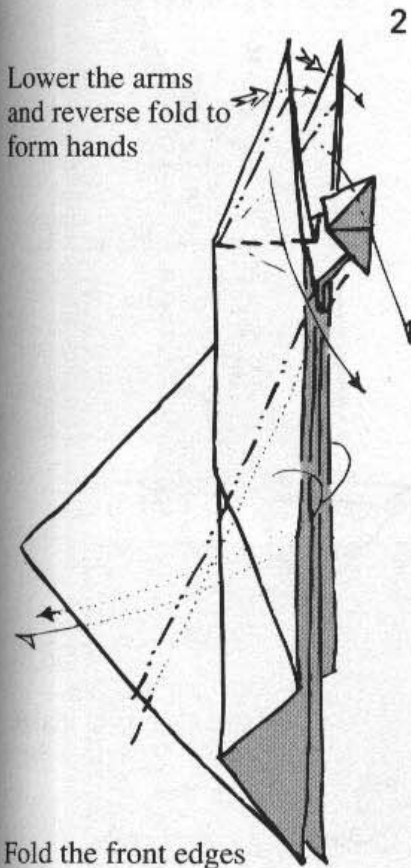

Lower the arms and reverse fold to form hands

Fold the front edges of the figure inside

Head details:

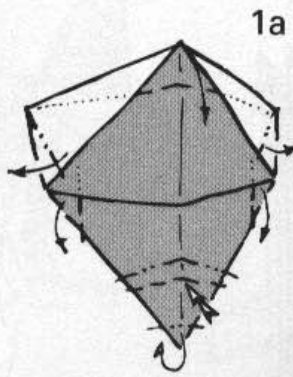

Lower the top of the head

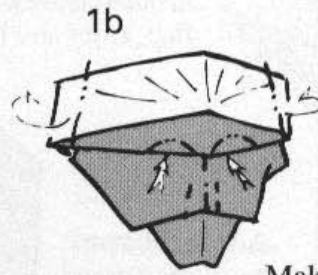

Make the whole head rounded



Adjust the position of the arms



Adjust the position of the hands

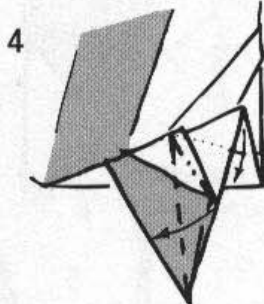

Pleat the feet

Formation of the foot seen from inside

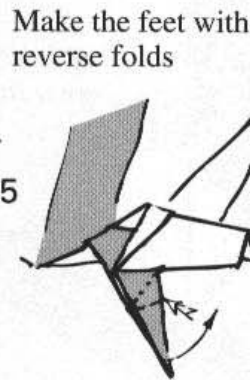

Make the feet with reverse folds

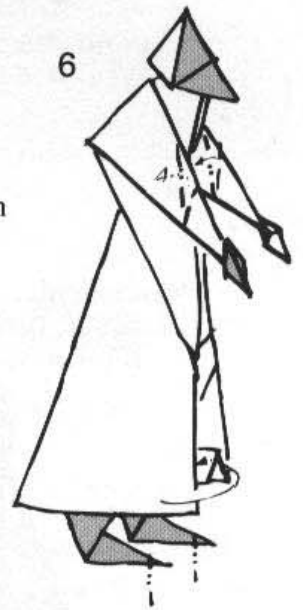

Tuck one side of the cloak inside the other



Hallowe'en Witch

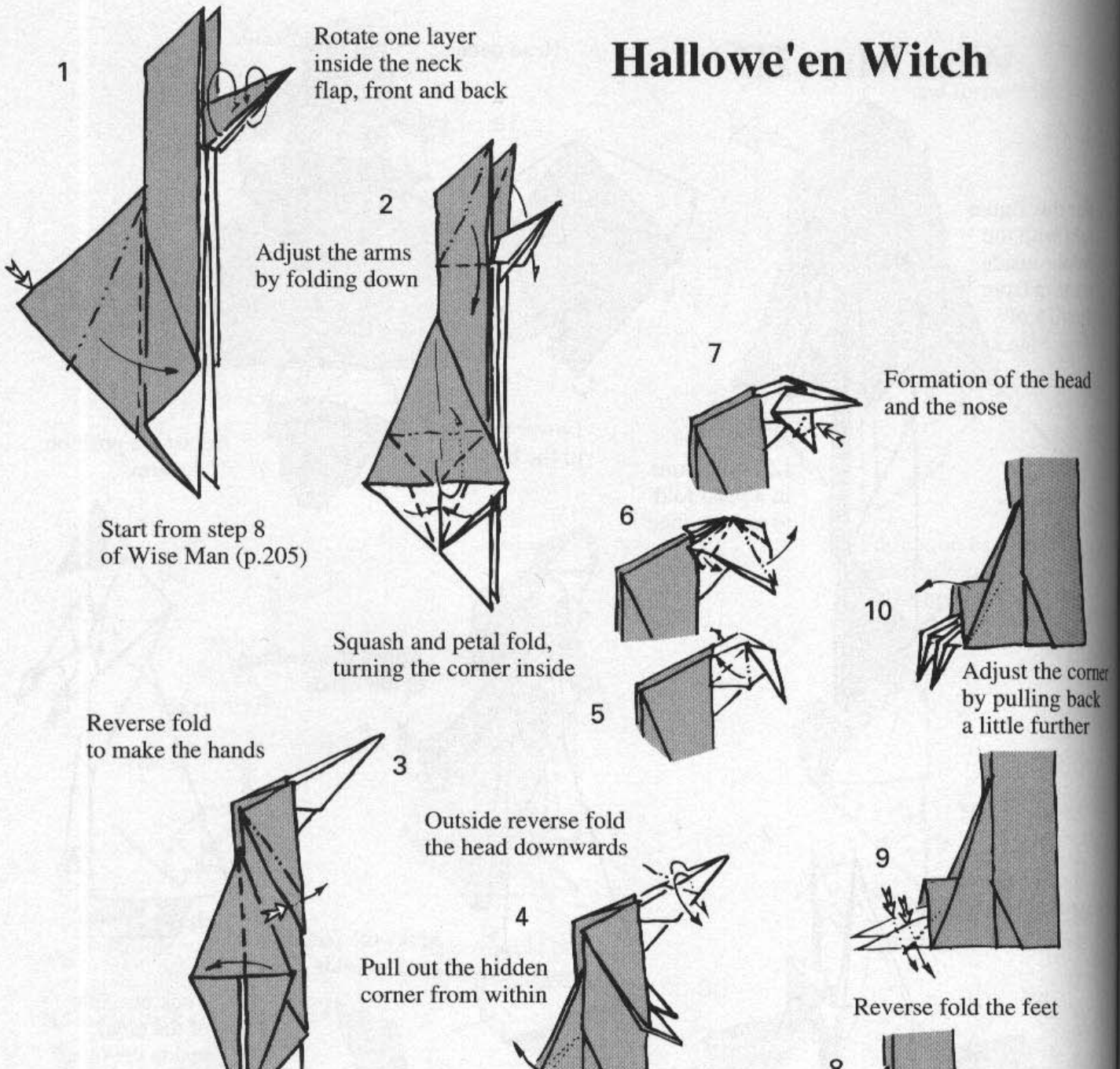

Start from step 8 of Wise Man (p.205)

Hat

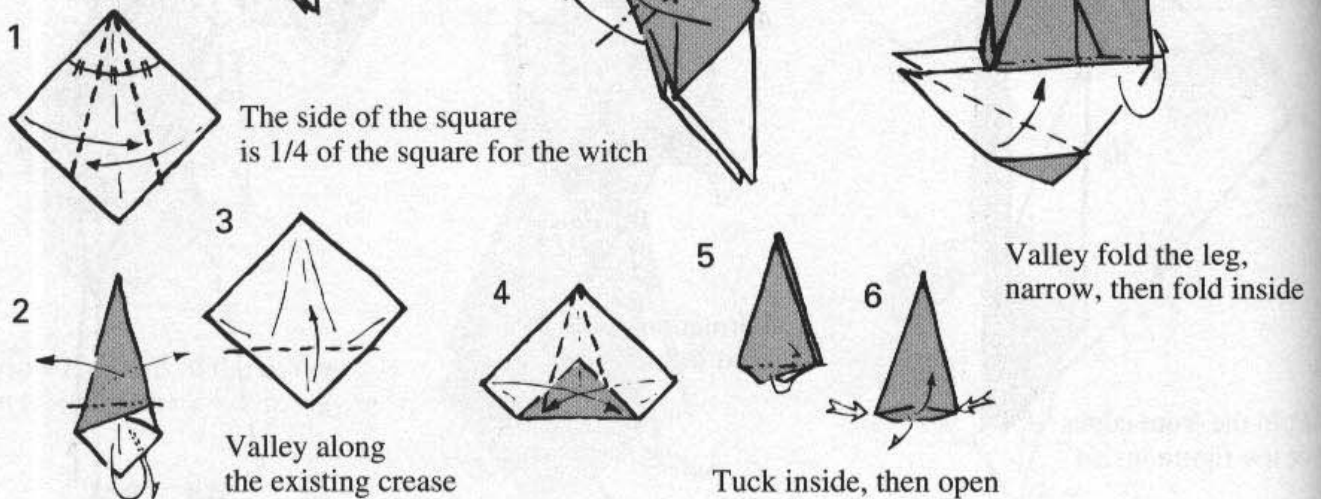

Assemble the 3 elements with a little glue

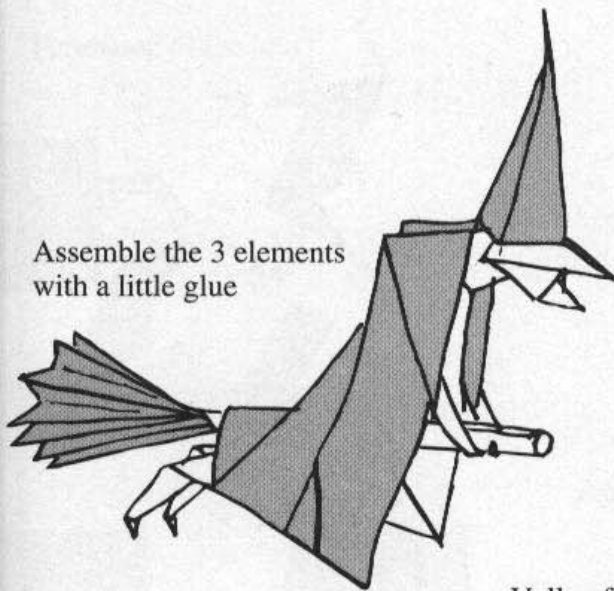

12 Roll up the 2 layers tightly together to form the handle

11 Spread the brush

10 Fold the layers around the brush part

Valley fold 2 flaps in front, Mountain fold 1 flap behind and reverse fold the remaining layer

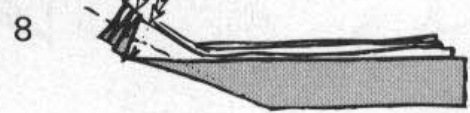
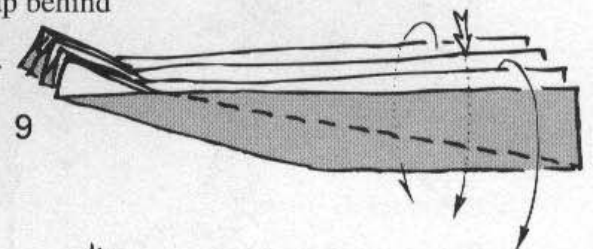

3 reverse folds

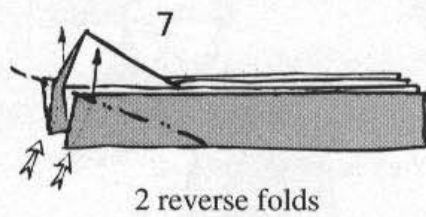

2 reverse folds

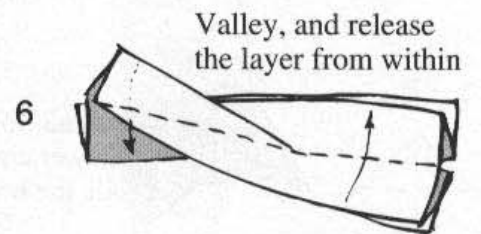

Valley, and release the layer from within

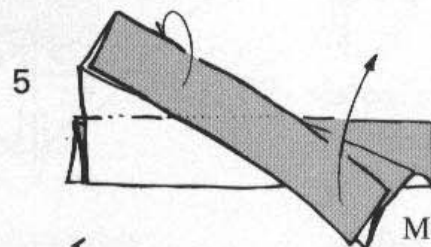

Mountain fold behind allowing the other layer to swing upwards

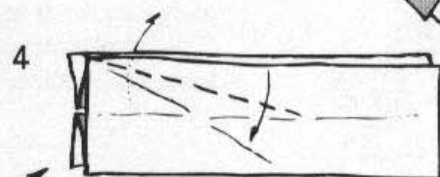

Valley fold to the existing creaseline

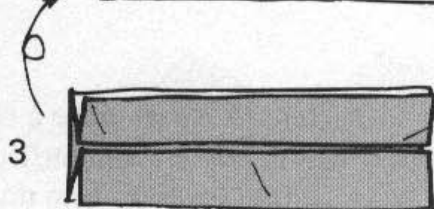

Broomstick

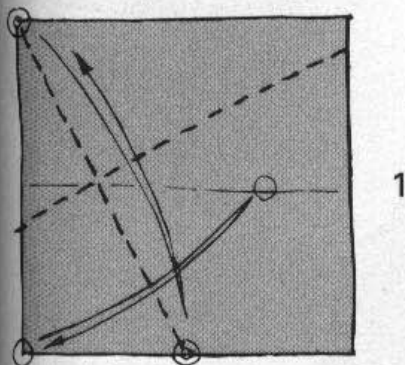

The side of the square is 5/8ths of the square for the witch

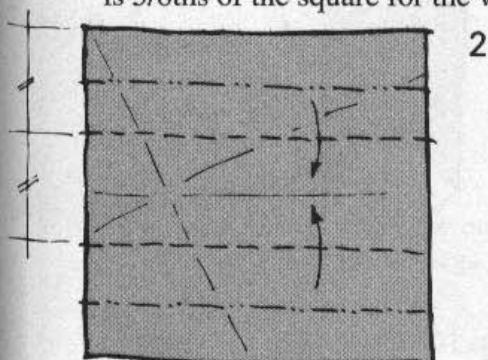

Precrease as shown to divide into thirds then sixths

Showjumper

1

Start with the Wise Man
Step 8, p.205.

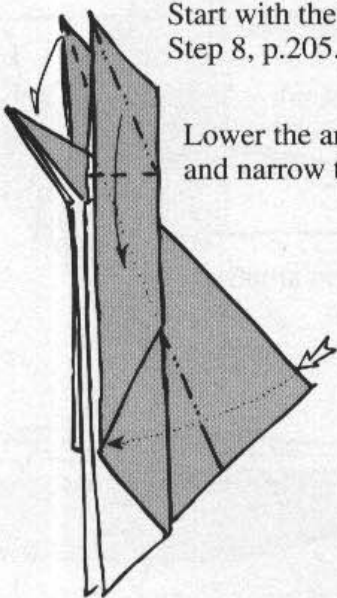

Lower the arms
and narrow them

Reverse fold the back

2

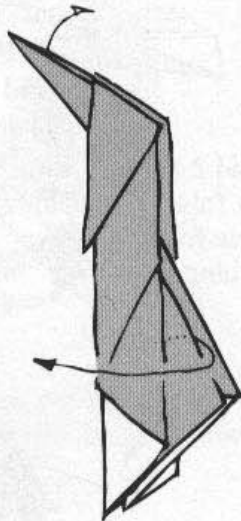

3

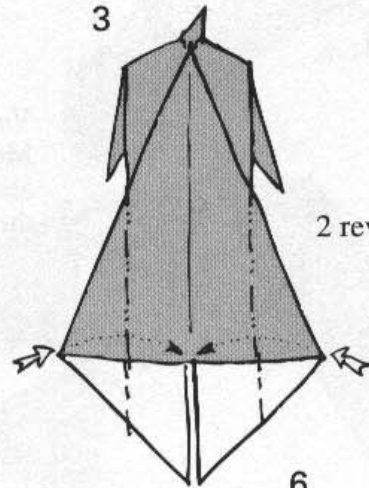

2 reverse folds

6

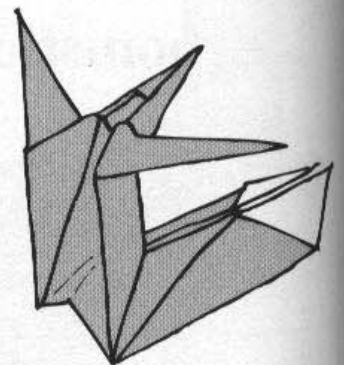

4

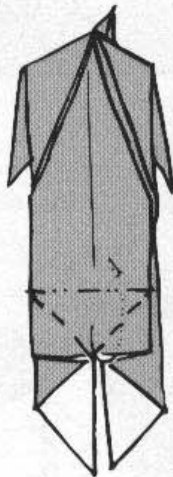

Mountain fold
the lower corner
inside the body

5

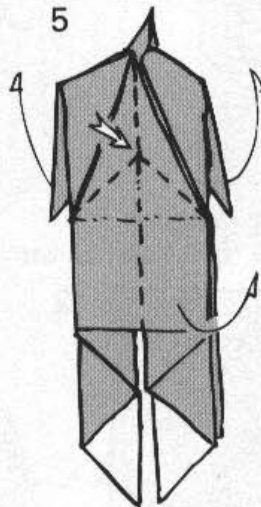

Collapse the figure
to a sitting position

To complete the Show jumper scene, make a Horse (p.168), and add a small fence: I used a variation of Fujimoto's cube to make the upright gate posts, adding strips to form the bars of the gate.

Formation of the foot

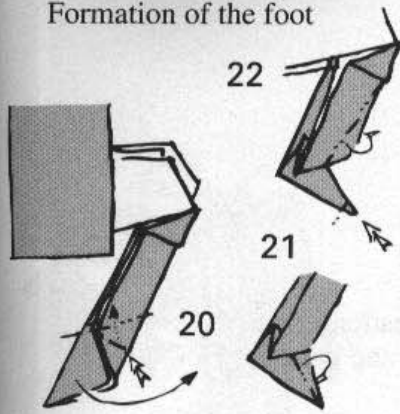

Shape the figure so it can sit on the horse

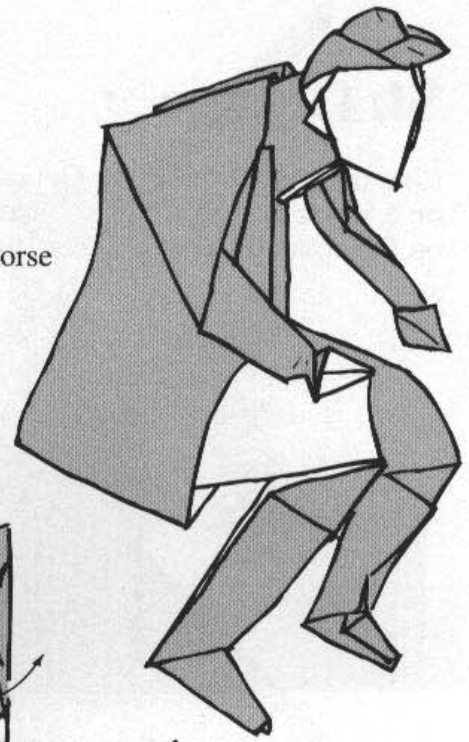

Arm shaping folds

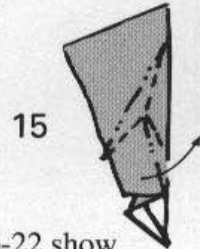

Diagrams 16-22 show the right leg only

16

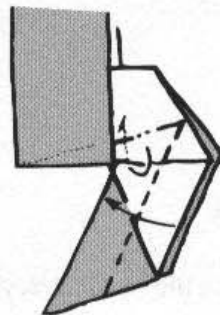

Narrow the leg inside and out

Open the head

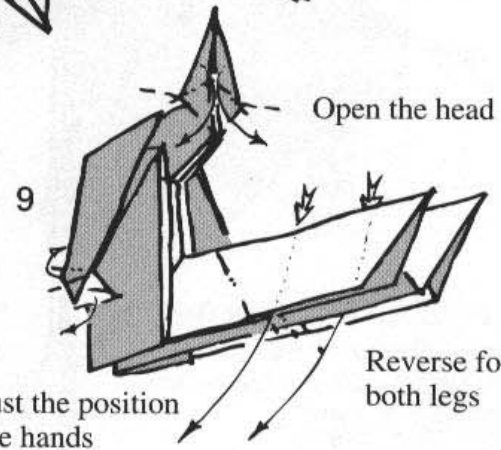

Adjust the position of the hands

Reverse fold both legs

Squash fold the head (see 9)

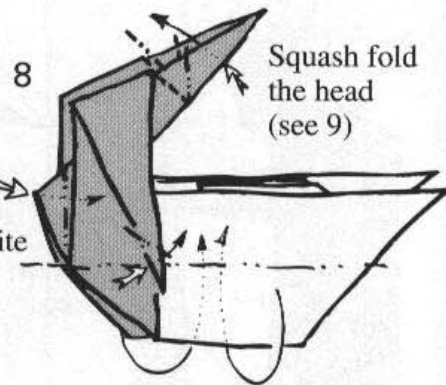

Squash the hands so they become white

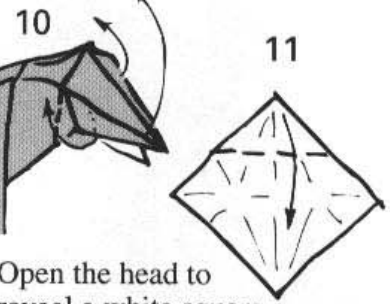

12 Open the head to reveal a white square

Narrow the legs again by mountain folding into the nearest pocket

Valley fold the cap

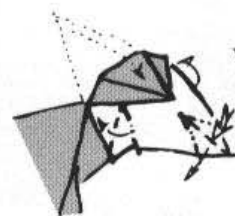

Form the chin with a reverse fold

Pull down the outer layer of the legs

Push out the central single layer

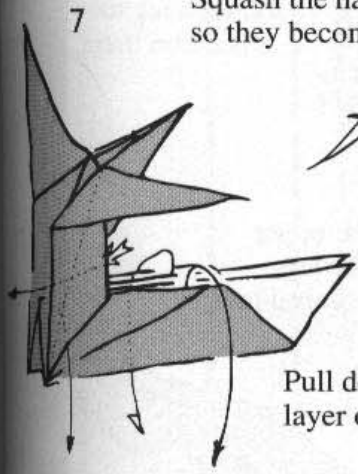

14



Form the peak of the cap with a small pleat

13



Form ears with a crimp on either side

St. George

Like the showjumper, St. George needs to be mounted on a Horse (p.168). The St. George and Dragon scene on the cover of this book is completed by a Dragon (p.172)

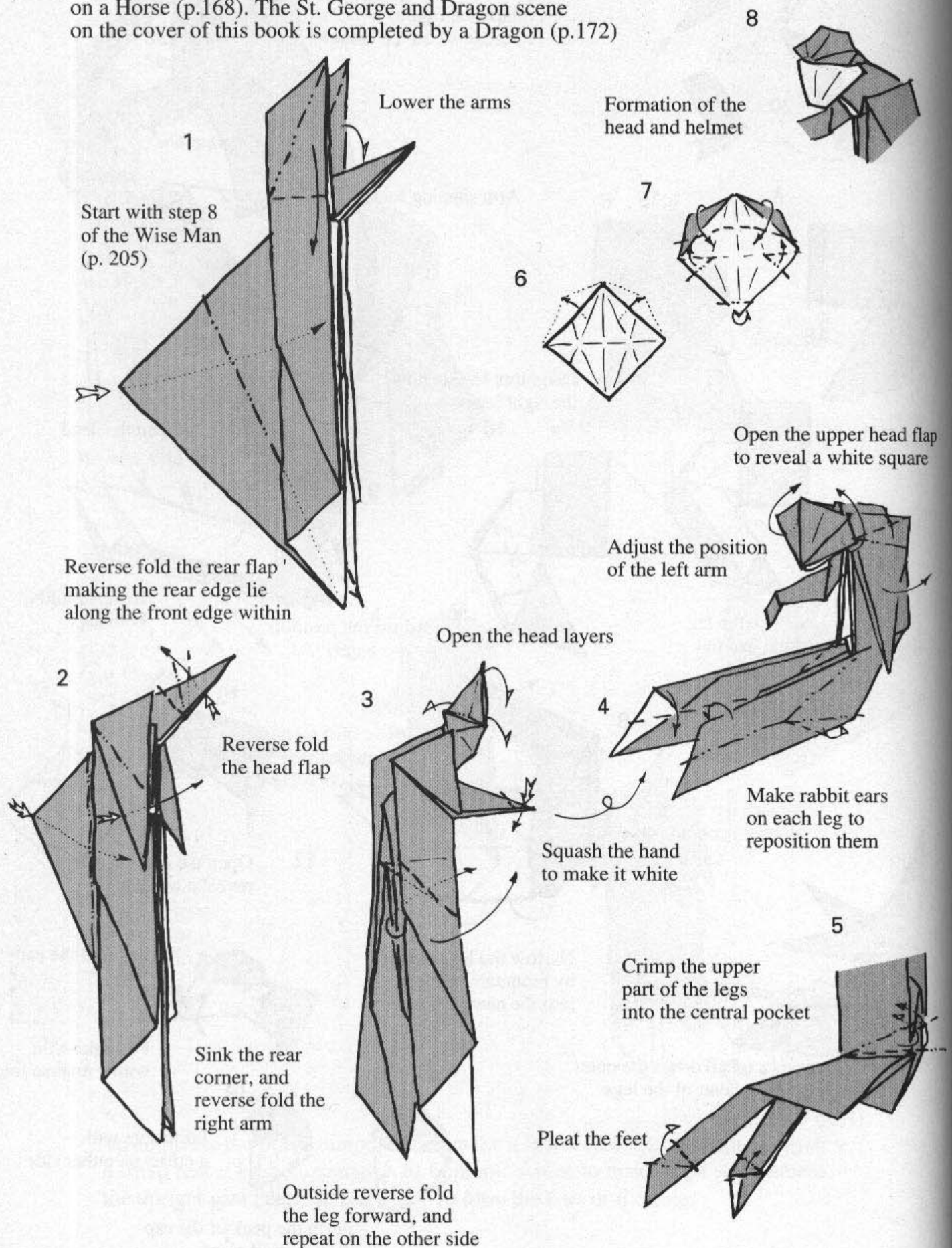

9



Fix the 3 elements together with a little glue, and pose the figure to suggest movement

Narrow the lower legs and feet

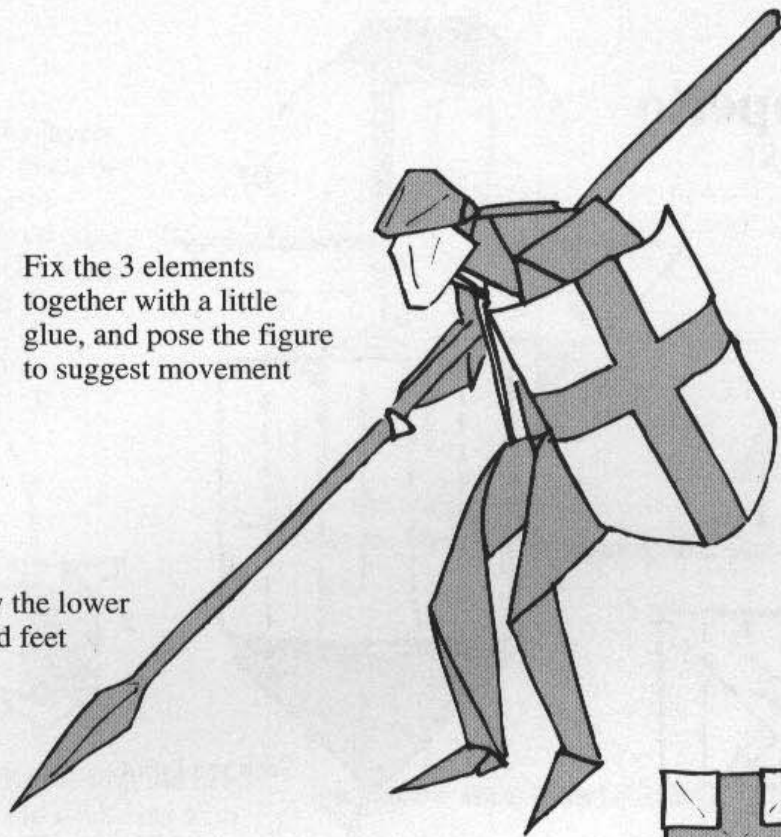

Spear

1

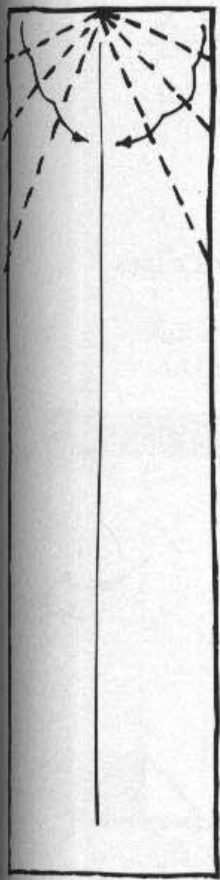

2

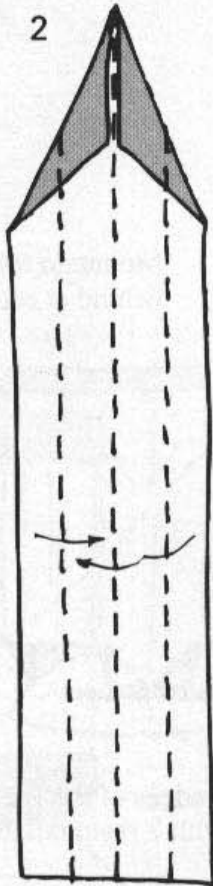

3



4



5

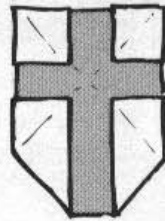

3

2

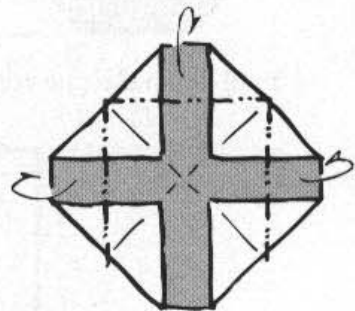

Shield

Blintz to leave a coloured cross

1

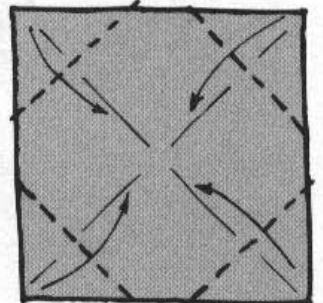

Use a square whose side is 1/3rd of that used for the figure

Use a 4x1 rectangle, the longer side being equal to the side of the square used for the figure

Narrow with successive rabbit ears

Roll the shaft tightly between thumb and forefinger

Geppetto

Start with a 2 x 1 rectangle:
suggested size 16 x 8 inches
(40 x 20 cm)

1

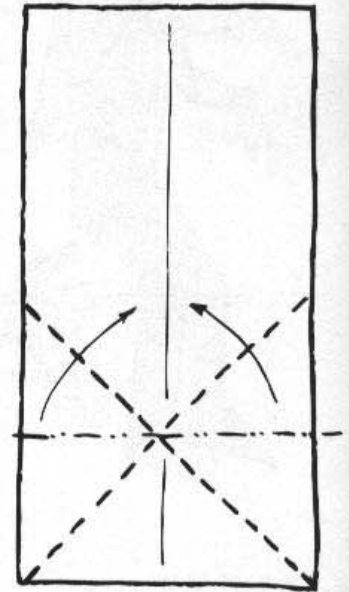

Fold a waterbomb base
at one end of the rectangle

2

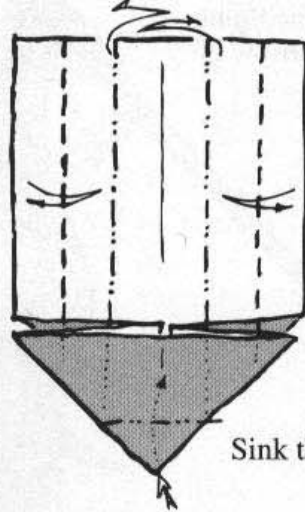

Sink the point

Precrease the other end
of the rectangle into 1/6ths

3

Precrease 2 diagonals

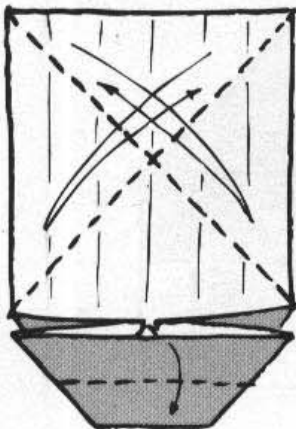

Fold down the raw edge

4

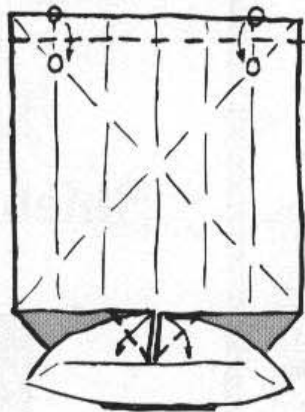

Valley fold the top edge
and the 2 central corners

5

Mountain fold the 2 edges
behind at each side

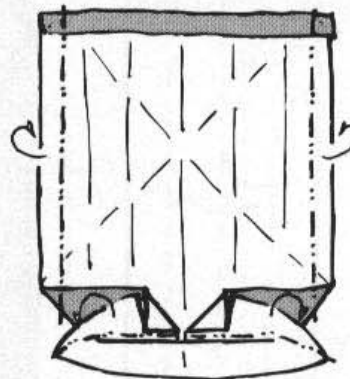

Turn the edges of the legs
behind with 2 mountain folds

Stretch the layers carefully to allow the center of the coloured edge to be lifted upwards. See 11 & 12.

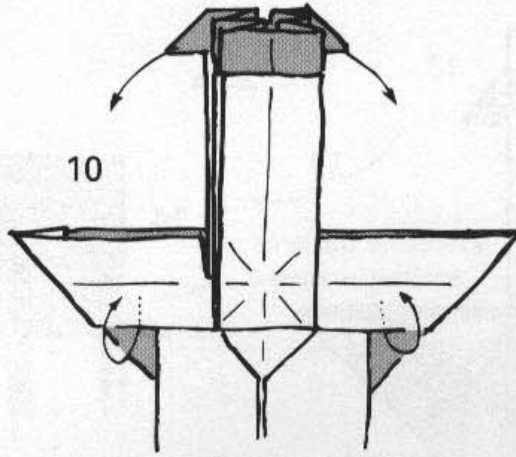

10

Tuck the ends of the arms under the layers below

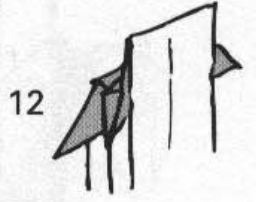

12

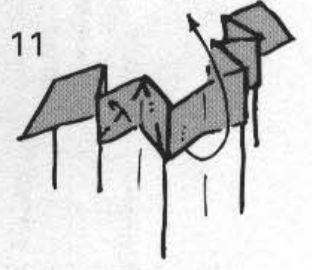

11

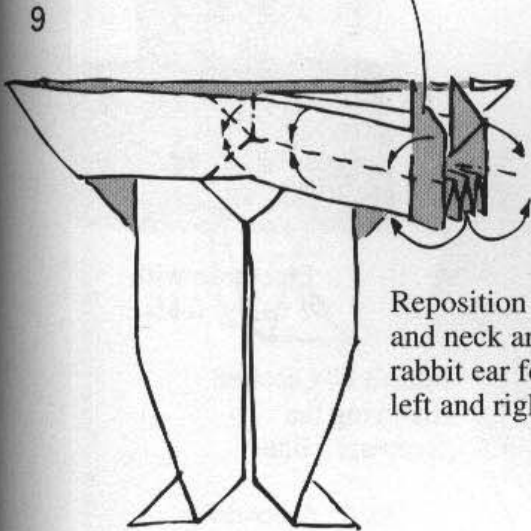

9

Reposition the head and neck area with rabbit ear folds left and right

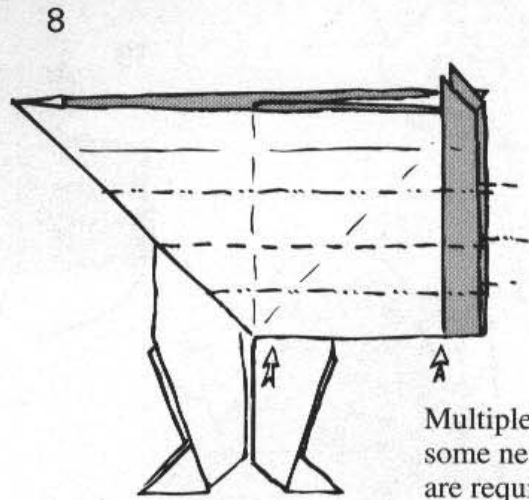

8

Multiple sink: some new creases are required

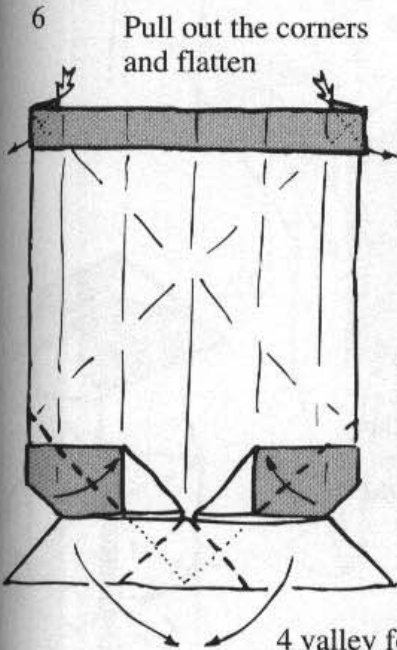

6

Pull out the corners and flatten

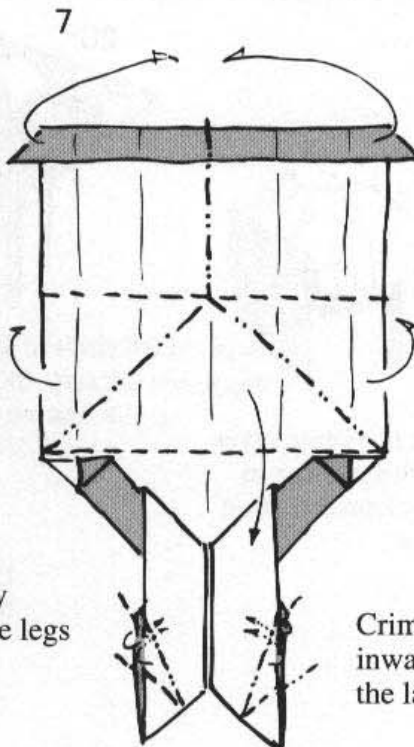

7

Form a rabbit ear on the upper part

4 valley folds to shape the body and reposition the legs

Crimp the feet inwards between the layers of the legs

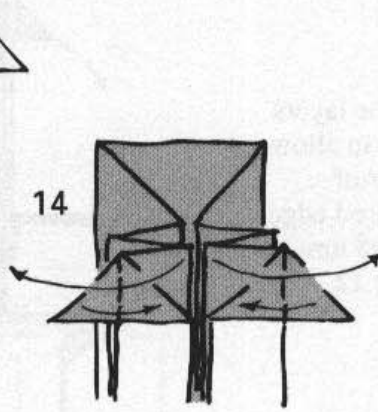
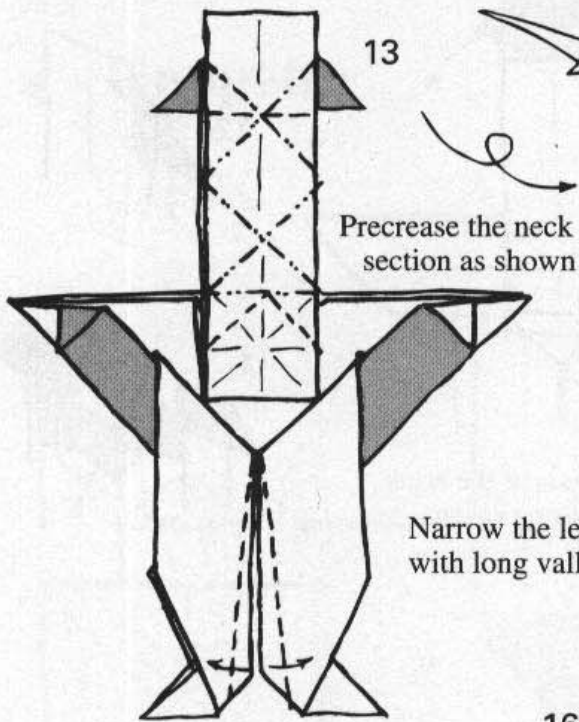

Valley fold the triangular flaps, then open the upper layer of the neck section

Narrow the legs with long valley folds

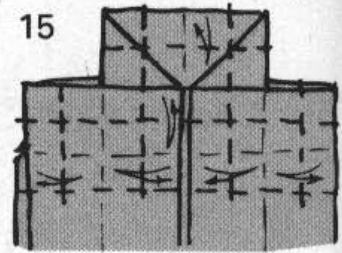

Precrease with 7 valley folds

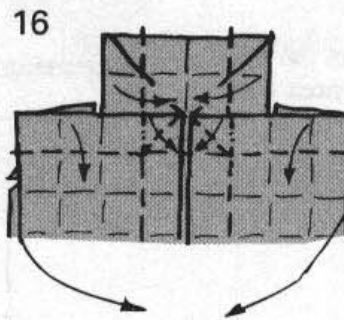

Form a box section following the preceased lines

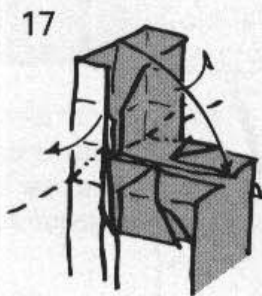

Flatten the vertical part, squashing left and right

Tuck in the base of the head to lock

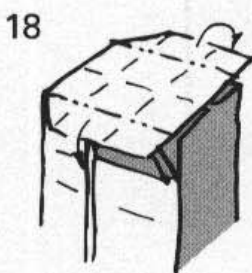
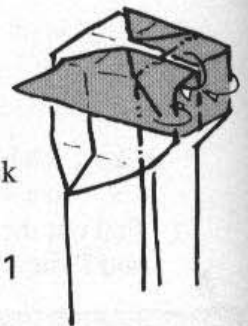

Mountain fold left and right

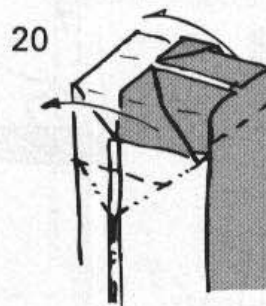

Raise the 2 triangular corners, then flatten the bottom part of the neck

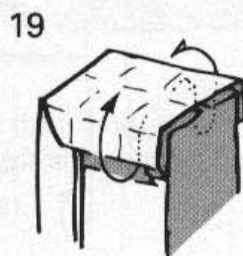

Tuck the white layer into the pockets in the coloured section below

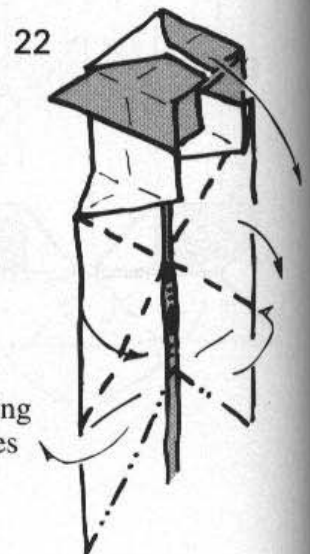

Form the neck using the existing creases

26

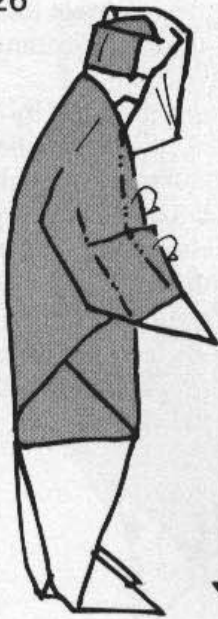

Lock the front edge of the arms with mountain folds

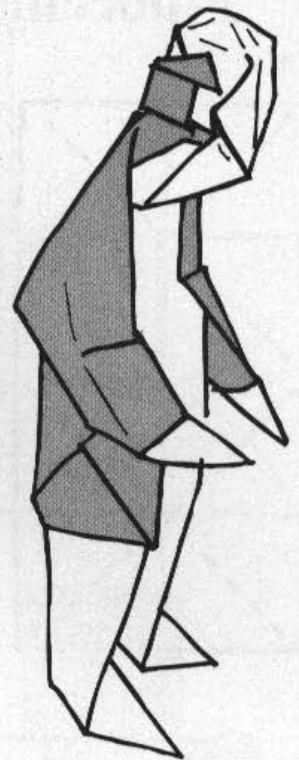

25

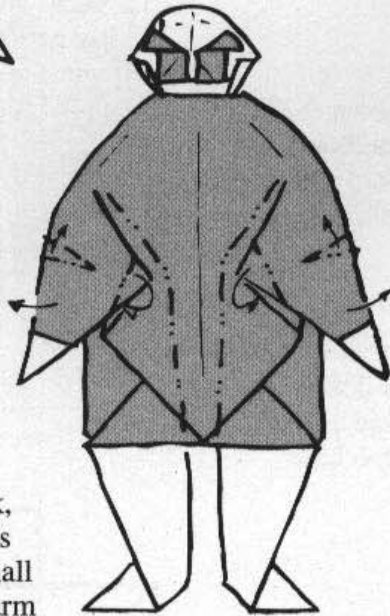

Shape the back, lock the elbows and make a small pleat on each arm

24

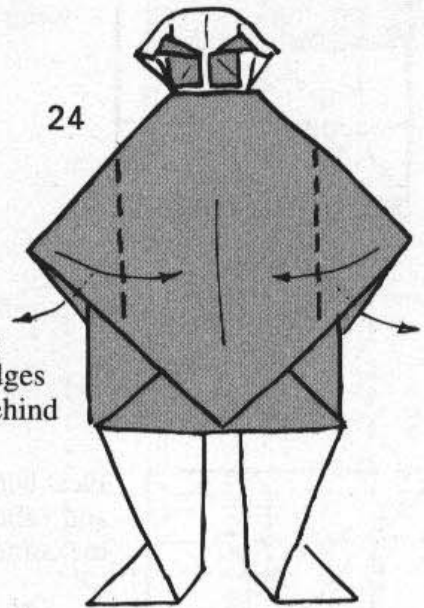

Valley fold the arms allowing the front edges to swing out from behind

23

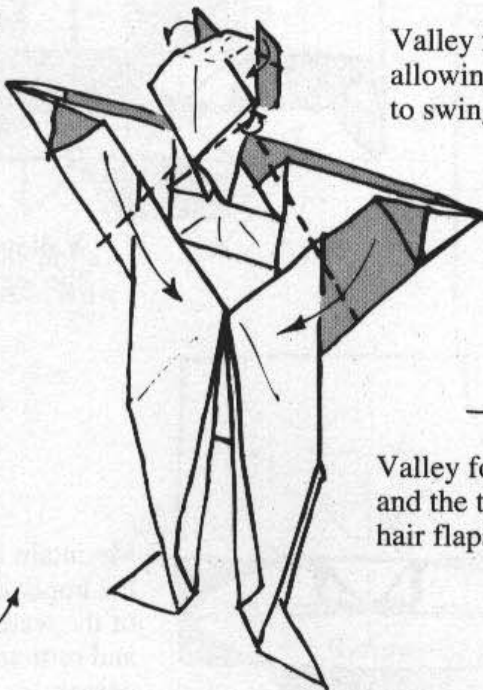

Valley fold the arms and the triangular hair flaps

Pinocchio

1

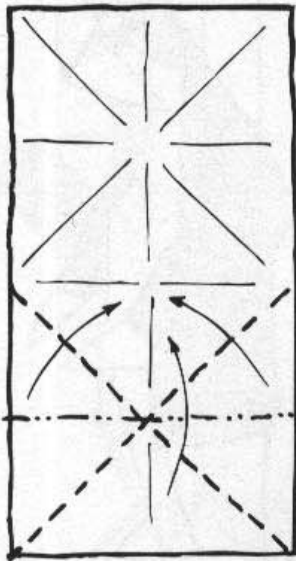

Start with a 2x1 rectangle
3/4 of the size used for
Geppetto

Precrease as shown,
then form a waterbomb
base at one end
of the rectangle

2

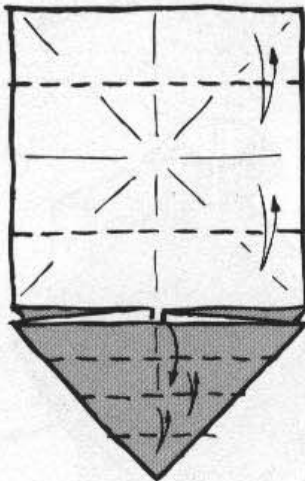

Precrease as shown
then fold down the
upper edge of the
waterbomb base

3

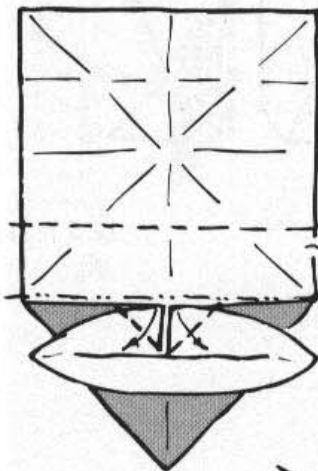

Pleat behind
and valley fold
the corners

4

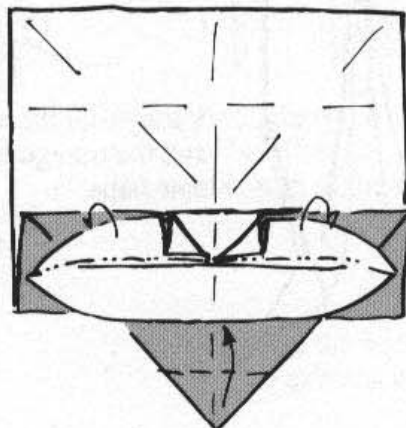

Mountain fold
the upper edge
of the waterbomb base
and turn up the lower
corner

5

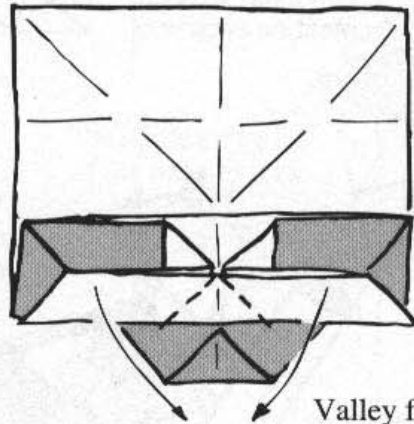

Valley fold
the legs down

The figures of Geppetto and Pinocchio were designed as entries for a competition organised by the Gentro Diffusione Origami in Florence, to celebrate the centenary of the Pinocchio story, written by Collodi in 1883.

The scene, completed by the Spelling Book (p.224), is taken from the beginning of the story. Geppetto, returns home in the snow, having sold his overcoat to buy a spelling book for Pinocchio. His excuse to the enquiring puppet is that he sold his coat because he was too hot.

My entry won the second prize in the Scene category of the competition.

See p.14 for a photograph of the scene.

8 Narrow the upper section

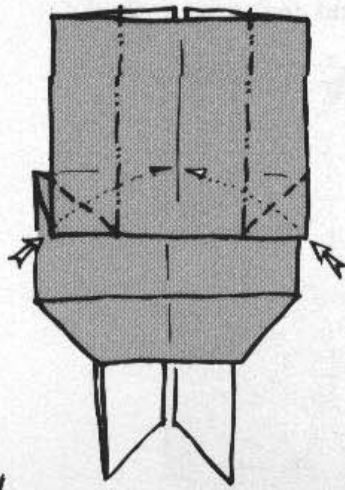

Precrease the hands and pleat behind

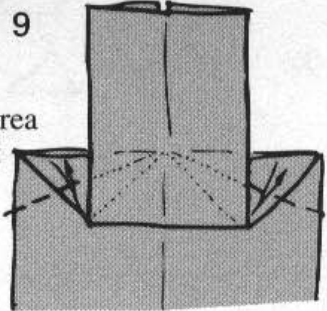

Precrease the shoulder area then open the upper part completely

7

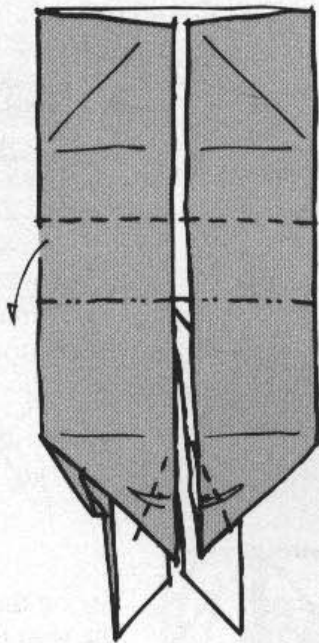

6

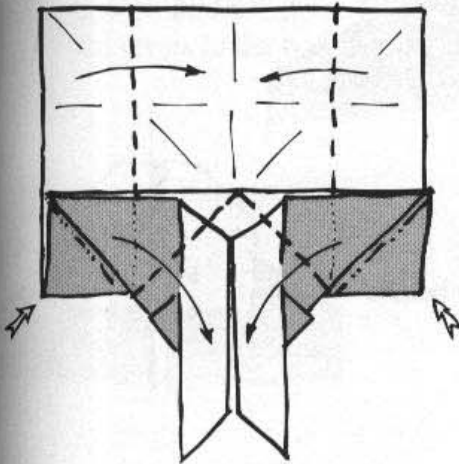

Narrow the body and form the arms

10

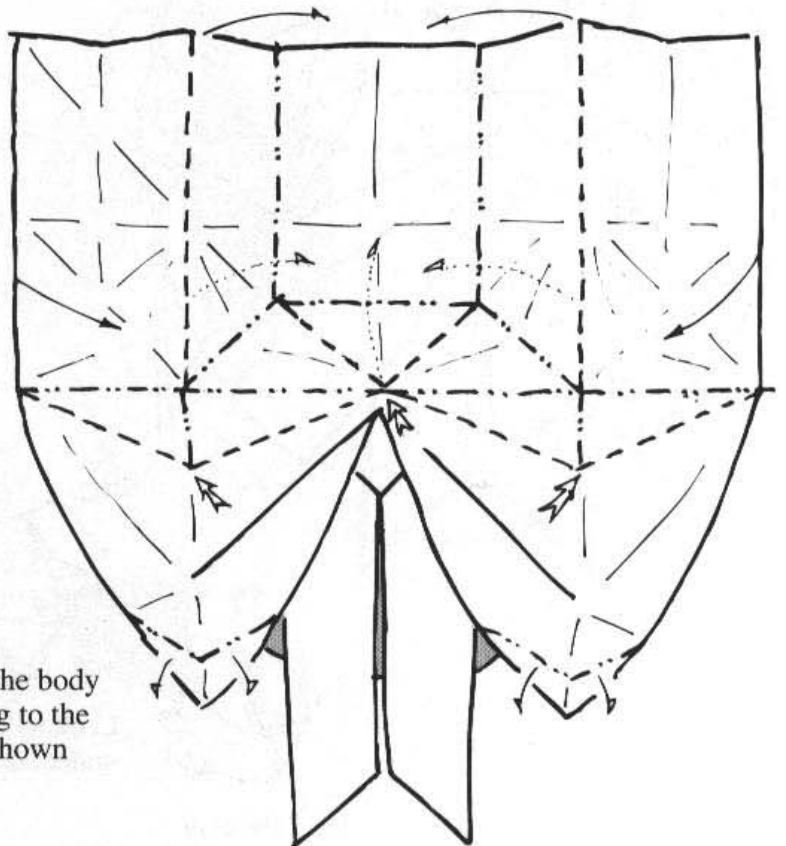

Reform the body according to the creases shown

Precrease the inside edges of the arms, and form the head and neck area as shown

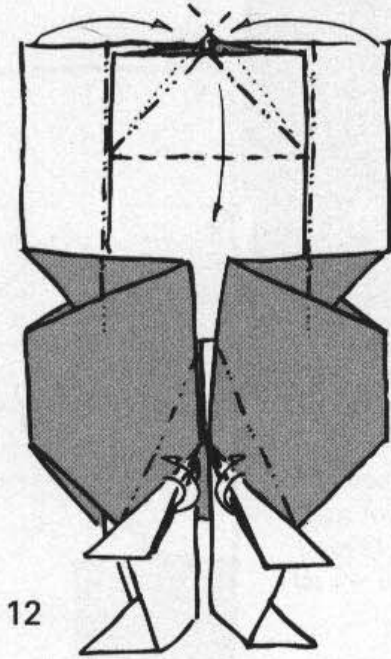

12

Formation of the nose:
Make a rabbit-ear, then narrow it as shown

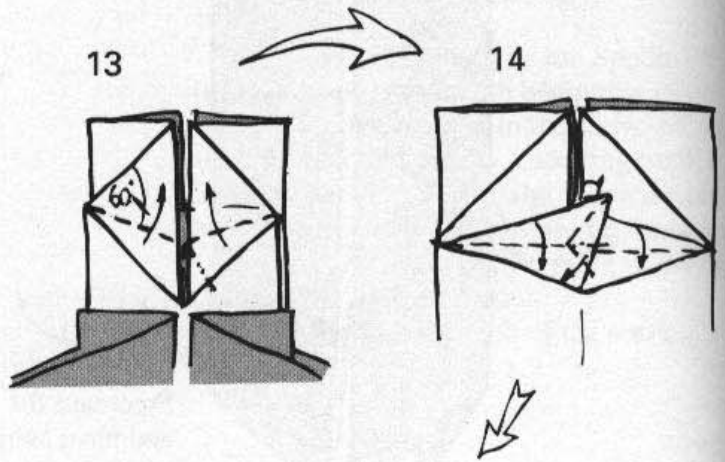

13

14

11 Continue to collapse the body then form the feet with crimps

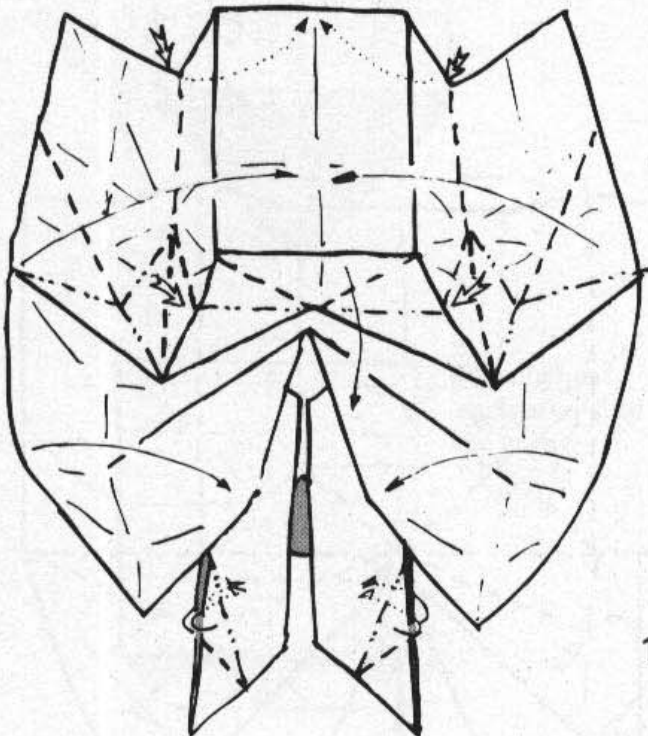

11

15 Swing the nose through the split in the face
Narrow the neck and valley fold the head forward

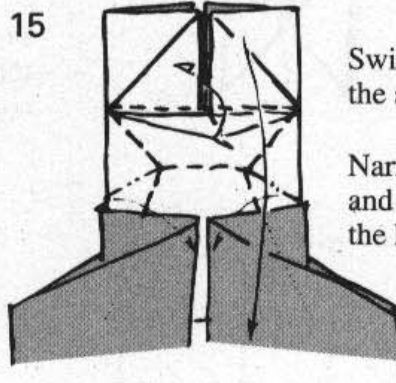

15

16 Tuck this corner behind

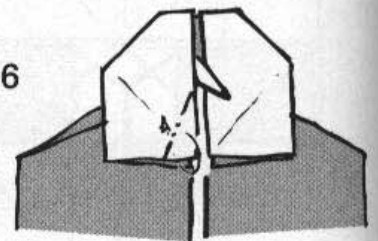

16

17

Insert one side of the chin into the other

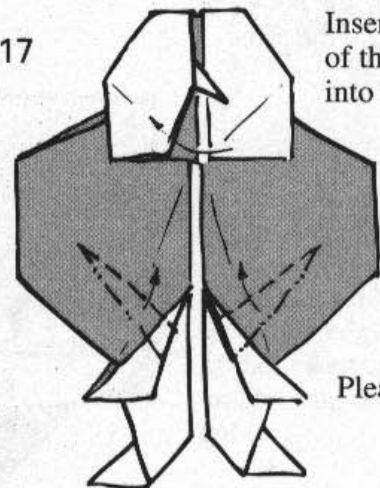

Pleat the arms

18

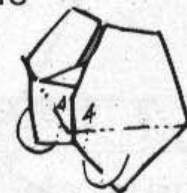

Lock by folding underneath

19

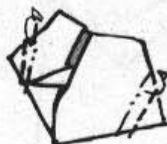

Pleat the ears

25

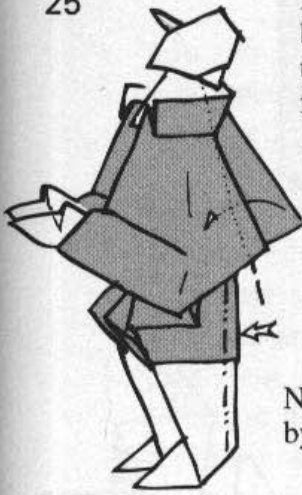

Lock the back by valley folding the right angled flap inside

Narrow the back of the legs by pushing in slightly



24

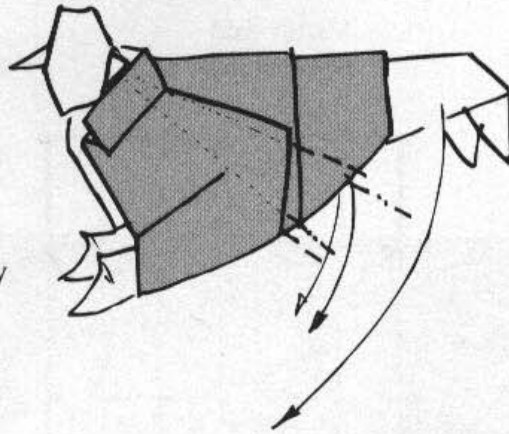

Crimp the legs downwards within the layers of the body

23

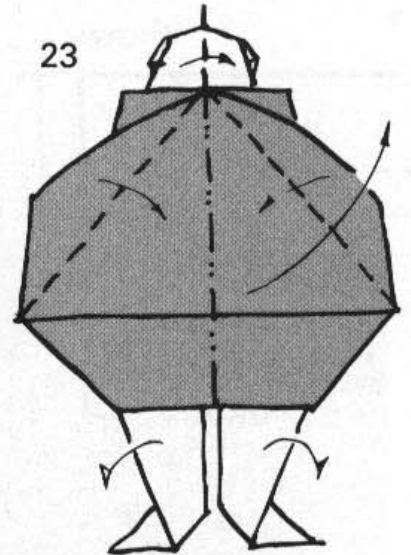

Fold the body in half and lift the head

21



Reposition the hands, and form thumbs with a small crimp

20

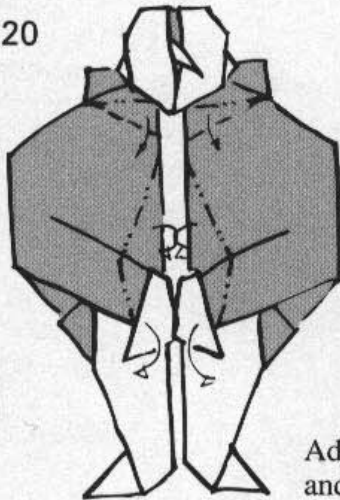

Adjust the collar and lock the arms using the precreased lines

22

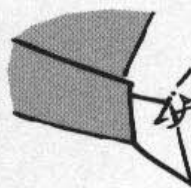

Spelling Book

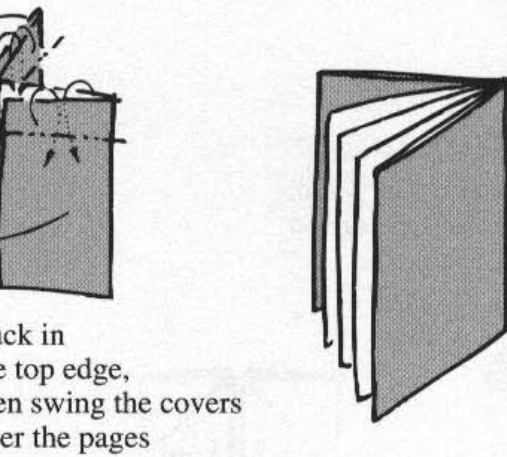
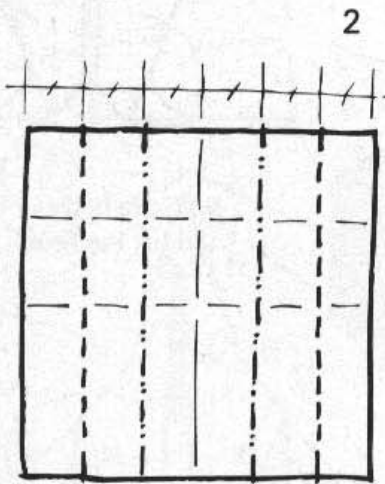
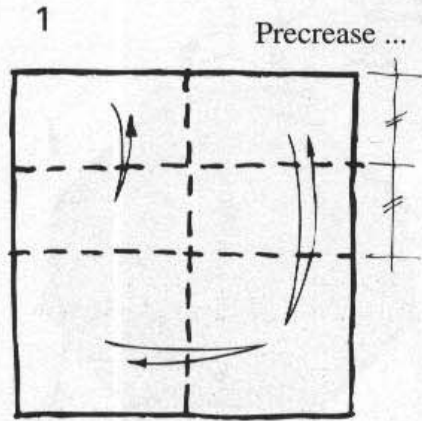

Reverse fold the covers inside

9

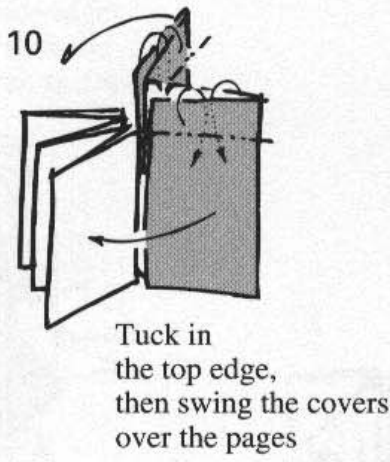

Tuck in the top edge, then swing the covers over the pages

8

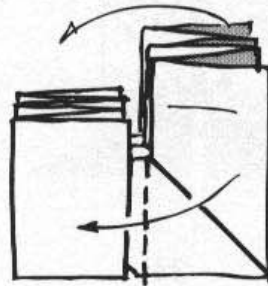

Valley fold front and rear

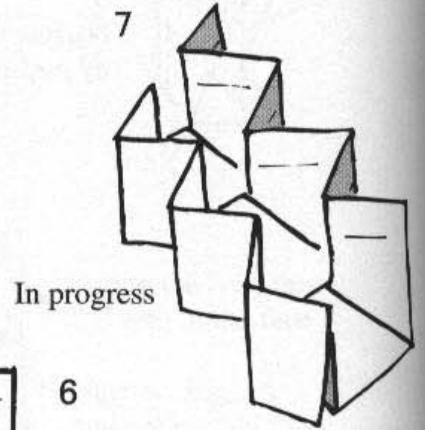

In progress

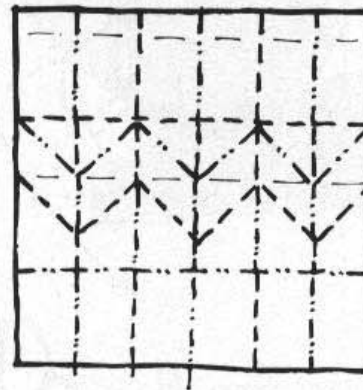
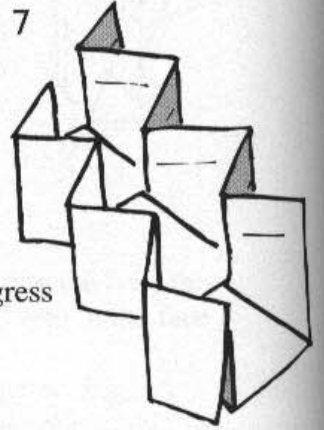

Open up completely, then re-form according to these creases

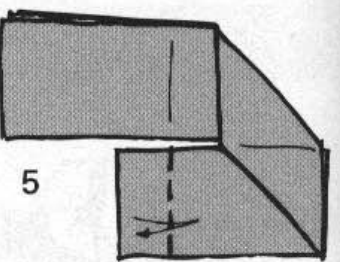

Make a valley fold lining up with the existing crease above

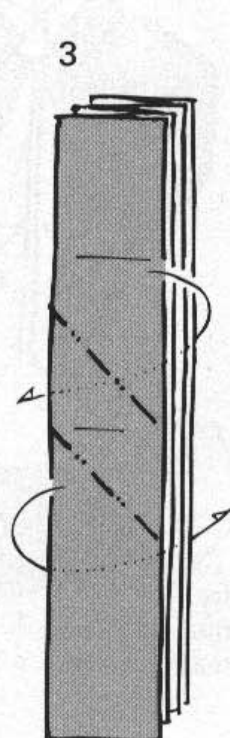

Mountain fold on either side of the centre line

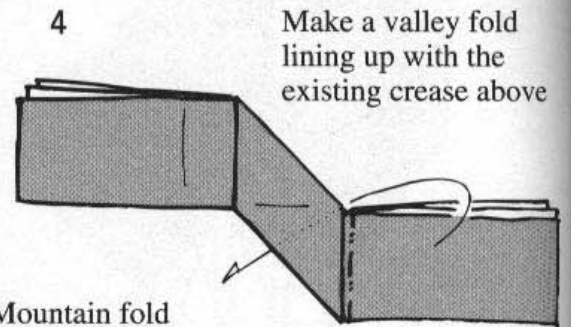

Mountain fold

Groups and Scenes

In this final chapter, I wanted to illustrate examples of collections of models grouped together to form a scene. Since my early attempts at origami, I have enjoyed combining my work collectively in this way. Sometimes the design has been intended to go together with a related fold, other times I have realized that some of the things I had already made complement each other well.

There is a danger in putting designs together, however. It is easy to cover up weaknesses of an individual model by linking it with some logical accompanying model, as if answering a question of identity of either of them: individually they may not be acceptable as completed designs, but collectively they may be. I have tried in these groups never to compromise the strength of the individual design, and my aim has been that it should stand up equally as a completed model in its own right.

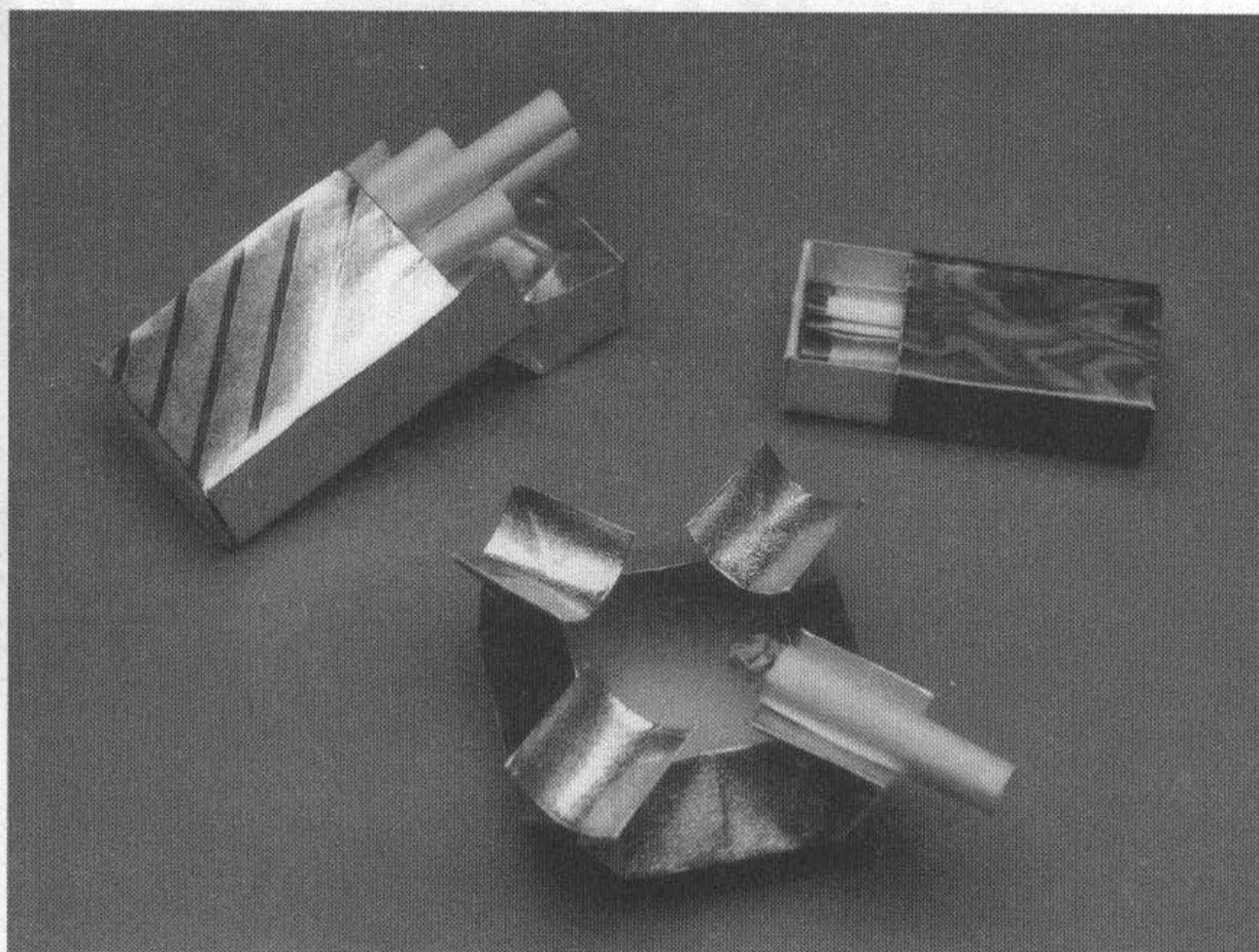

Folding dosen't damage your health...

Cigarette Packet (p. 58), Matchbox (p. 62) and Ashtray (p. 226)

Ashtray

- 1 Precrease into quarters
in both directions
then add 4 more valley folds

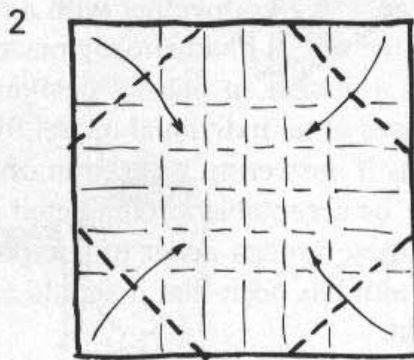
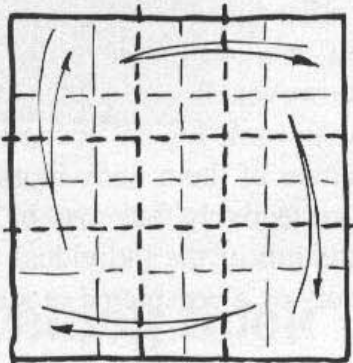

3

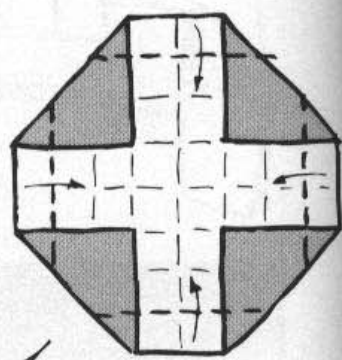

Precrease, then open completely

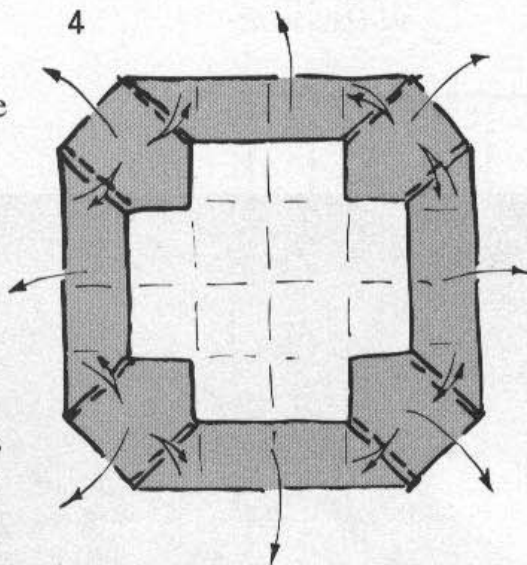

Use this ashtray to add to the cigarette packet (p.58) and the matchbox (p.62) to complete the group which I call "Folding doesn't damage your health". Add an origami cigarette too: I leave the design of this to your imagination!

Precrease 4 valley folds in the centre, then form 4 box-like structures at each corner

5

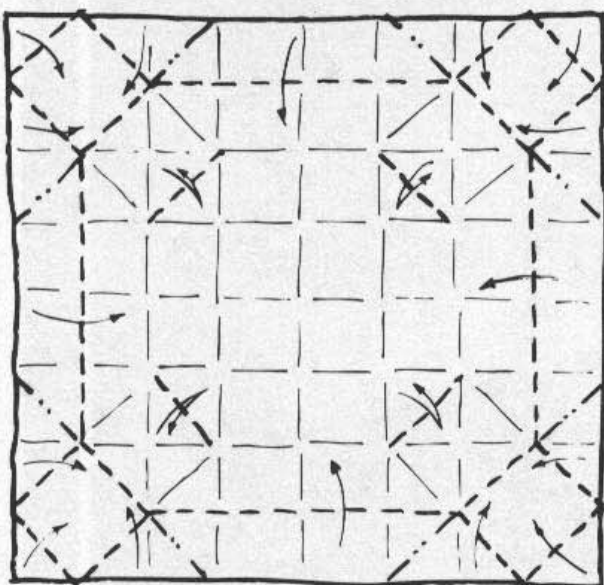

6

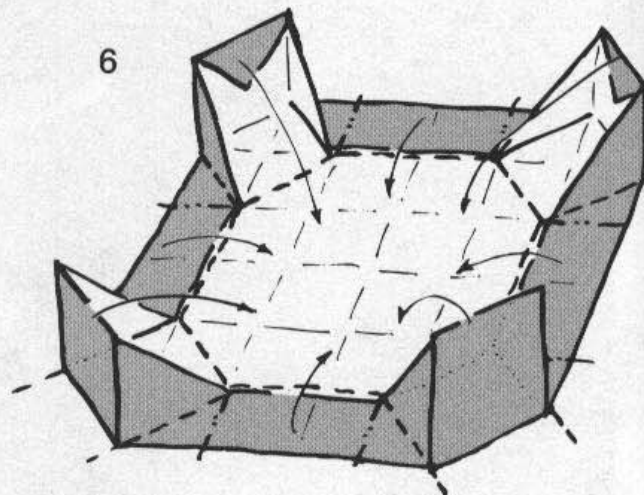

Fold over each corner and the sides as shown

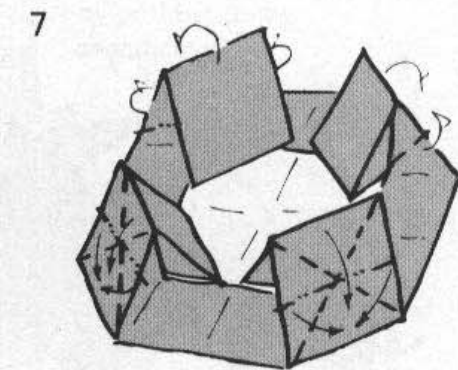
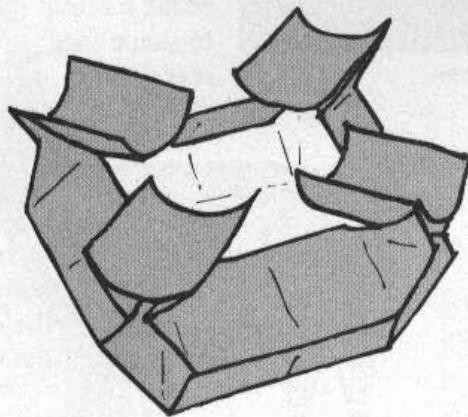
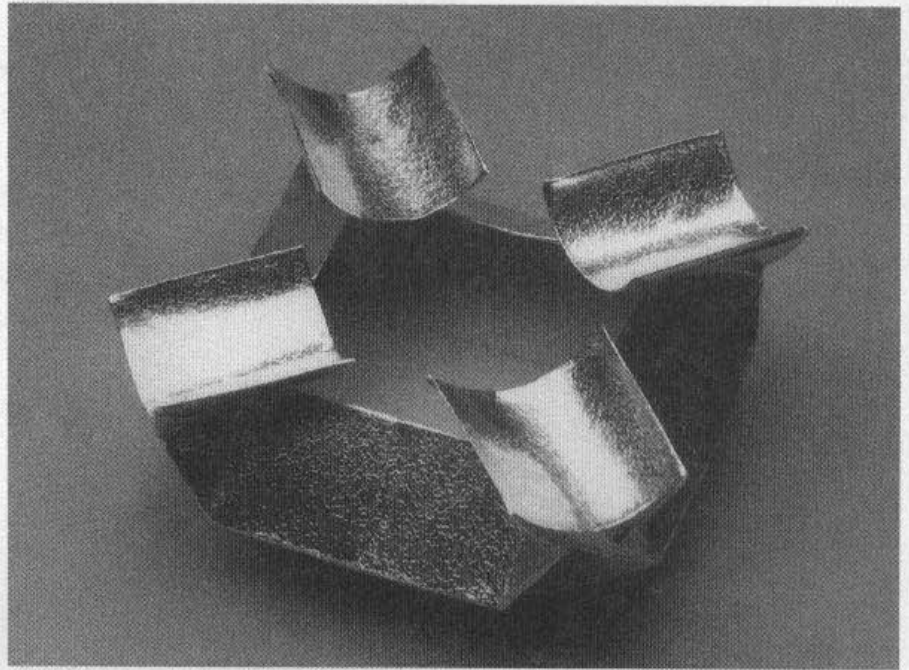

7
Collapse with
waterbomb
base folds

9
Curl the 4 squares
as shown

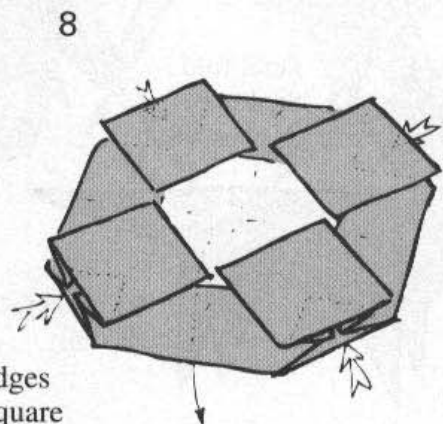
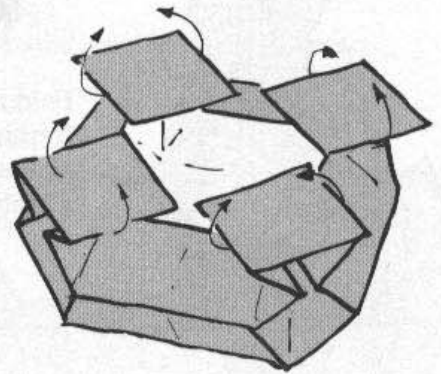

8
Push in the edges
below each square
at the corners to
form to a 3D structure

Reindeer

The Reindeer and the Sleigh on the following pages will complete the Christmas Eve scene of Father Christmas on his rounds. Make some box-like shapes such as traditional waterbombs for the packages on the sleigh.

Start with step 12 of the Fox (p.125)

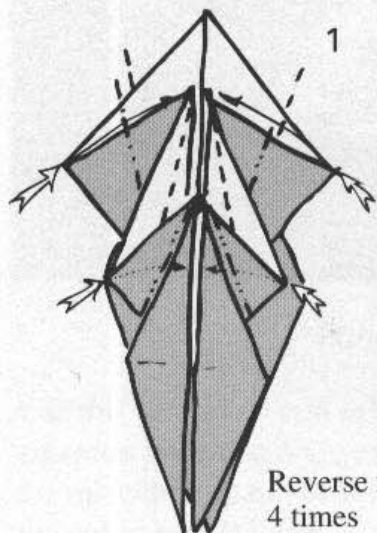

Reverse fold 4 times

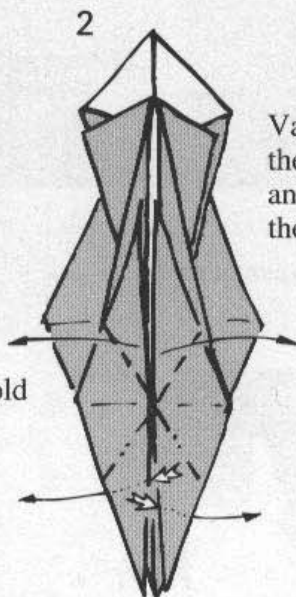

Valley fold the front legs, and reverse fold the rear legs

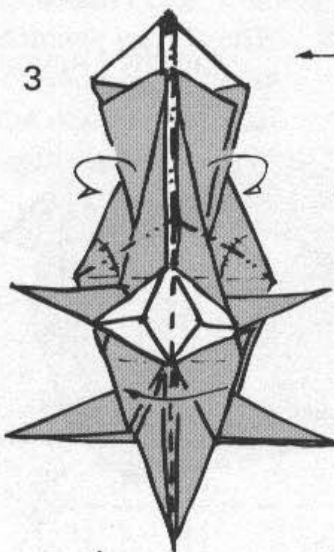

Fold in half, forming the head and neck with a rabbit ear

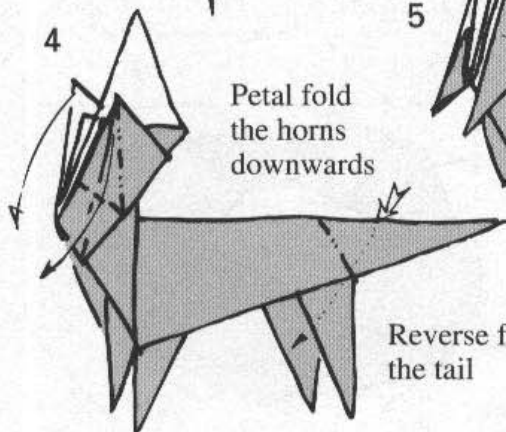

Petal fold the horns downwards

Reverse fold the tail

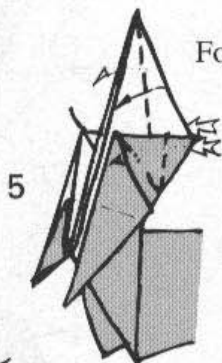

Form the ears



Outside reverse fold the head

Pull back the ears form the mouth with a reverse fold

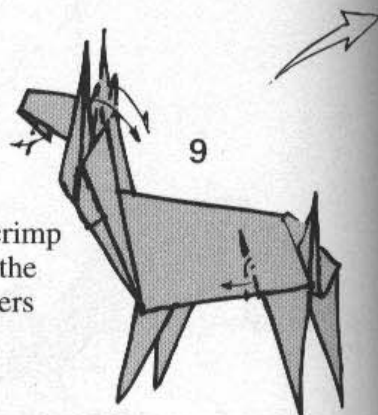

Make a crimp to shape the rear quaters

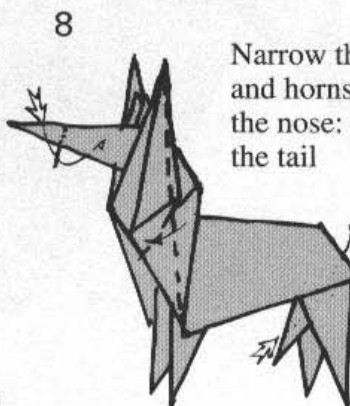

Narrow the neck and horns and blunt the nose: reverse fold the tail

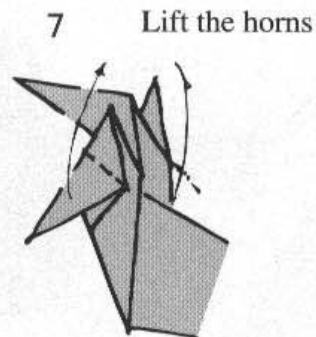

Lift the horns

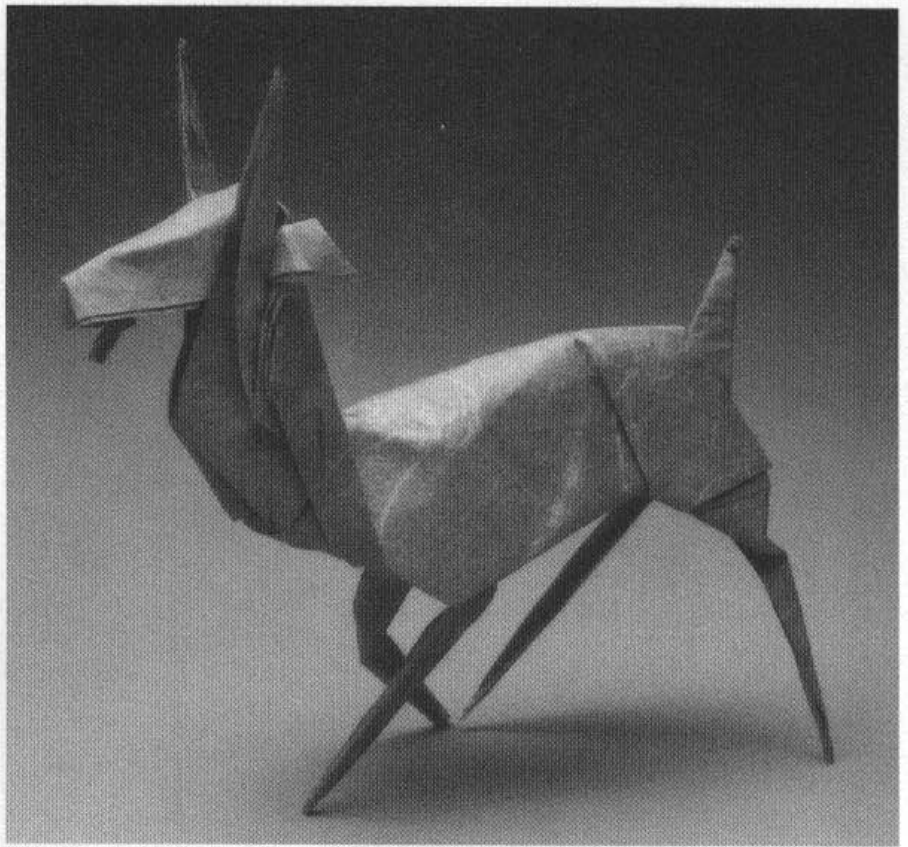

Crimp the head downwards

10

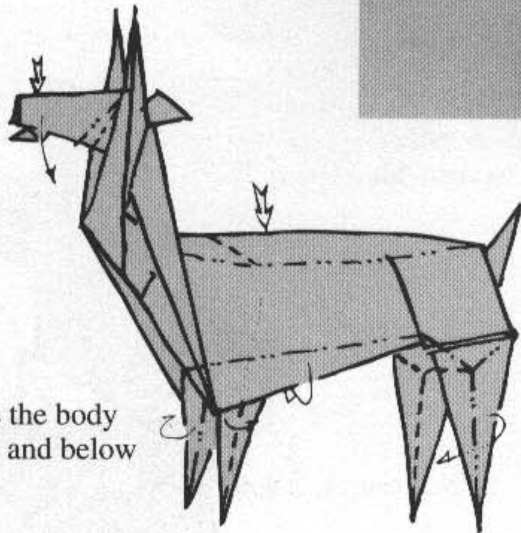

Shape the body
above and below

Narrow the legs
by forming rabbit ears

11

Soften the head
by pushing down
as indicated

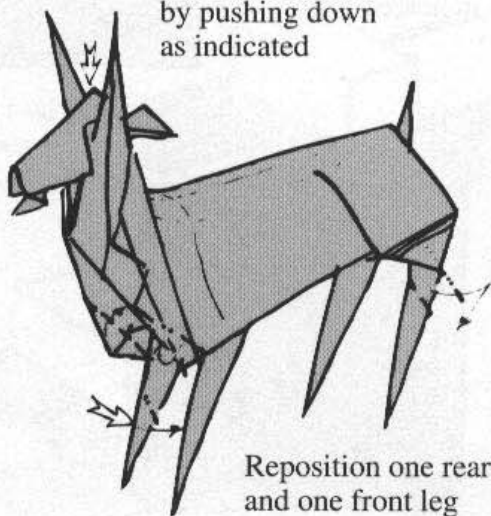

Reposition one rear leg
and one front leg

Tuck the front edges
of the body in
and around the legs

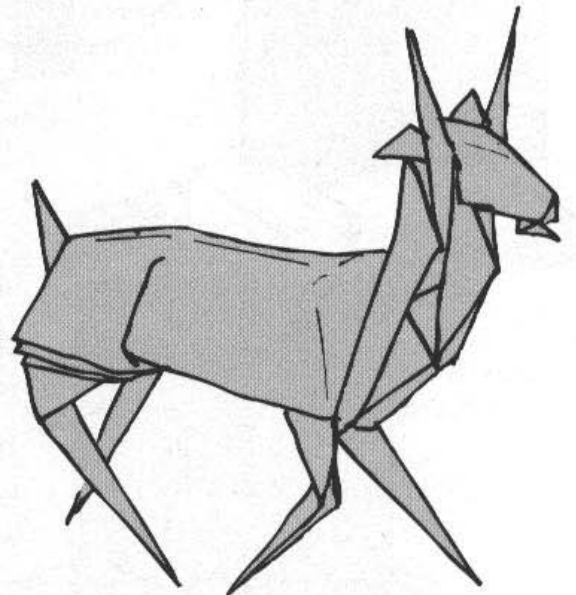

Sleigh

Use a 2x1 rectangle
the same size as for
Father Christmas

Precrease 2 diagonals
at one end of the strip
then valley fold in half

1

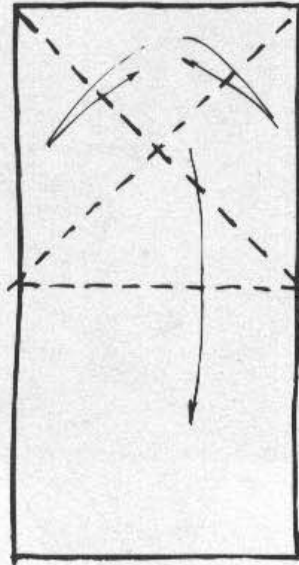

2

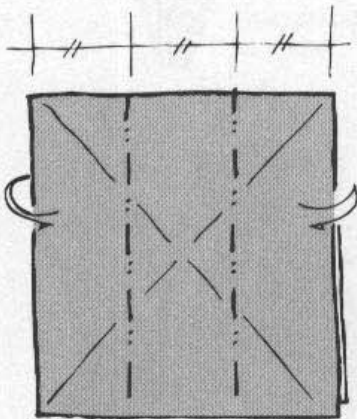

Precrease into 1/3rds
with mountain folds

3

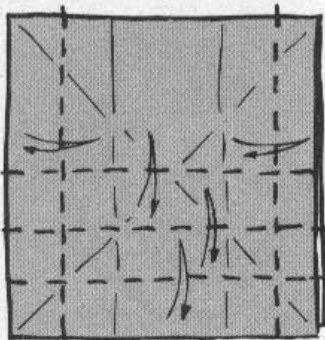

Precrease with valley folds:
the horizontal creases are
on the upper layer only

4

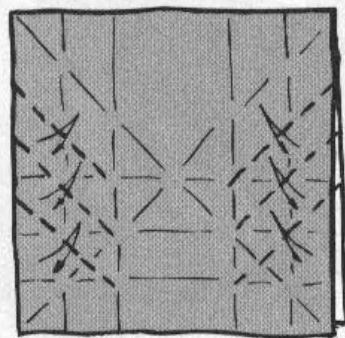

Add 6 diagonals on
the upper layer only

5

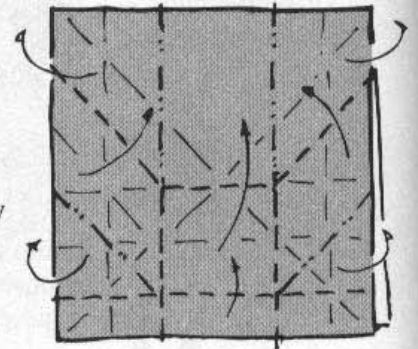

Now form into a 3D
structure, lifting away
the upper layer using
the indicated creases

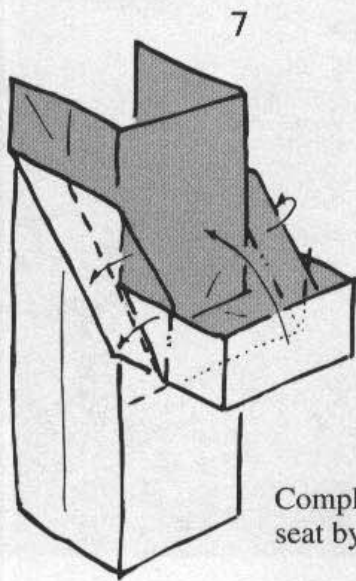

7
Complete the box-section seat by rotating upwards

8
Narrow the sides

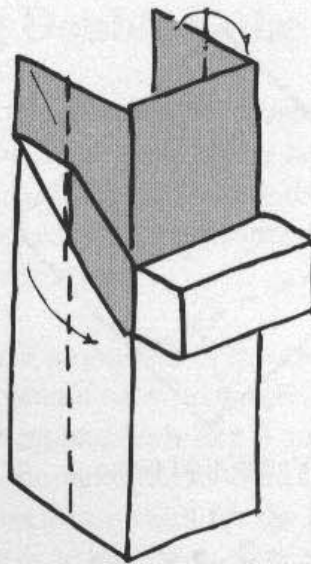

9
Make diagonals to shape the front of the runners and lift the sides

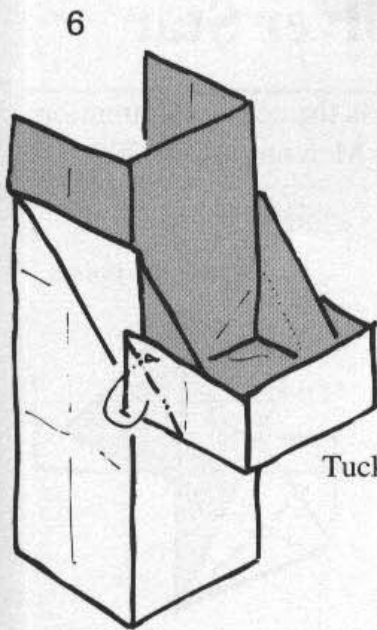
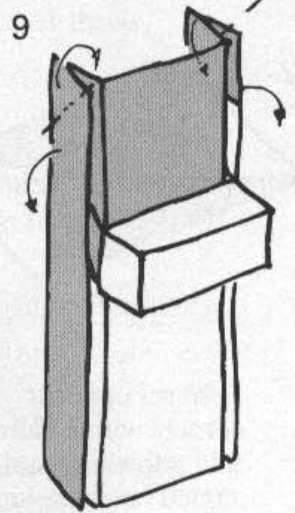

6
Tuck 2 corners behind

10
Valley to shape the front of the sleigh

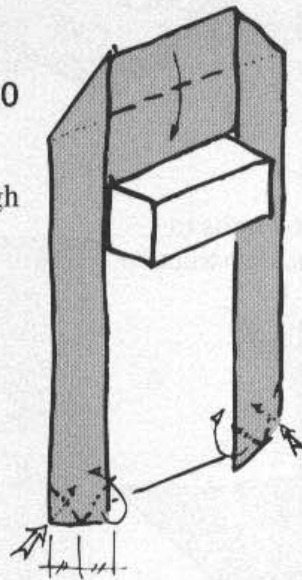

10
Make a point at the end of each runner

11
Tuck the end of the sleigh underneath

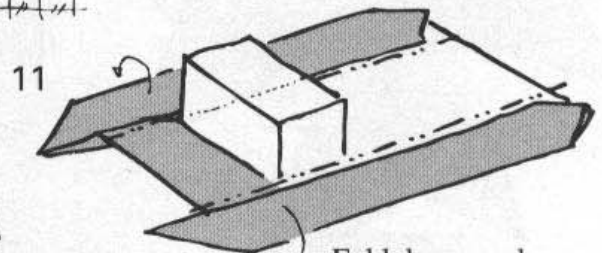

11
Fold down each runner again

12
Reverse fold the footrest

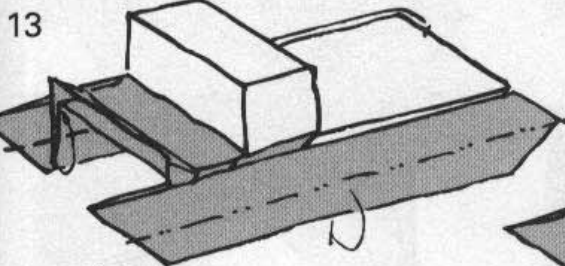
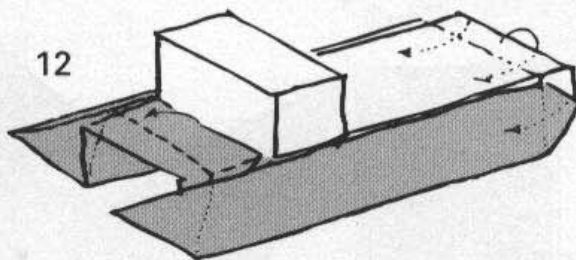

13
Narrow the runners

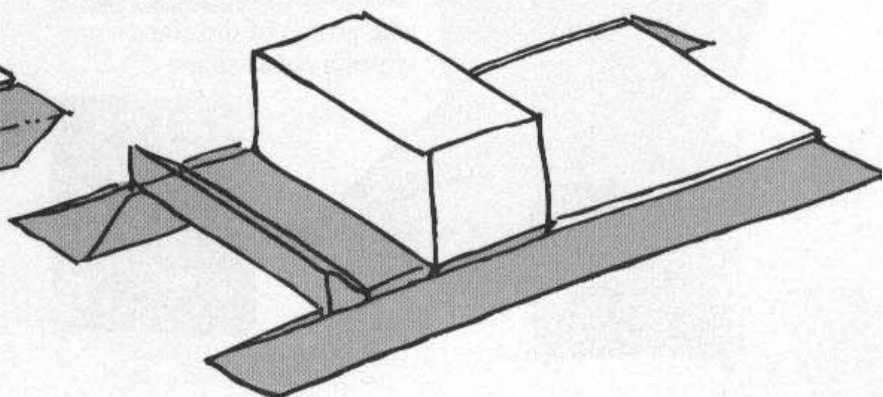

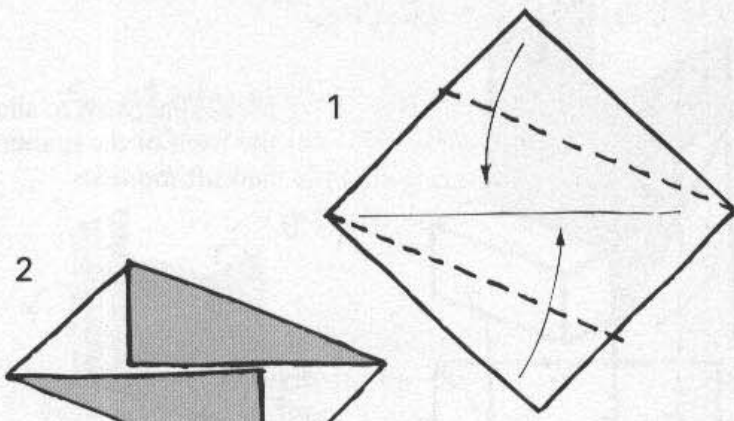

Valley fold twice

Connect opposite corners with a valley fold allowing the right angled corner behind to swing out

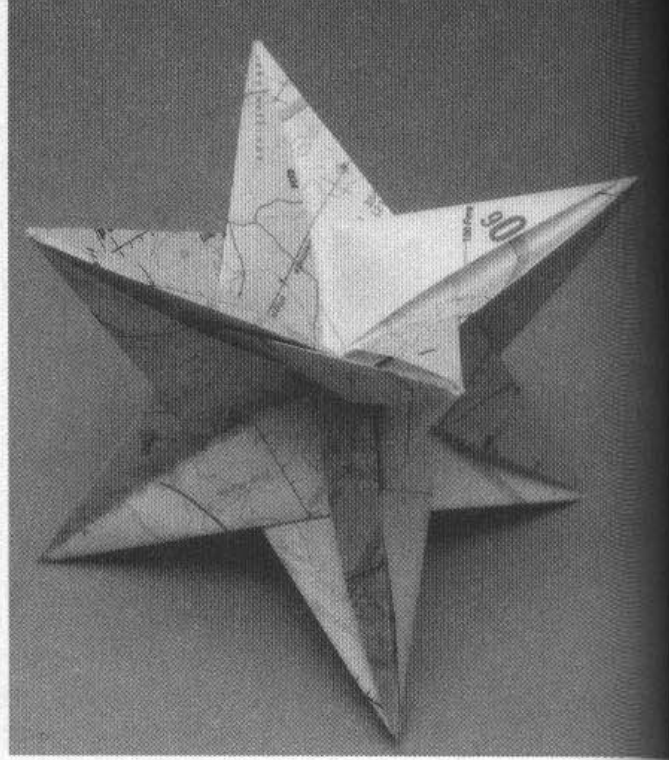
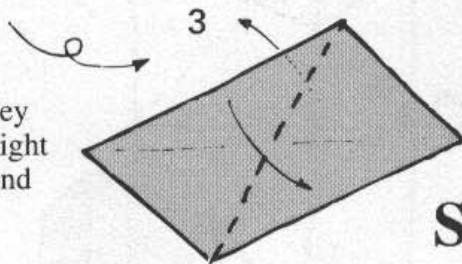

Square Silver Star

This modular star is the centre of attention of the Three Wise Men on pp.204-209.

Connect 4 units to begin the construction

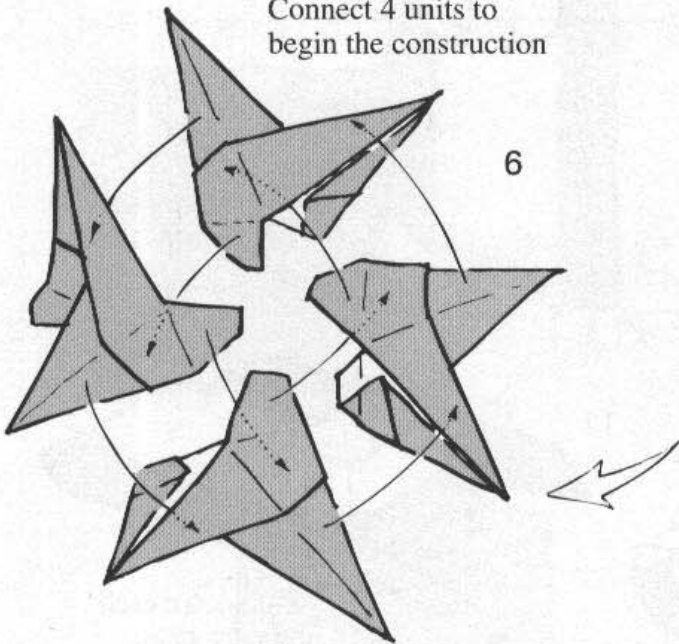

Narrow the points

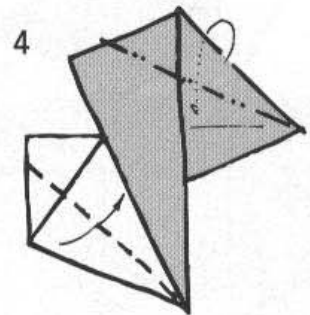
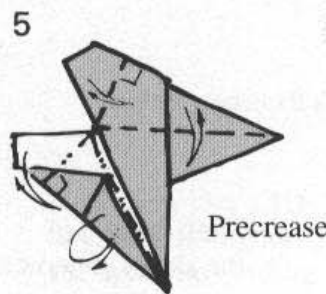

Add 8 more units to finish the star: the points of the star form a cubic shape

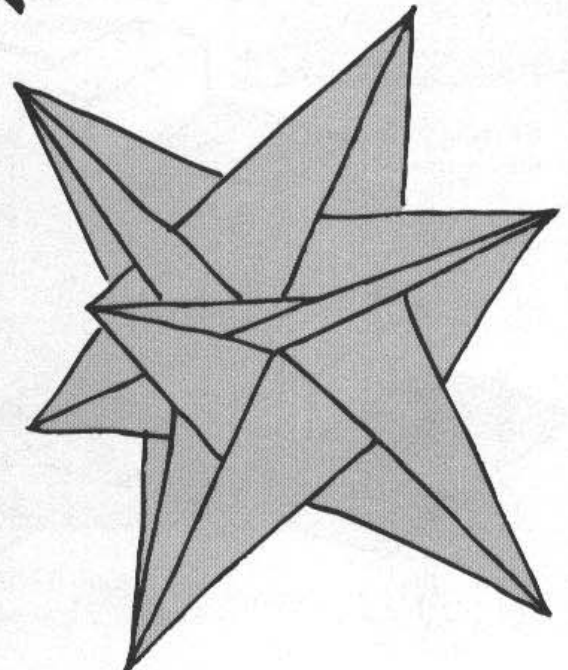
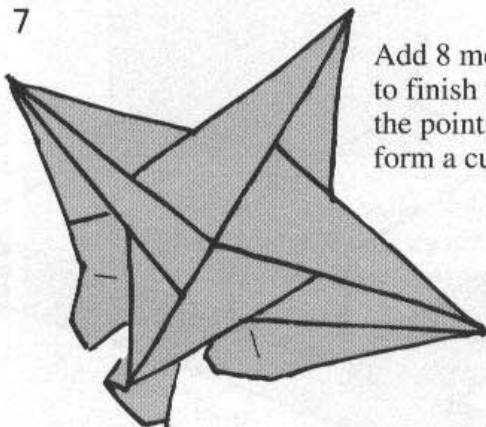

Rotating Double Cube Series

It is possible to adjust the positions of the two cubes of the Venetian Double Cube design by adjusting the size of the starting rectangle. The following drawings give a method of preparing the necessary rectangles for a series of three double cube variations.

You need to cut along one of the creases **a**, **b**, or **c** shown in diagram 3 to obtain each rectangle, and the subsequent drawings correspond with step 4 and iv in the folding sequence for the Venetian Double Cube.

Follow the remaining steps for the basic design to produce the three new double cube variations.

The drawings of the single cube shown on p.234 will enable you to complete a series of double cubes, in which one of the cubes emerges, and then appears to rotate progressively around the other.

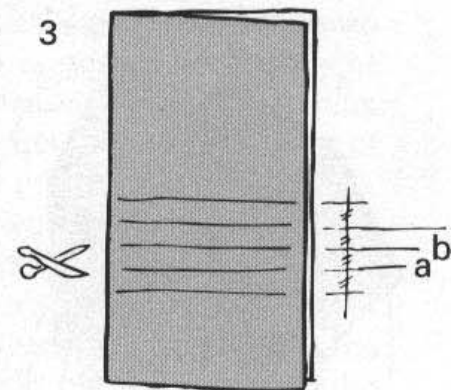
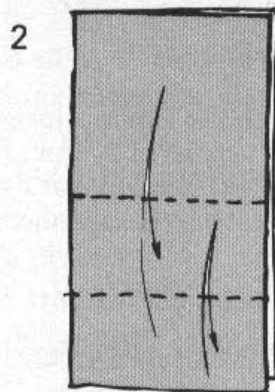
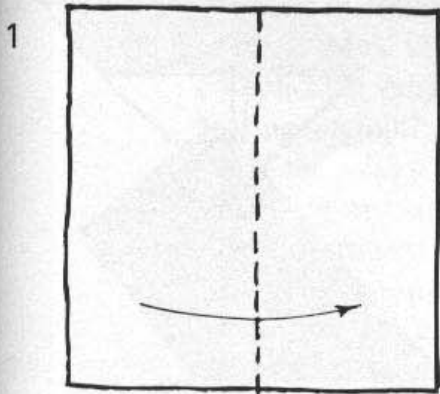

Cut(a)

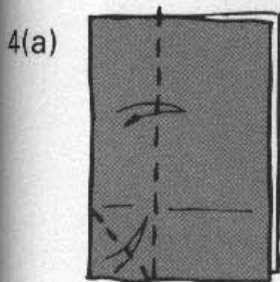

Cut(b)

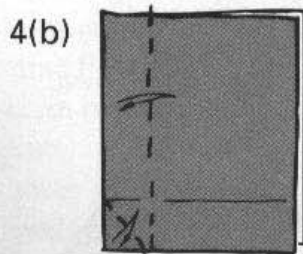

Cut(c)

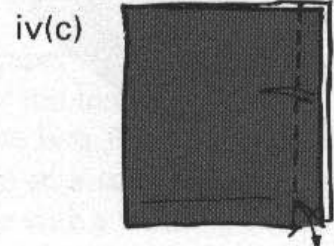
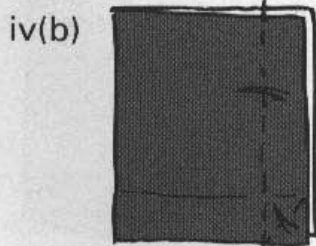
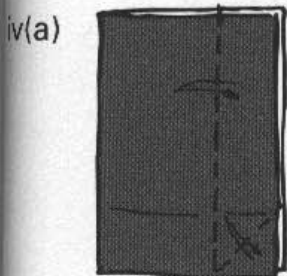
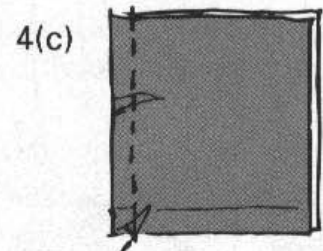

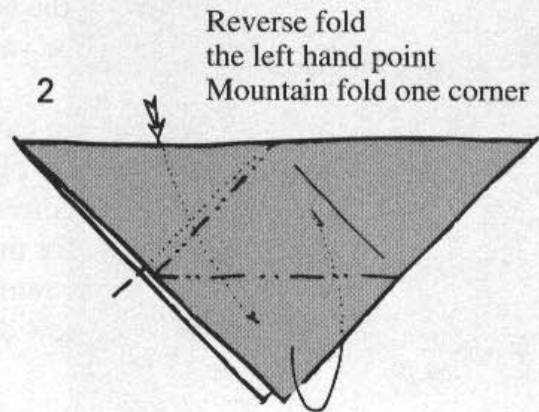
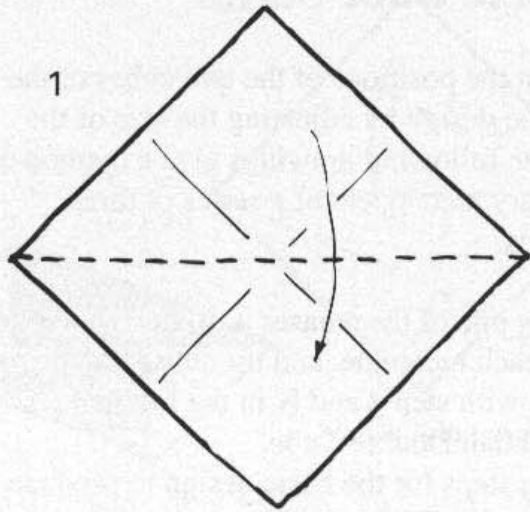

Single Cube

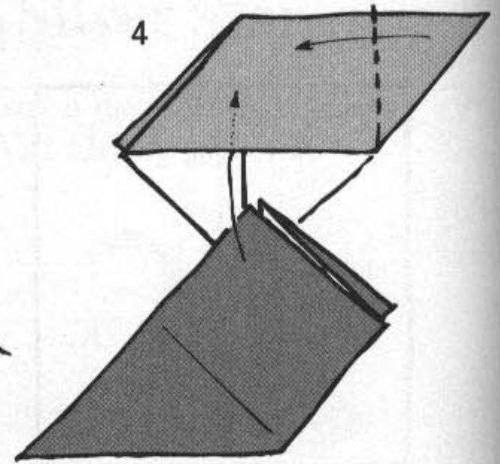
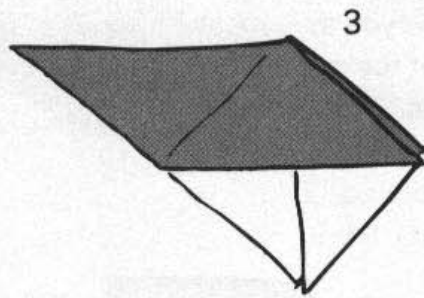

Interlock three units like this, noting the colour arrangement carefully

Make a mirror-image version of 2, turn over and interlock the 2 pieces so they are symmetrical

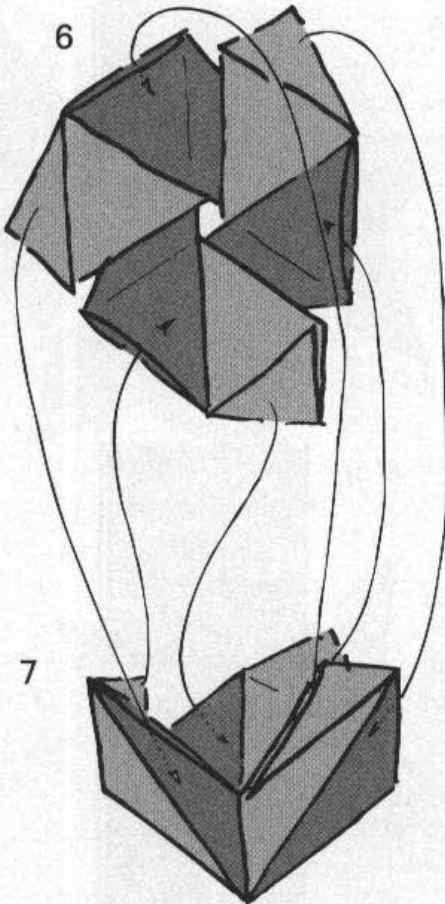

Make another three unit combination, this time having made mountain folds in step 5, and connect the two halves of the cube paying attention to the colours as shown

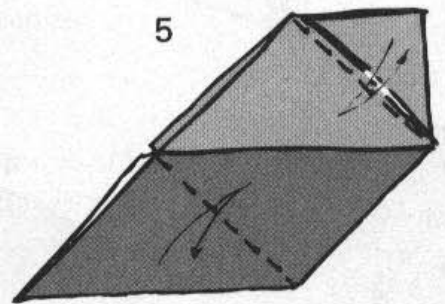

Make 6 two-piece units as above, then precrease

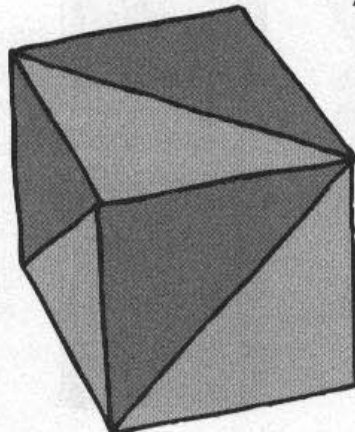

Ideas for Creative Approach

Many origami enthusiasts dismiss the possibility of their being able to originate new designs. I confess that before I made contact with the British Origami Society, I found myself unable to comprehend the method of creating. It seemed to me that in all the designs which I particularly admired there was no relation in the folded stages, or the process, to the finished model, and the paper never seemed to show any likeness to the final stage until the last few steps. The creative process remained very much a mystery, and any success that I thought that I had had was usually an accident.

Meeting my contemporary creators, Max Hulme and Martin Wall, opened many doors for me. I was shown by them that folding a new design was quite a logical process, and analytical thinking was very much a part of creation. When I had folded from books, this was never obvious. Max and Martin rarely folded as I had done, doodling with the paper to see what possibilities could be identified, but had usually started with an idea for a subject, then analyzed its shape. Then they had tried to unfold it in the mind, or to apply a well-known personal formula to describe in folded form the characteristics of the subject which they wanted to portray. Max in particular seemed to have an uncanny ability to fold quite complicated subjects in his mind, then to achieve the result he wanted at the first folding attempt!

For me things were not so easy: I have always had to work long and hard at satisfying my aims. But I think there are ways in which a potential creator can prepare himself. Firstly, it is necessary to build up as wide a vocabulary of folding techniques as possible. This can itself be intensely enjoyable: folding everything one can find from books, and, in my case, from the rich resources of the British Origami Society's library.

I feel it helps to explore traditional techniques, working through all their possibilities, then to store them away in the mind. Maybe at some future date these can be extracted to be used in some new and original way. The inherent geometries of the paper should be respected, and where possible logical and direct folding sequences should be employed. I find it helps to fold quite carelessly at first until a logical result appears, at which time the design can be tidied up and economies employed. Sometimes it helps also to unfold the design in progress, and examine the crease pattern to see if there is a simpler approach or if unnecessary layers can be eliminated. Maybe also a different starting shape can yield a better proportion.

Keep a track on what is going on in the origami world: communicate with your contemporaries or rivals who will no doubt be willing to share ideas or pass comment on what you have done. You should listen to this criticism even if you don't agree with it: sleep on your ideas and your origami problems, and frequently the solution will arrive in the morning (or sometimes even in your dreams!).

As I have already said it doesn't pay to force the paper to do what is unnatural to it and you should not impose yourself on the paper too much. Try cultivate the touch and respect for the medium in the way that the best folders do: avoid the mangled finished result. Sometimes it helps to be given a subject to fold with a tight deadline to meet: "Can you make me a bulldozer with a working shovel by a week next Thursday?!"

The creative aspect of origami is without doubt the most exciting and stimulating one: usually first your creations will make you very proud. It is only with the passage of time as your standards are raised that you may realize that your pride may have been a little misguided. In any case I do hope that the work I have shown you in this book may give you a little inspiration to try to work out some ideas for yourself: I hope that in this way you will receive as much pleasure and fulfillment from origami as I have done.

Contacts

The following English language associations exist to promote the knowledge of origami worldwide, and to put enthusiasts in touch with each other. Periodicals, origami literature and supplies are available from both. I strongly recommend that you make contact, and join. Write to either address for details of the many other origami groups in other countries.

British Origami Society
Penny Groom, Membership Secretary
2a The Chestnuts
Countesthorpe
Leicester
LE8 5TL
England

Origami USA
15 West 77 Street
New York
NY
10024-5192
USA

Bibliography

The following list is a collection of books about origami which I have, over the years, found inspiring. Generally I can recommend any the authors' work as being stimulating and enjoyable. Unfortunately not all these books may still be in print.

Luisa Canovi, Giovanni Ravesi and Dario Uri:

IL LIBRO DEI ROMPICAPO

(The book of Puzzles) Italian Published by Sansoni Editore 1984

Contains a section on modular origami by former CDO president Luisa Canovi.

Peter Engel:

FOLDING THE UNIVERSE ISBN 0-394-75751-3

English

Published by Vintage Books New York 1989

Detailed essays by the author on origami theories, creativity, as well as folding instructions for his own origami designs.

Shuzo Fujimoto:

CREATIVE INVITATION TO ORIGAMI PLAY

Japanese

Published privately 1982

Many black and white photographs of geometric folds, boxes, molecular structures and translucent patterns.

Tomoko Fuse:

UNIT ORIGAMI

Japanese

Published by Chikuma Shobo, Tokyo 1983

UNIT ORIGAMI: Multi dimensional Transformations ISBN 0-87040-852-6

English

Published by Japan Publications, Tokyo 1990

SINGLE SHEET BOXES

ISBN 0-480-87203-5

Japanese

Published by Chikuma Shobo, Tokyo 1992

These three books give examples of the author's styles in modular solids, stars, and boxes in both units and single sheets.

Paul Jackson:

CLASSIC ORIGAMI

ISBN 0-792-45346-8

English

Published by Quintet Publishing Ltd 1992

A collection of memorable designs, both traditional and contemporary.

THE ENCYCLOPAEDIA OF ORIGAMI AND PAPER-CRAFT TECHNIQUES

ISBN 0-7472-0416-0

English

Published by Headline Books 1991

A gallery of photographs of works of art made in a wide cross-section of paper techniques: details of how to make some of these are included.

Kunihiko Kasahara:

VIVA ORIGAMI

ISBN 0-376-83008-2831

Japanese

Published by Sanrio, Tokyo 1982

A detailed collection of the technically-based work of Jun Maekawa

ORIGAMI OMNIBUS

ISBN 0-87040-699-4

English

Published by Japan Publications 1988

A huge book describing the best of the author's origami

Kunihiko Kasahara and Toshie Takahama:

TOP ORIGAMI

ISBN 4-387-85096-5

Japanese

Published by Sanrio, Tokyo 1985

republished in English as:

ORIGAMI FOR THE CONOISSEUR

Published by Japan Publications 1988

ISBN 0-87040-670-1

Modern stimulating designs from around the world

Eric Kenneway:

FOLDING FACES

ISBN 0-448-22557-3

English

Published by Paddington Press 1988

Includes explanations of Kenneway's "rogues gallery" of caricature famous faces.

COMPLETE ORIGAMI

English

Published by Ebury Press 1987

Not only a book of instructions, but also an encyclopaedia of origami history and interesting facts.

Yoshihide Momotani:

ORIGAMI TALES OF OLD JAPAN

Japanese

Published by Seibundo Shinko Sha 1979

How to fold scenes to illustrate traditional Japanese stories.

ORIGAMI IMAGE AND CREATION

ISBN 2072-500202-4202

Japanese

Published by Shogen Sha 1975

The author's origami style thoroughly illustrated.

Samuel Randlett:

THE BEST OF ORIGAMI

English

Published by Faber and Faber 1964

A fine collection of designs from the creative period of the 1960's.

Toshie Takahama:

CREATIVE LIFE WITH CREATIVE ORIGAMI Vol II ISBN 0372-07510-7911

Japanese

Published by Mako Sha 1975

Shows the author's most decorative work, including animal families, Japanese playing cards, and Noshi

Akira Yoshizawa:

ORIGAMI DOKUHON I

ISBN 1072-0030-0952

Japanese

Published by Kamakura Shobo 1969

A classic early book by Yoshizawa explaining his principles for folding animals and natural forms.

CREATIVE ORIGAMI

ISBN 4-14-031028-6

Japanese

Published by NHK 1984

The author's largest book full of superb photographs of his extraordinary work, and many well-described folding instructions.

INDEX

- "A" Rectangles 22, 72, 74, 80, 82
A4 Paper 22
ANIMALS 105
Angle, equal division of 20
ASHTRAY 226
BASIC FORM FOR FIGURES 197
Bestall, Alfred 7
BIBLIOGRAPHY 237
Blintz Bird Base 125, 149
BOAT 200
BOOK 28
BOOK, SPELLING 221
B.O.S. (British Origami Society) 7, 236
 Magazine 36
 Conventions 5, 58, 80
 Library 235
BOTTLE 50
Bowater Scott Calendar 197
BOX AND LID 9, 54
BROOMSTICK 211
BOXES AND CONTAINERS 44
Brown wrapping paper 21, 104
Canson Paper 21, 104
CHRISTMAS TREE FAIRY 15, 183
CIGARETTE PACKET 58
Collier, David 45
 Pentagon of 72
CONTACTS 236
Copier Paper 22
Correia, Jean-Claude 5
COX 201
Crawford, Pat 50
CROWN 187
Cuboctahedron 88
Cundy, H M 72
DIMPLED SILVER DODECAHEDRON 79
Division into equal parts:
 Thirds 64
 Fifths 54
 Sixths 188
 Sevenths 67
DOUBLE CUBE 9, 90
DOUBLE STAR FLEXICUBE 72, 98
DRAGON 172, 214
ELEPHANT 5, 11, 140
Elias Neal 128
EMU 24
Equilateral Triangle, Method of cutting 149
 from rectangle
Escher MC 90
EXHIBITIONIST 26
Fabriano paper 21, 104
FATHER CHRISTMAS 16, 193
FATHER CHRISTMAS AND HIS SACK 191
Folding doesn't damage your health 225
FOX 12, 125
FOXHOUND 12, 123
FOXHUNT 12
Folding living creatures 22
Folding: a permanent trace 5
Folding in the air 21
Fujimoto, Shuzo
 pentangle of 72
 cube of 212
Fuse, Tomoko 44, 47, 71, 76
 Lizard of 71
GEPETTO 14, 216
GIFT BOX 9, 46
GOOSE 114
Gray Alice 30
GROUPS AND SCENES 225
GUINEA PIG 110
HALLOWE'EN WITCH 210
Harbin, Robert 30
HAT 210
HONEYMOON BOX 67
HORSE 11, 168, 214
HORSEMAN 12, 128
Hull, Rod 24
Hulme, Max 7, 235
 matchbox of 58, 64
HUMAN FIGURES 30, 180
IDEAS FOR CREATIVE APPROACH 235
Jackson, Paul 24, 98
Kasahara, Kunihiko
 Icosahedron of 74
 Origami Omnibus 79
 on Human Figures 180
Kawamura, Kenneth 90
Kenneway, Eric
 Origami, Paperfolding for Fun 50, 54
 on Human Figures 180
LAMB AND CORGI 106
Legman, Gershon 123

- Treatise on Blintzes 172
- LION 10, 159
- LION CUB 10, 163
- LIONESSE 10, 150
- MASK 181
- Masu 47
- MATCHBOX 62
- Matisse 5
- Mitchell, David
6 piece Star Puzzle of 98
- MODULAR ORIGAMI 70
- Modular Theories 71
- Momotani, Yoshihide 24, 181
- MOUSE 108
- Nakano, Dokuohtei
Origami Companion by 123
- Neale, Robert 82
Harlequin Mask by 108
- NUT AND BOLT 36
- OARSMAN 198
- Origami: Restrictions and Rules 7, 178
Styles 7
- Origami 4 by R Harbin 30
- Origami Omnibus by K Kasahara 79
- Origami Paperfolding for fun
by E Kenneway 50, 54
- Ow, Francis 72
- OXFORD AND CAMBRIDGE
BOAT RACE 13, 203
- Paper, respect for 8
types of 21
- Pentangle by S Fujimoto 72
- Pentagon by D Collier 72
- PENTAGONAL ENVELOPE 45, 80
- PINOCCHIO 14, 220
- 30-POINT SUNKEN STAR 78
- RABBIT 111
- OAR 200
- Randlett, Samuel 21, 24
Best of Origami by 123
- REINDEER 16, 228
- RHINOCEROS 10, 135
- Rhoads, George
Elephant by 123
- Rhombic Dodecahedron 73
- Rollett, A.P. 72
- Rohm, Fred 128
- ROTATING DOUBLE CUBE SERIES 233
- RULES, TRADITIONAL AND PERSONAL 178
- ST. GEORGE 214
- SEAT AND ROWLOCK 199
- Shen, Philip 179
- SHIELD 215
- SHOWJUMPER 16, 212
- SIGNS AND SYMBOLS 20
- SILVER DODECAHEDRA 80
- THE SILVER RECTANGLE, A SIZE PAPER
& THE $1:\sqrt{2}$ PROPORTION 22
- Silver Rectangle 22, 45
- Simon, Lewis 96
- SINGLE CUBE 234
- SLEIGH 16, 230
- Smith, John 5, 71
"Dave Brill's Horse", poem by, 149
- SPEAR 215
- SPECTACLES 34
- SPELLING BOOK 14, 224
- SPIKY STAR 87
- SQUARE SILVER STAR 232
- SQUARE VERSUS EQUILATERAL
TRIANGLE 149
- SQUIRREL 119
- STELLATED DODECAHEDRON 84
- STAINED GLASS BALLS 85
- SUNKEN SILVER CUBE 74
- SUNKEN SILVER ICOSAHEDRON 75
- SUNKEN SILVER STAR 76
- SYMBOLS AND SUGGESTIONS 21
- TALKING FOX 35
- Thompson, Alan 7
- THOUGHTS ON DIAGRAMMING 43
- THREE WISE MEN 15, 204
- TOYS AND WORKING MODELS 23
- TRUE WOVEN DODECAHEDRON 83
- VENETIAN DOUBLE CUBE 9, 92, 223
- Wall, Martin 7, 235
- WAND 188
- Waterbomb Base 125
- WATERBOMBIC DODECAHEDRON 96
- WET FOLDING TECHNIQUES 104
- Whodunnit Column 36, 191
- WISE MAN I 206
- WISE MAN II 207
- WISE MAN III 209
- WOVEN STRIP DODECAHEDRON 9, 82
- YACHT 52
- Yoshizawa, Akira
symbols pioneered by 21
blintz form box by 47
wet folding by 104
Swan by 115
views on dual models 128
- Zuber Ivo,
Snow White and Seven Dwarves by 35

\$20.00

Cover design by Trella Mendl Design Group Inc.

Brilliant O R I G A M I

His elegant paper-folding style has won him acclaim worldwide. He is David Brill, and he has evolved a unique, multi-cultural approach to origami, blending the "analytical, highly detailed and engineered" approach of the West with the "minimal and artistic" sensibilities of the East. In this profusely illustrated workbook of his designs, David Brill shares his remarkable esthetic as well as his personal philosophy on origami. You'll be inspired by the rich cross-section of his designs. What's more, you need no special tools; detailed, easy-to-follow diagrams provide clear instruction on creating Toys and Models such as: Book, Walking Man and Spectacles; Boxes and Containers including Gift Boxes, a Transparent Bottle, a Money Box and more. Modular origami designs feature Stars, Geometric Balls and the remarkable Double Star Flexicube. Wet-Folding techniques are covered for animals (Lion, Lion Cub and Horse). You'll also find a basic form for human figures which yields Three Wise Men, a Halloween Witch, and a Show Jumper. With his innovative approach to creativity, David Brill will inspire you to seek ideas in all aspects of life and nature and he will help you to cultivate a sensitive touch. Here is your passport to creating...

BRILLIANT ORIGAMI



ABOUT THE AUTHOR

DAVID BRILL has practised origami creatively for twenty years, ever since joining the British Origami Society in 1975. He is also an oil painter, having exhibited at the Royal Academy Summer Exhibitions of 1990 and 1993 in London, and in numerous local exhibitions. The current Chairman of the British Origami Society, Brill has supported the society in other ways, including organizing conventions and administering mail-order functions. He works in a bank in Stockport, Cheshire, and lives nearby in Poynton.

Japan Publications, Inc. Tokyo
Printed in U.S.A.

ISBN 0-87040-896-8



9 780870 408960