

ORIGAMI

Menagerie

21 Challenging Models

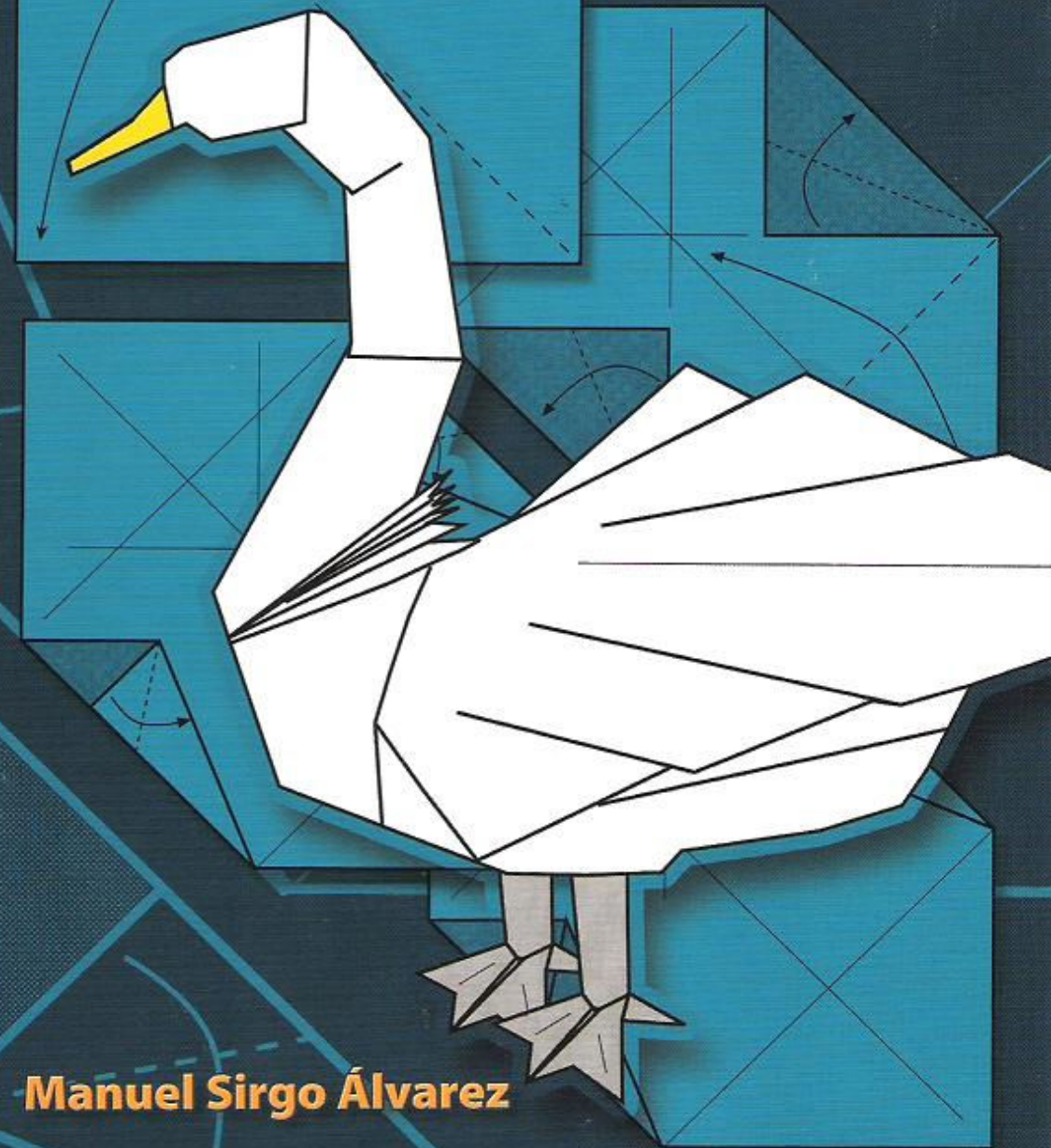
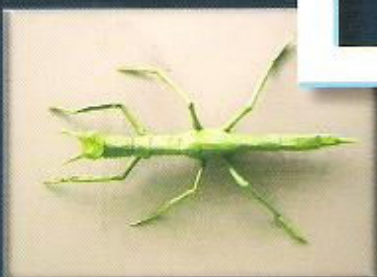

Manuel Sirgo Álvarez

ORIGAMI

Managerie

21 CHALLENGING MODELS

Manuel Sirgo Álvarez

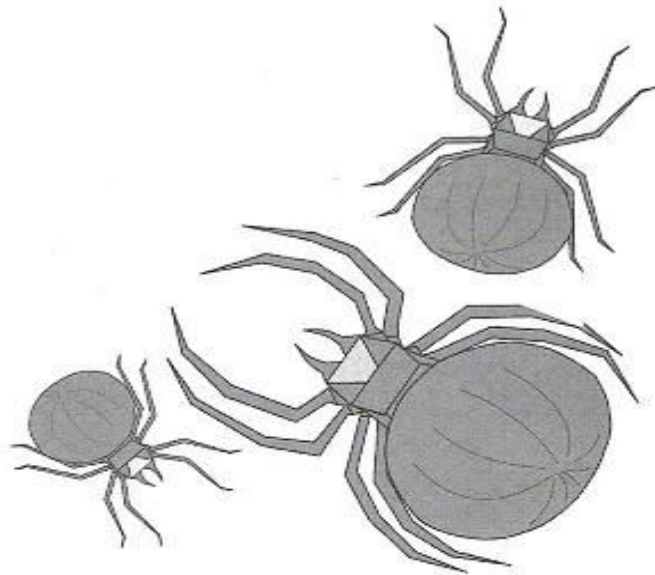

DOVER PUBLICATIONS, INC., MINEOLA, NEW YORK

To Nelly, my wife.

Copyright

Copyright © 2006 by Manuel Sirgo Álvarez
All rights reserved.

Bibliographical Note

This Dover edition, first published in 2008, is a new English translation of *Imaginando en papel*, originally published in Spanish by Editorial Miguel A. Salvatella, S.A., Barcelona, Spain, 2006, and includes all of the original diagrams, illustrations, and photos. This Dover edition is published by special arrangement with Editorial Miguel A. Salvatella, S.A., Calle Santo Domingo 5, 08012 Barcelona, Spain

Library of Congress Cataloging-in-Publication Data

Sirgo Álvarez, Manuel, 1960–
[Imaginando en papel. English]
Origami menagerie : 21 challenging models / Manuel Sirgo Álvarez.
p. cm.
ISBN-13: 978-0-486-46593-7
ISBN-10: 0-486-46593-4
I. Origami. I. Title.
TT870.S52313 2008
736'.982—dc22

2008006619

Manufactured in the United States of America
Dover Publications, Inc., 31 East 2nd Street, Mineola, N.Y. 11501

Foreword

I've known Manuel for some time now and, as in any good friendship, we have shared many different experiences.

We first met over the phone. He called me to ask for a copy of the newsletter in which his first figure, the orb-weaver spider, had been published. Later, we met in Zamora at the AEP convention. The following year, we met again in Santiago, and then in Zaragoza, and the last time we saw each other was at a convention in Barcelona.

After his first origami model was published in *Pajarita*, he created many other models. They were published in several origami newsletters all over the world, but it was his first book that began to open doors for him.

The book and the expositions he organized at each convention allowed people from other countries to see his incredible, ever-increasing collection of original origami creations. In Santiago, he caught the attention of Kamiya; in Seville, that of Hojyo Takashi. Both talked about Manuel while in Japan, writing articles about him for *Origami Tanteidan*, and selecting some of his works for publication in the annual newsletters. Soon after, he received the best accolade of all; he was invited to what is, in my opinion, the best international convention in the world—Italy.

Manuel is an innovator and a real fighter. The word “fear” doesn't exist in his vocabulary. In less than a year, he created 80 figures, making notes about their design in sketches of the figures; these same sketches helped Aníbal Voyer create the drawings for his first book. In Zamora, I was fortunate enough to be able to admire this incredible work and see the selection of figures included in the book. I also saw how Manuel enjoyed collaborating with members of the association. When he agreed to be the newsletter's editor, he didn't know anything about computer design or how to make publication mock-ups, but he knew one thing: “It's all a book.” Soon after, the next edition of the *Pajarita* newsletter came out and nobody even noticed the change in editor.

Some years later, I invited Manuel to come to a gathering of friends in Zaragoza. I was surprised when he accepted. I was able to see another side of him: a happy, dynamic, and talkative person. I also noticed some great improvements in the design of his models; more detailed figures, perfect paper selection, the use of diverse techniques, and improved presentation format. He presented more than 100 designs and there was only one word to describe them: INCREDIBLE! He left everybody at that gathering speechless after seeing the variety of animal origami laid before them: birds, mammals, mythological creatures, and—above all—INSECTS.

Since then, we have kept in close contact and he always tells me about his new creations. He shows me pictures of his models, talks about how he creates the appropriate type of paper for each design, and how he analyzes each square of paper before making his creations. I know he achieved this level of maturity after reading *Origami Design Secrets* by Robert Lang.

After Italy, he promised me he would stop making insect origami and dedicate himself to other types of models; a promise he only partially kept. Manuel became more thoughtful and studious regarding his figures, techniques, and finishing touches. In this book, you'll have the opportunity to see how his design and folding techniques have evolved. Manuel surprises us with 21 superior-level figures—not only of insects, which predominate in the book, but also other figures meant for thicker paper, including some that you can fold using thick wet paper. These include the dugong, narwhal, sea lion, and crocodile with some incredible finishing touches.

This book is a compilation of the results of an intense study of design and folding methodology. You will notice improvements in these two aspects right off, starting with the first figure. Your results will be what we all hope for—INCREDIBLE.





















What surprises me the most about Manuel is that even though he has a wife and kids, in addition to his classes, he still has time to design and even sketch out his models. By the way, I love his sketches. Manuel is inconspicuous and introverted. Many times I have seen him walking alone, paper in hand, in his own world. However, when you truly get to know him, you find that he is a warmhearted, sensitive person.

After having been in the origami world for so many years, I have learned that you can tell how sensitive a person is by watching him or her fold paper. You only need a moment with Manuel to see how sensitive he is and how good he is at what he does.

Thank you, Manuel, for everything you have taught me.

Felipe Moreno

Contents

	Foreword	3
	Contents	5
	Introduction	7
	Folding the Models	9
	Folding Instructions	13
	Meaning of the Symbols	14
	Model Difficulty	17
	Swan swimming	19
	Macaw	27
	Dugong	36
	Narwhal	43
	Sea Lion	46
	Black Widow	51
	Harvestman (<i>Phalangium</i>)	59
	Stingray	63
	Crocodile	76
	Star	91
	Swan	99
	Walking Stick	120
	Stick Insect	128
	Leaf Mantis	136
	Black Ant	150
	Crayfish	165
	Pseudoscorpion	181
	Scorpion (<i>Buthus</i>)	197
	Stag Beetle (<i>Cyclommatus imperator</i>)	202
	European Stag Beetle (<i>Lucanus cervus</i>)	223
	Rhinoceros Beetle flying (<i>Dynastes neptunus</i>)	235

Introduction

Imaginando en Papel [the original Spanish version of *Origami Menagerie*] is my second book of origami figures. As with any book, this book has several objectives. I don't want to be pretentious; I just want to explain how to fold some of my origami figures, without the commitment of a regular publication. I want to draw my figures at my own pace, and at the same time satisfy my origami-folding friends' request made after the publication of my first book *Papiroinsectos*, to continue publishing my figures.

You will also find explanations about folding techniques, finishing touches, and how to prepare the paper for the figures in this book. Every figure you see majestically presented here was folded by Pere Olivella, an expert origami-folder, who made all the figures for this book.

I still don't feel qualified to write about origami design (everything in due time). People often ask me what method I follow to design my models. I usually answer that I can explain how I started, but not how I do it now. When I first started, I used classic bases, paying attention to their points, length, and other aspects, to see what models could come out of them. I would just start with the base and fold and fold until, for better or worse, I had made the figure I set out to make. So, from the "waterbomb" base, I made a turtle, a bear, or an orangutan, each with something in common: four long points and a short point. I remember that, around that time, I asked Anibal Voyer what he thought about this way of starting to learn how to create models. He told me it seemed like a fantastic method, which really motivated me.

Little by little, I started to change my method. First, I would think of a model, then I would work on the base most similar to what I wanted to create. I would modify the base, and from this modified base, would stretch it, double and triple the number of points, etc., and fold the model. To this day, this is the method I use most often, because I'm a little lazy when it comes to creating new bases. I only create one when I have a model that I'm putting a lot of effort into and I don't really have a suitable modifiable base for it. To tell you the truth, what I like the most is the process that goes from the base until the finished model. I let my fingers play with the paper, trying to make the folds the paper itself shows me, in the direction toward which I think it is pointing me. I don't think that the base is insignificant; it just doesn't motivate me that much. I actually use several methods.

This means that, quite often, my use of paper is not optimized—a very trendy technique in modern origami. I'm sorry, but I don't follow mathematical optimization methods. I have designed some models following this technique, which I deeply value when applied by other origami creators, but which I find rather boring when I use it for my own models. Had I focused on applying those design techniques, I'm sure that instead of the more than 200 models I have designed in the last five years, I would have, at most, about one-fifth of that number done by now.

This book features easy, intermediate, advanced, and very advanced models. These categories are very subjective and arbitrary. "Very easy" (Level 1) models are those I believe to be suitable for teaching children. There are none of these in this book. Level 2 is the lowest difficulty level in this book. They are "easy," but require you to know how to fold the following simple bases: kite, fish, bird, frog, and its variants. There are five Level 2 models in this book. There are another five Level 3, or "intermediate," models, for which you must be very familiar with the blintz base, open/closed sink, and color change techniques. There are five models that fall into the "advanced" (Level 4) category. You must be an expert folder, familiar with every kind of base, and able to use every folding technique, no matter how complex it is (unsink, folding an open model, etc.). In Level 5, "Very Advanced," there are six models. The same Level 4 skills are required here, but you will demand more of the paper. For quality folding, you will need special paper and model-finishing techniques.

Some models use the same base and have similar folding sequences. In order not to be repetitive, I have chosen to include one main model and a variation.

I also wish to sincerely thank those who, in one way or another, helped me and motivated me to finish the book. Starting with:

My wife Nelly and my kids, Marta and Victor, who I have spent many hours away from while drawing, but being the origami enthusiasts that they are, have always kept me motivated.

To Pere Olivella Coll, the exceptional origami-folder I mentioned earlier, and winner of several folding contests, who has not only folded all the models in this book, but who also contributed many suggestions for improving the folding sequences and found mistakes in the drawings. His efforts saved me many hours of work and, without his help, this book would have taken a lot longer to finish and see the light of day. Thanks, Pere!

I would also like to thank Felipe Moreno, former AEP president and a magnificent origami folder, who also detected flaws in my models and was there for me when I needed him.

To Alfredo Pérez Jiménez and Juan Pedro Rubio Peña: I thank you both for your suggestions, support, and advice on the “CPs.”

To Nicola Bandoni and Román Díaz, two wonderful designers who have always supported and motivated me.

To Anibal Voyer, for his technical help with model drawing and for all our talks (it is so nice to be able to talk to a genius whenever I want).

To Nicolas Terry, a “magical” creator. In his hands, paper is magically transformed. For his extraordinary efforts over the past four years to selflessly promote my work on his website.

I cannot end these acknowledgements without mentioning Vicente Palacios, to whom I owe so much, both regarding my hobby and my renown in the world of origami. Of course, I would also like to thank Editorial Salvatella, for their patience with deadlines and great publishing work.

I hope you all enjoy this book.

Manuel Sirgo Álvarez, León, March 21, 2006

Folding the Models

It is extremely important to choose the appropriate paper before folding a model. Sandwich paper can be used for most models. “Sandwich paper” is the common name for aluminum foil (like the kind you use in the kitchen), to which tissue paper has been glued on both sides. You may use a glue stick, diluted white glue, diluted latex, adhesive spray, etc. There are several detailed articles on the Internet about this process. You can make the sandwich paper in whatever color you need, or with two colors, and decide how thick the sheet should be by gluing tissue paper to one side only, depending on how flexible you need it to be. I suggest that you get the sandwich paper ready by gluing tissue paper on both sides, so that the foil is not visible when the paper is folded. Besides, it makes the paper less flexible and easier to fold. Folding origami figures with sandwich paper is a very delicate task, but once you get some experience, this is the best kind of paper because it allows you to shape the whole figure in the final steps. When folding sandwich paper, one of the fundamental steps is to smooth out each fold, as if you were trying to erase it.

Another suitable type of paper is foil paper. It is thicker than sandwich paper, but it is still thin enough to allow for easy shaping of the finished model. There are several resources for getting foil paper in the color you want. This paper is sold in rolls and one side is a metallic, available in various colors, and the other is white. You can glue tissue paper to foil paper, as with sandwich paper, which will make it thicker and a little less flexible. Another option, which I frequently use, is to paint the white side with a tempera-based paint mixed with latex and diluted with water. The latex gives it a satin-like texture and ensures that the tempera does not crumble during folding. The amount of water used will depend on how thick you want the paint to be. The less water there is, the more solid and thick the color will be. The more water you use, the more diluted the color will be, and the easier it will be to spread on the paper and without increasing the paper’s final thickness much. There is a product called AQUALUX, made by Titán, which is a mix of tempera and latex, which I apply directly to the paper using a small paint roller so that the result is more uniform.

Foil paper that is prepared this way does not tear as easily as the untreated kind. Just like with sandwich paper, you must smooth out each fold. In both cases, I use my fingernail to mark all folds, since the stronger the mark, the easier it is to fold. To make sink folds easier, the best method is to mark the valley fold, smooth it out, make the mountain fold, and smooth it out. This way, the sink fold will be easier.

Several models in this book can be folded perfectly well with the wet technique. To do this, you must use paper that contains glue. When wet, this kind of paper becomes soft and can be easily folded. You’ll need to use tweezers or other tools to submerge the paper so that it keeps the desired shape. Once the paper is dry, the model will be perfectly rigid and keep the desired shape. The most suitable kinds of paper are Canson Miteintes (160 g) and Ingres (100 g). There are several detailed articles available on the Internet about this technique.

Craft paper is another possibility. There are a great variety of textures, thicknesses, and colors, although the color options are a lot more limited than those for tissue paper. These are hard to find; they are only available in some stores and the variety is limited. Another option is to buy paper online, even though it is expensive and distributors often require a minimum amount per order that is more than most people need.

There are several advantages to using craft paper: it has a more pleasant and realistic texture, it creates long-lasting models that will stand the test of time, and it is easier to use to make complex folds, such as

sinks, which can be done without any preparation. There are some downfalls as well, because it is hard to make craft paper bi-colored. Maybe the easiest way is using adhesive spray and gluing tissue paper or another craft paper to it—the latter may make the paper extremely thick and unfit for more complex models. Another inconvenience is that they are hard to mold and don't hold their shape. In most cases, folds open easily, so you'll need to use a finish like methylcellulose after the wet-paper technique.

Among the craft paper types I have tried, the one made of banana fiber yields the best results. It holds folds well, without the aid of any product, although the finished results are better if you do use one. Lokta paper varies from very thin to fairly thick. In both cases, methylcellulose will be needed for the final touches.

Methylcellulose is the glue used to hang wallpaper. It is sold in powder form and must be diluted according to the manufacturer's instructions. I like using a thicker, almost gelatin-like mix, because it does not saturate the paper as much or deform the treated area, and it dries faster. Depending on the model I am folding, I apply methylcellulose during the folding process, or use it exclusively at the end. It is important to apply it in one or a few places and let it dry before applying it in other areas. For that area to have the exact shape we want, we will need to use clothespins or other tools to hold the model. If I apply methylcellulose to an insect model, for example, I will first shape it and then harden the exoskeleton, followed by the head, antennas, and, finally, the legs. If I were to start with the legs, upon shaping the exoskeleton, the orientation of the legs might no longer be correct, and I would have to redo them.

The advantage of using methylcellulose is that it hardens the paper without gluing it, so if the result is not what you had in mind, you can moisten it a bit and change the shape. It is a slow process that requires several days to complete. Another advantage is that it makes the paper thinner, which helps you make thin, but hard legs.

Methylcellulose helps with putting the finishes touches on a model, but it does not make miracles. You must fold a model well and make precise folds to get a good result. In this book, you'll also learn about other kinds of paper you can use.

Here are some small tips, hints, and guidelines for folding the models shown in this book:

Level 2 models are fairly accessible to beginners. By Level 3, the figures are harder and will demand more attention to folding precision. This doesn't mean that easier models allow for a lack of precision, it is just that they are more forgiving.

Foil paper, even 5.9 x 5.9 inches (15 x 15 cm) pieces, is perfectly suitable for Level 3 models. However, the models will be easier to fold using sandwich paper. The Crocodile allows—almost demands—thicker paper. If you are making a large version of the model, you can use Canson paper. This thicker paper should be craft-style paper, like thick Lokta or even Batik (although the latter requires a great amount of effort due to volume of the layers), and calls for the use of methylcellulose and moistening of the areas that require shaping.

For Levels 4 and 5, folding precision is crucial. Sandwich paper or thinner craft paper, like thin Lokta, banana fiber paper, treated tissue paper, etc., are the most suitable kinds.

The Macaw can be folded with any kind of paper, in any size up to 5.9 x 5.9 inches (15 x 15 cm). It is a great model to hold on your finger, like a pet.

The swimming Swan needs more flexible paper, such as foil or sandwich paper, which allows you to give it a nice shape and greater elegance.

For better results and a satin-like finish, I cover the white side of a sheet of foil paper with diluted latex, even though it is not necessary. On the foil side, I glue some black tissue paper. The Sea Lion, Dugong, and Narwhal must be folded with flexible foil paper, or thicker paper following the wet technique, so you can give them more volume and a better appearance. Sandwich paper is not recommended, because the finished model would be too flimsy. These models are not difficult and are very rewarding.

I used foil paper for the Narwhal, gluing dark tissue paper on the foil side and leaving the white side untreated to easily get the right color and shape of the horn. I use thick Lokta paper with methylcellulose finishing for the Sea Lion and Dugong, shaping the neck and face with the help of tweezers, so that these areas would dry correctly.

The Black Widow and Harvestman (*Phalangium*) have the same base, but have different final steps. Sandwich and foil paper, which allow for easy final shaping, are perfectly suitable for these models.

The Crocodile and the “Eagle ray” or Stingray can be folded using a great variety of paper, including some thick ones. I have folded both models using Lokta paper. The Crocodile would have been better with a more rigid paper, such as Ingres, to make step 114 easier.

I don't have many tips for Levels 4 and 5. As I said before, paper selection is crucial for these models and folding precision makes a large difference between just finishing the model and getting a great final result.

The Walking Stick and Black Ant will turn out perfectly if you follow the folding process. As for the Walking Stick, the best effect is achieved by carefully following step 86, when you make the model completely round and force the legs a little bit to put them in the right place. The Leaf Mantis requires careful final shaping to achieve the best effect. I suggest that you look at pictures of Manuel Sirgo's finished model.





















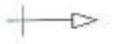

On your first attempt at folding the Crayfish, you must use a large piece of paper—larger than 11.8 x 11.8 inches (30 x 30 cm), at least 19.7 x 19.7 inches (50 x 50 cm). This model, along with the Pseudoscorpion and Scorpion (*Buthus*), requires some final shaping to get a good finished result.

The European Stag Beetle (*Lucanus cervus*) and Stag Beetle (*Cyclommatus imperator*) models require steps that easily lead you to the finished result; only a little shaping of the abdomen is needed.

The flying Rhinoceros Beetle (*Dynastes neptunus*) is the most complex model in the book. You must pay special attention to step 75, carefully follow all the instructions, and complete intermediate steps 76 and 77 to obtain an error-free model.

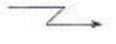
Pere Olivella

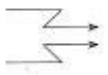
Folding Instructions

	<i>Valley Fold</i>		<i>Sink, Flatten</i>
	<i>Mountain Fold</i>		<i>Turn the Model Over</i>
	<i>X-ray View</i>		<i>Rotate the Model</i>
	<i>Mark</i>		<i>Enlarged View</i>
	<i>Fold Forward</i>		<i>Reduced View</i>
	<i>Fold Backward</i>		<i>Hold By</i>
	<i>Fold Inward</i>		<i>Stretch</i>
	<i>Repeat</i>		<i>Color Facing Down</i>
	<i>Fold and Unfold</i>		<i>Color Facing Up</i>
	<i>Accordion Fold</i>		<i>Same Color on Both Sides</i>
	<i>Accordion Sink</i>		
	<i>Open up</i>		

Meaning of the Symbols

Next, a few of the symbol meanings will be explained for the beginners.

Valley fold

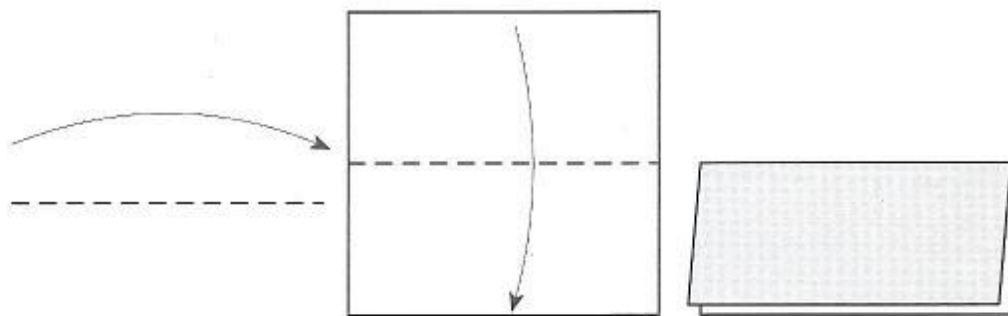

A valley fold is represented by a dashed line and an arrow with a symmetrical head, which indicate the direction the paper should be folded. In this example, the paper is folded in half; the top half is folded so that it rests on the bottom half.

Mountain fold

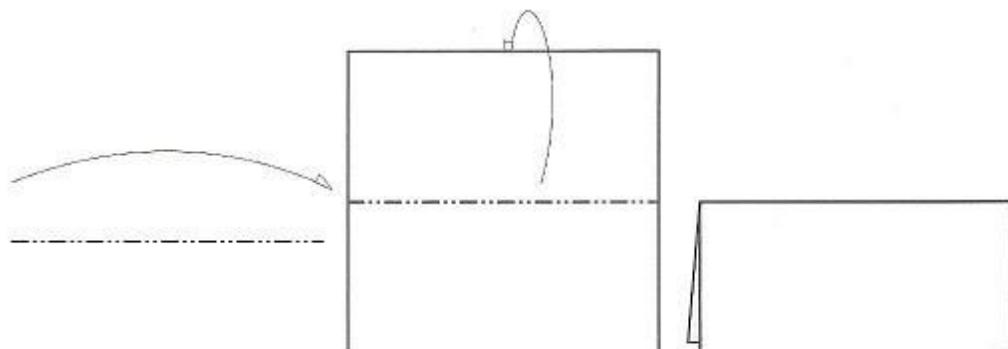

A dashed and dotted line and an arrow with an asymmetrical head indicate the direction in which the paper should be folded. Usually, when this type of arrow is used, the paper should be folded away from you, exactly the opposite of a valley fold.

Fold and unfold

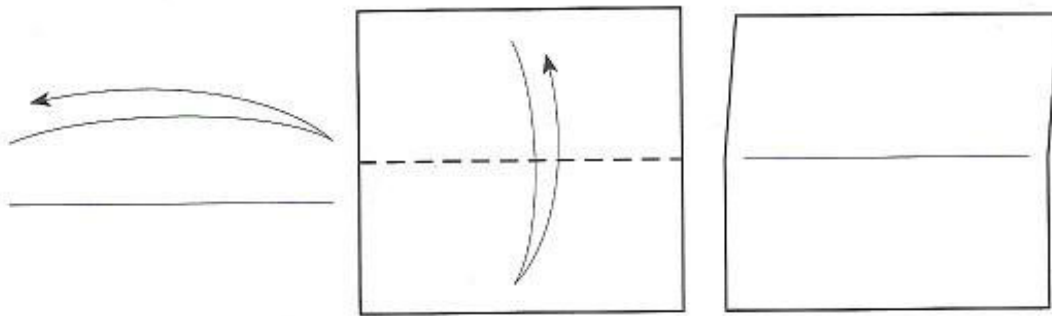

This symbol indicates that we should make a valley fold and then unfold it, going back to the original position. The only change will be a mark where the paper was folded.

Accordion fold

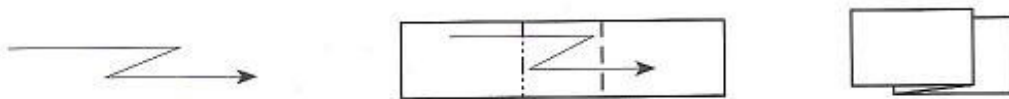

This fold consists of a valley fold followed by a mountain fold. The arrow, as usual, indicates the direction in which the paper should be folded and the zigzag line shows what the end result will look like when viewed from the side.

Fold over and over

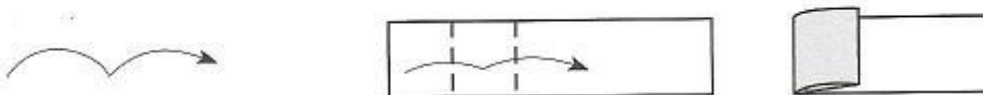

This process involves making two or more consecutive folds on the same side. They can be either valley or mountain folds; the process is the same.

Sink

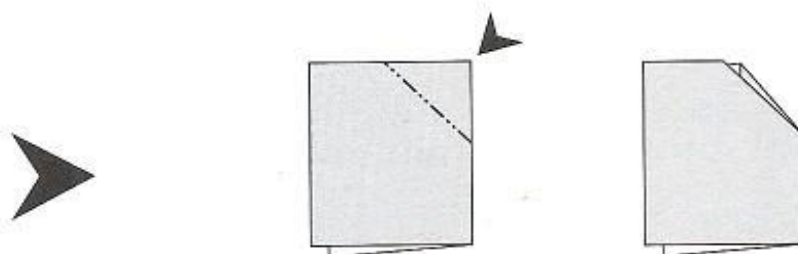

This fold is achieved by pushing a point inward to “sink” it. The model should still be flat after this fold is completed.

Rotate



This process involves rotating the model in the direction indicated by the arrows. The rotation angle is written inside the symbol.

Turn over



The symbol is composed of an arrow with a loop in the tail, which indicates that we should turn the paper over, putting the side that was facing up, down on the table.

Enlarged view



This indicates that the next step has been drawn on a larger scale, so that it can be more easily understood.

Reduced view



This arrow is often used after showing an enlarged detailed view. After folding this area, we redraw the model on a smaller scale.

Repeat

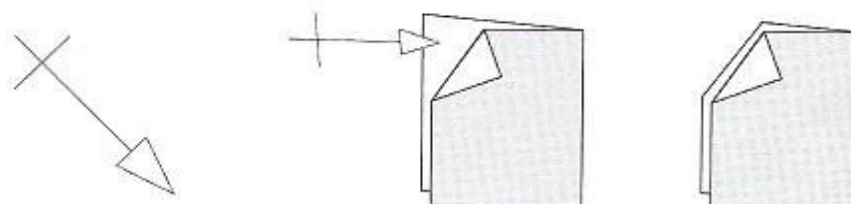

This symbol indicates where and how many times you should repeat the previous steps (as many times as the number of dashes on the arrow.)

Model Difficulty

The difficulty levels are as follows:

Level 1: Beginners who have mastered the following: kite and fish bases, mountain folds, valley folds, hood folds, and preliminary and waterbomb bases.

Level 2: Beginners who have mastered the following bases: kite, fish, bird, and frog. Basic folds, with the exception of unsink.

Level 3: Intermediate folders who have mastered all the bases, including the blintz frog, and every type of fold.

Level 4: Advanced folders who have mastered models that have many steps and some open models.

Level 5: Advanced folders who have mastered models that require particularly thin paper or have a large number of steps.

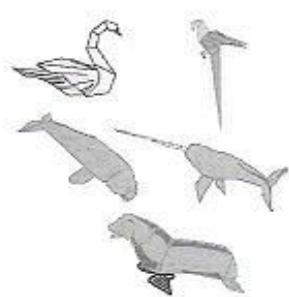

LEVEL 2

Swan swimming
Macaw
Dugong
Narwhal
Sea Lion



LEVEL 3

Black Widow
Harvestman
Stingray
Crocodile
Star

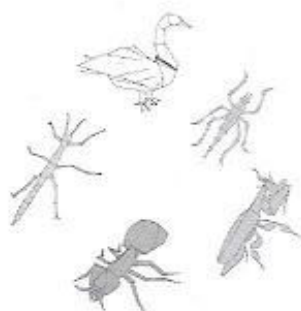

LEVEL 4

Swan
Walking Stick
Stick Insect
Leaf Mantis
Black Ant

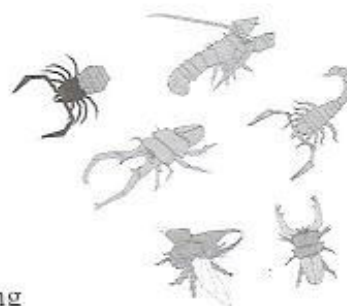

LEVEL 5

Crayfish
Pseudoscorpion
Scorpion
Stag Beetle
European Stag Beetle
Rhinoceros Beetle flying

Swan swimming

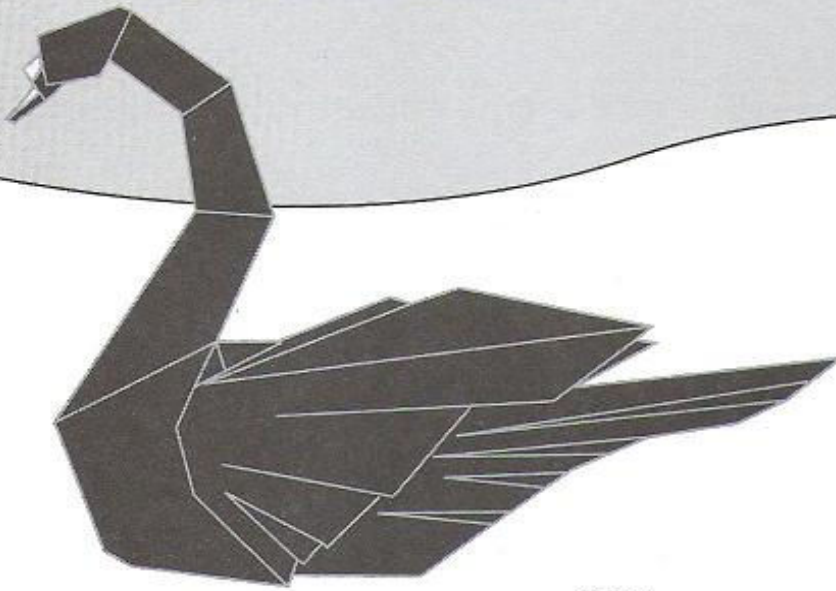
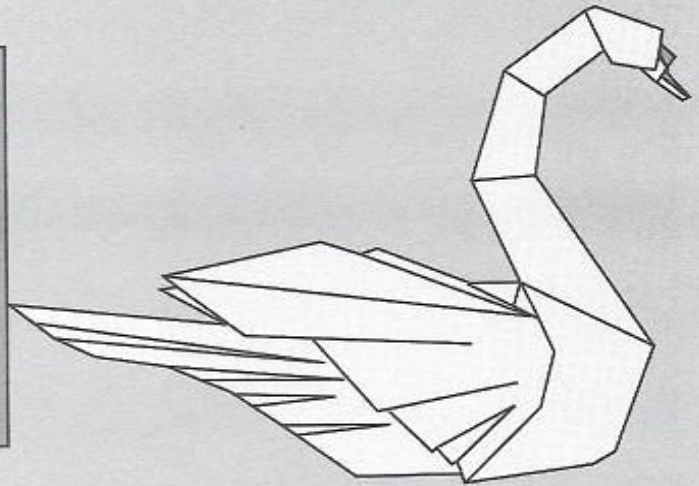

The paper should be white and orange for a white swan with the orange beak or black paper and red for a black swan with the beak red.

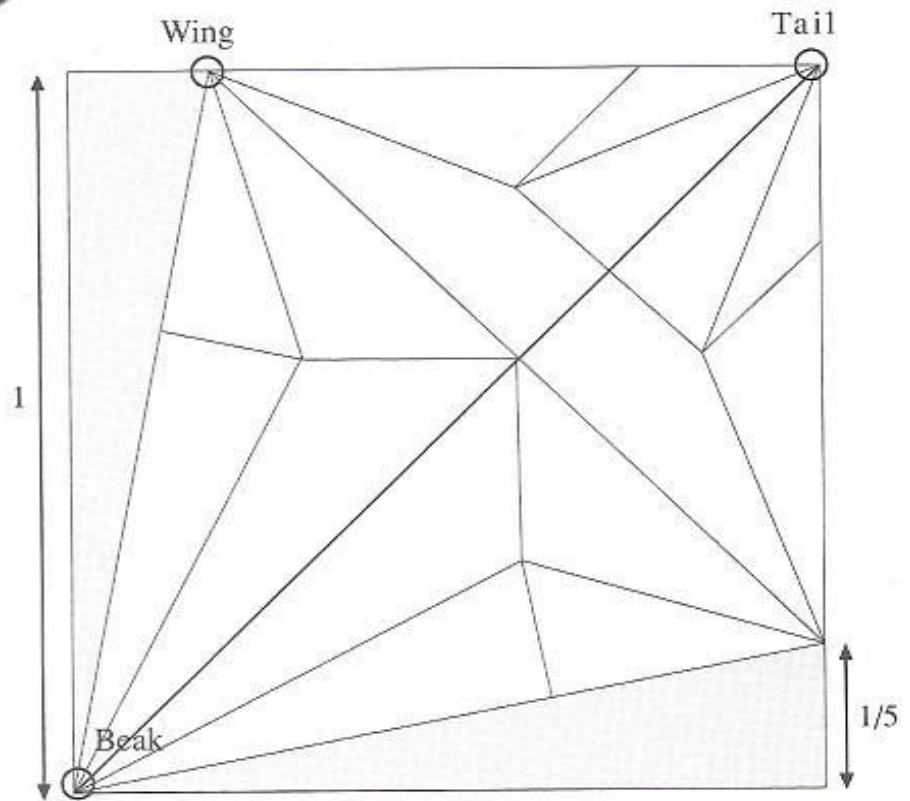
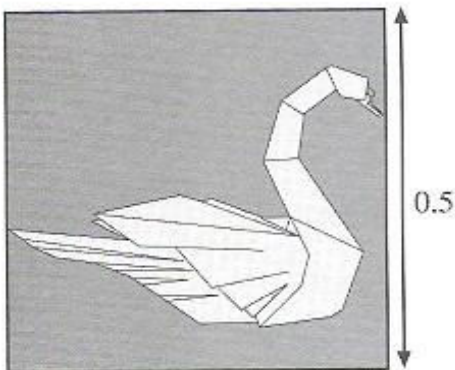

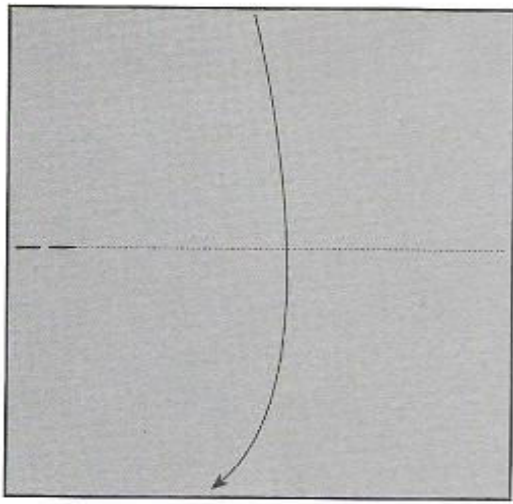

1 ⊖

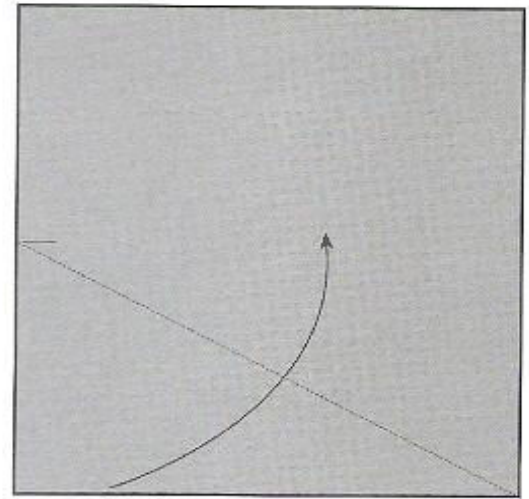

2

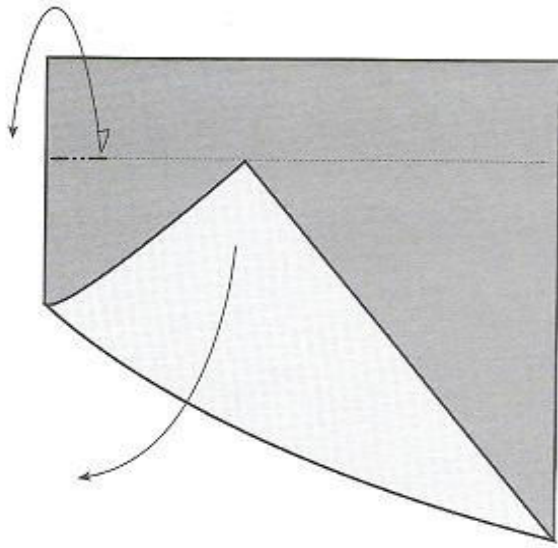

3

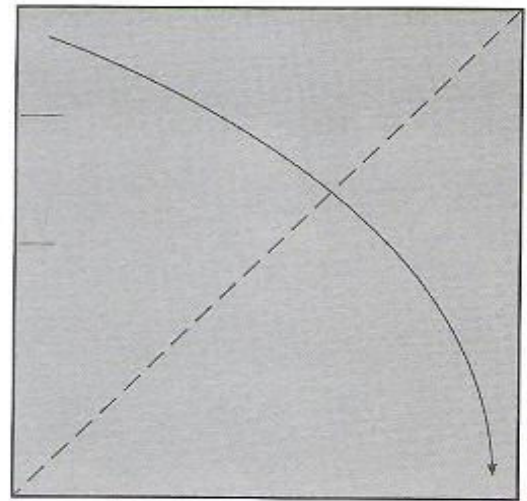

4

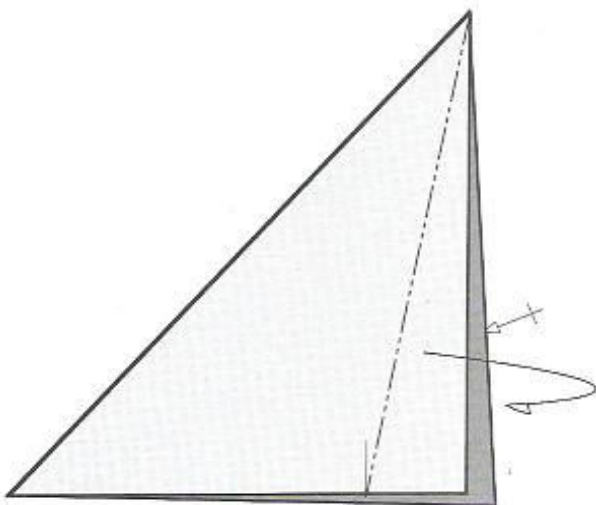

5

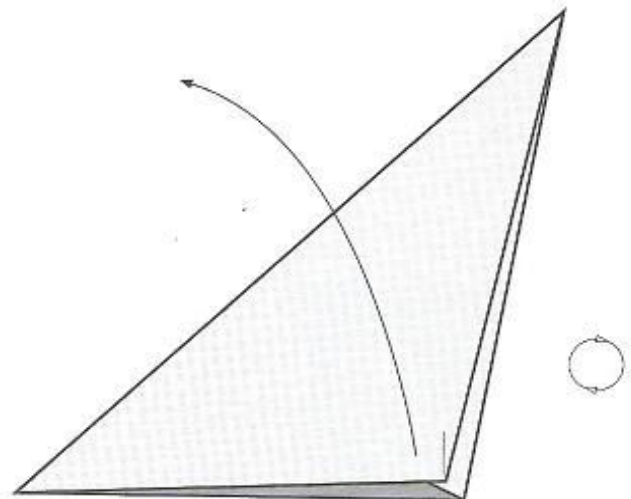

6

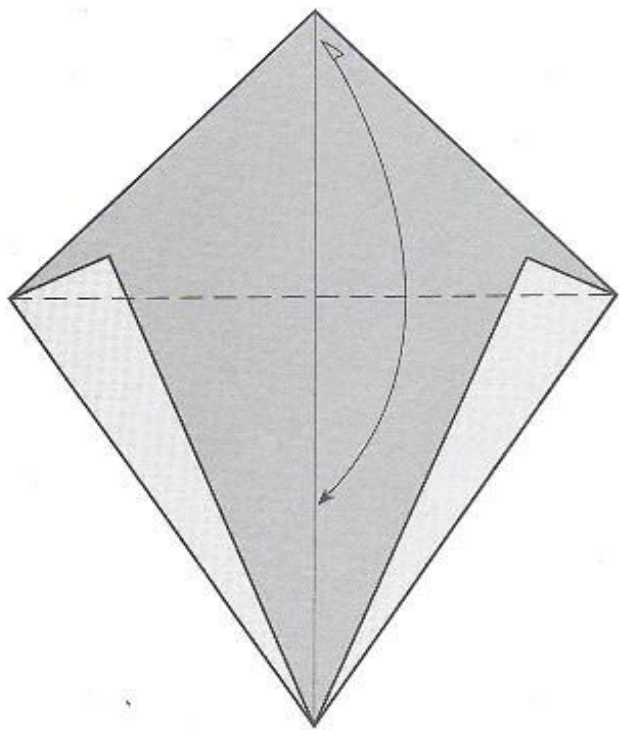

7

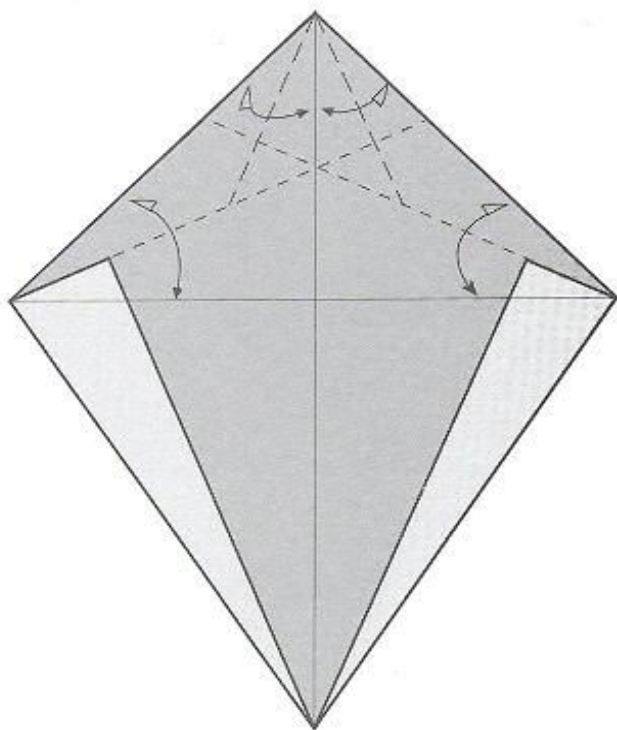

8

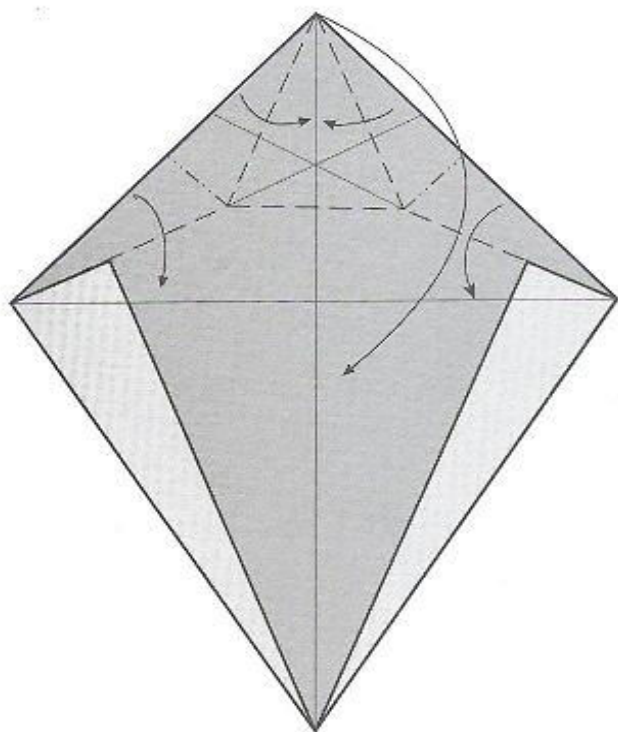

9

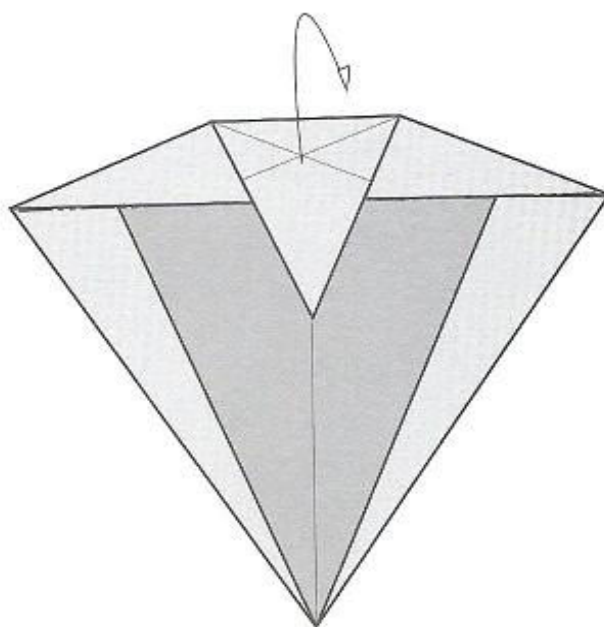

10

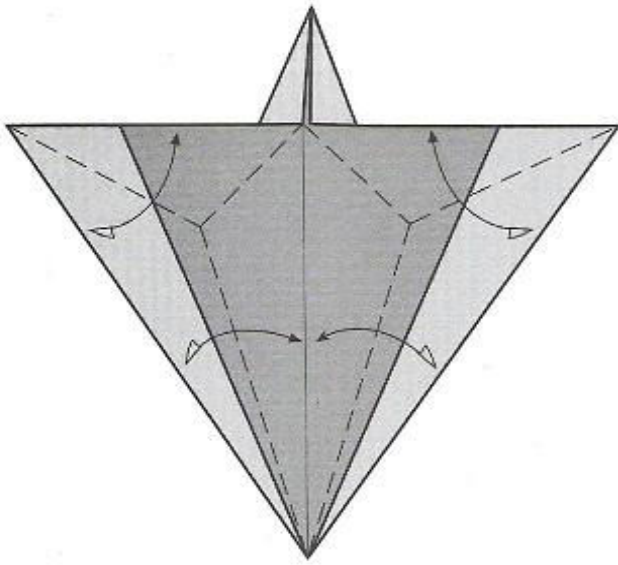

11

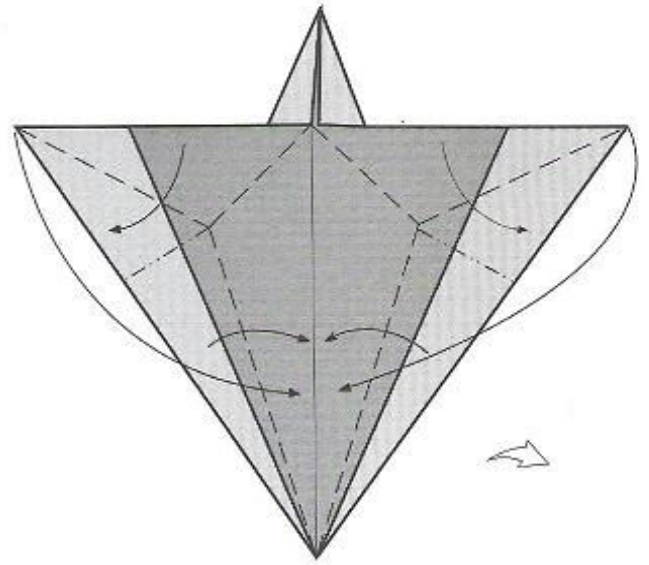

12

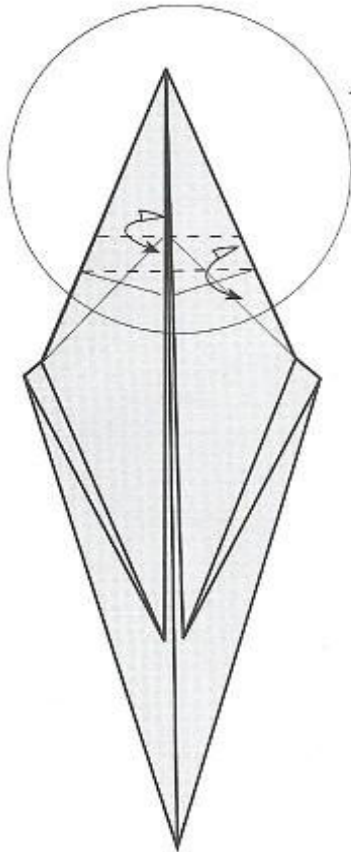

13

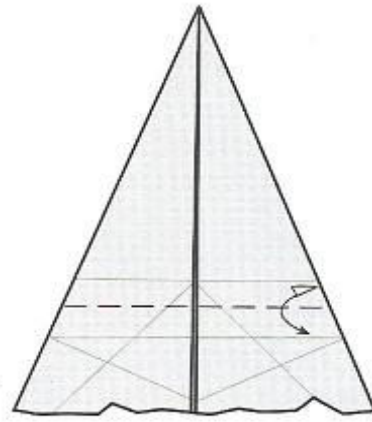

14

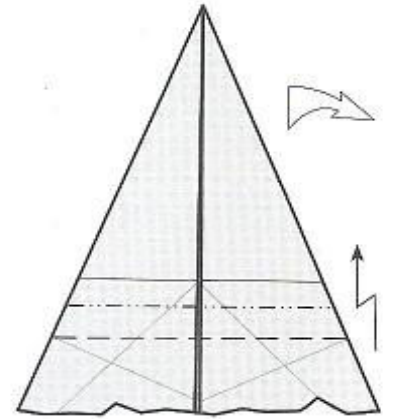

15

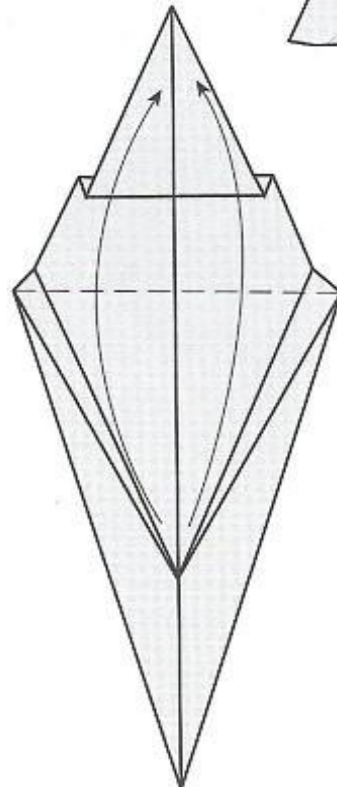

16

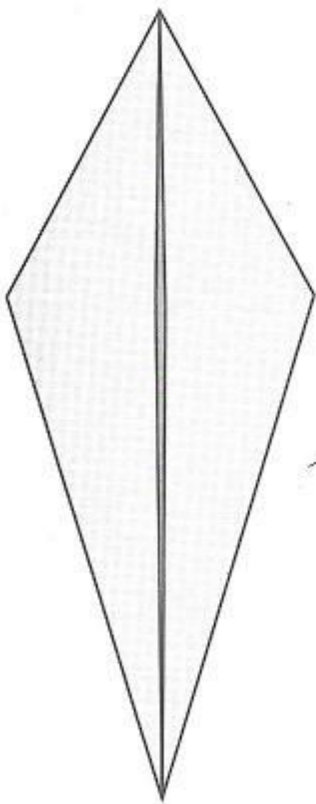

17

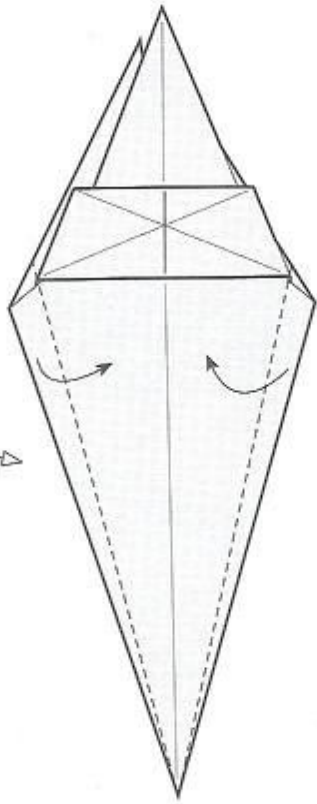

18

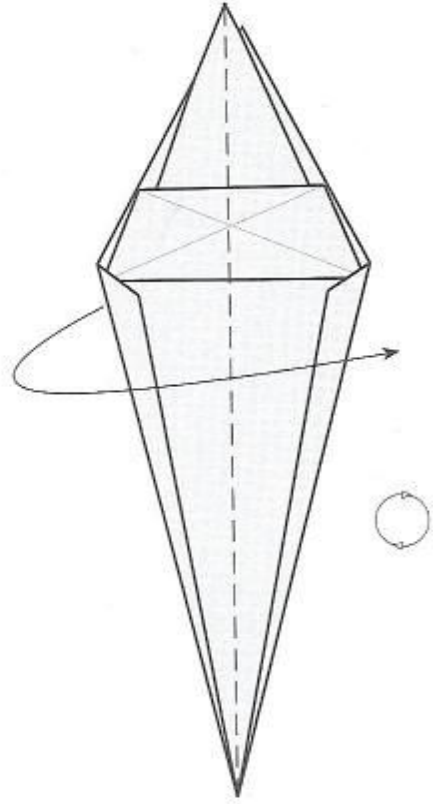

19

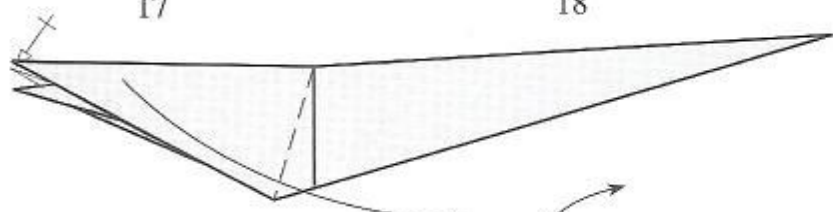

20

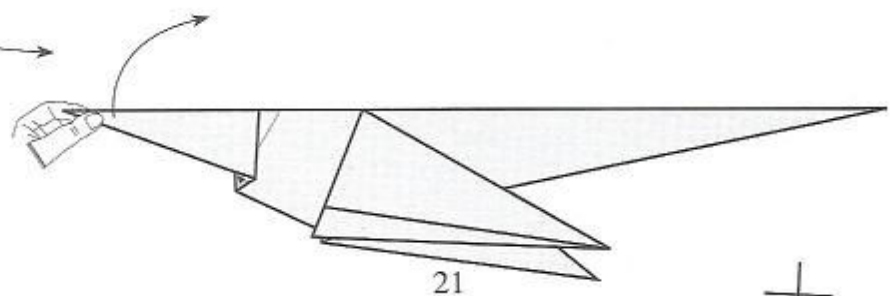

21

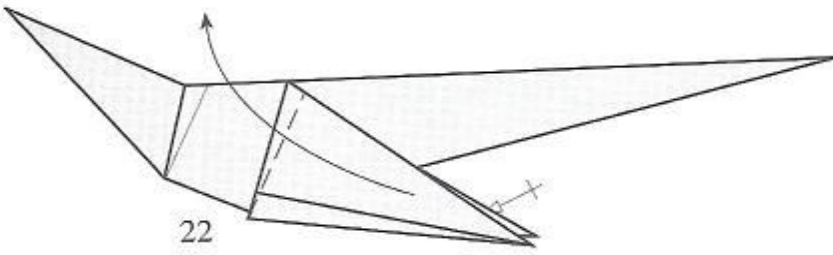

22

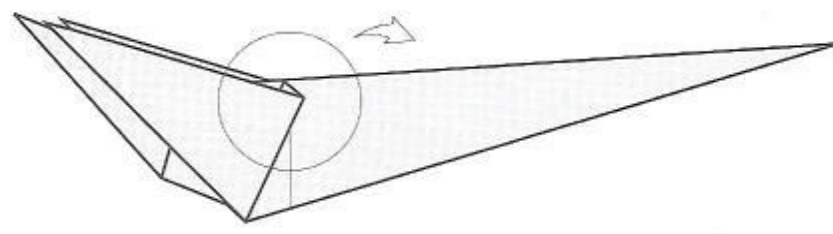

23

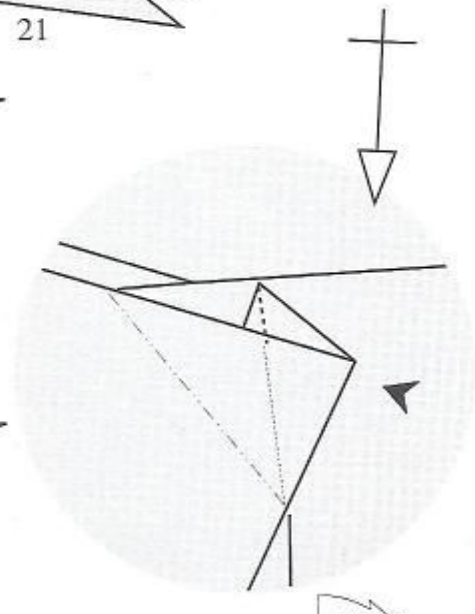

24

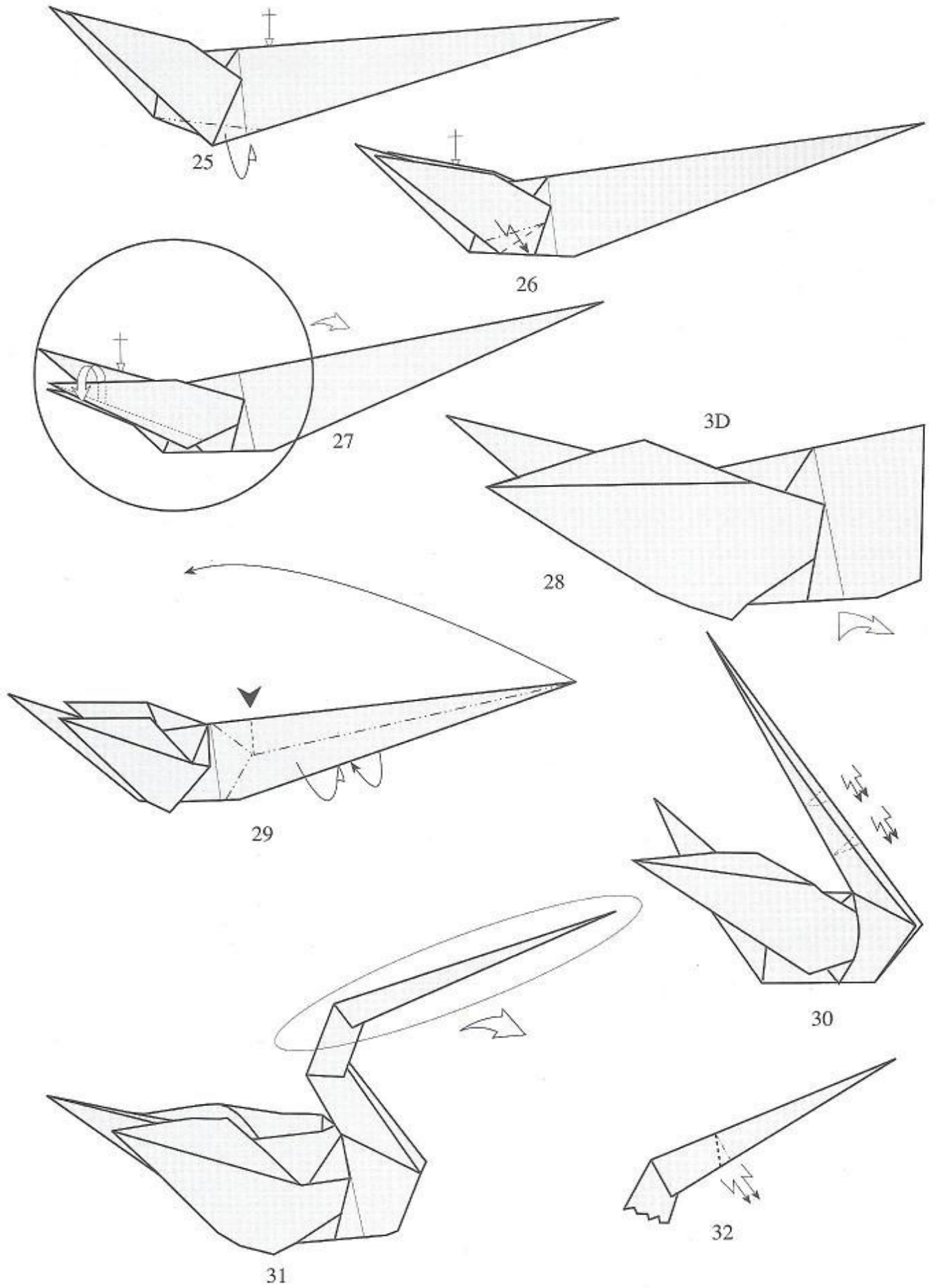

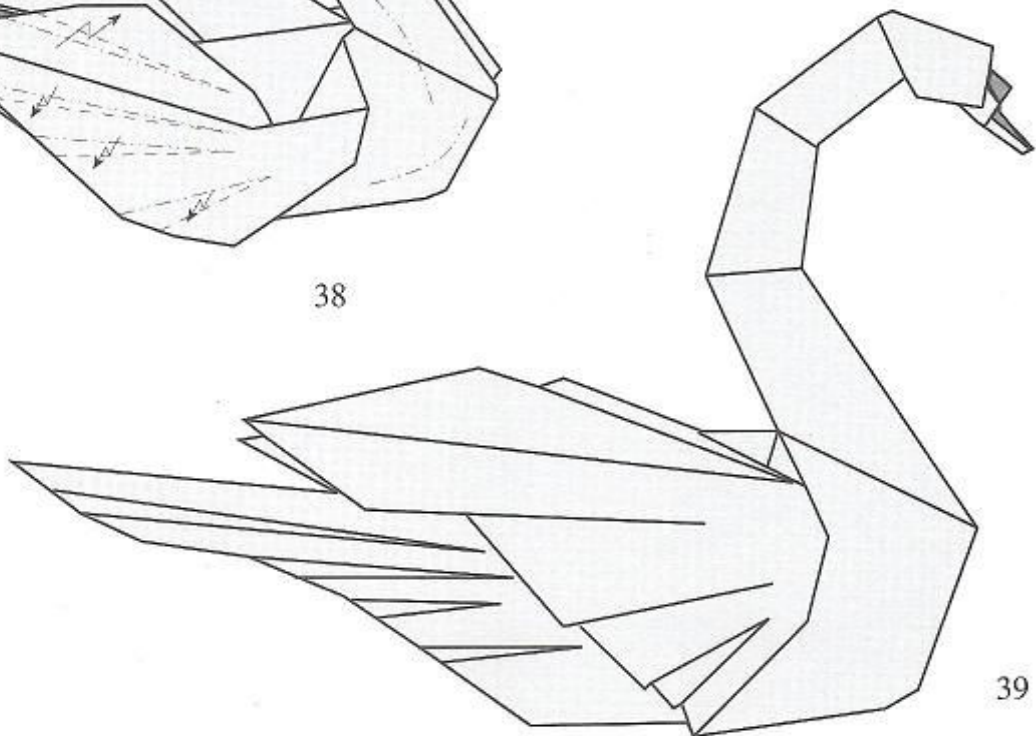
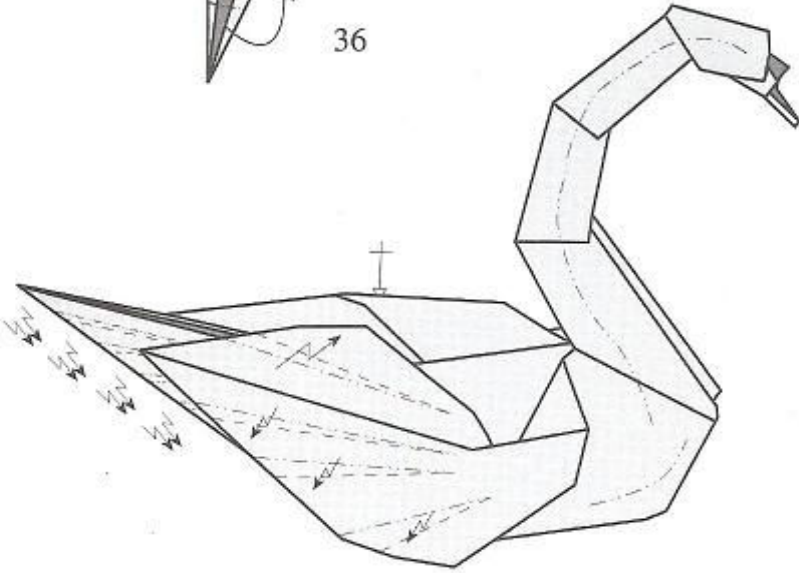
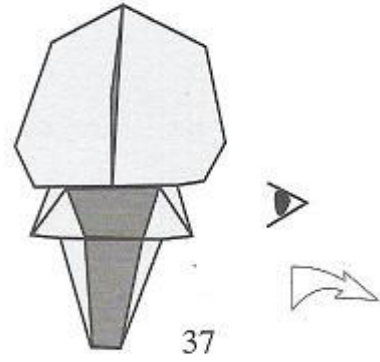
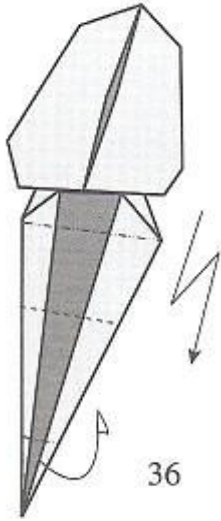
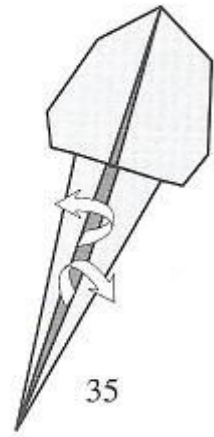
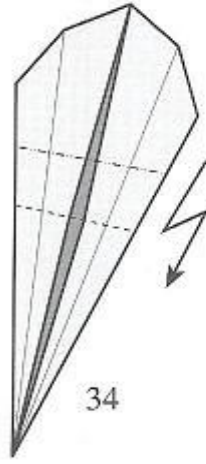
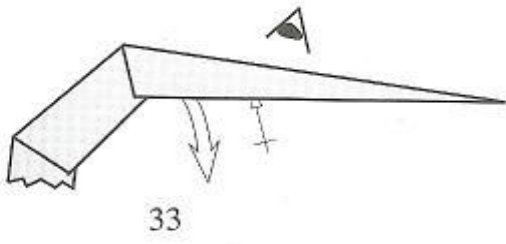

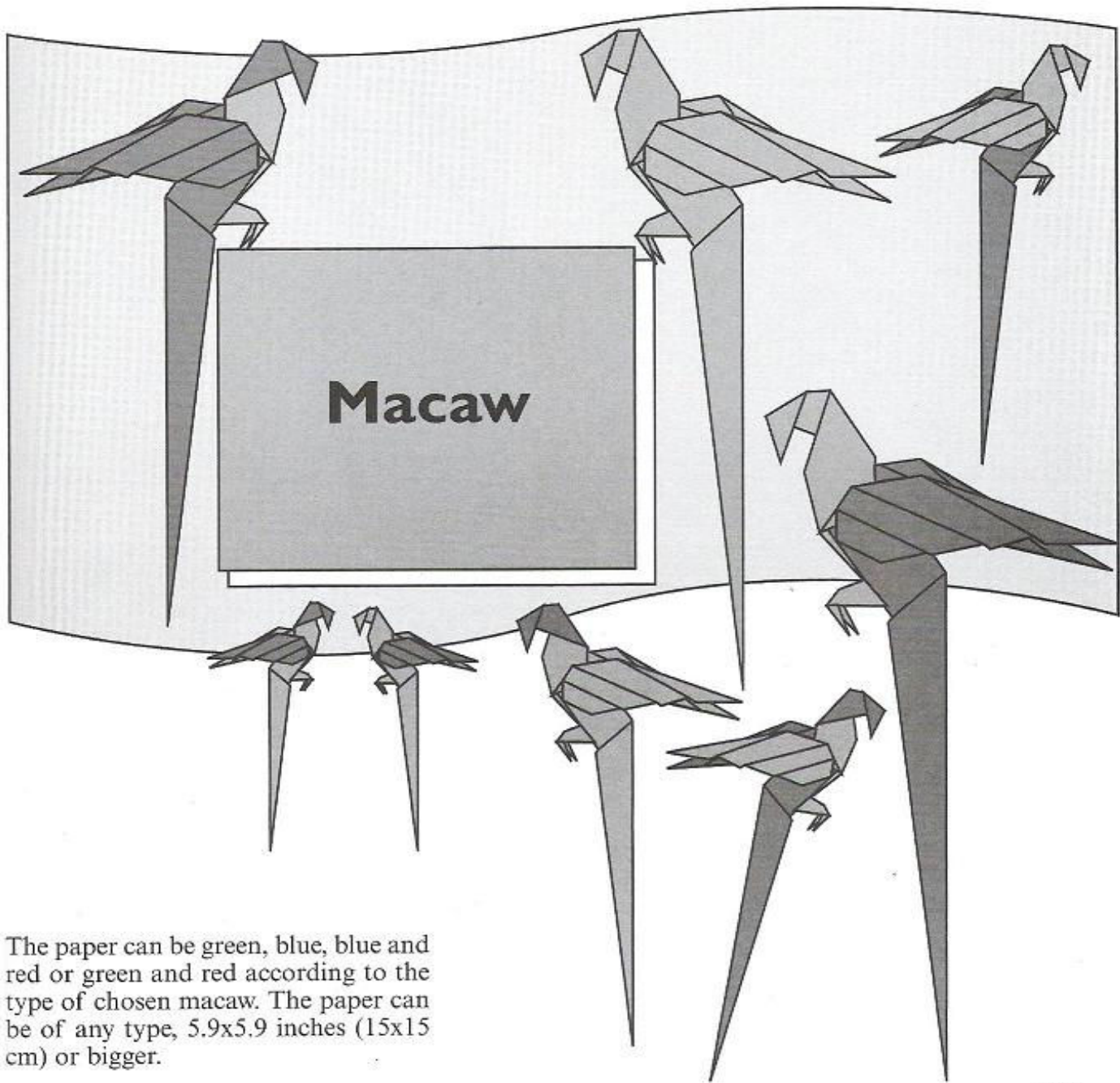

The paper can be green, blue, blue and red or green and red according to the type of chosen macaw. The paper can be of any type, 5.9x5.9 inches (15x15 cm) or bigger.

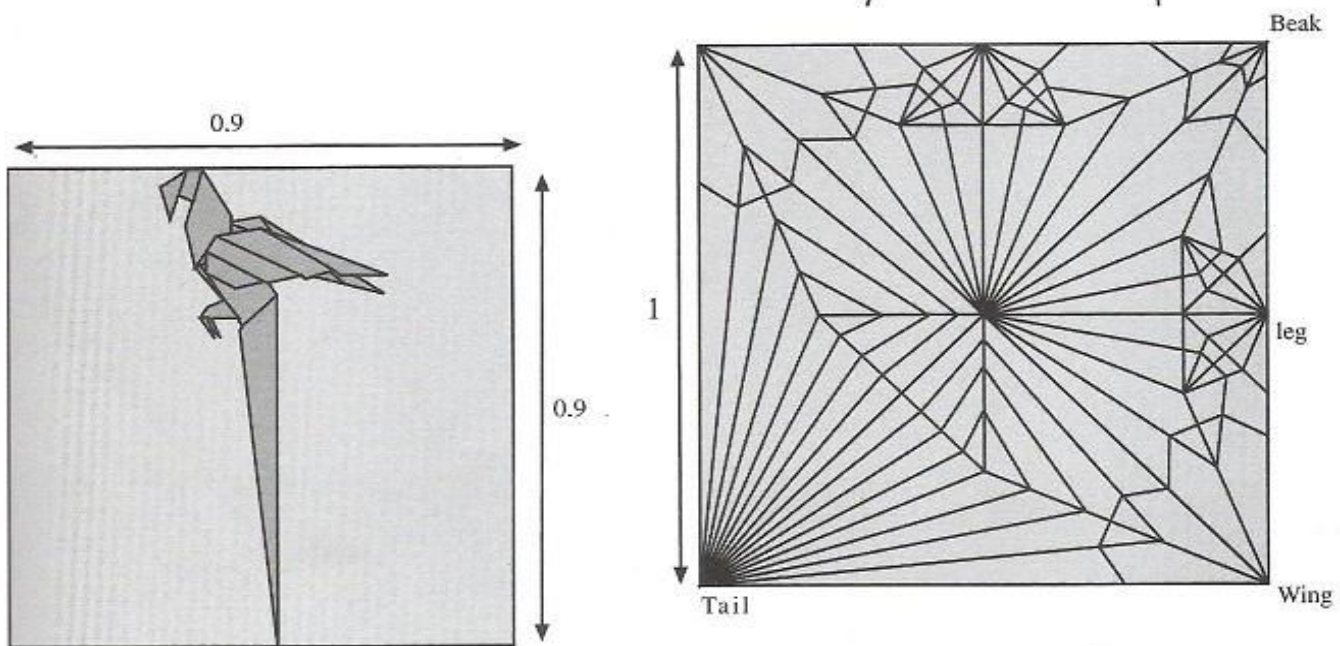

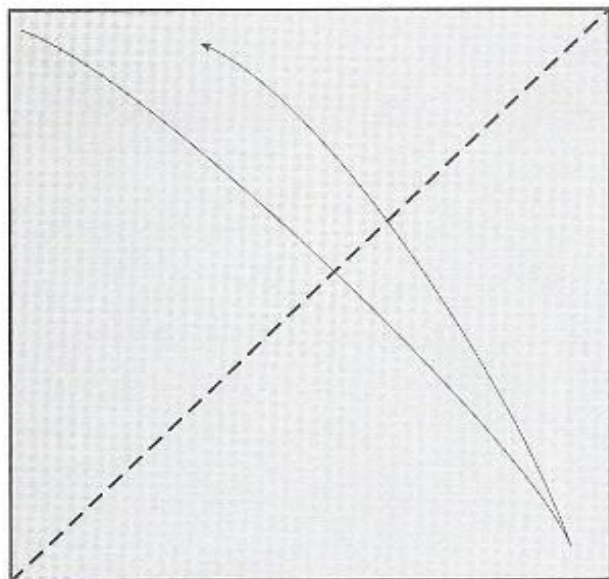

1

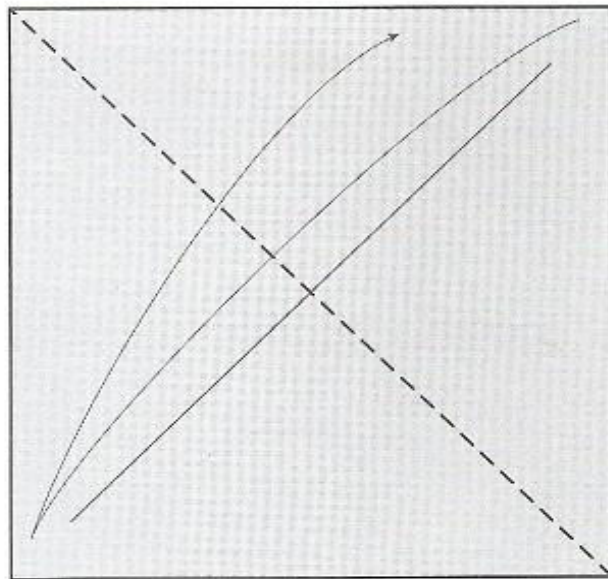

2

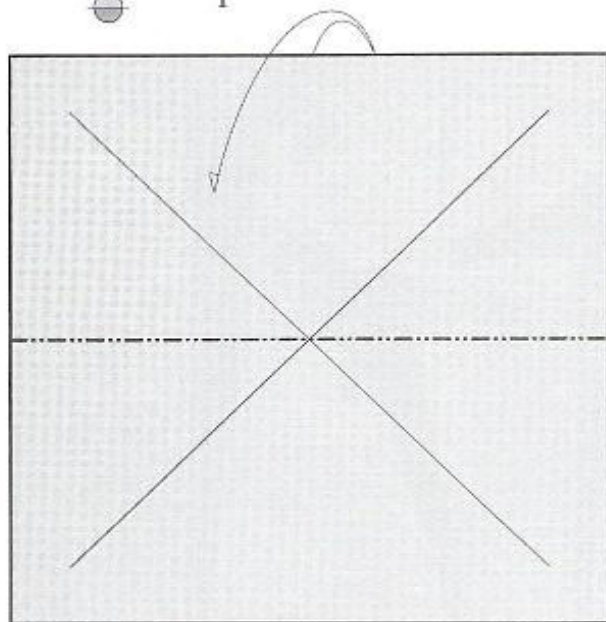

3

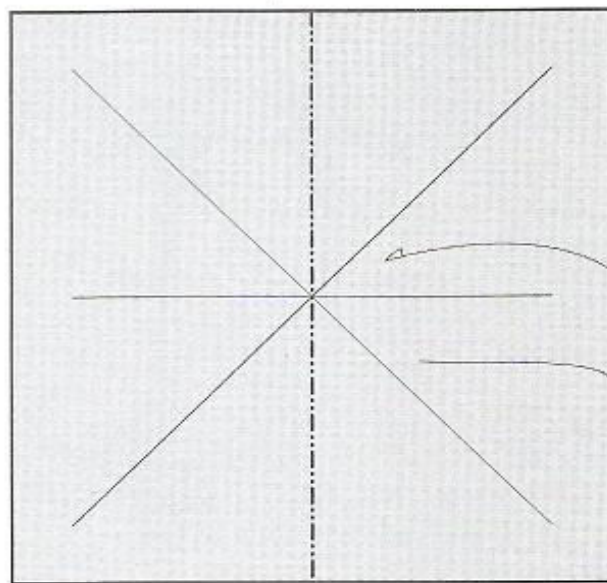

4

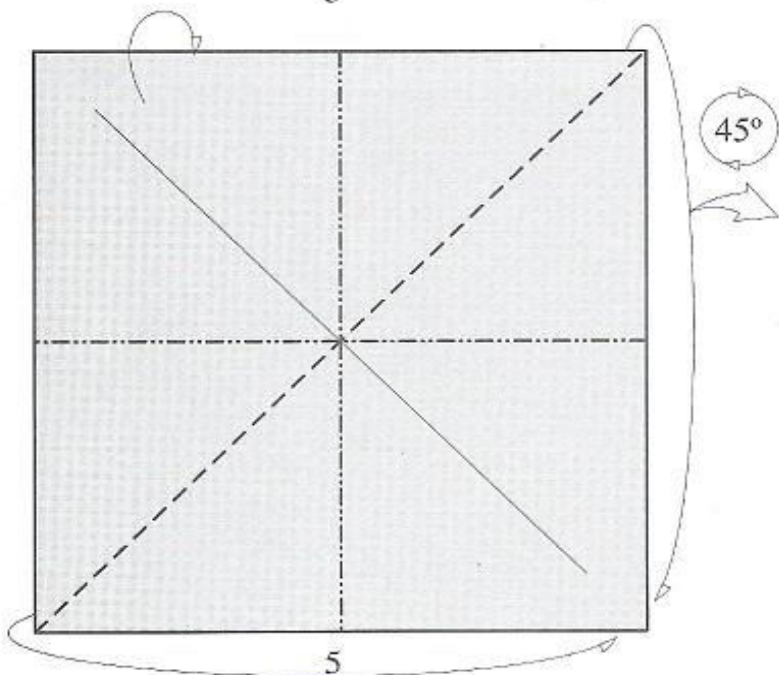

5

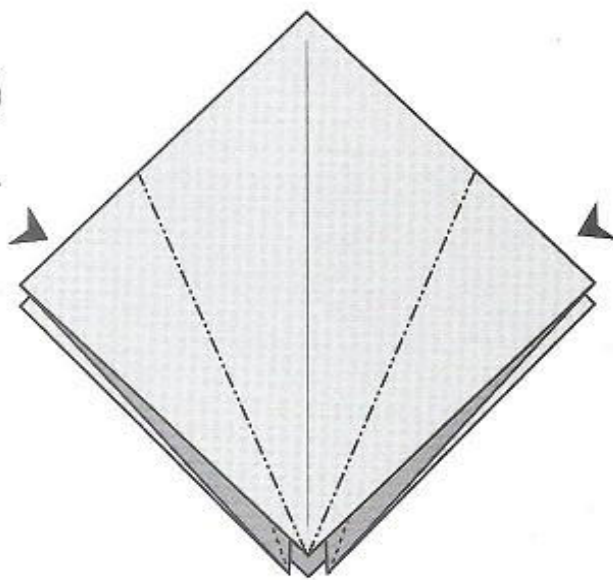

6

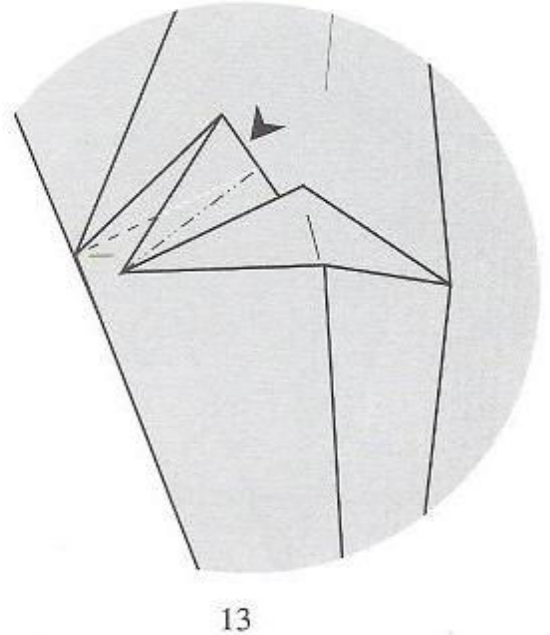
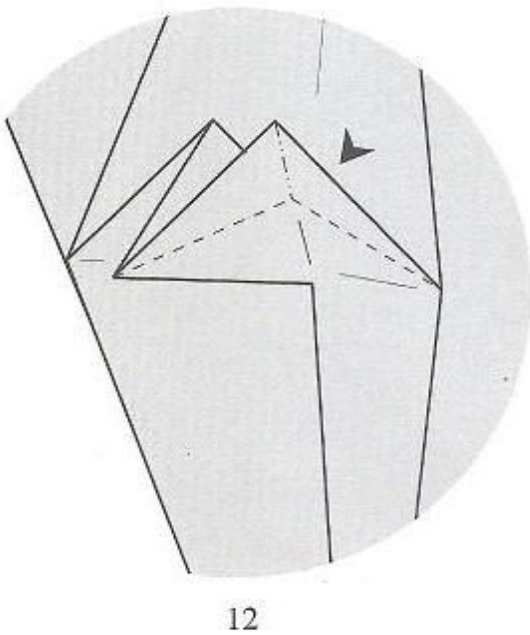
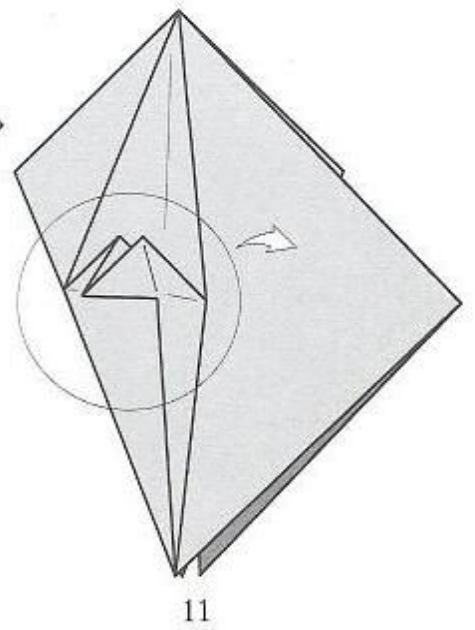
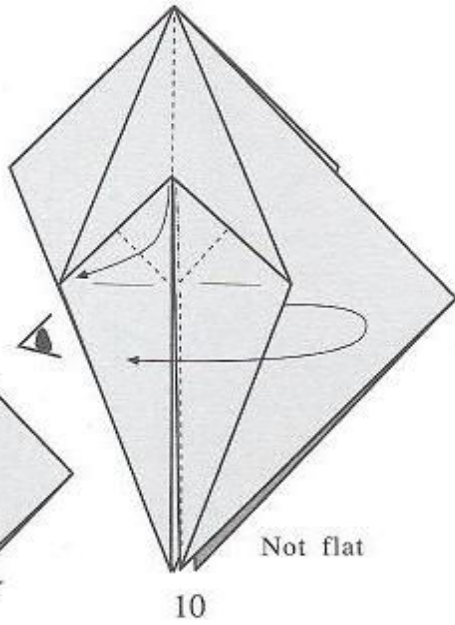
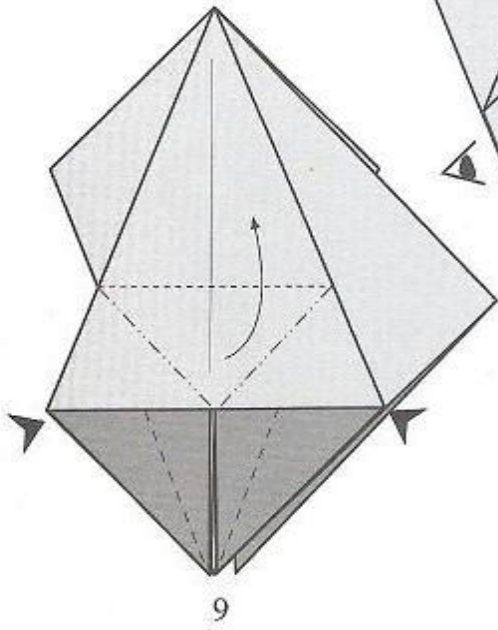
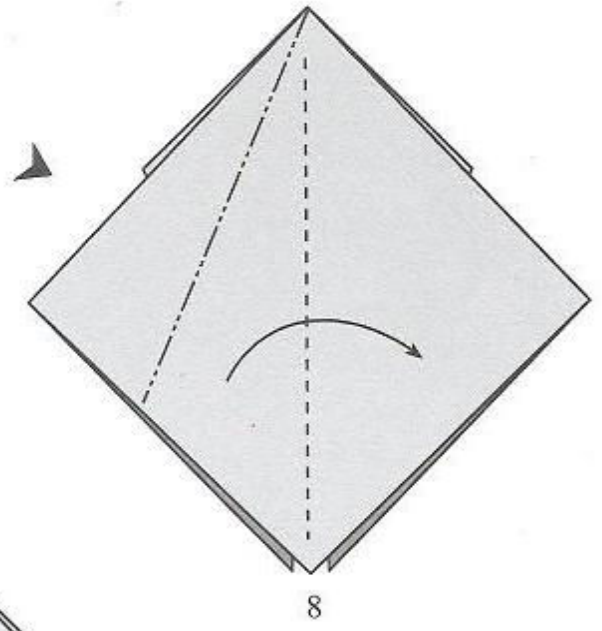
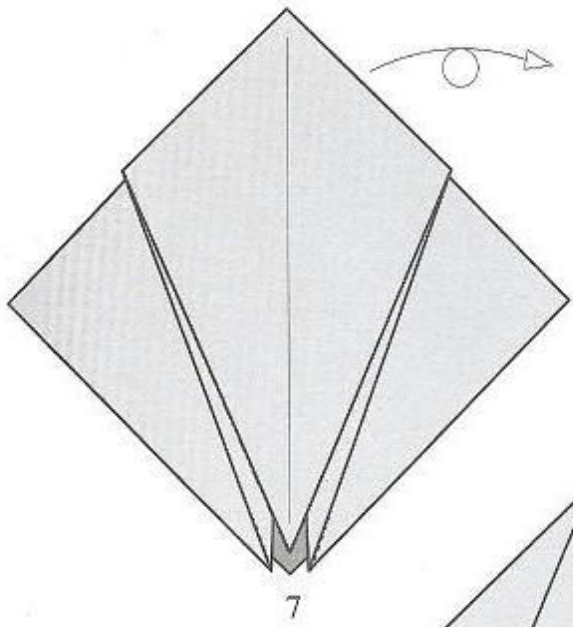

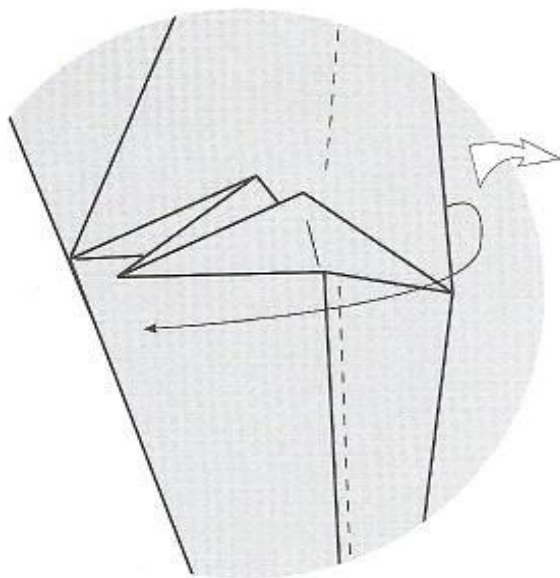

14

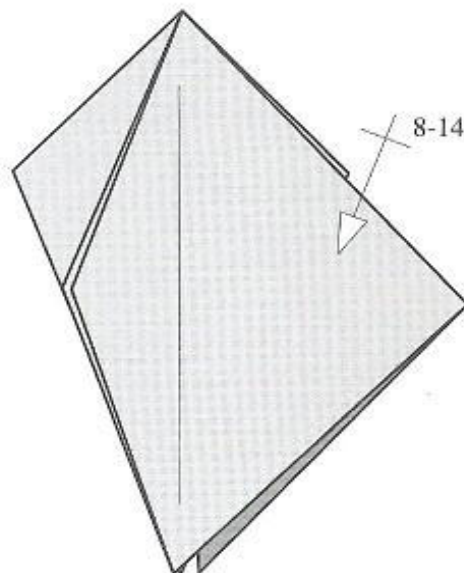

15

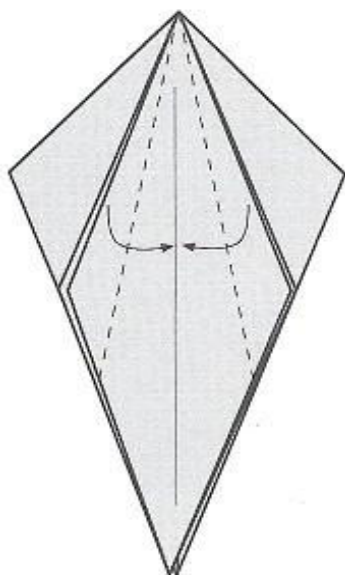

16

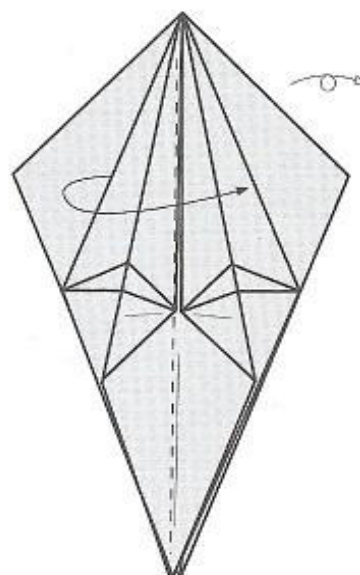

17

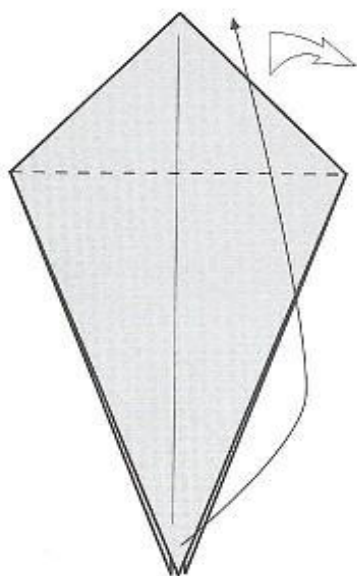

18

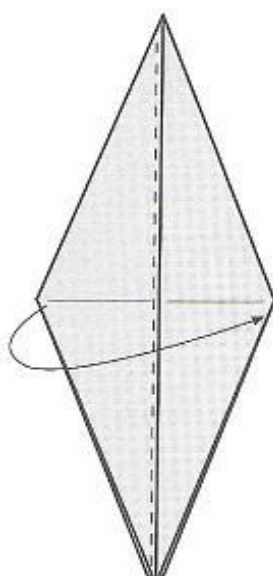

19

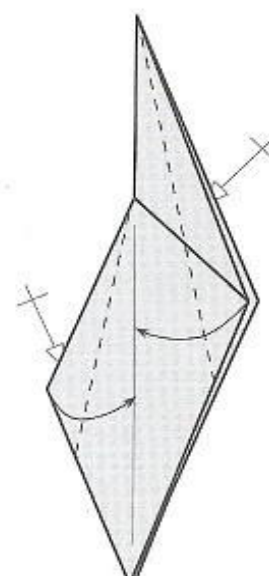

20

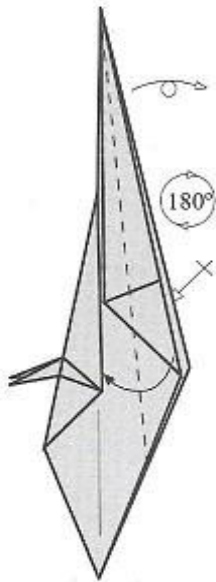

21

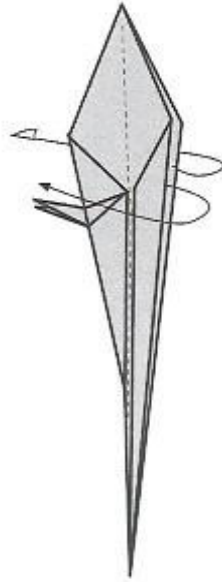

22

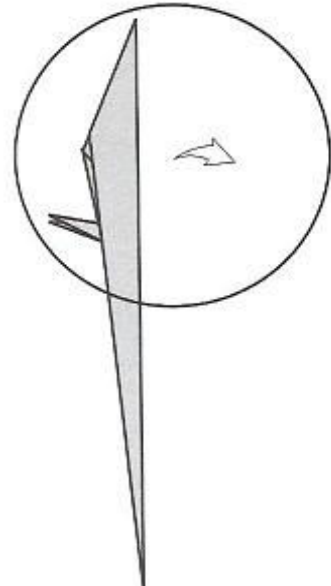

23

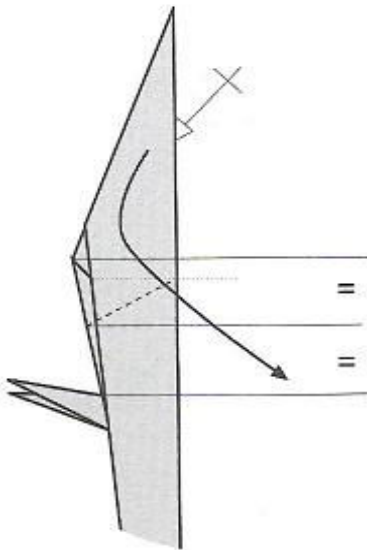

24

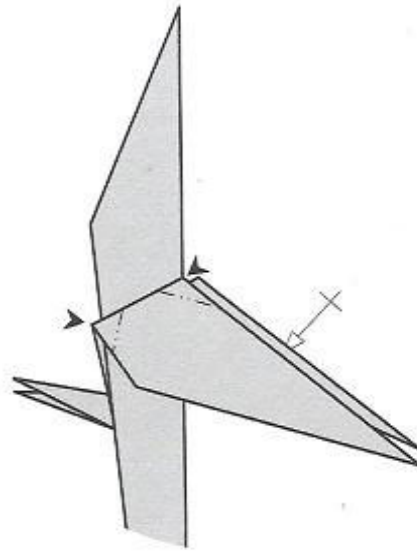

25

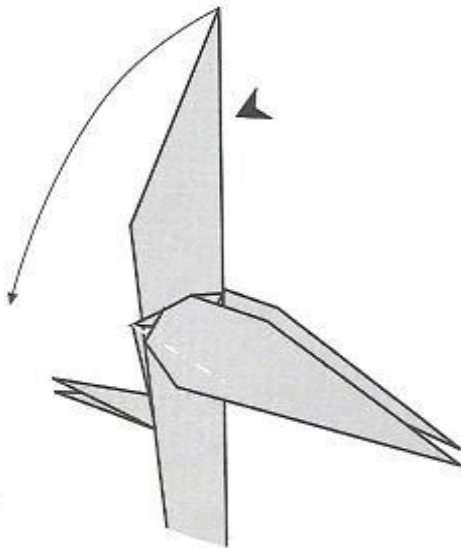

26

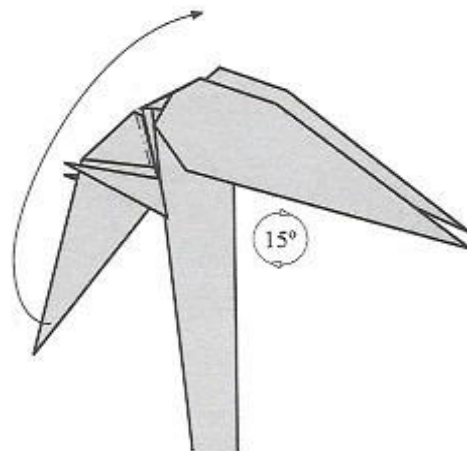

27

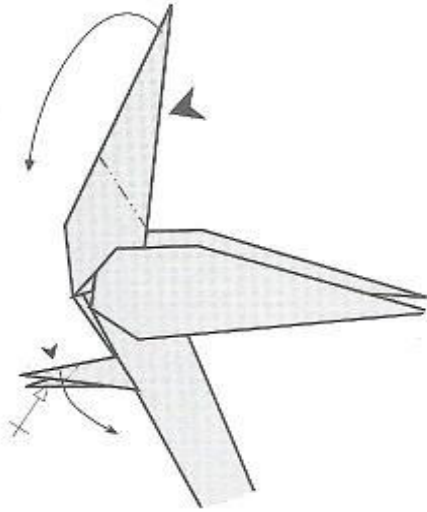

28

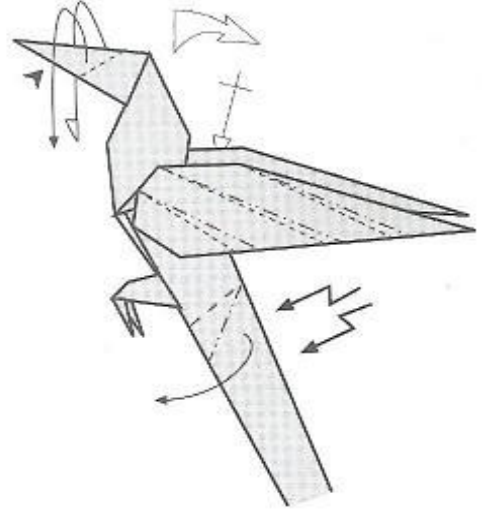

29

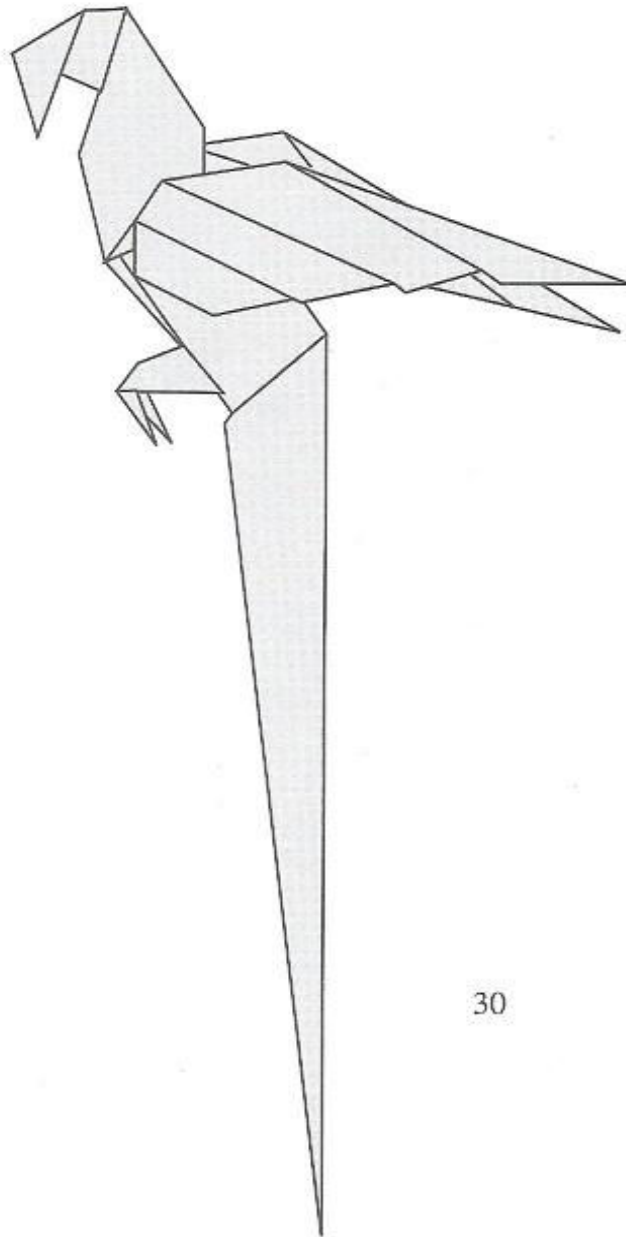

30

Bicolor macaws

Diverse variants

J. C. Borrego and M. Sirgo

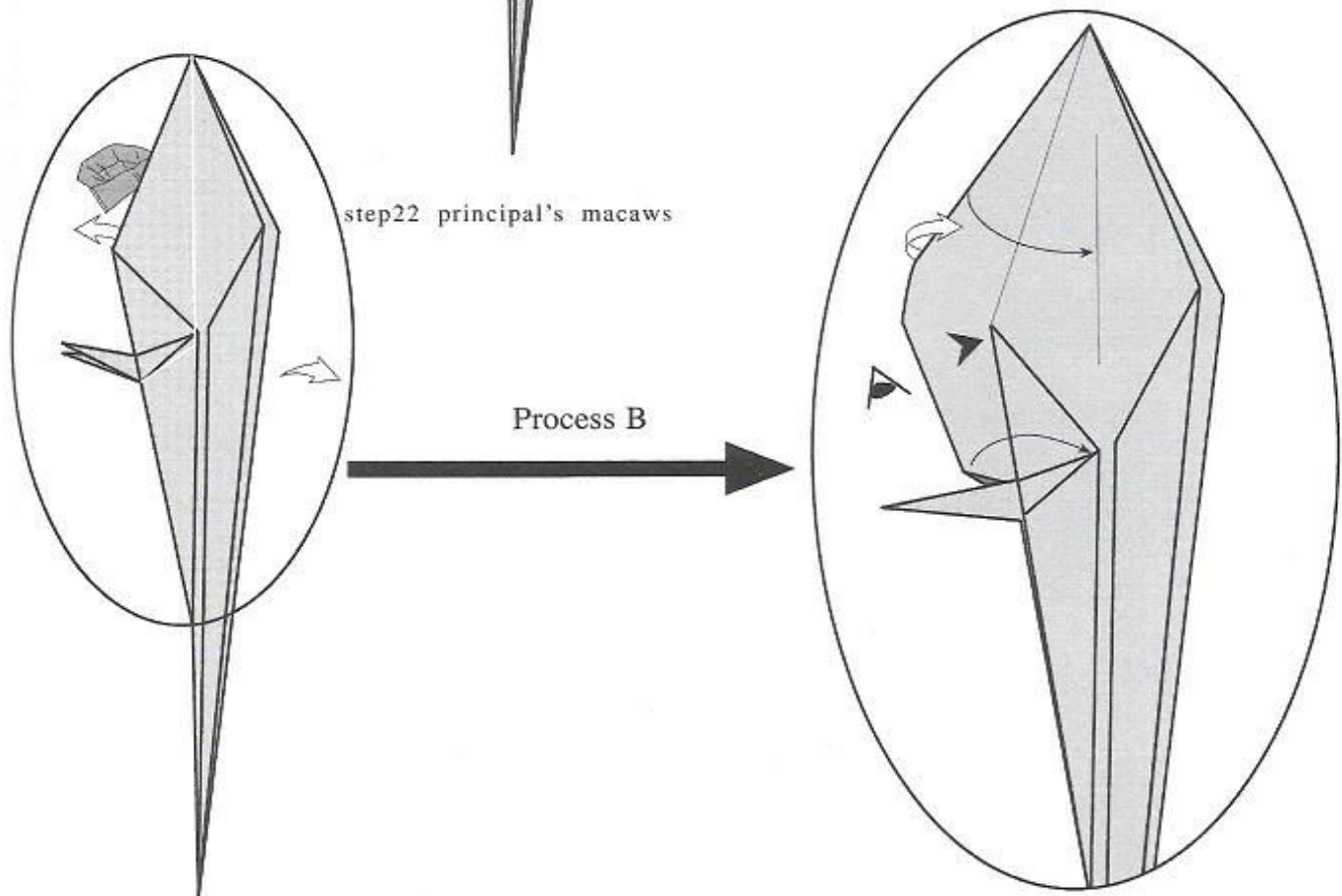
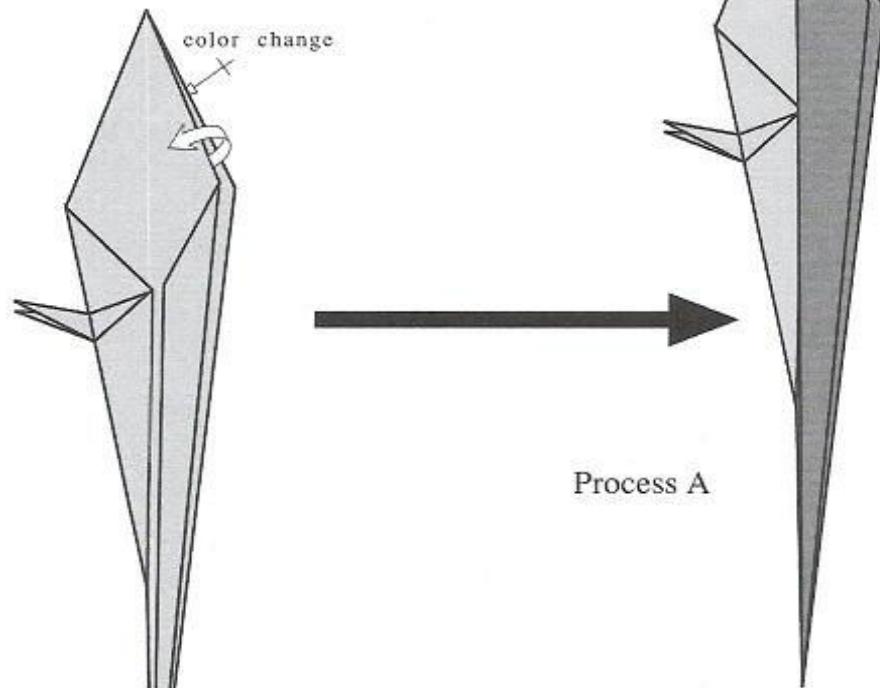

step22 principal's macaws

B-1

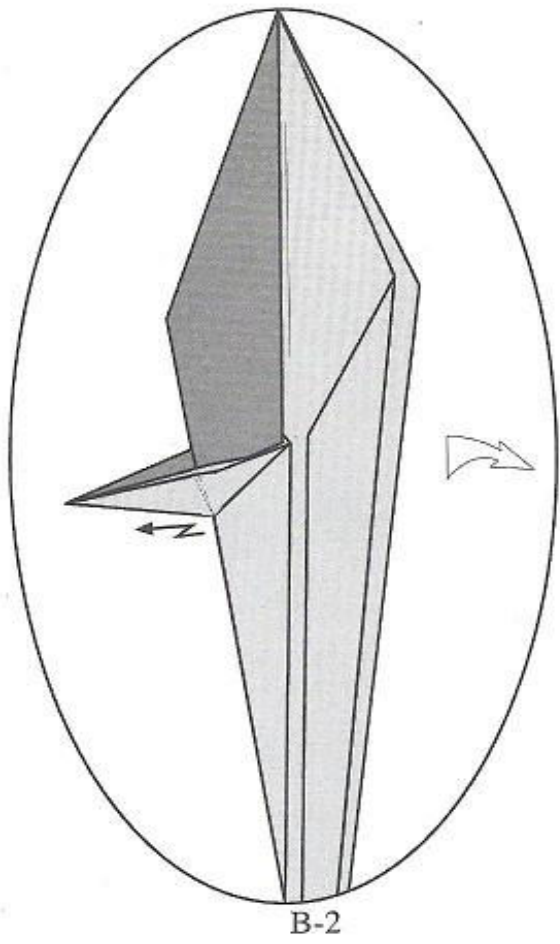

B-2

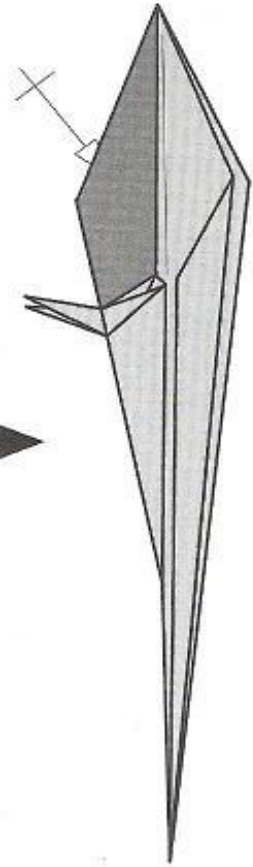

B-3

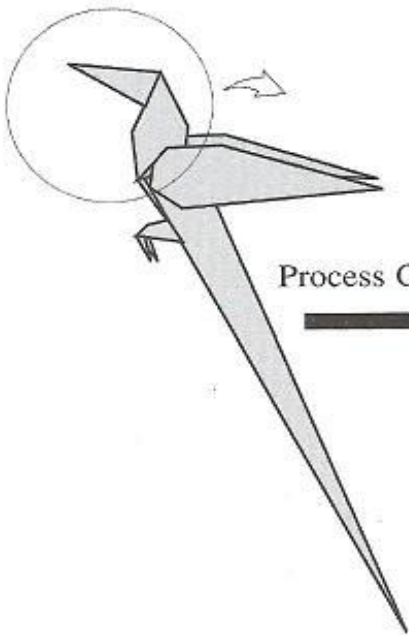

Step 29 of main macaw

Process C

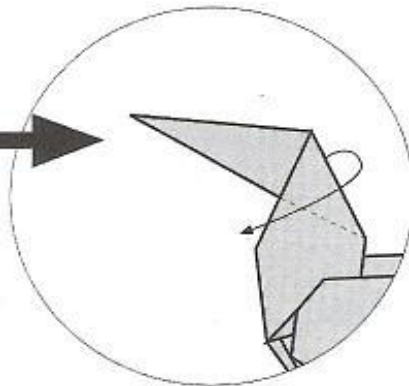

C-1

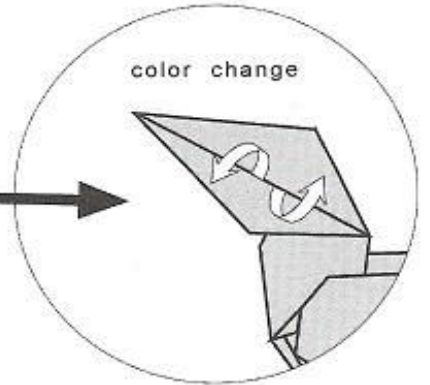

C-2

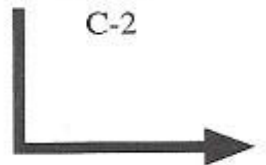

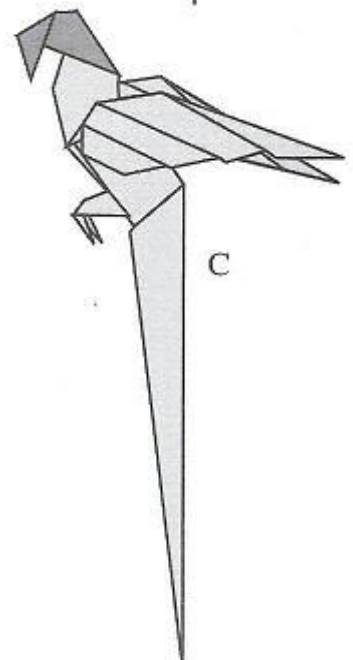
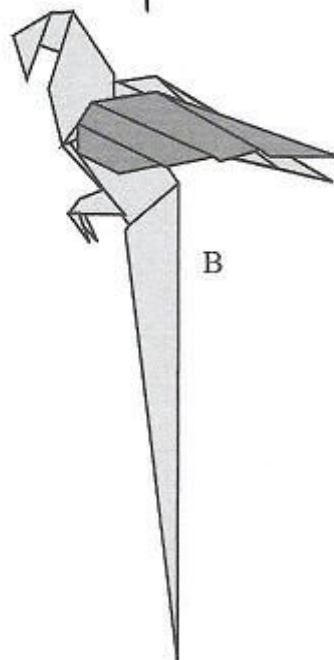
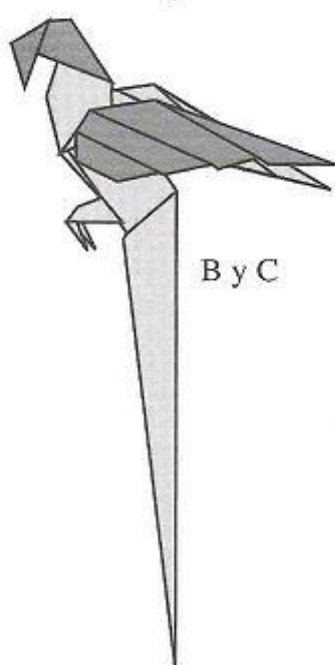
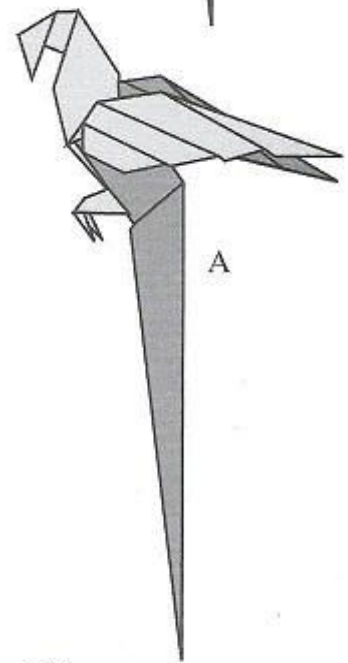
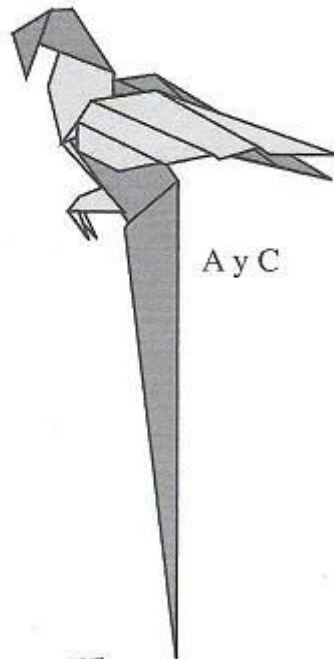
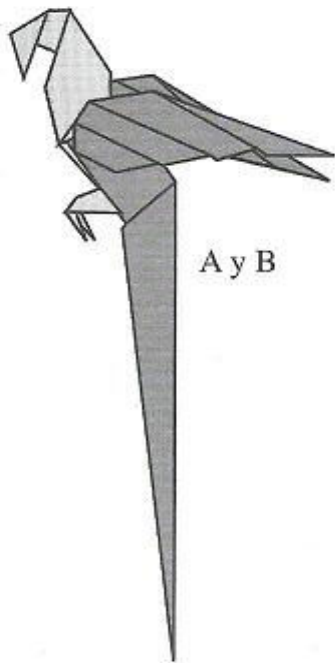
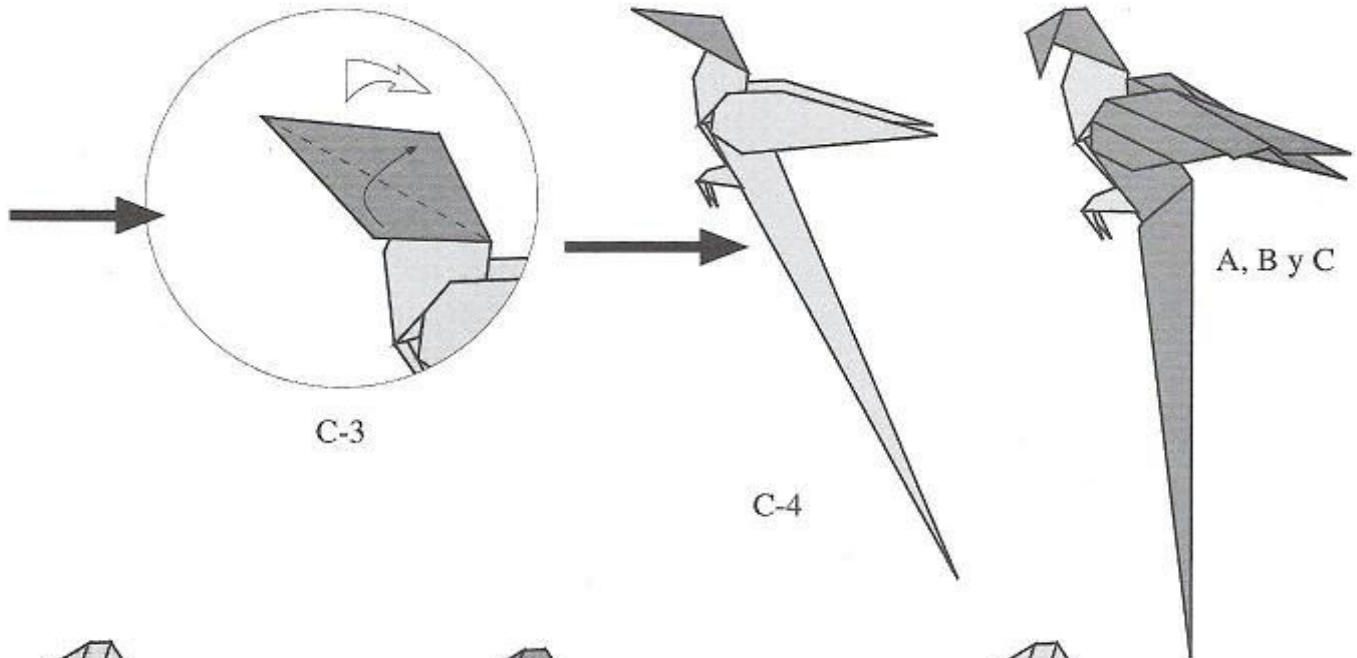

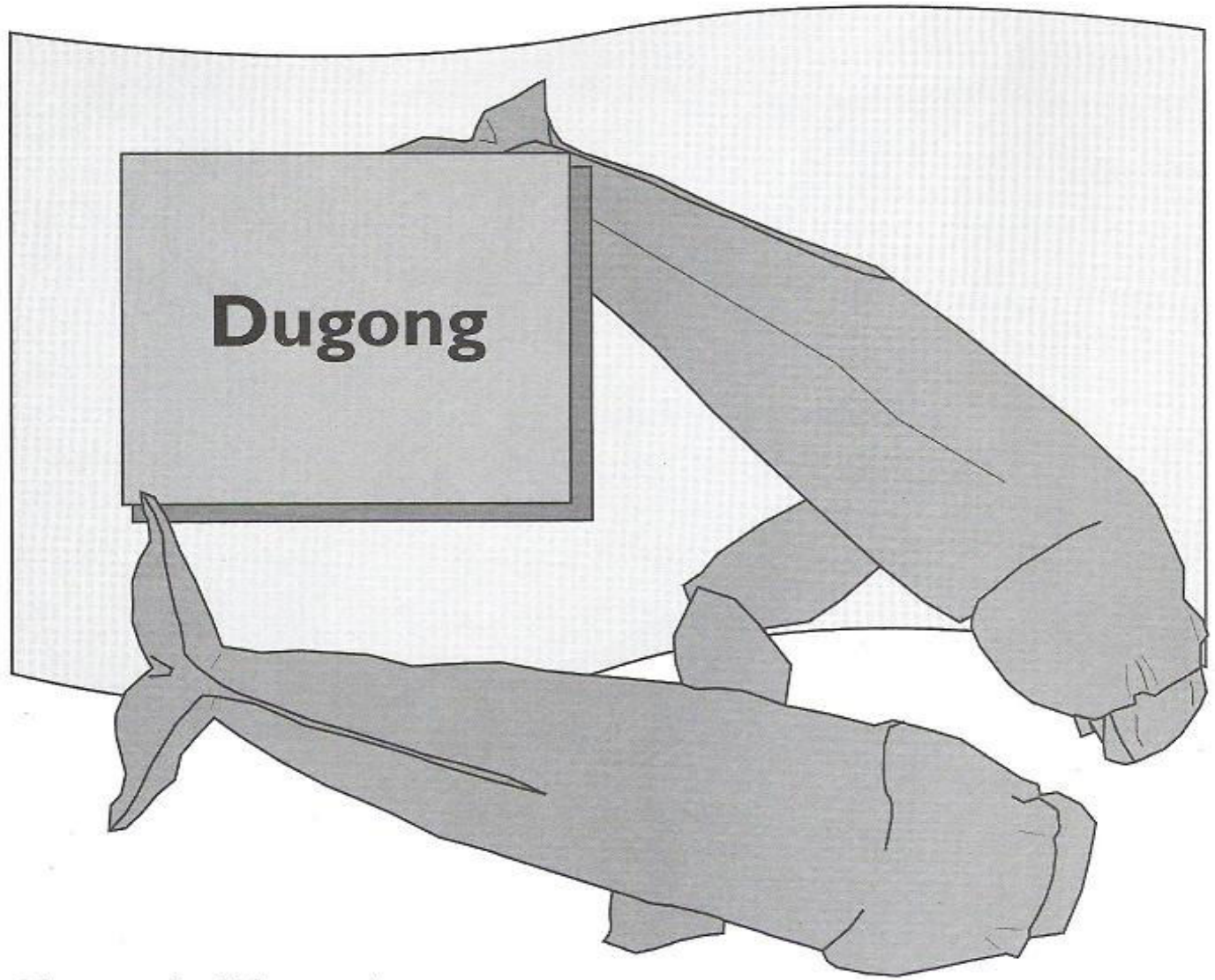

The paper should be gray. Any paper type can be used, 120 grams, using the technique of humidified paper.

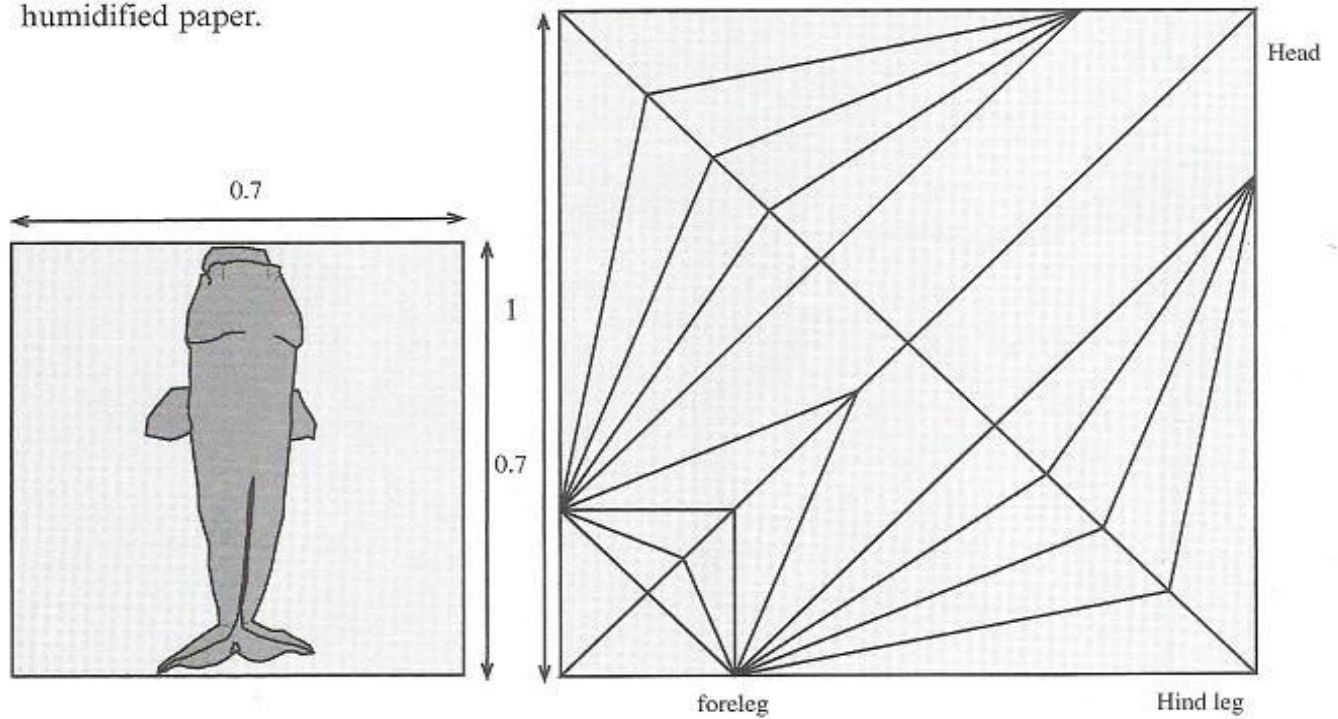

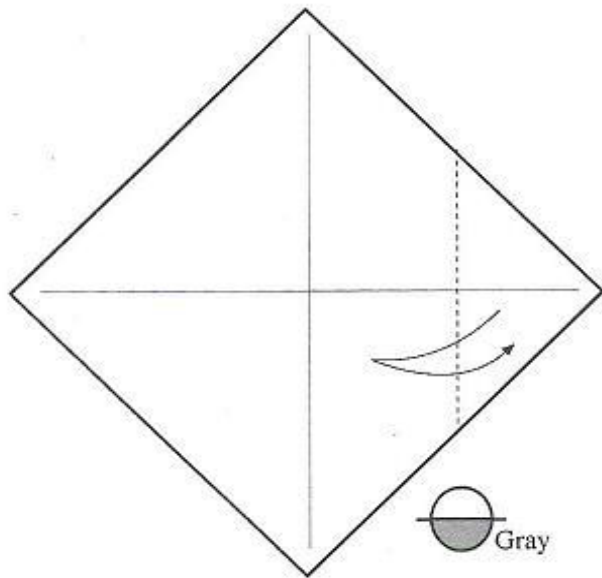

1

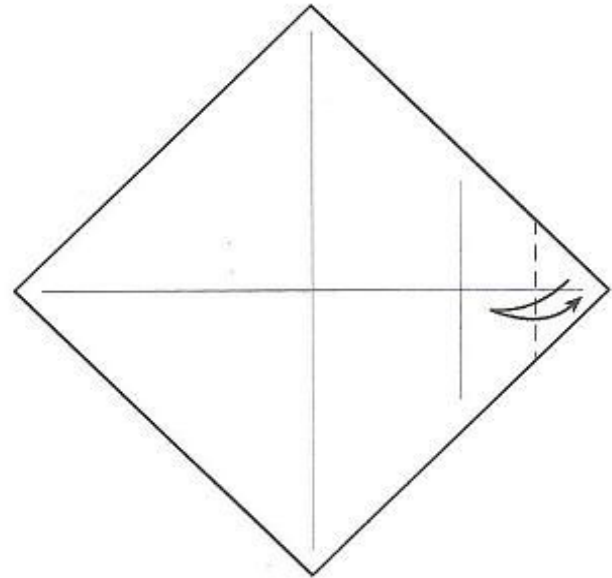

2

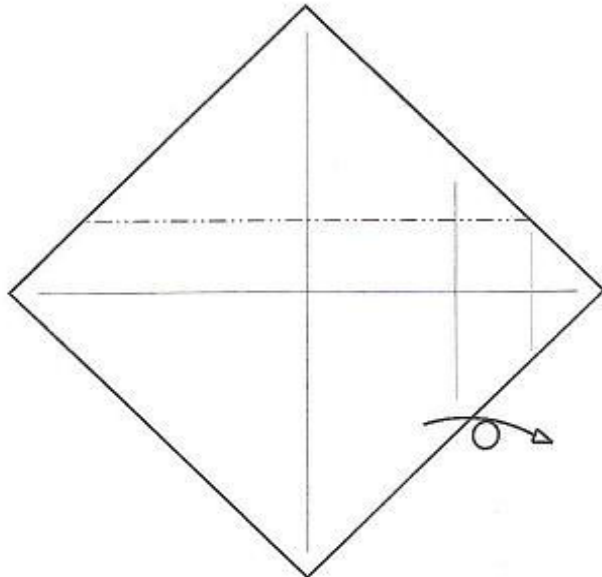

3

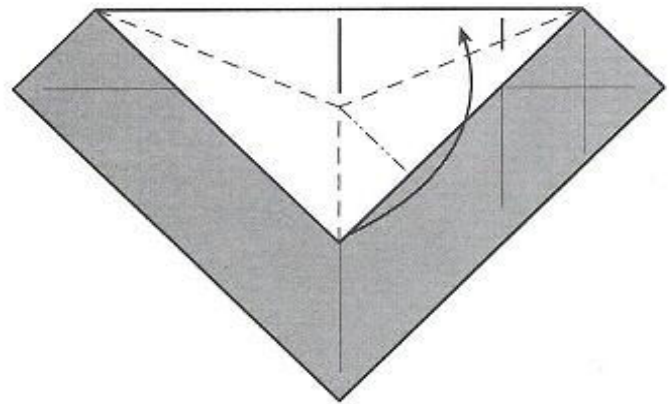

4

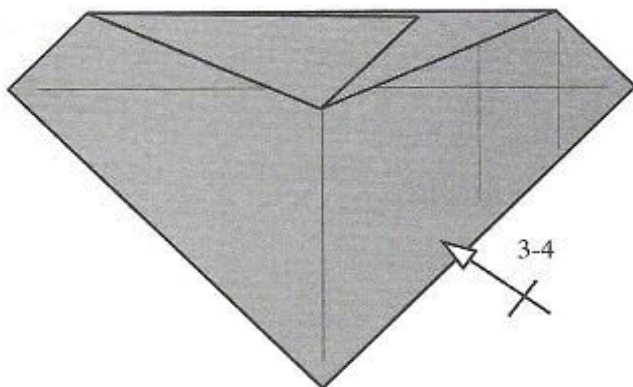

5

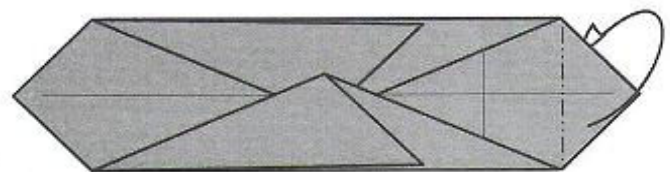

6

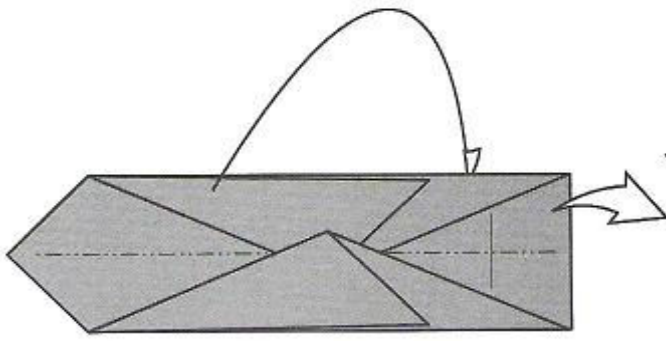

7

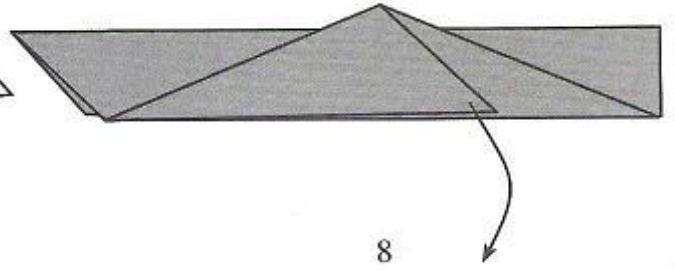

8

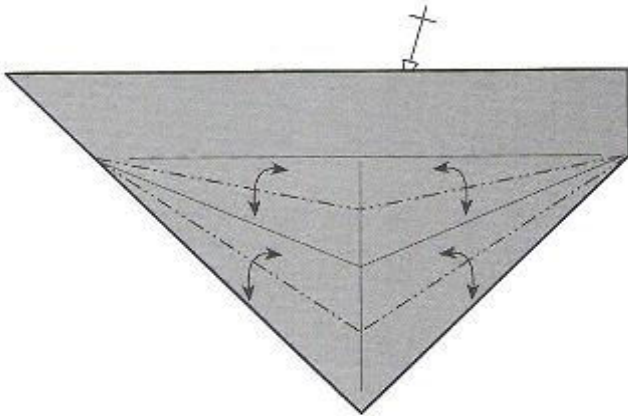

9

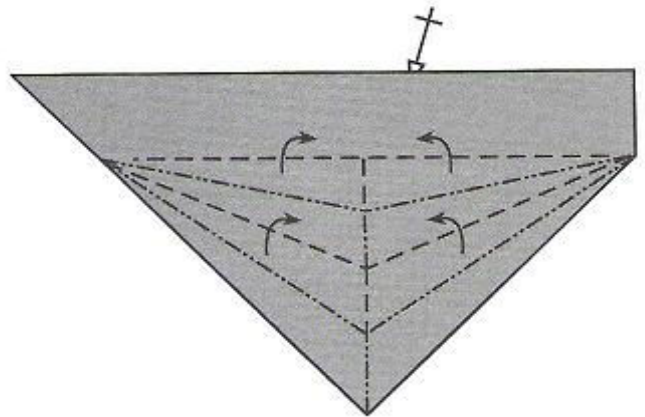

10

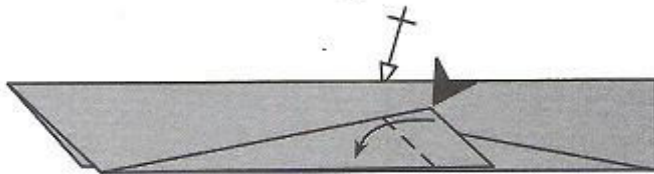

11

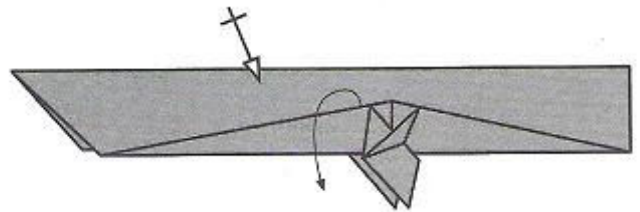

12

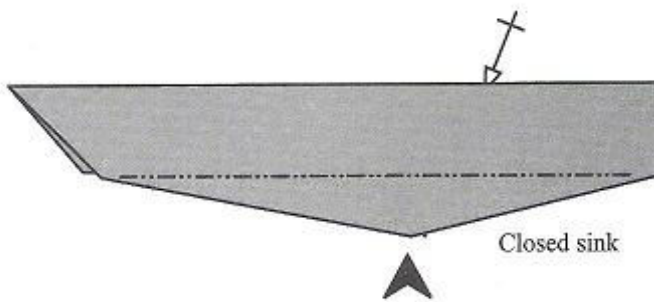

13

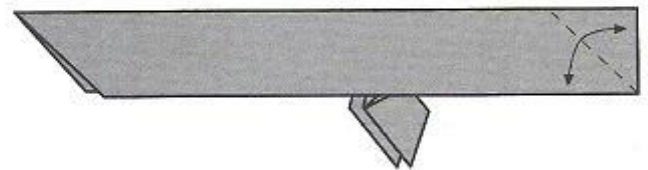

14

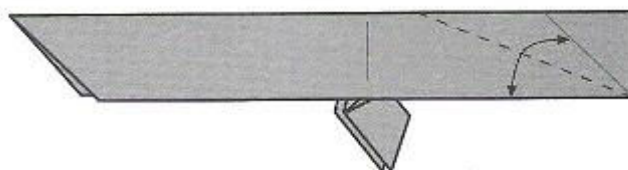

15

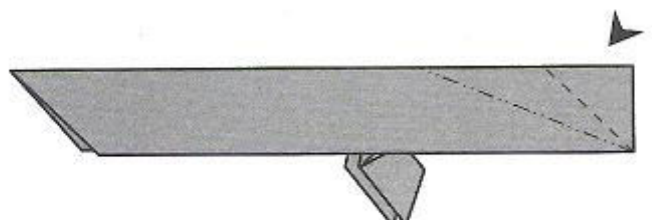

16

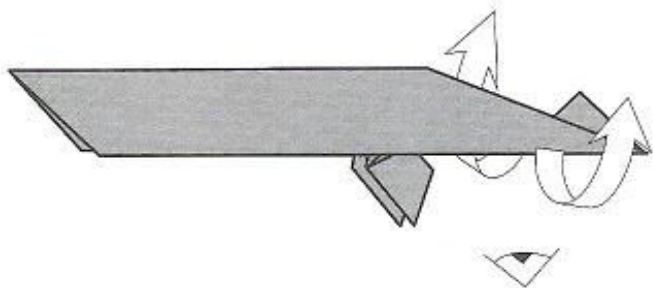

17

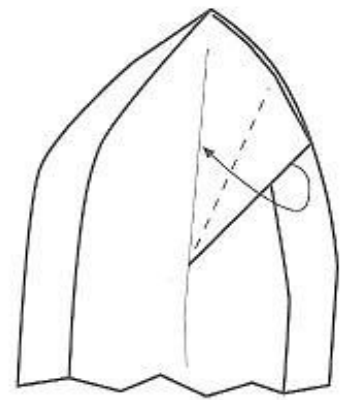

18

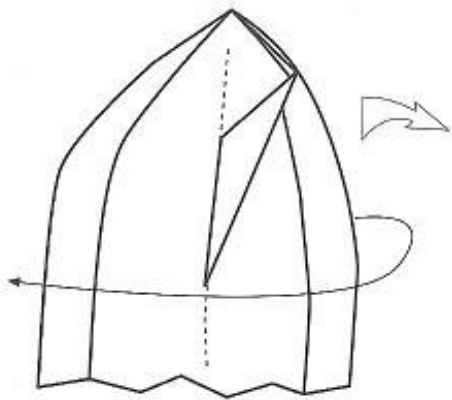

19

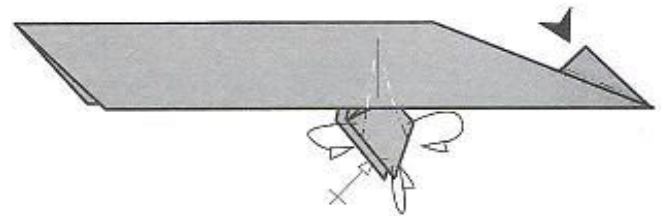

20

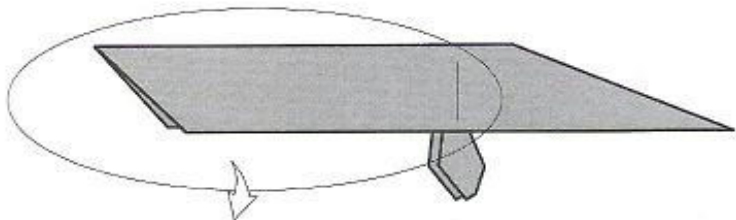

21

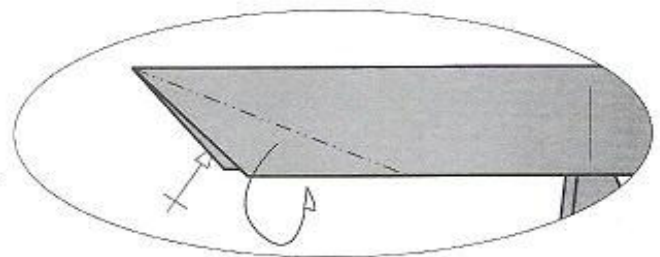

22

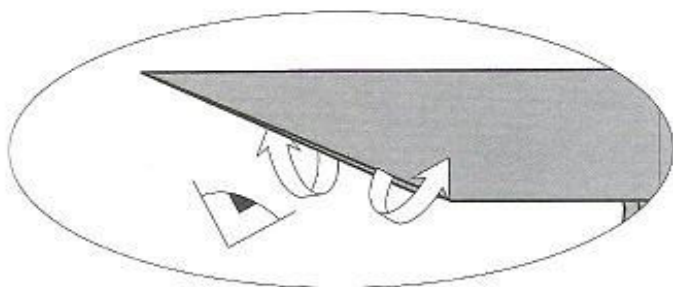

23

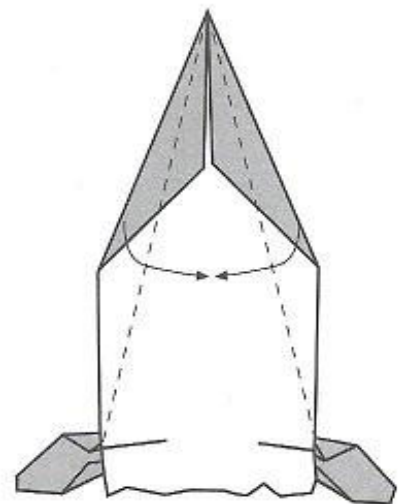

24

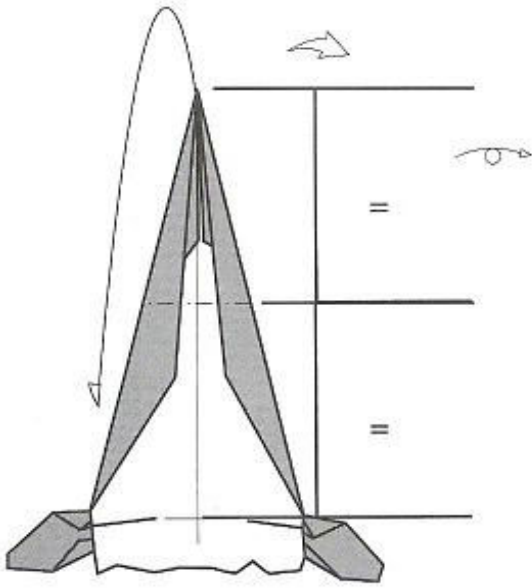

25

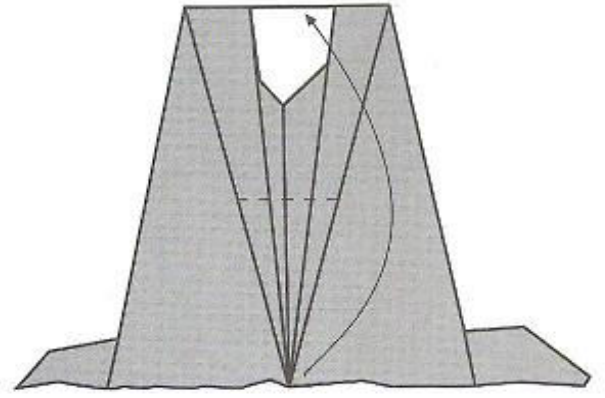

26

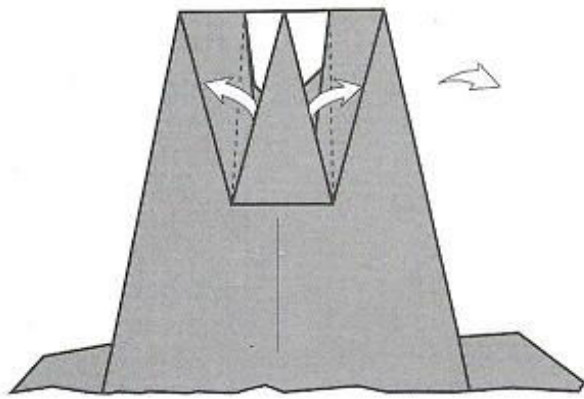

27

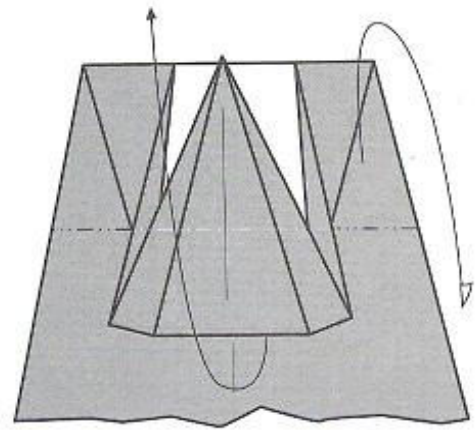

28

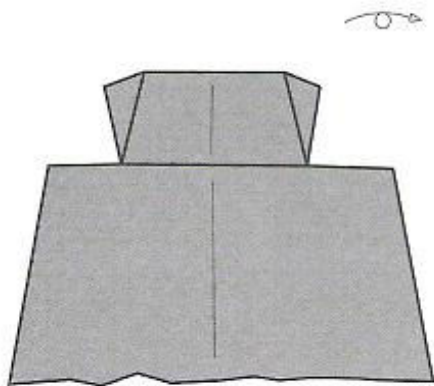

29

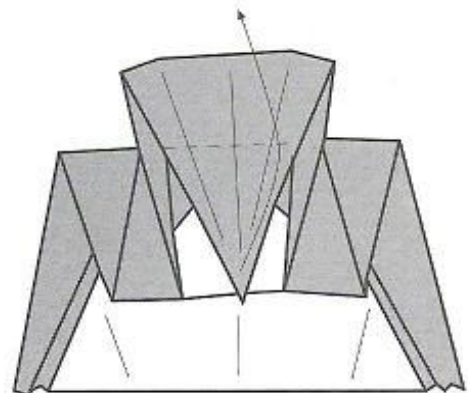

30

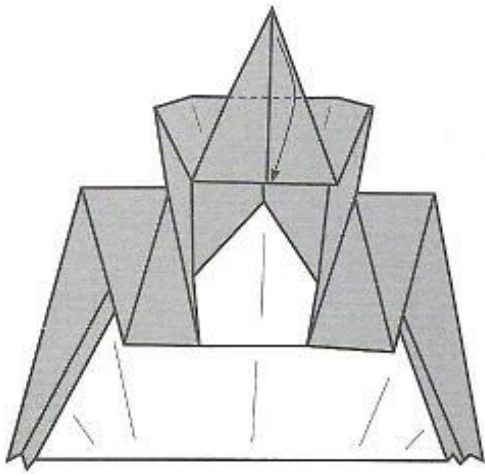

31

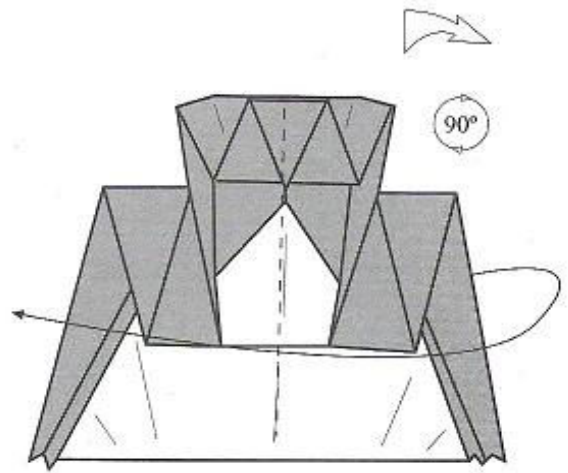

32

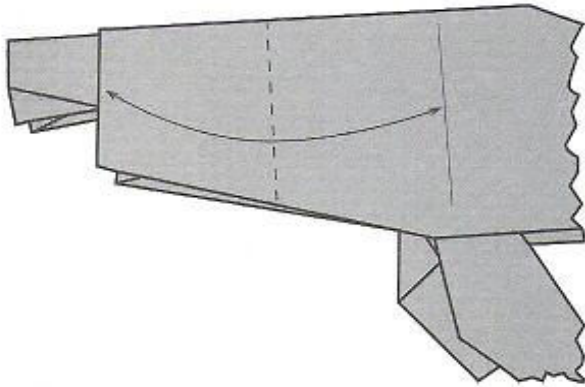

33

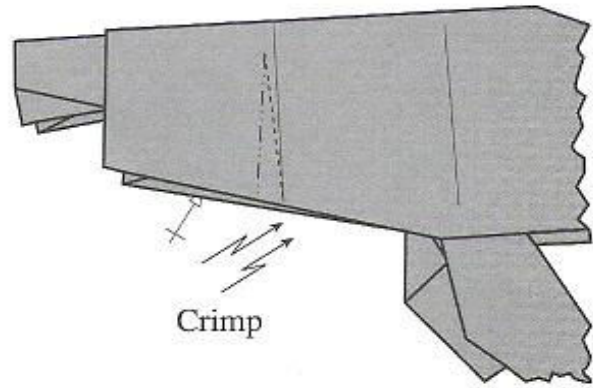

34

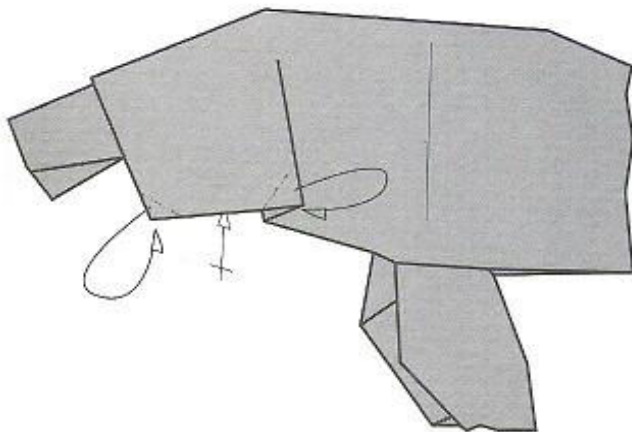

35

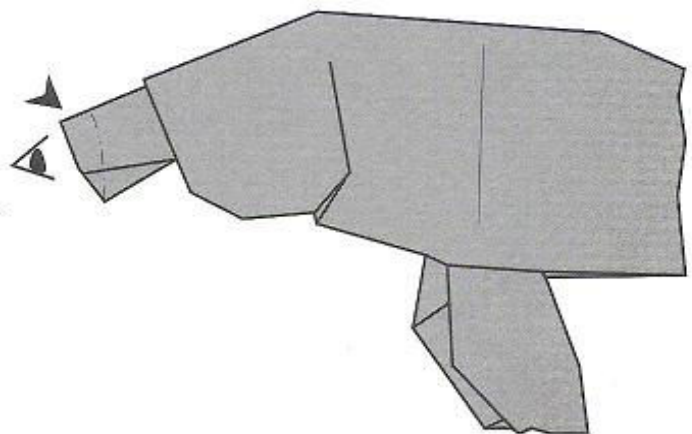

36

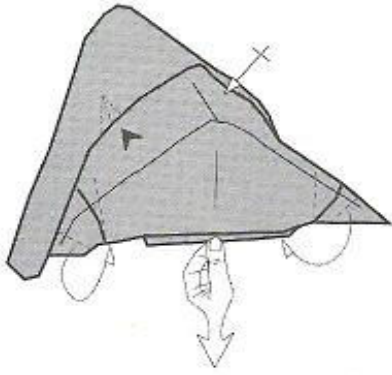

37

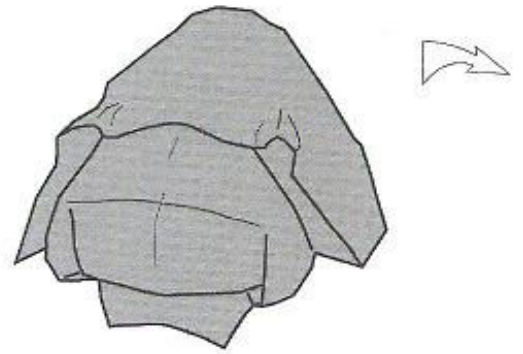

38

▼ 3D effects

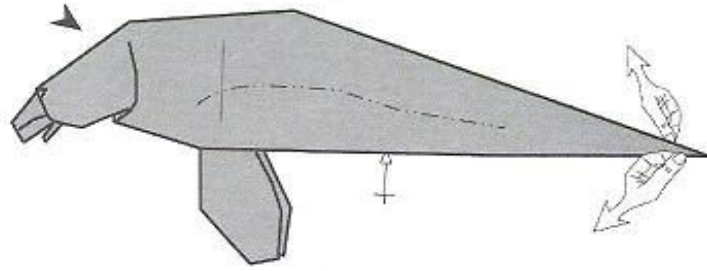

39

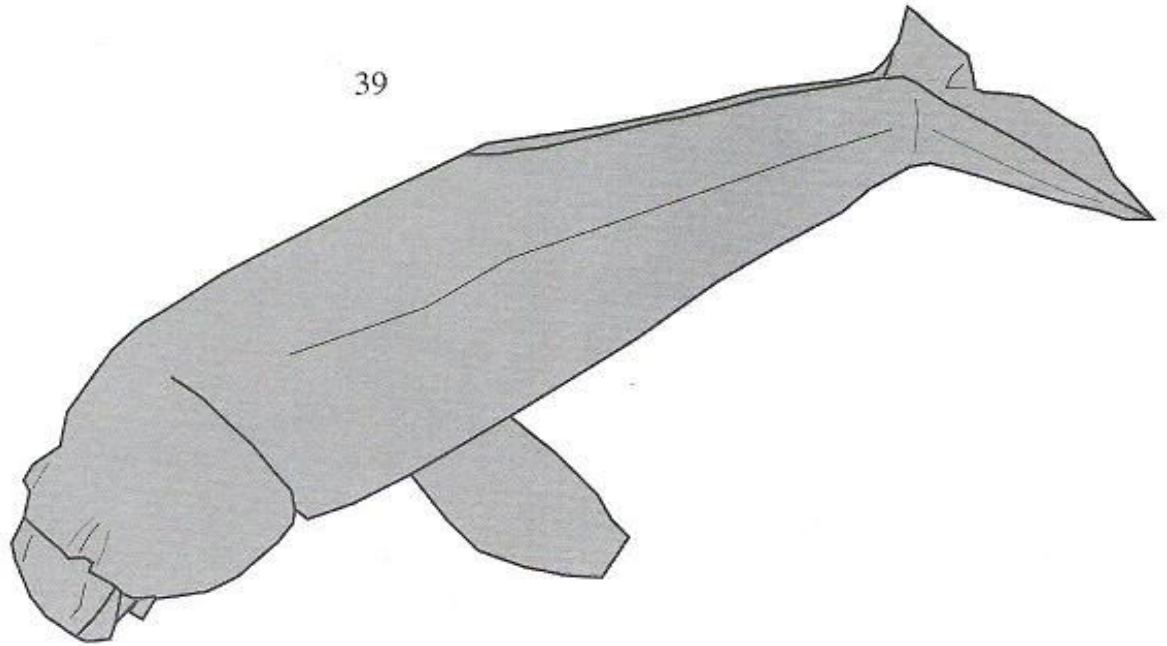

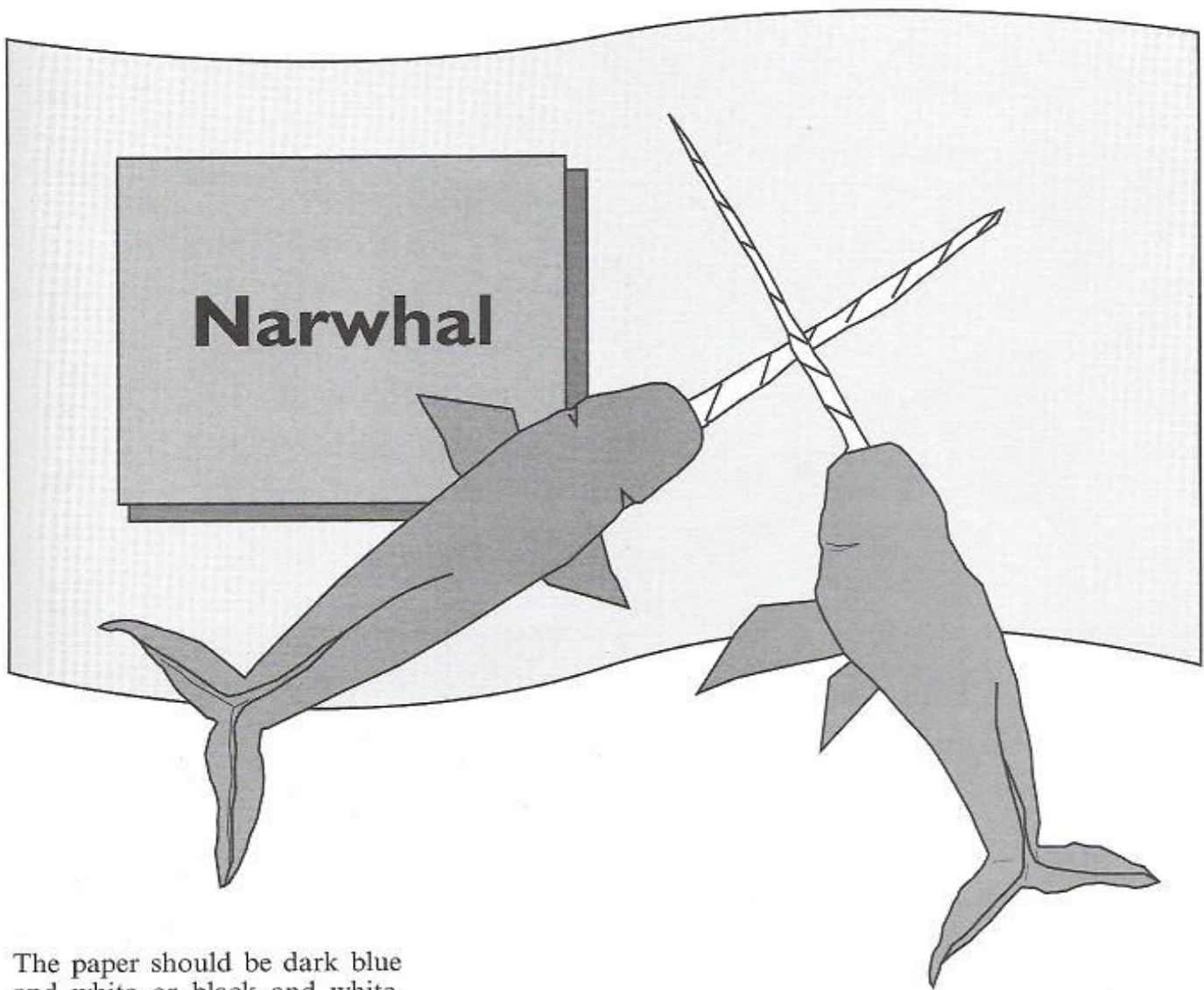

The paper should be dark blue and white or black and white. Any paper type can be used, 120 grams, using the technique of humidified paper.

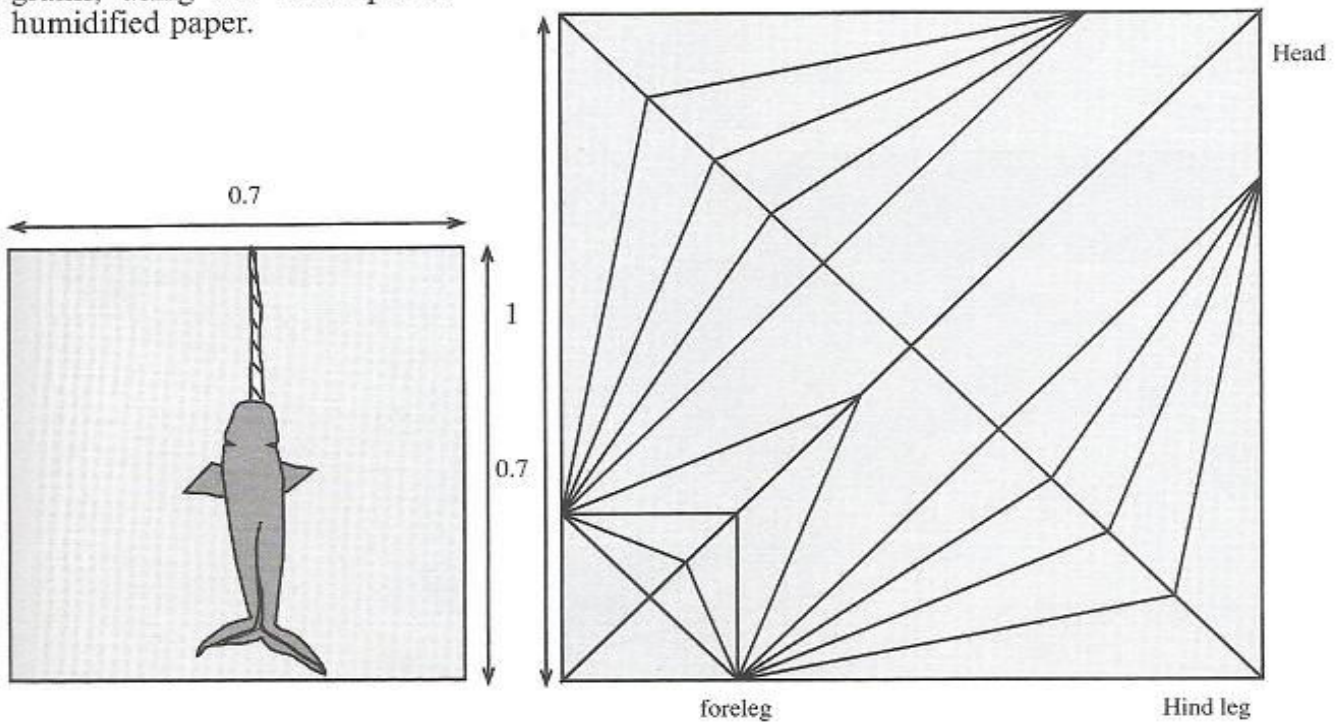

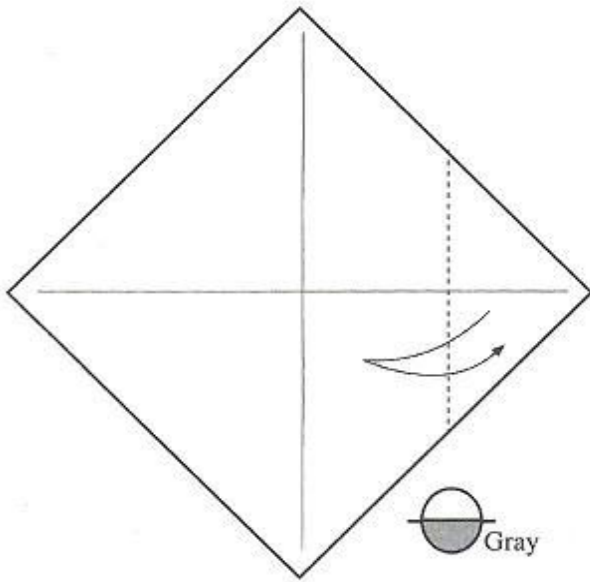

1

Steps 2 until 19 of dugong

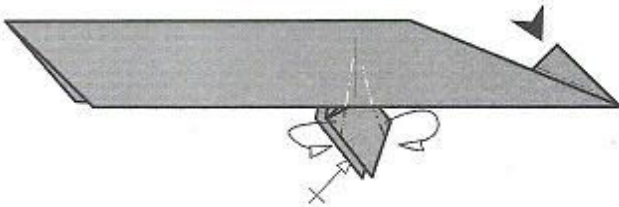

20

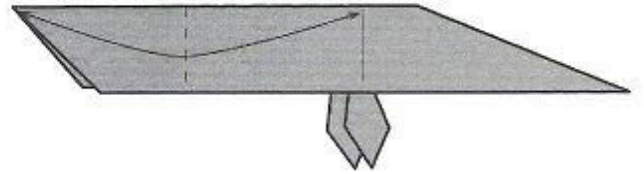

21

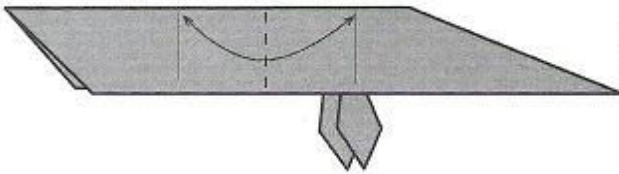

22

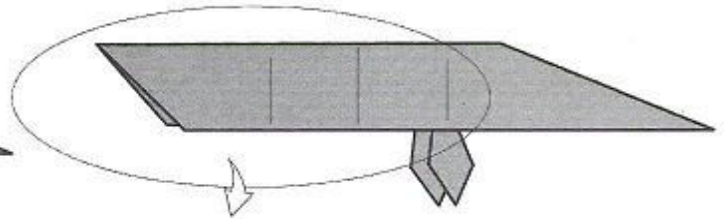

23

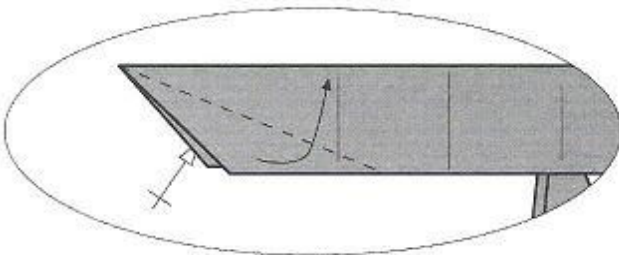

24

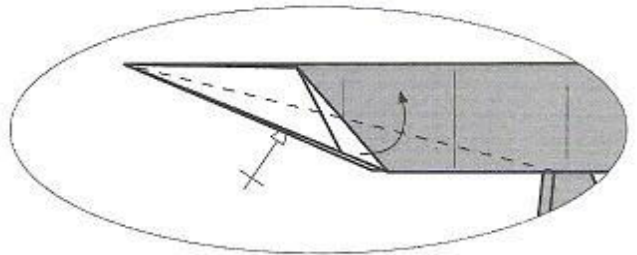

25

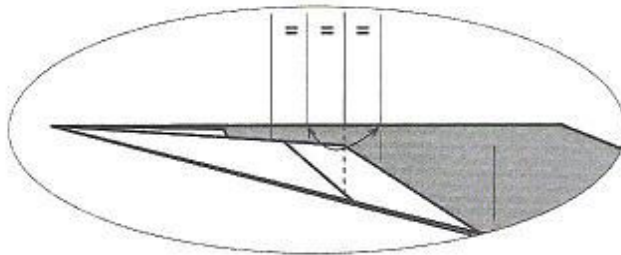

26

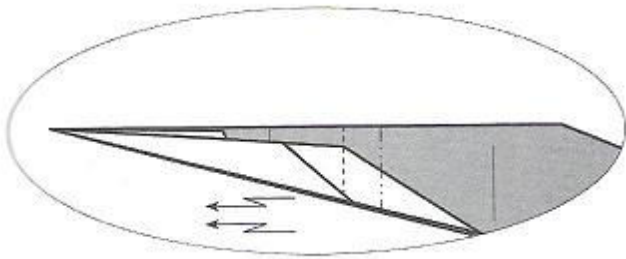

27

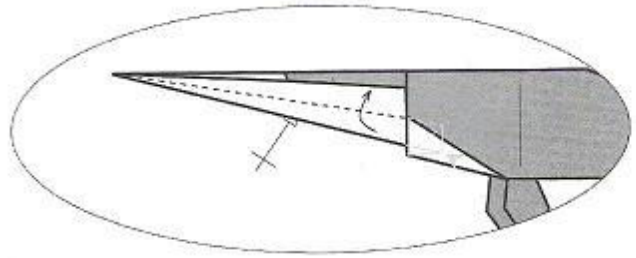

28

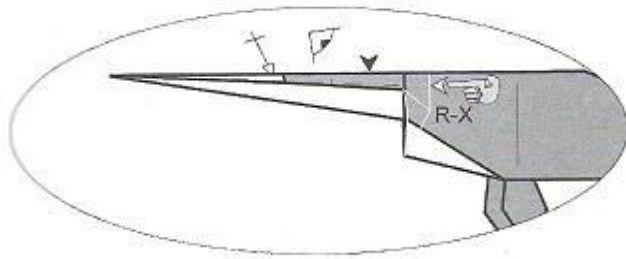

29

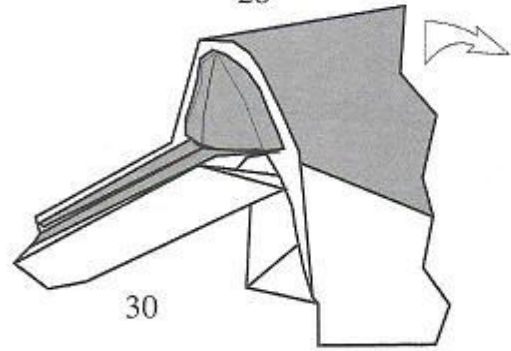

30

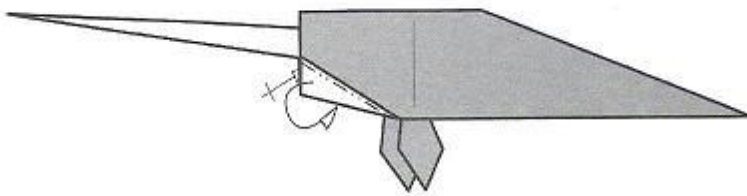

31

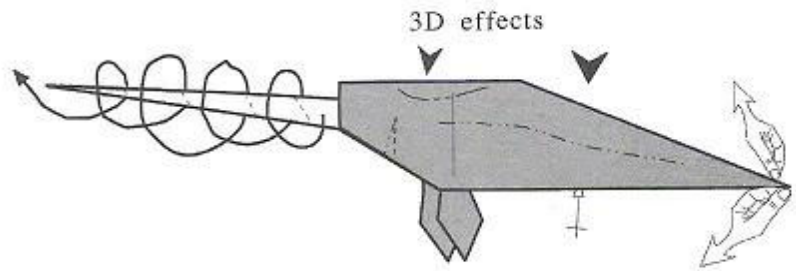

32

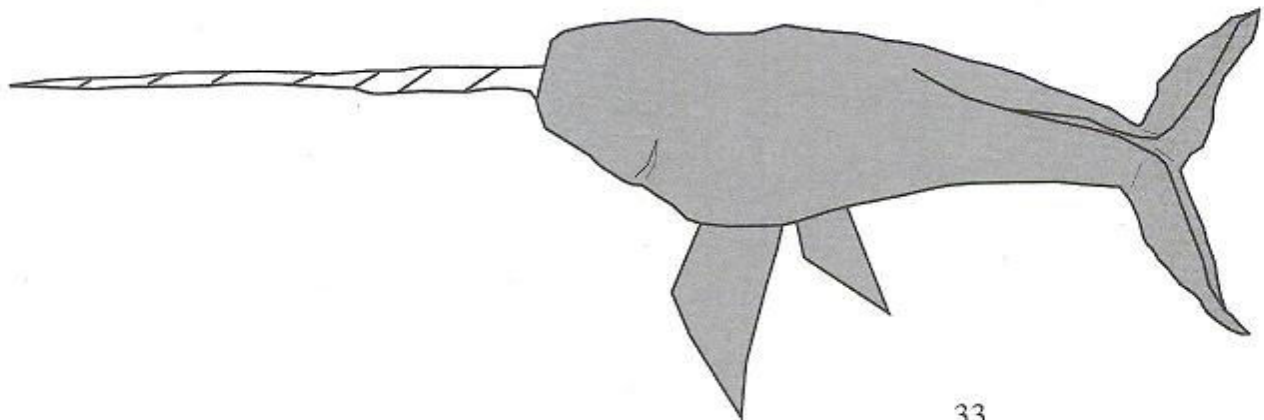

33

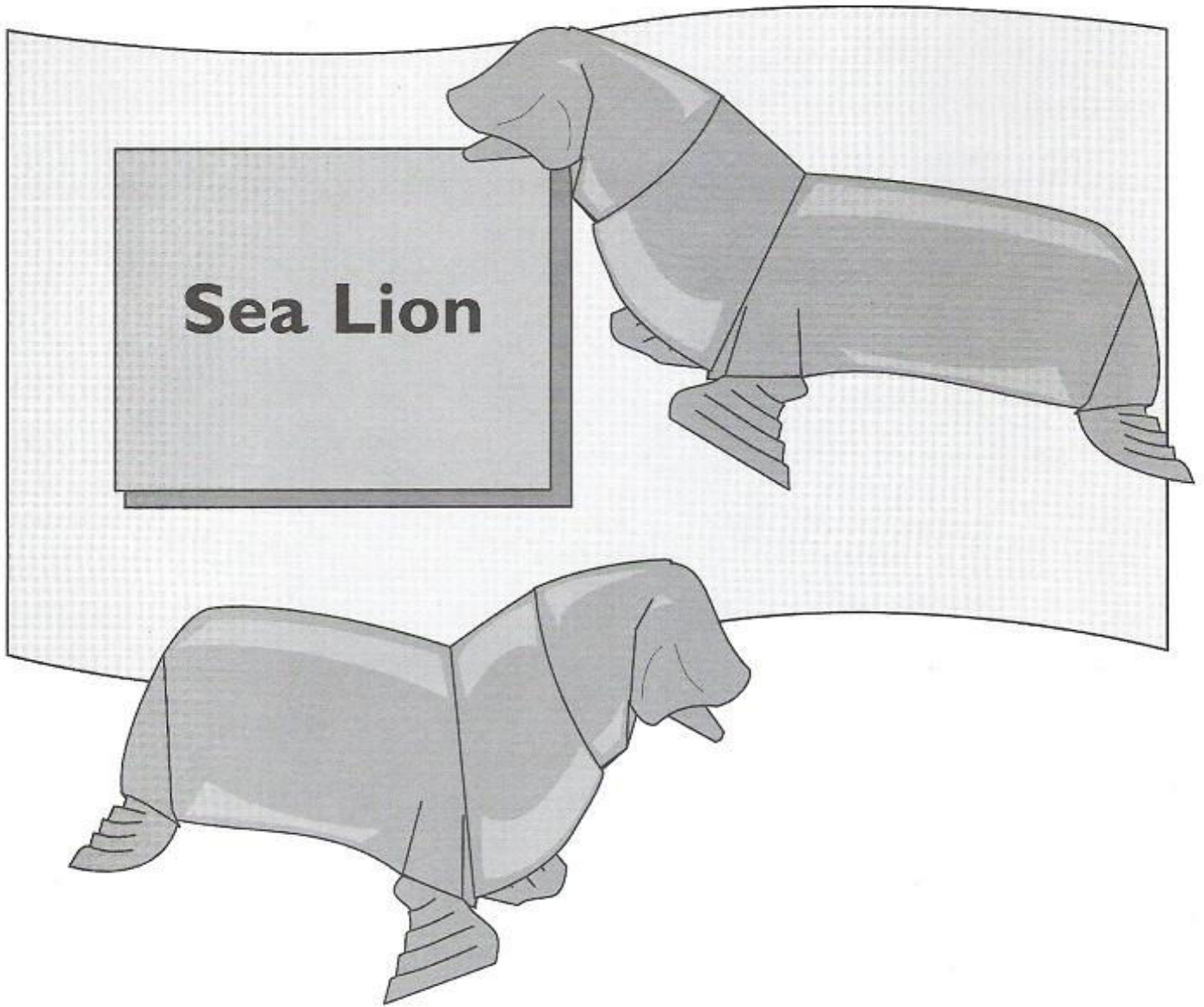

The paper should be brown.
 Any paper type can be used,
 120 grams, using the technique
 of humidified paper.

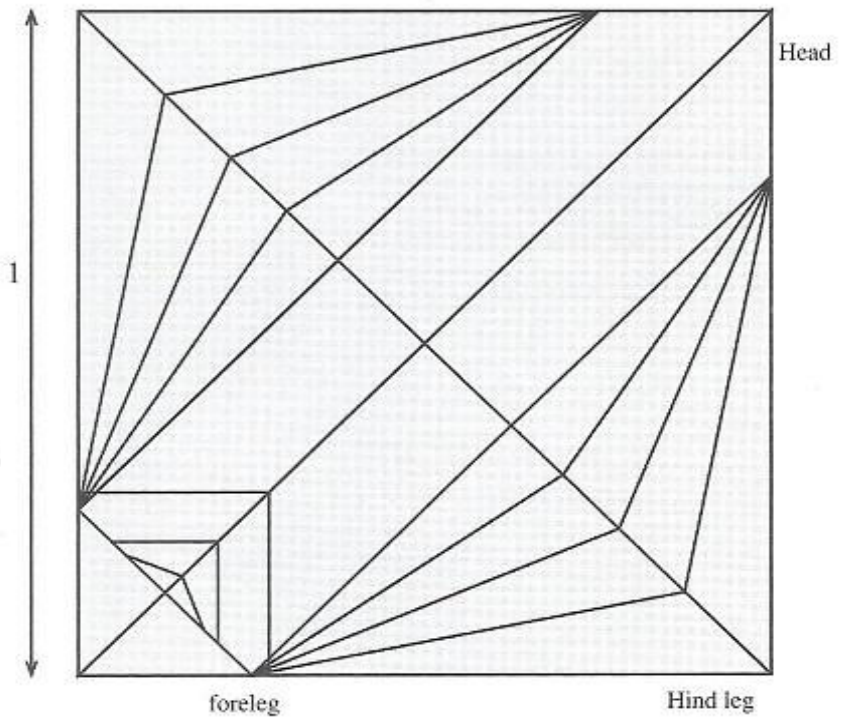
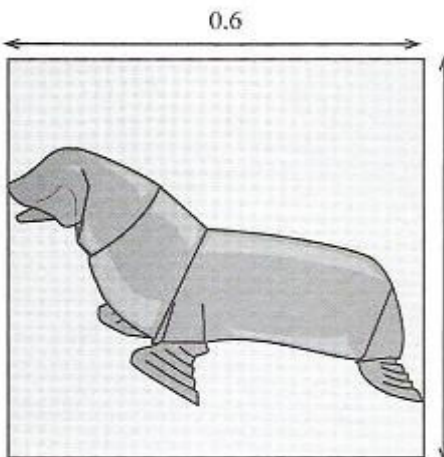

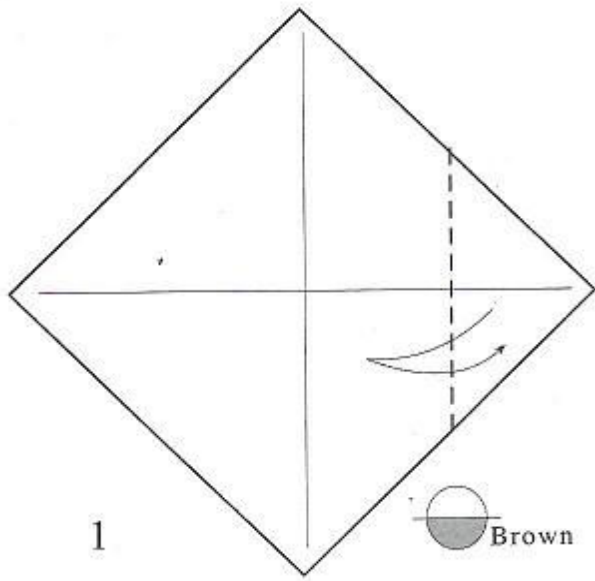

Steps 2 until 13 of dugong

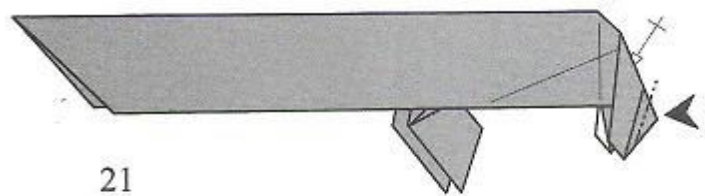
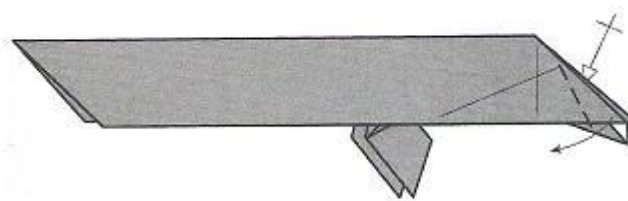
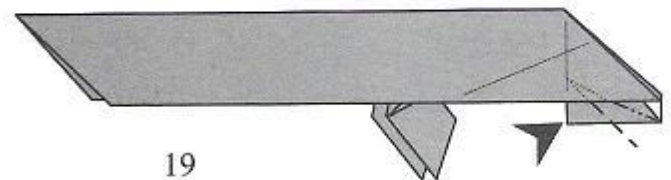
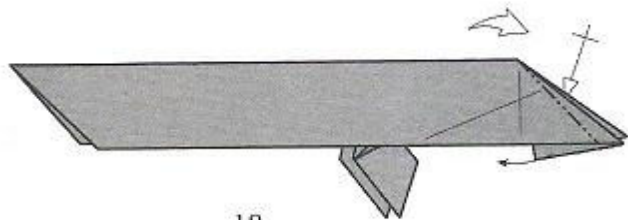
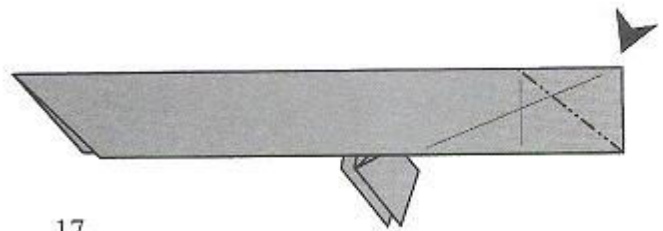
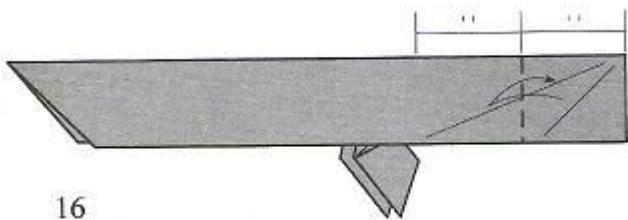
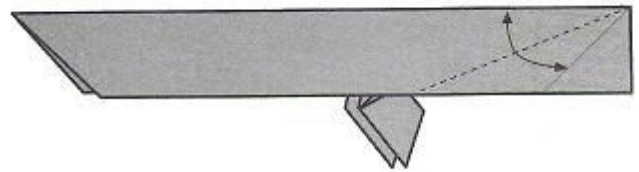
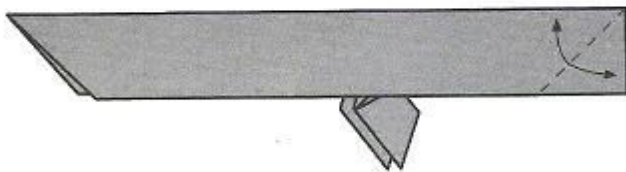

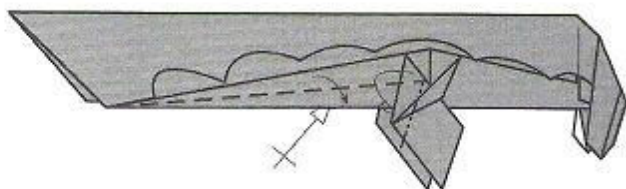

22

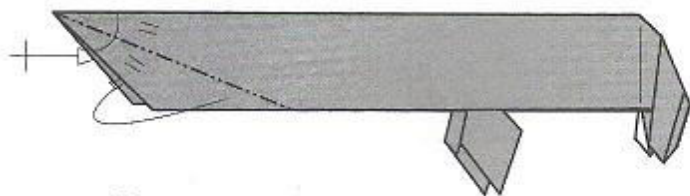

23

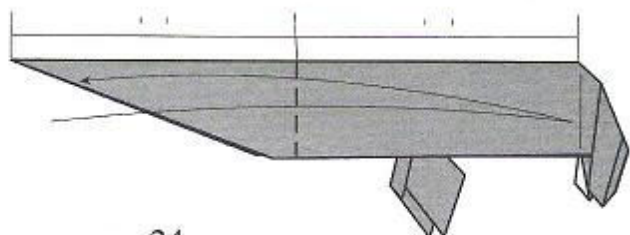

24

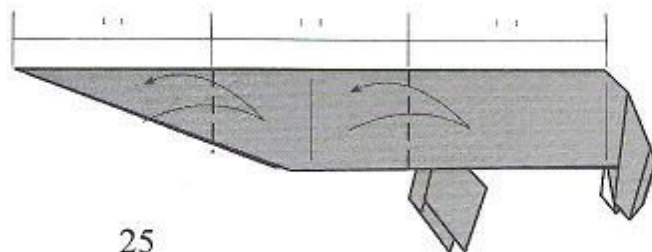

25

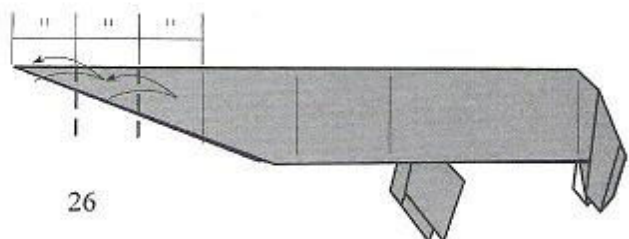

26

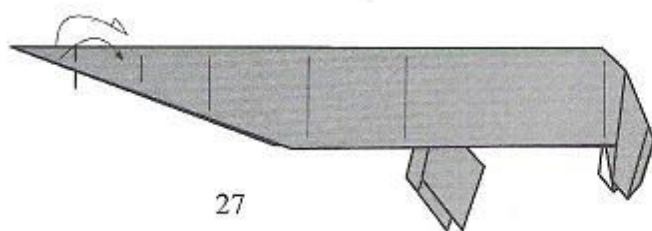

27

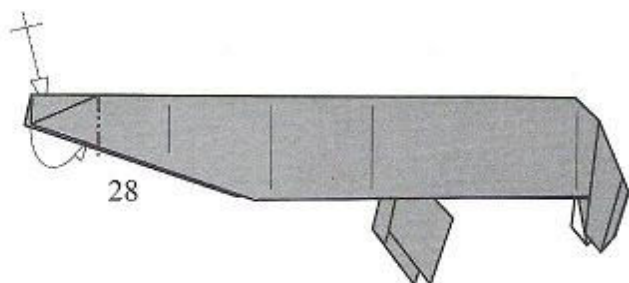

28

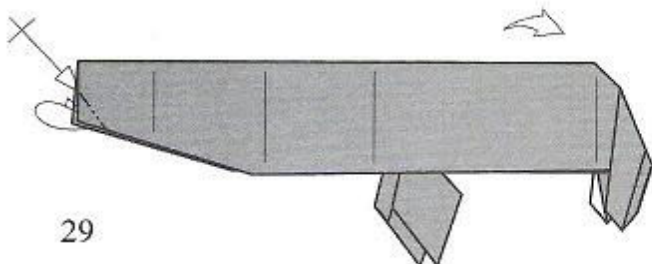

29

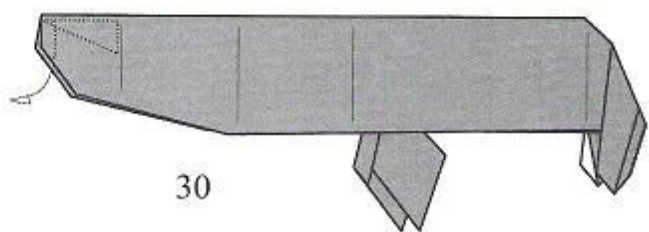

30

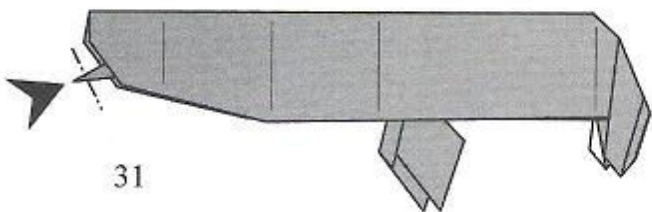

31

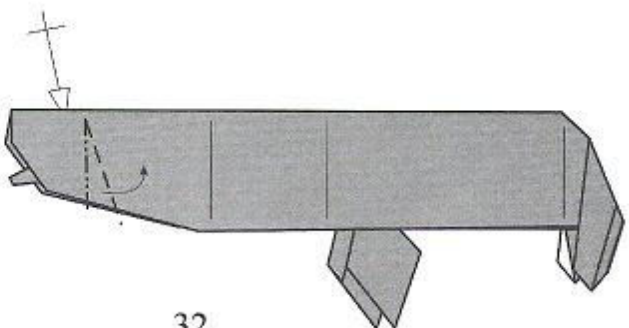

32

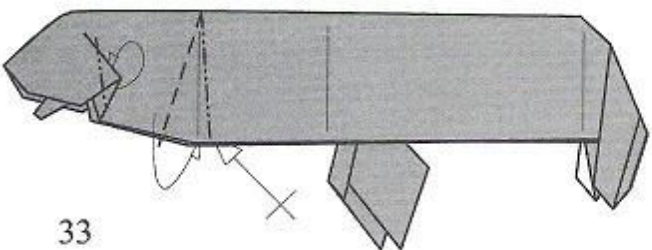

33

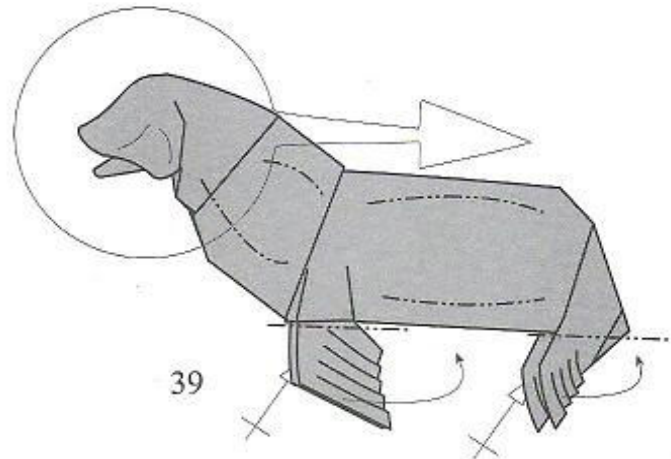
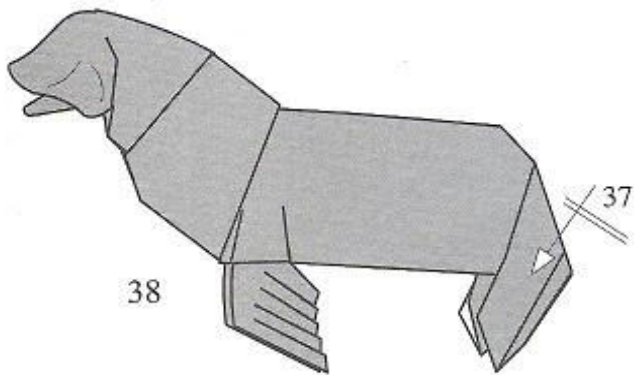
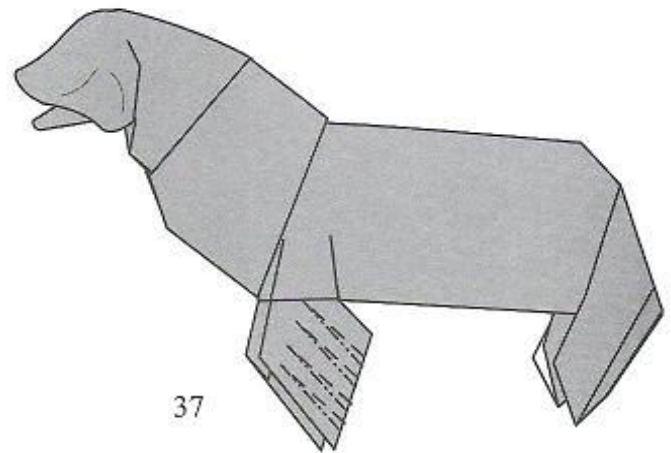
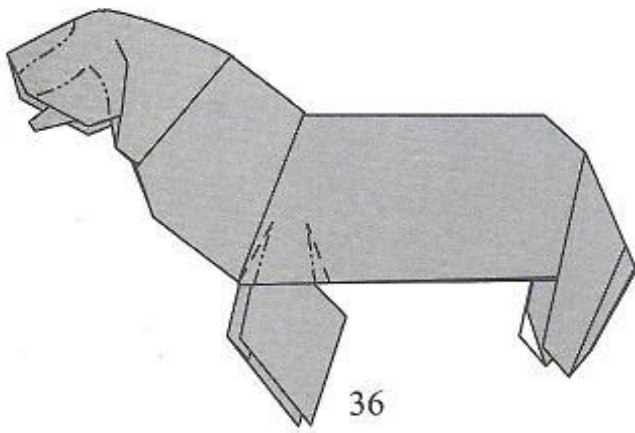
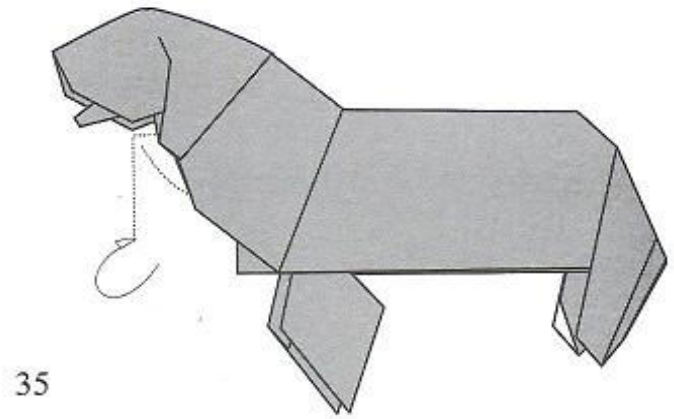
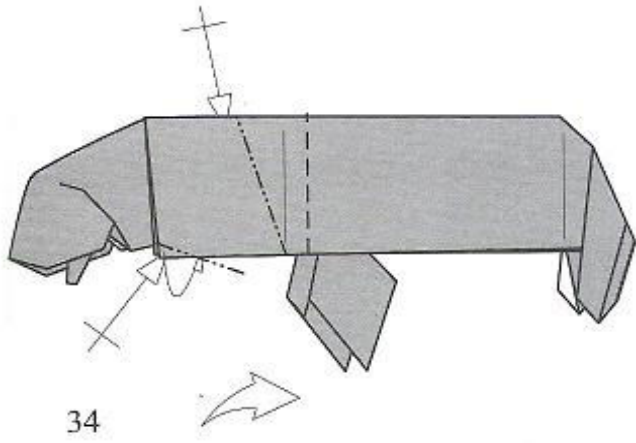

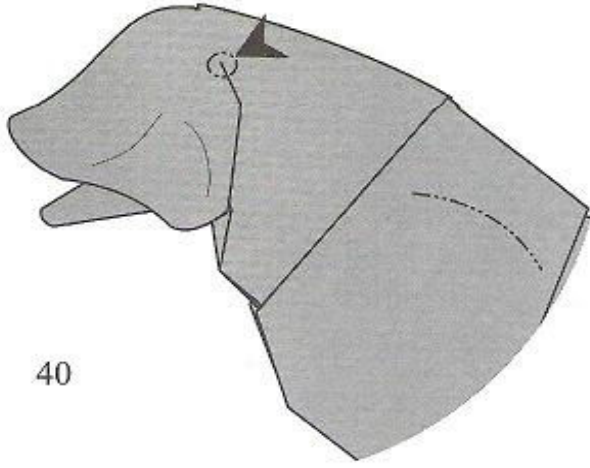

40

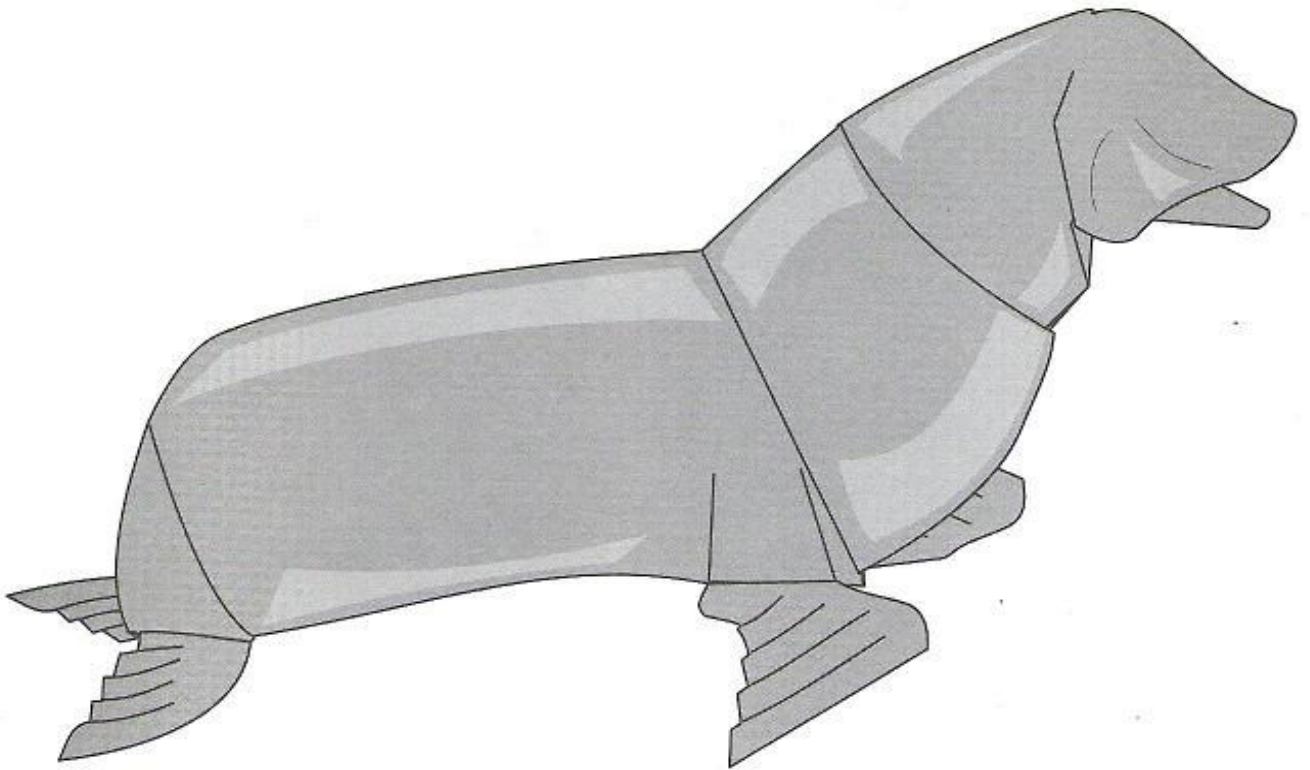

41

Black Widow

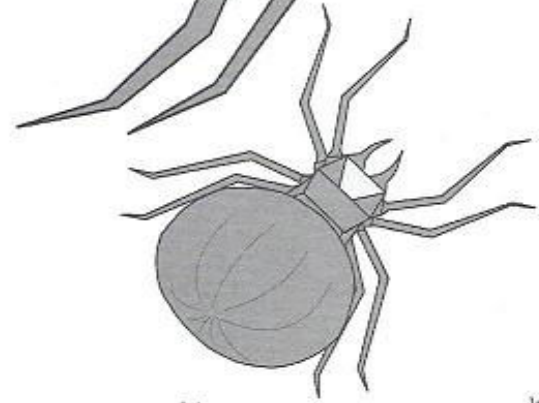
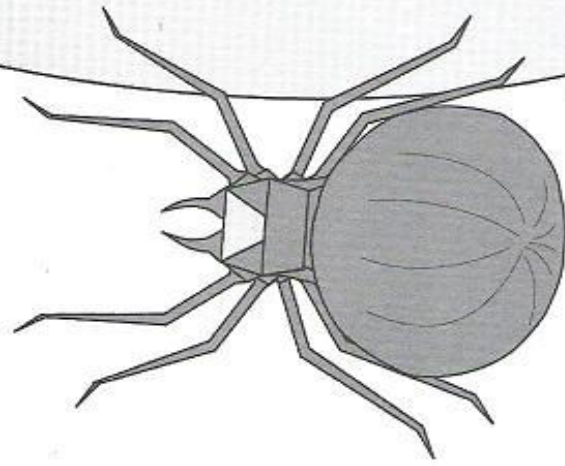
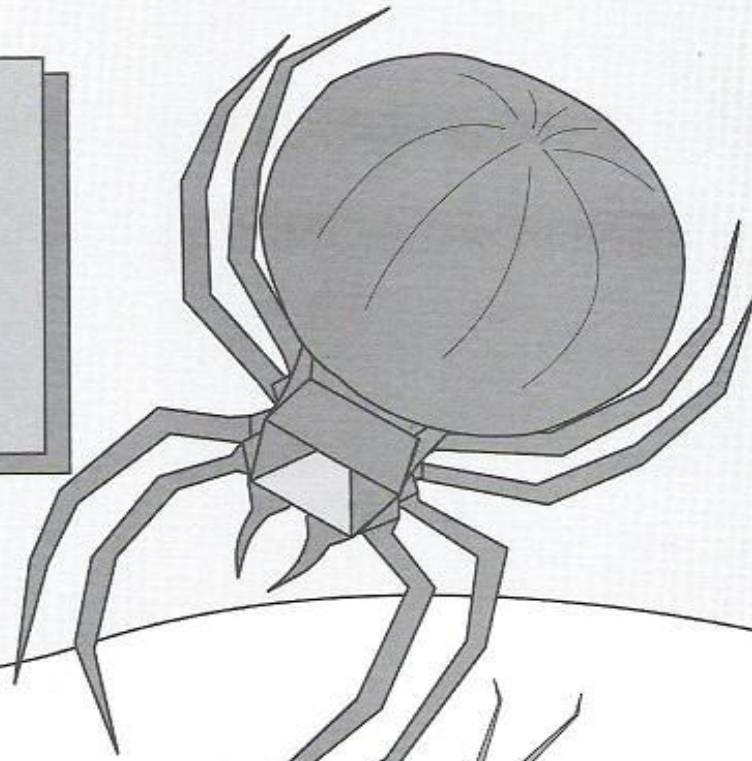

The paper should be black and red. Fine paper is recommended, less than 40 grams, double silk, or "sandwich" of 5.9x5.9 inches (15x15 cm) or bigger.

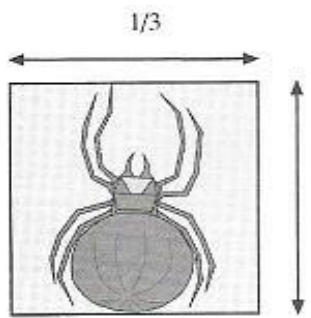
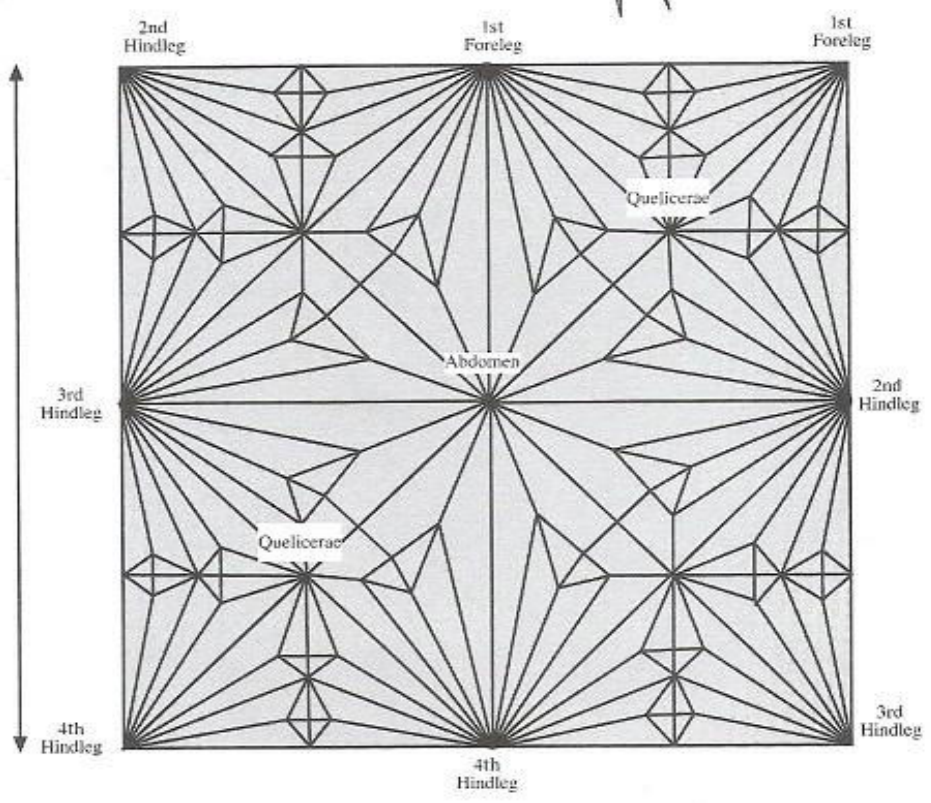

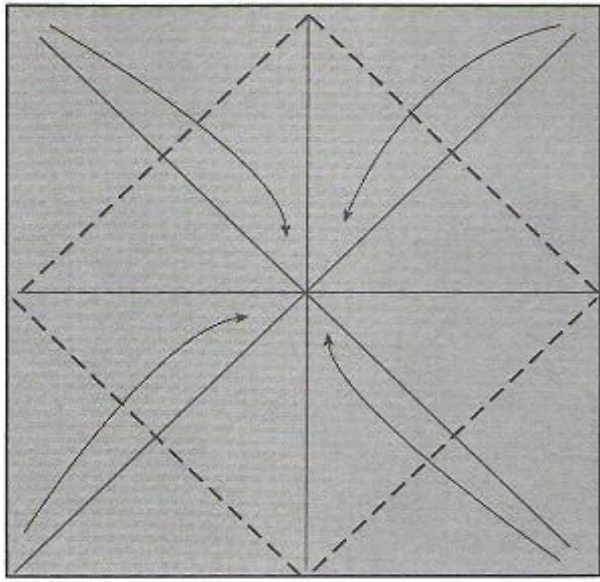

1

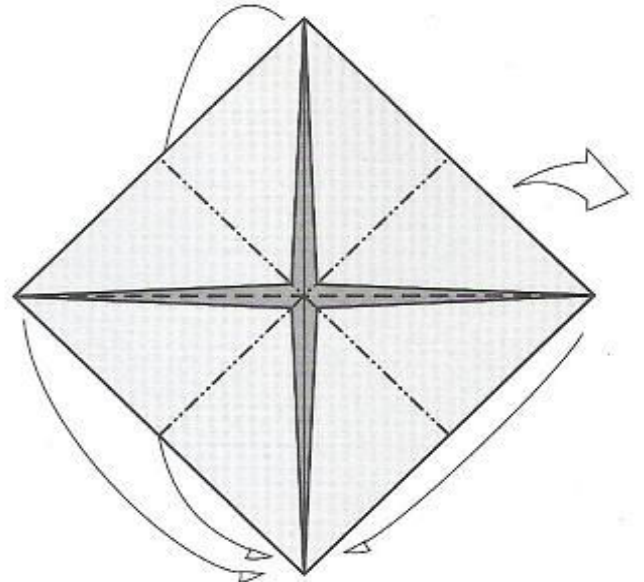

2

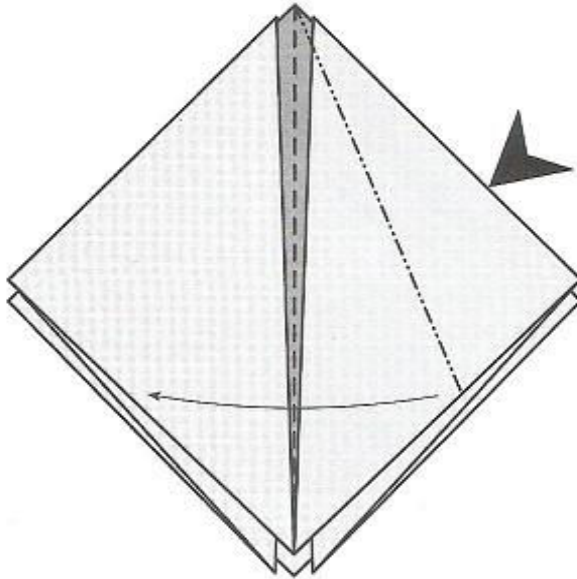

3

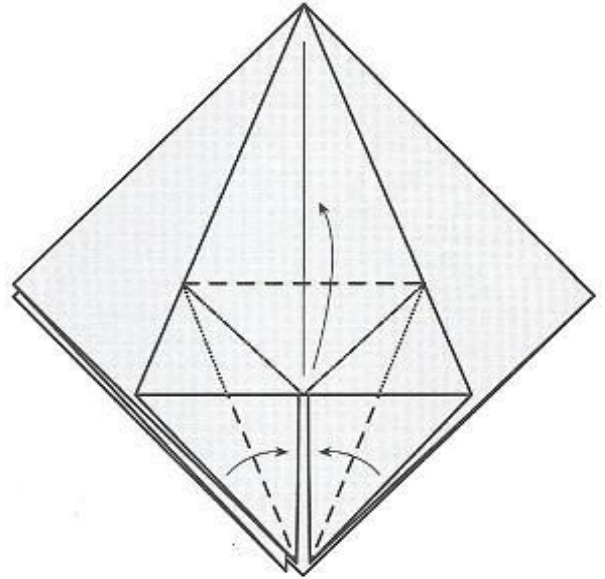

4

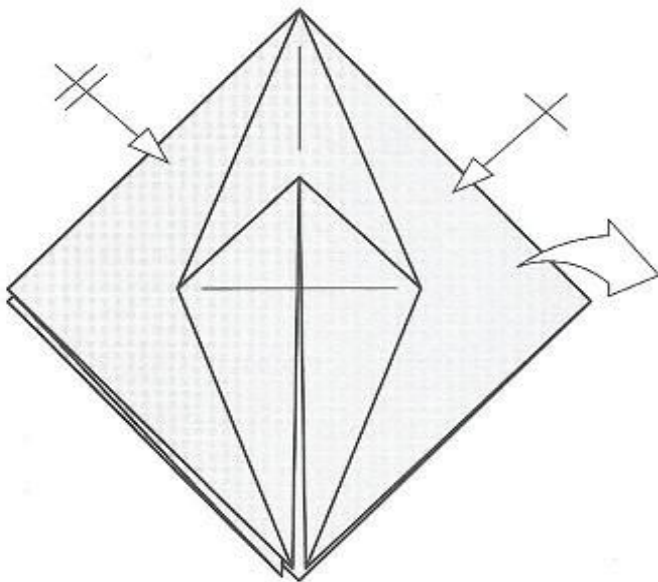

5

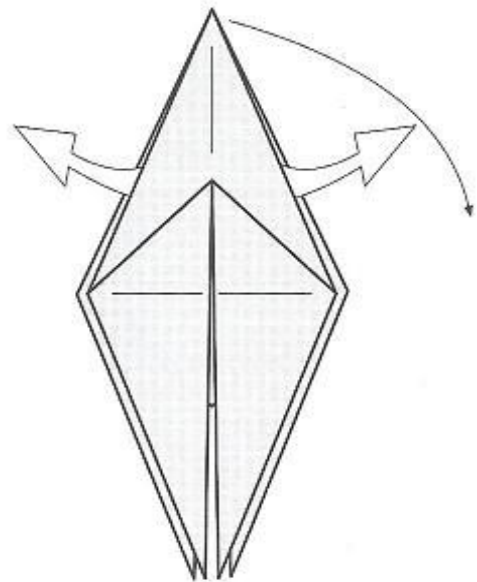

6

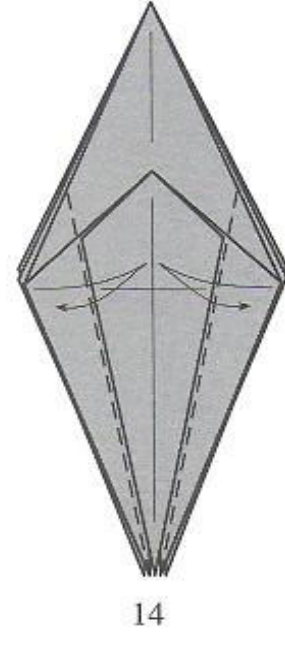
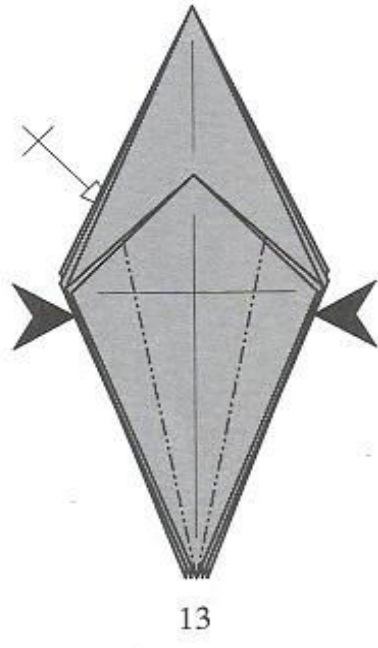
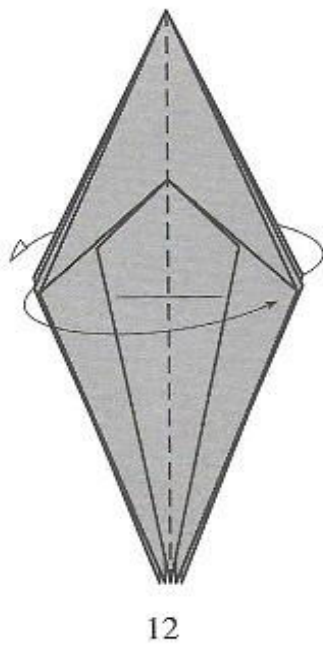
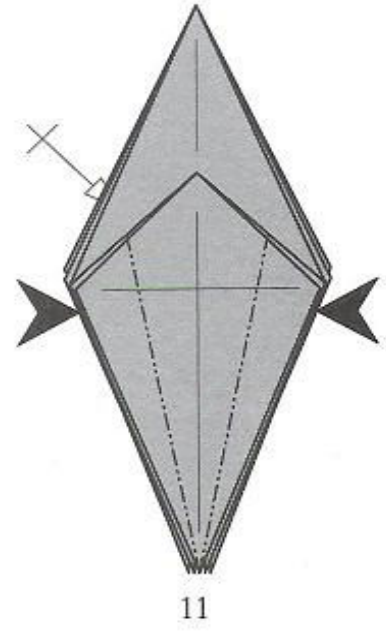
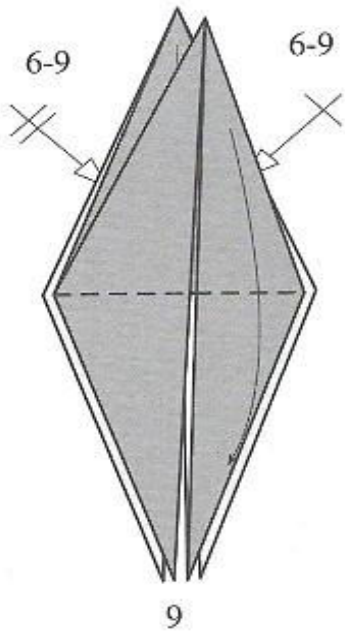
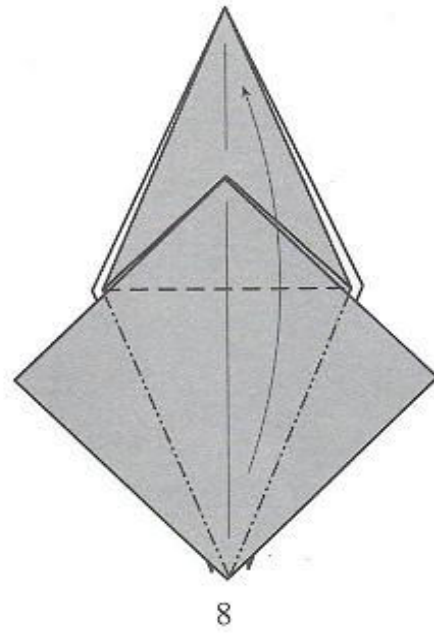
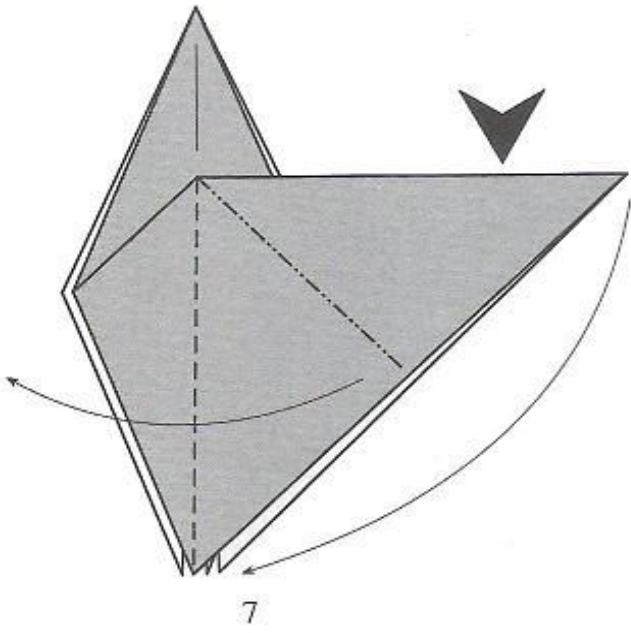

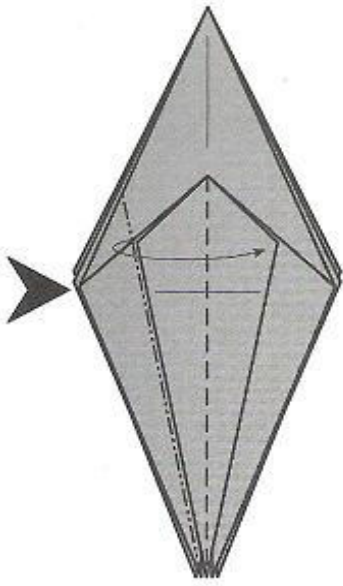

15

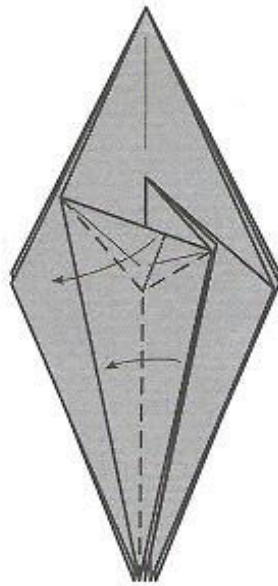

16

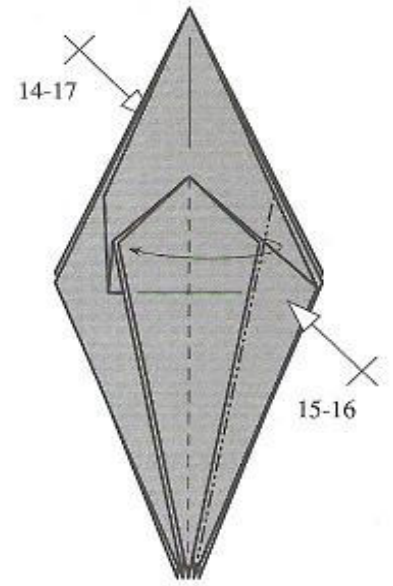

17

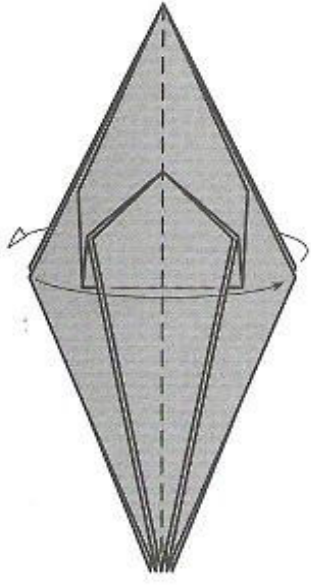

18

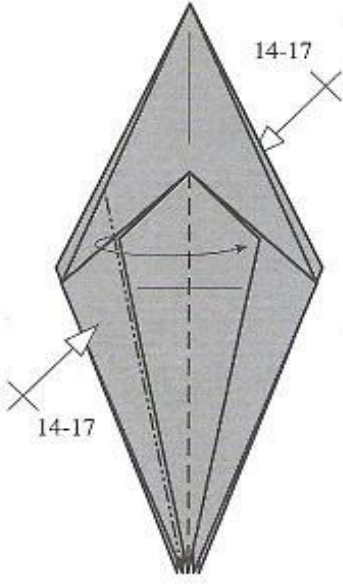

19

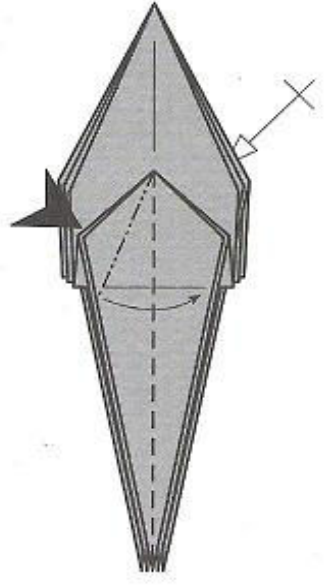

20

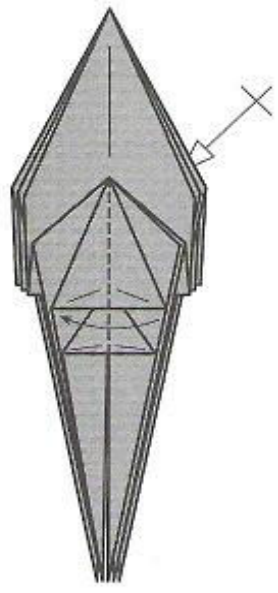

21

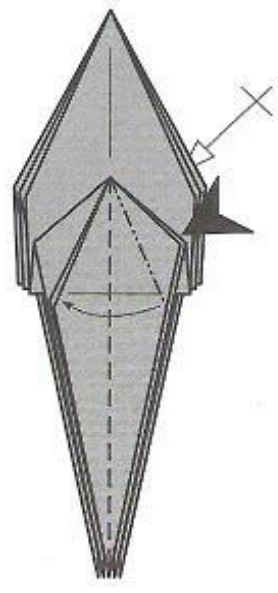

22

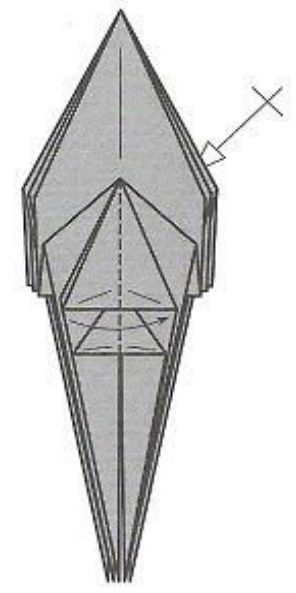

23

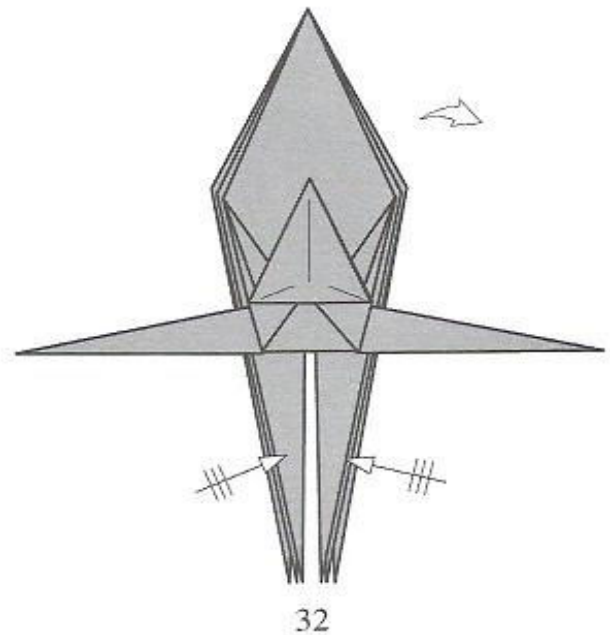
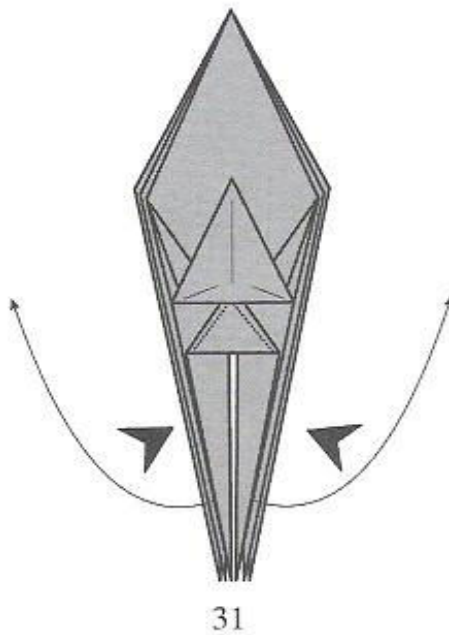
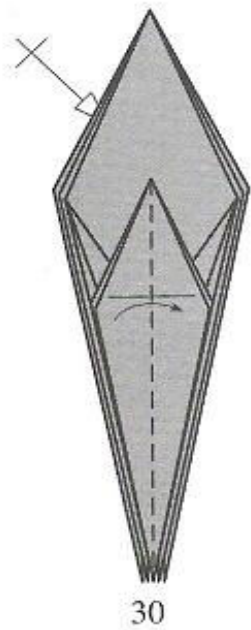
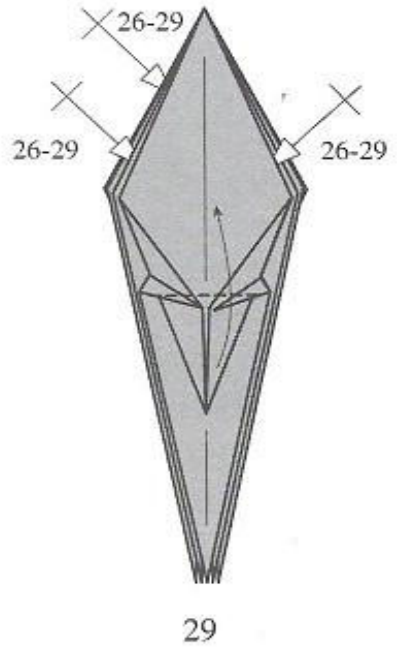
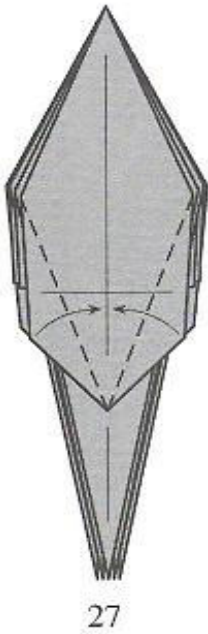
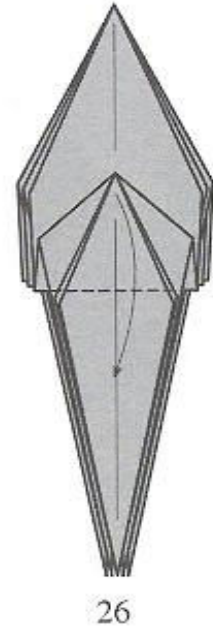
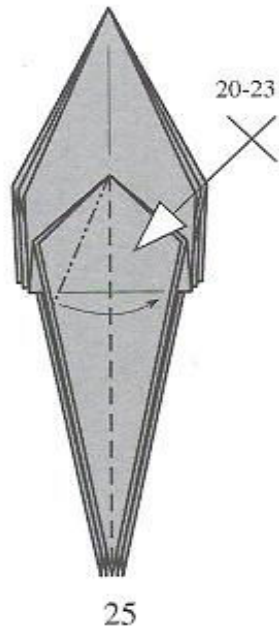
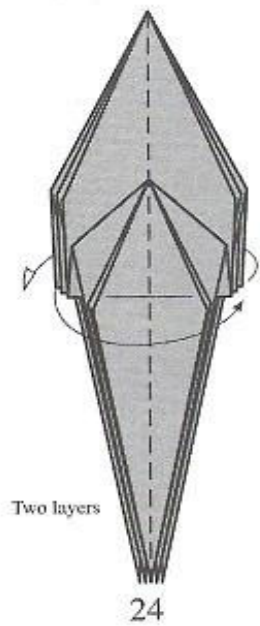

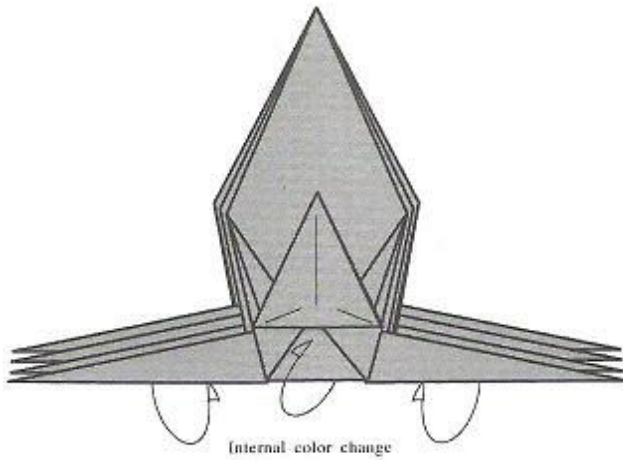

33

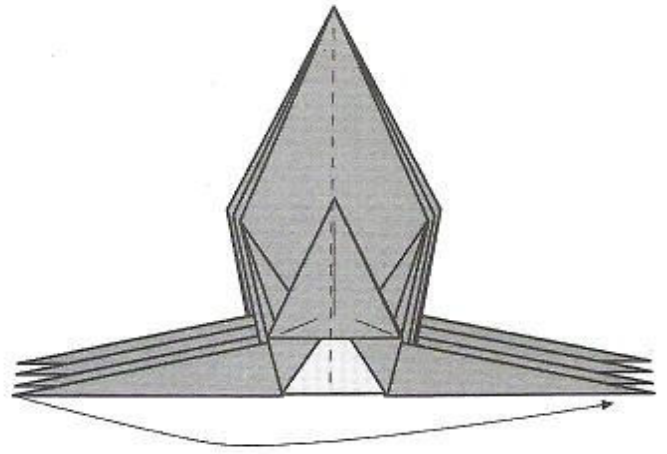

34

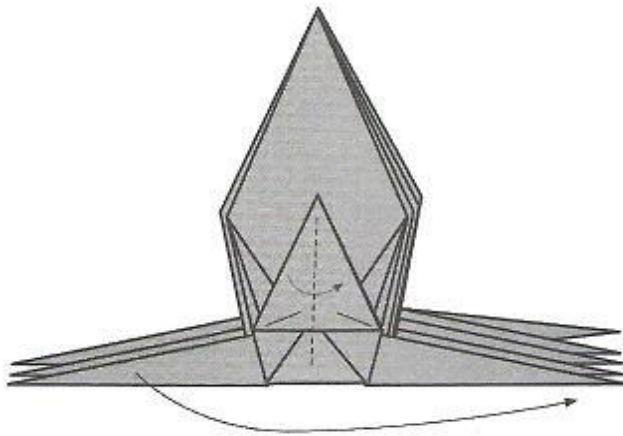

35

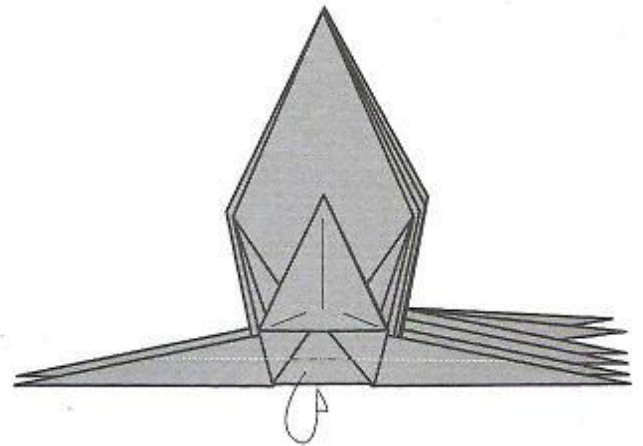

36

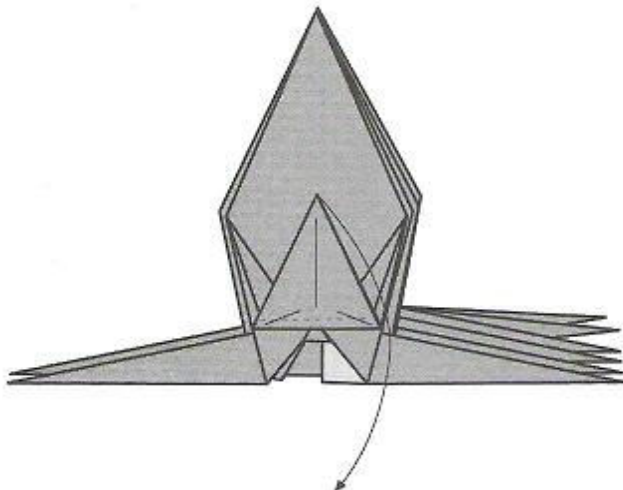

37

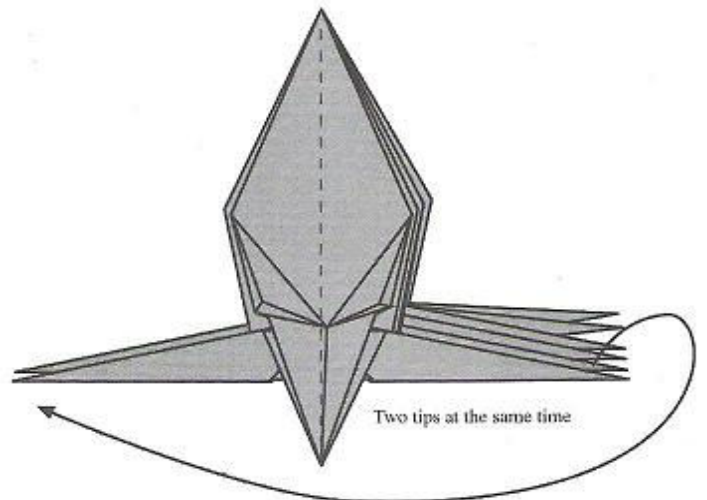

38

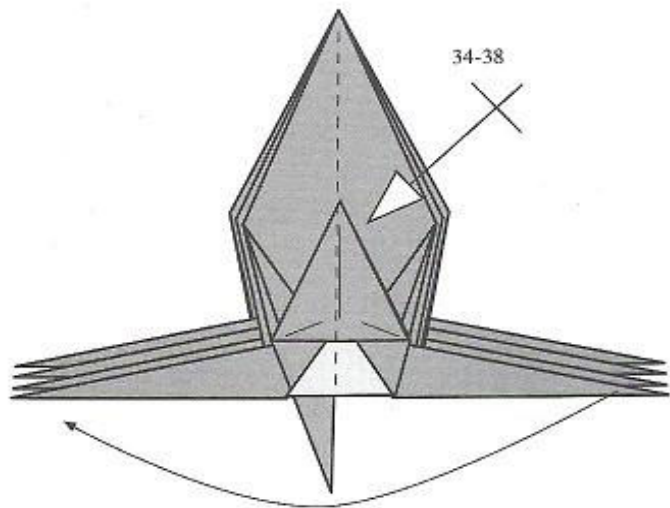

39

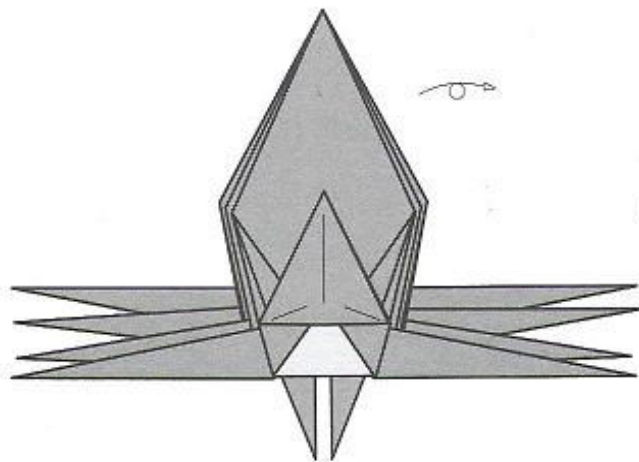

40

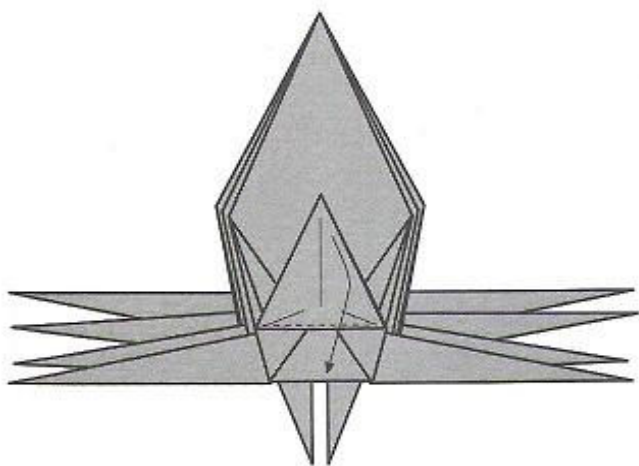

41

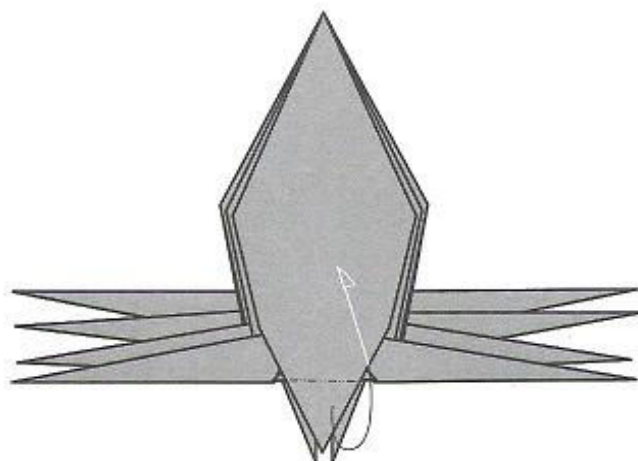

42

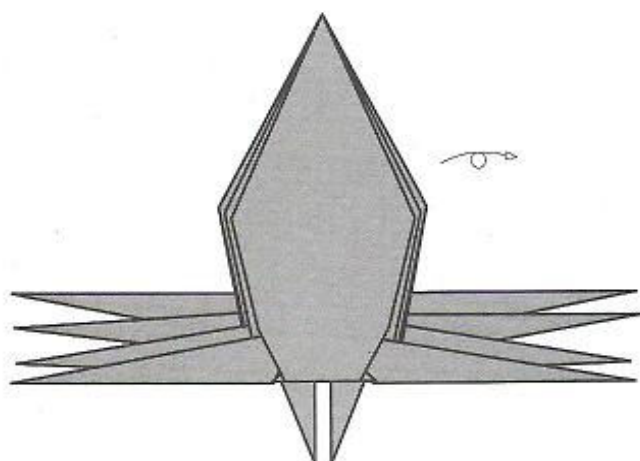

43

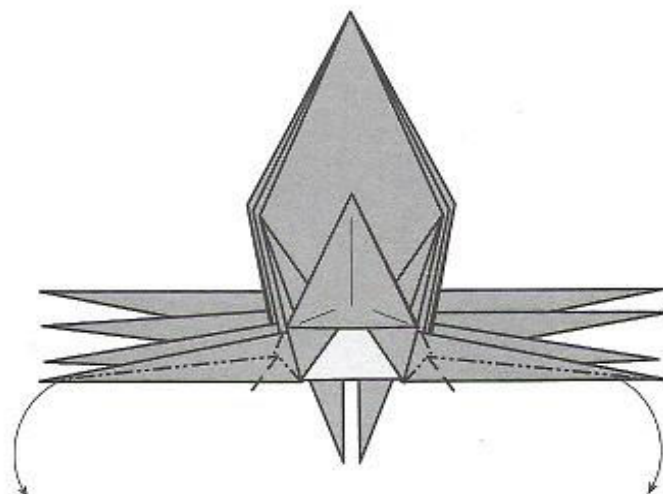

44

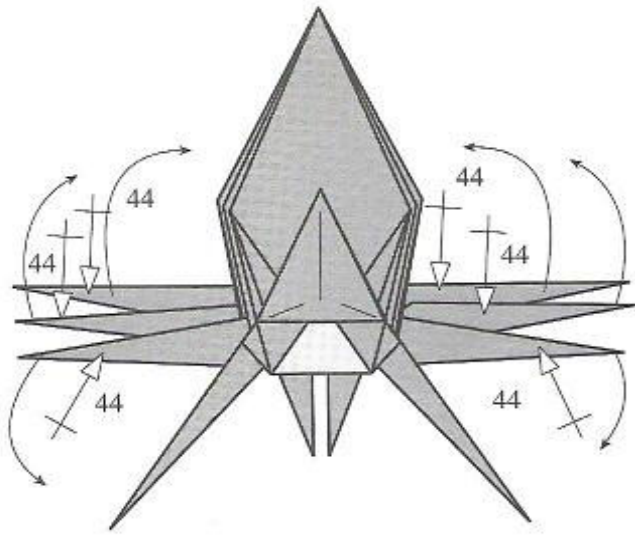

45

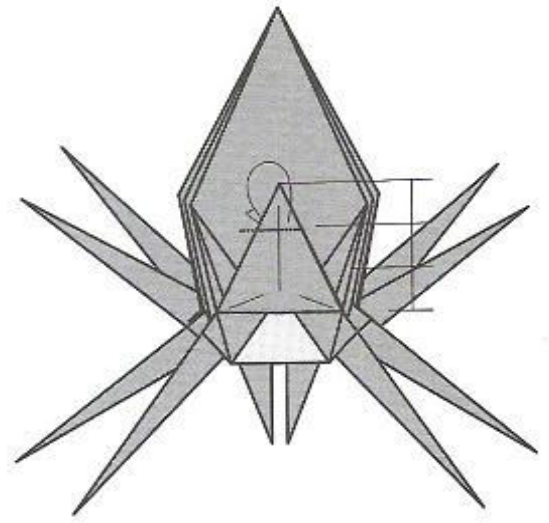

46

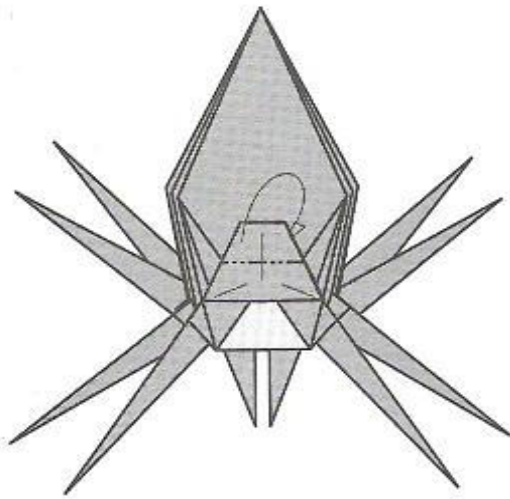

47

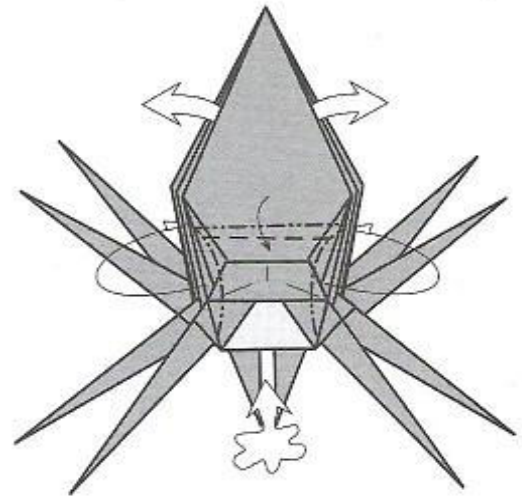

48

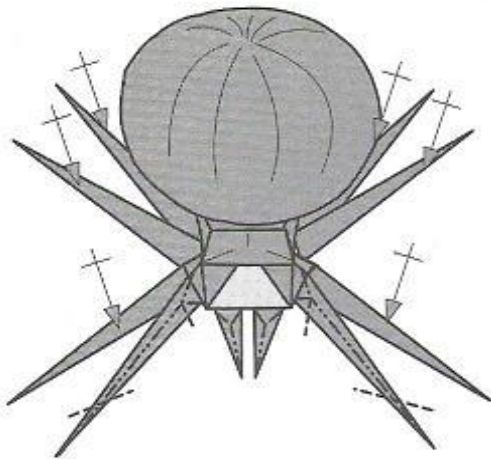

49

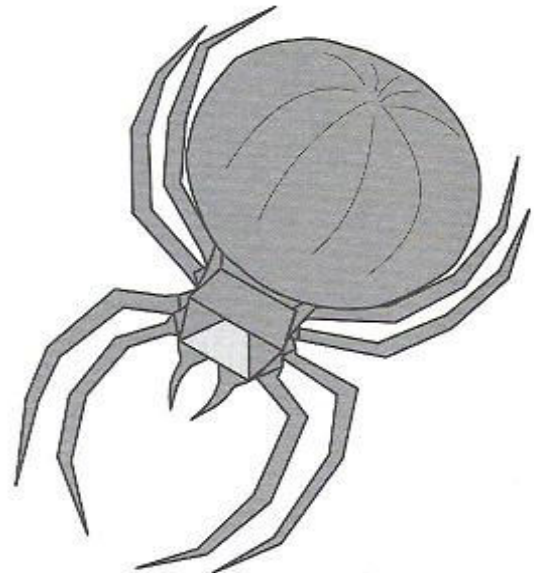

50

**Harvestman
(Phalangium)**

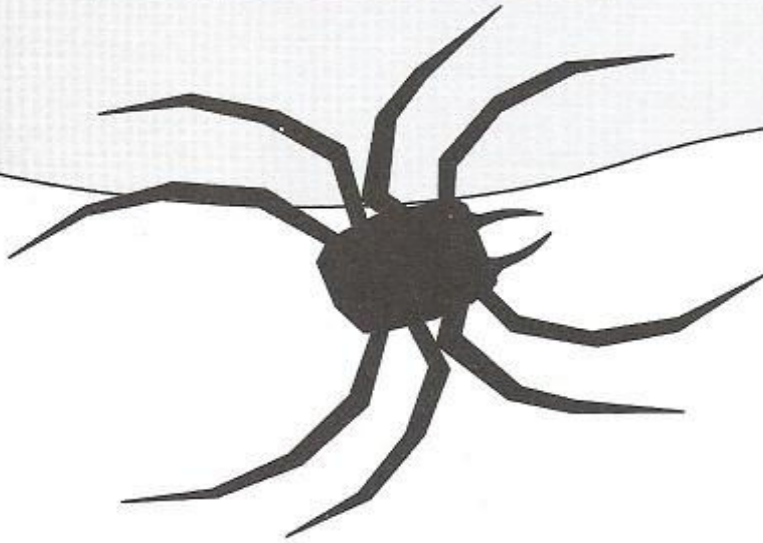
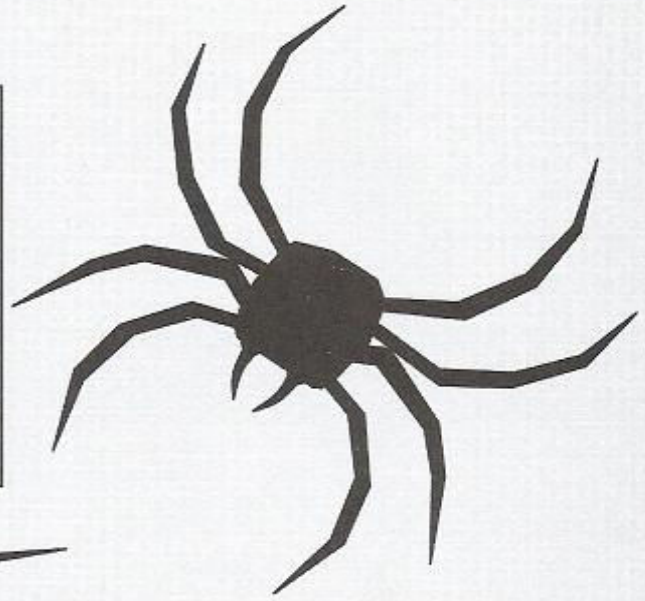

The paper should be black. Fine paper is recommended, less than 30 grams, double silk, or “sandwich” of 7.9x7.9 inches (20x20 cm) or bigger.

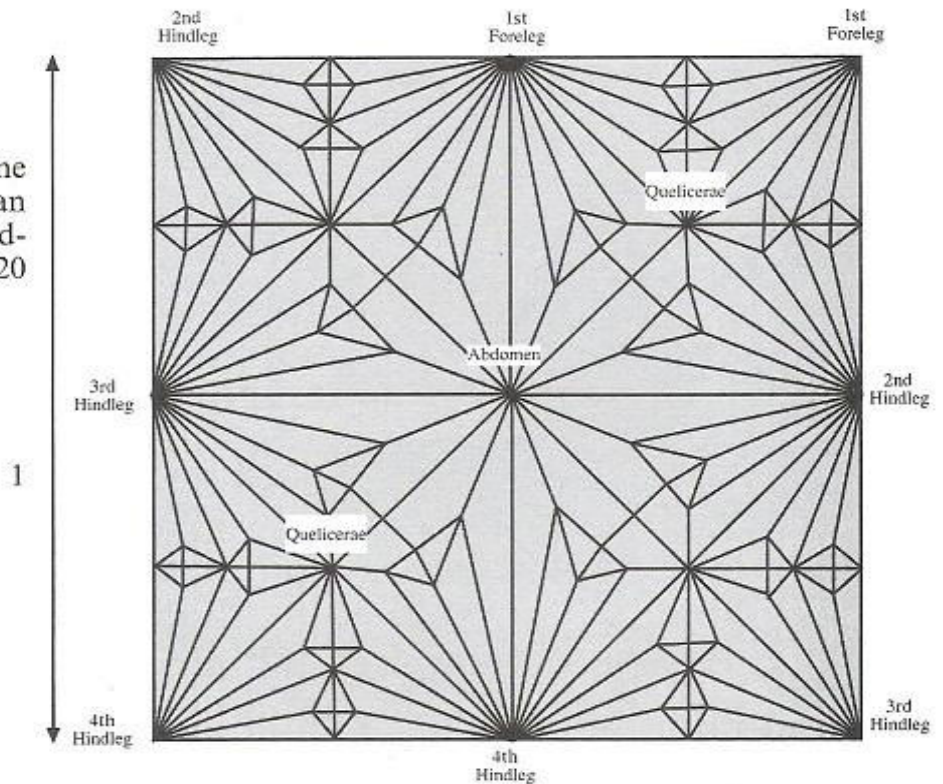
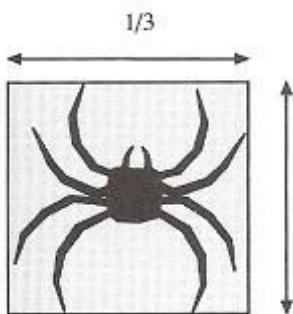

Steps 1 until 32 of the Black Widow

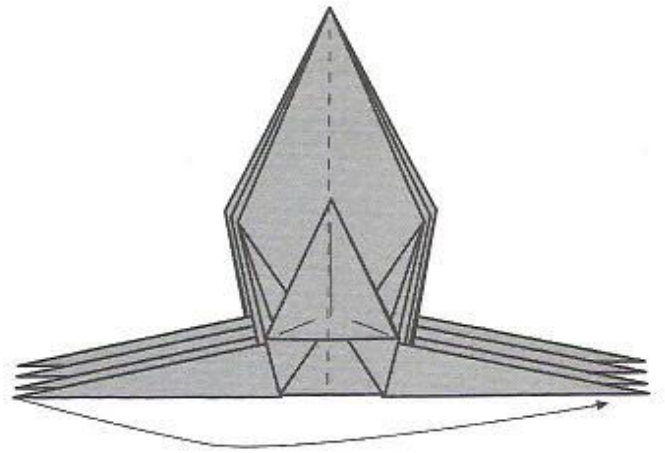

33

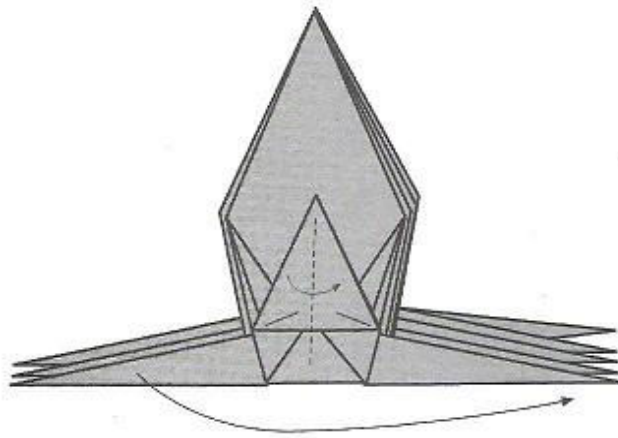

34

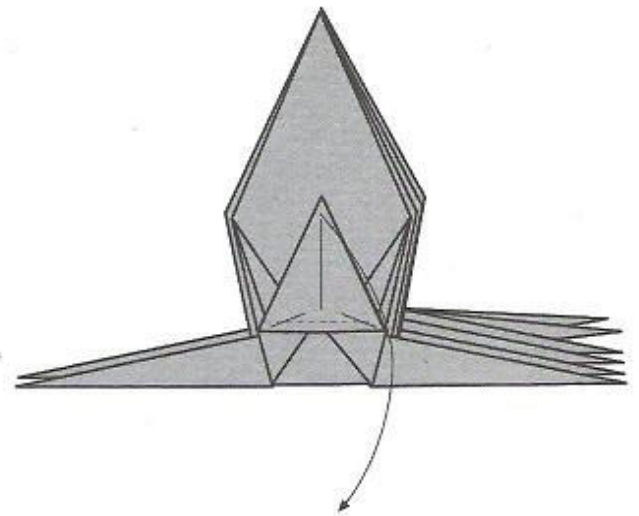

35

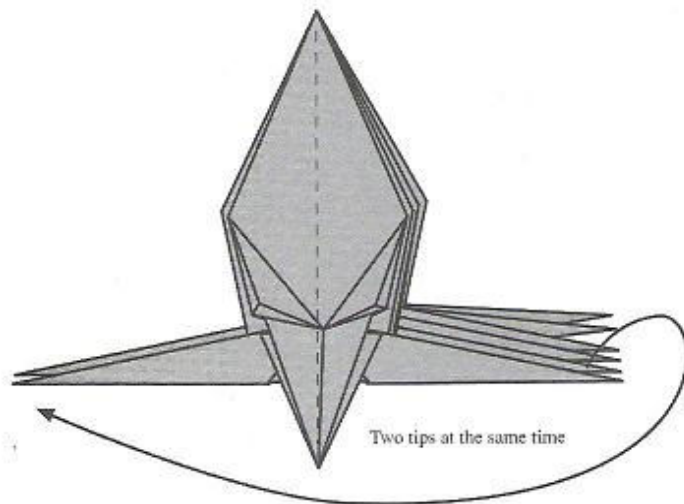

36

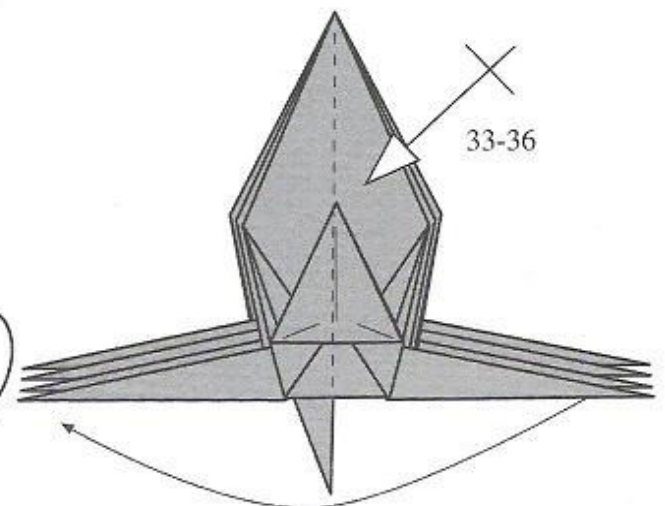

37

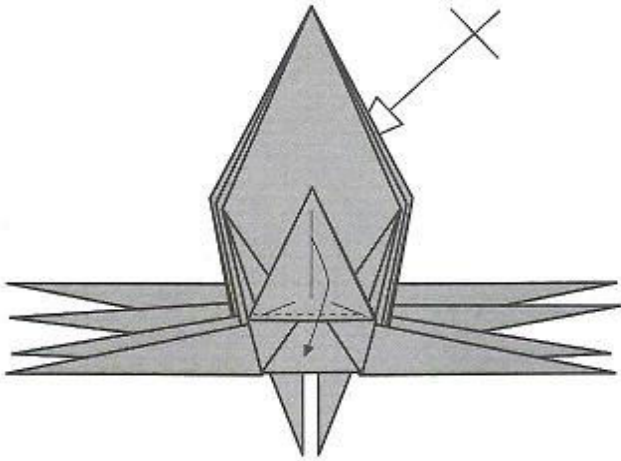

38

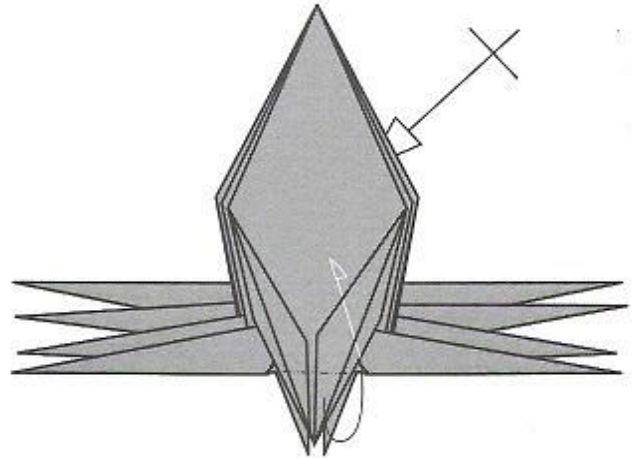

39

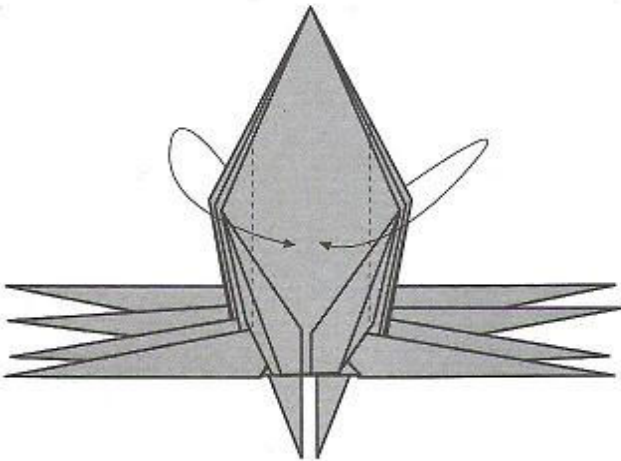

40

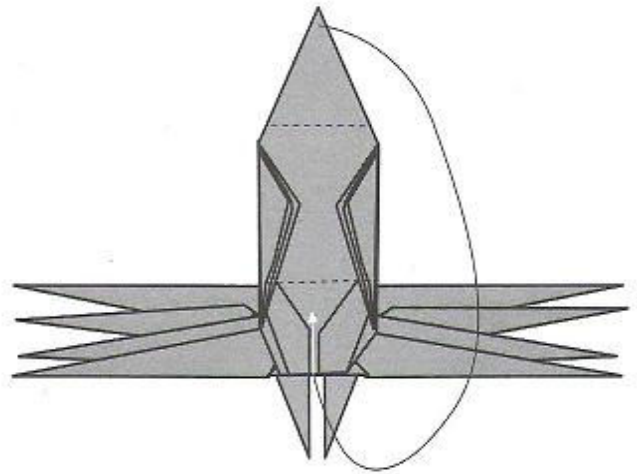

41

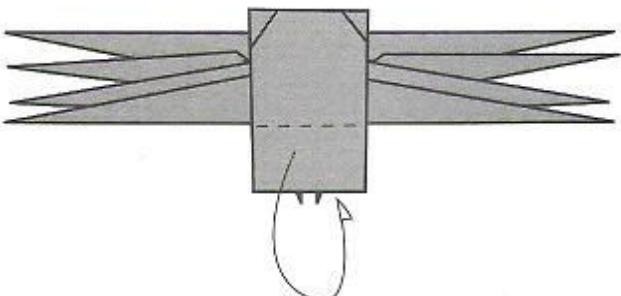

42

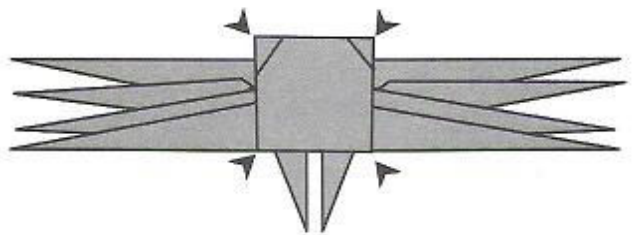

43

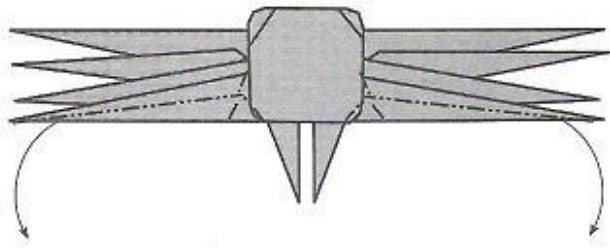

44

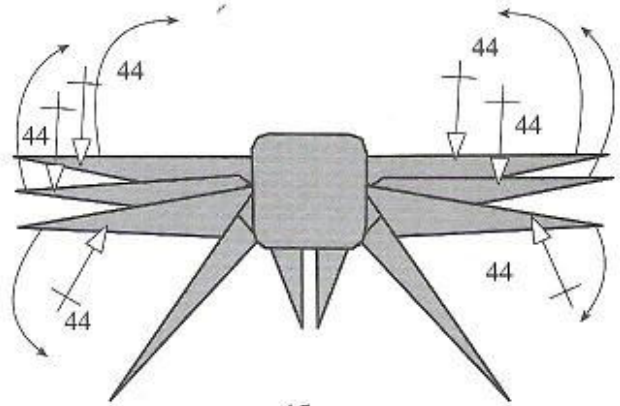

45

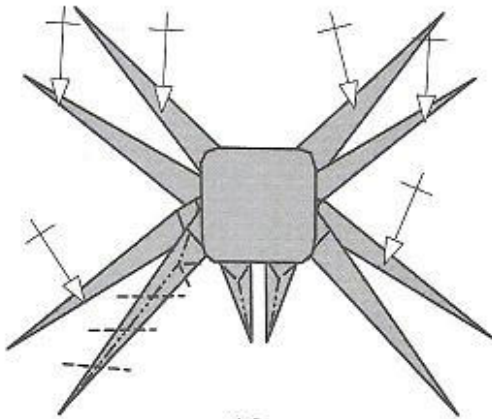

46

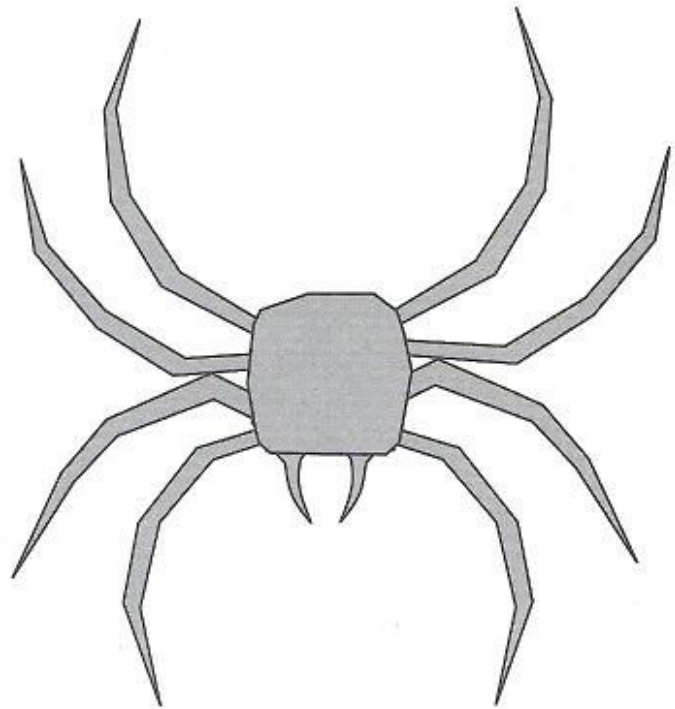

47

Stingray (Eagle ray)

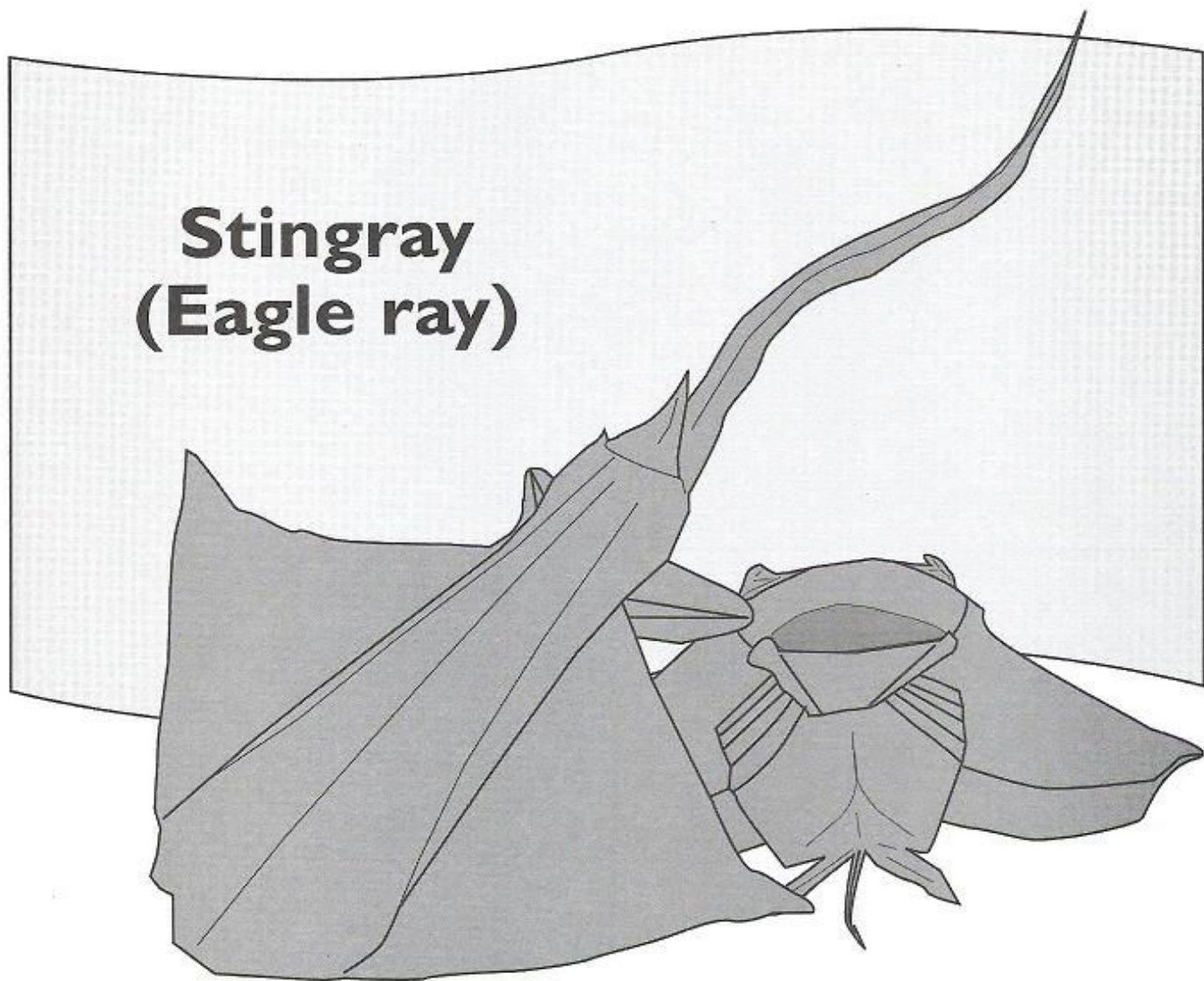

The paper can be of varied color. It is recommended 7.9x7.9 inches (20x20 cm) or bigger.

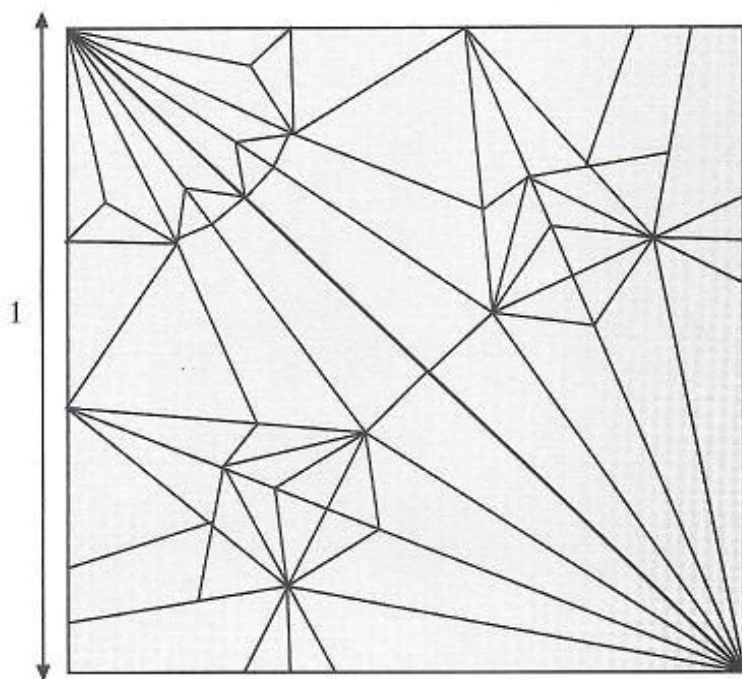
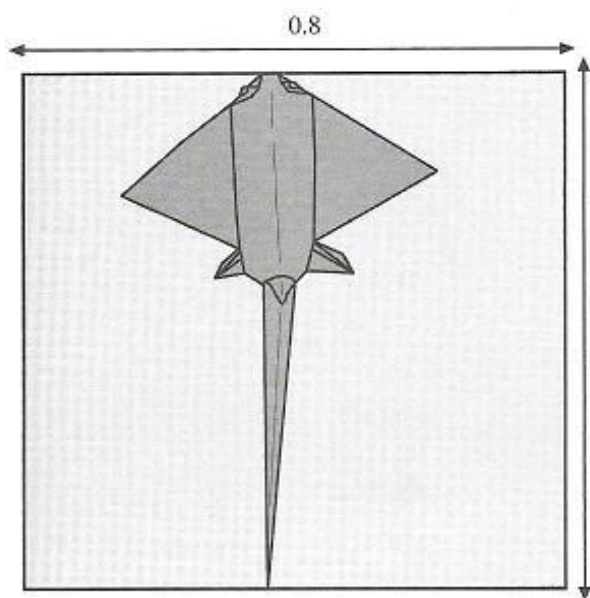

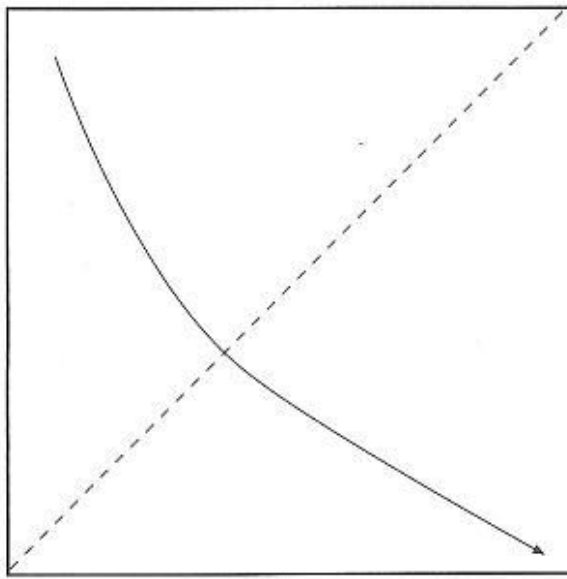

1



45°

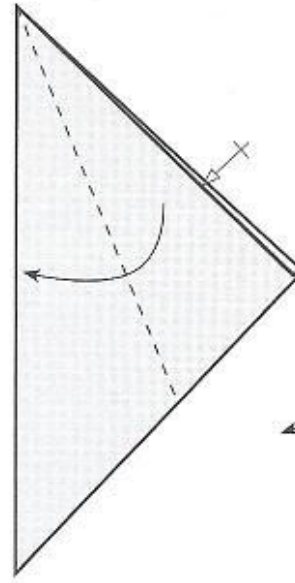

2

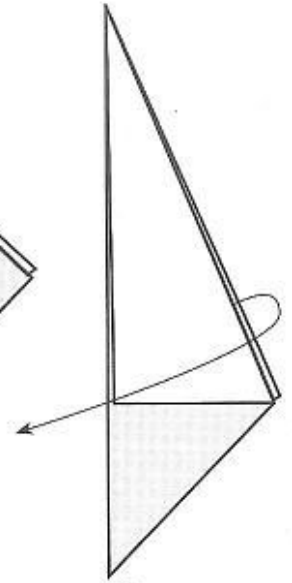

3

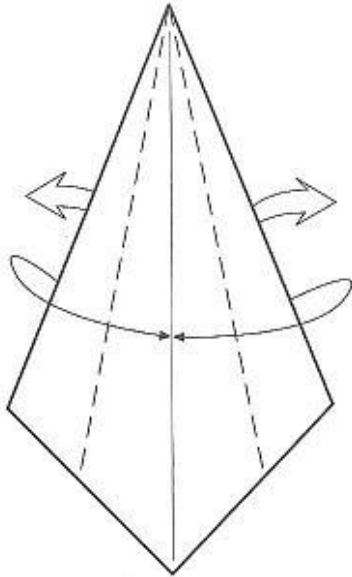

4

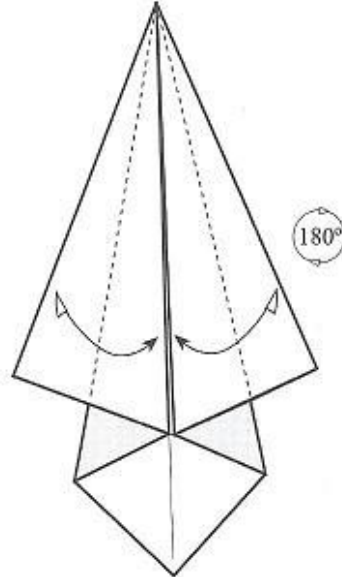

180°

5

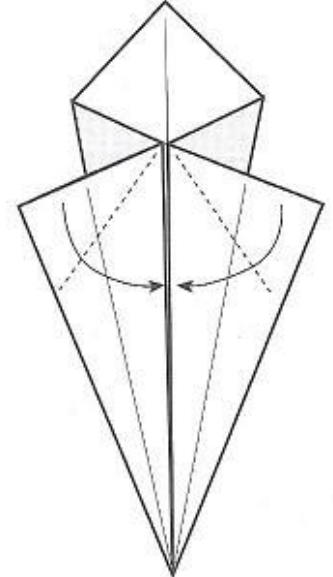

6

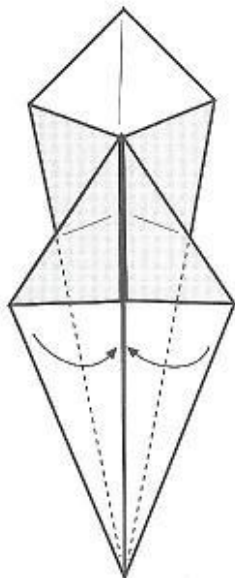

7



8

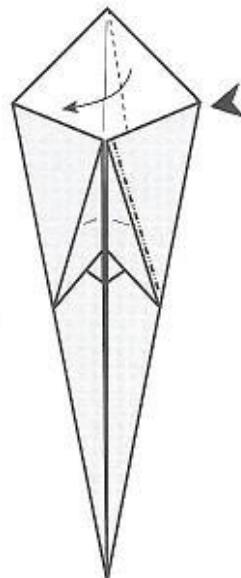

9

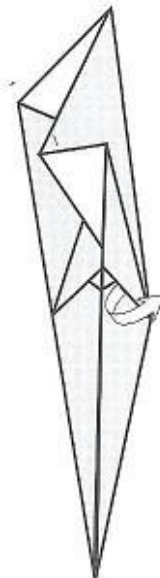

10

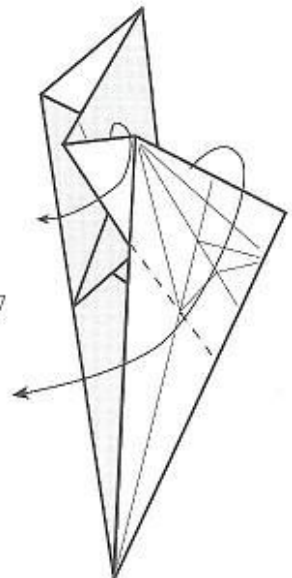

11

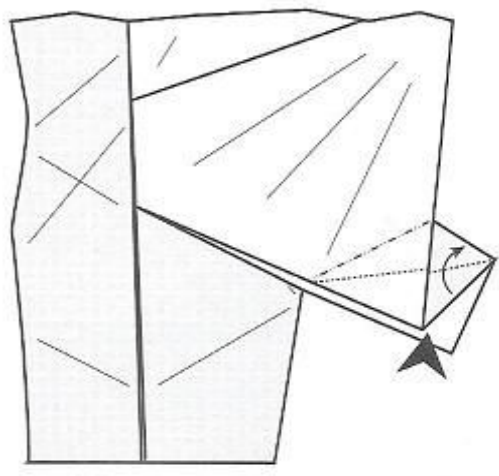
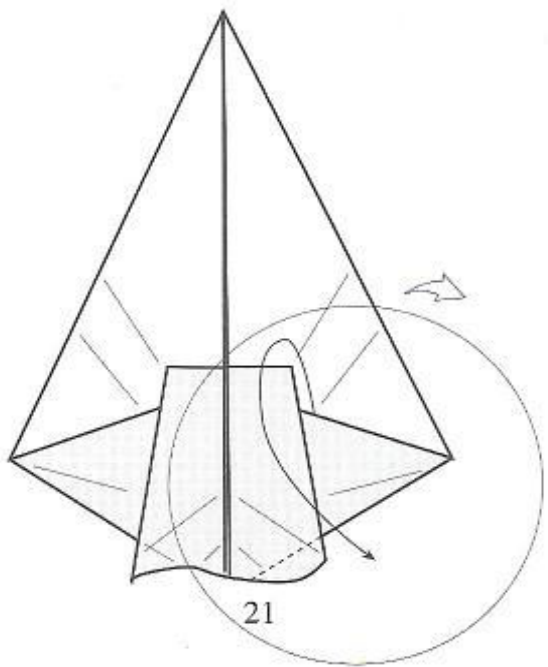
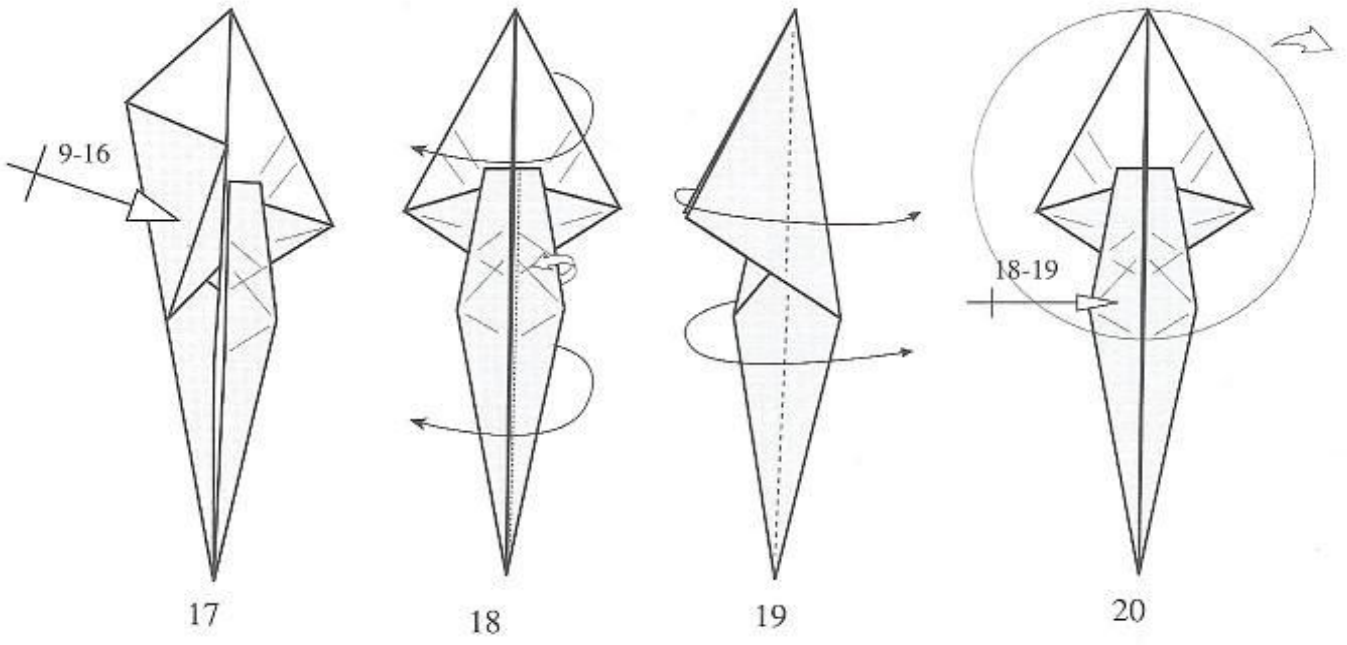
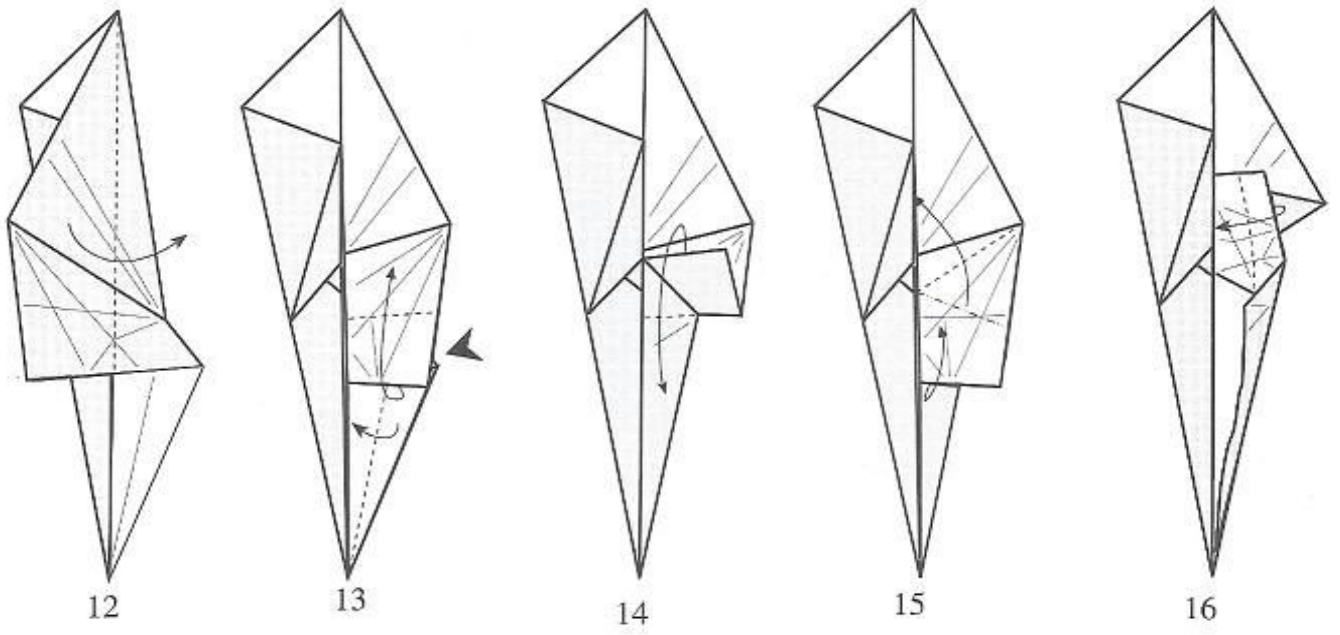

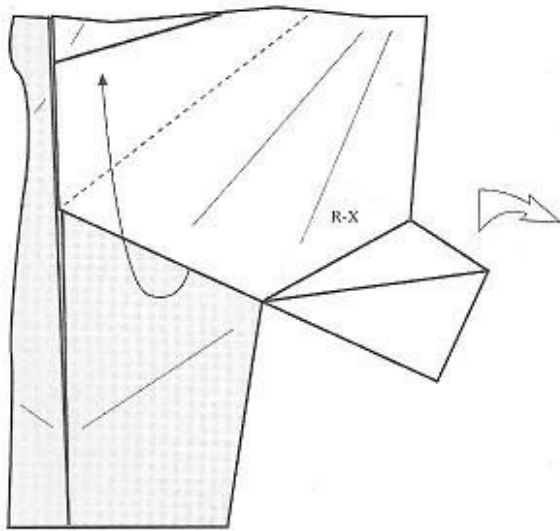

23

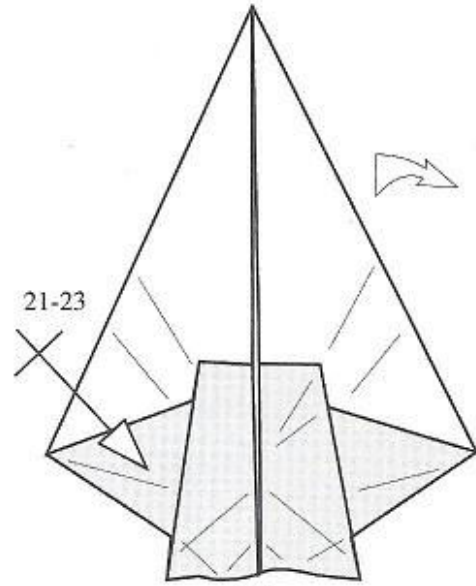

24

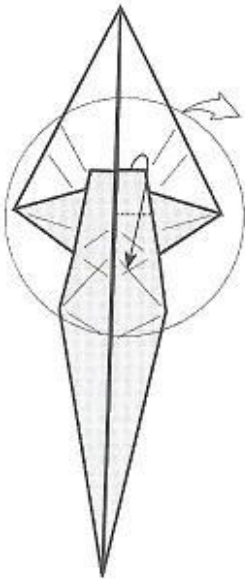

25

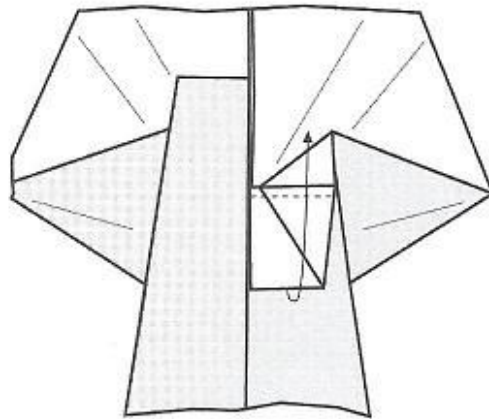

26

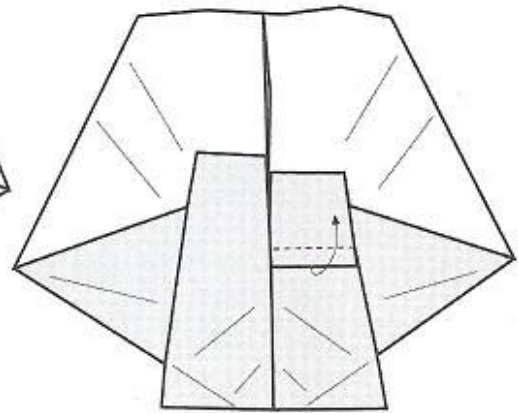

27

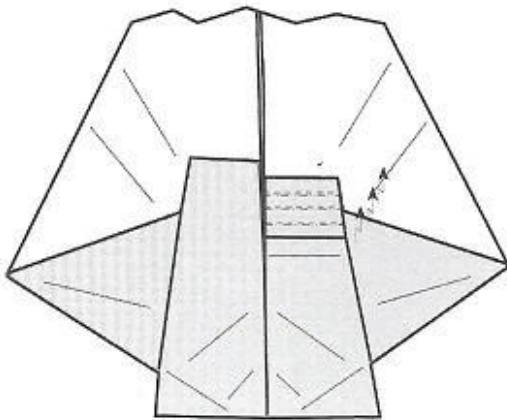

28

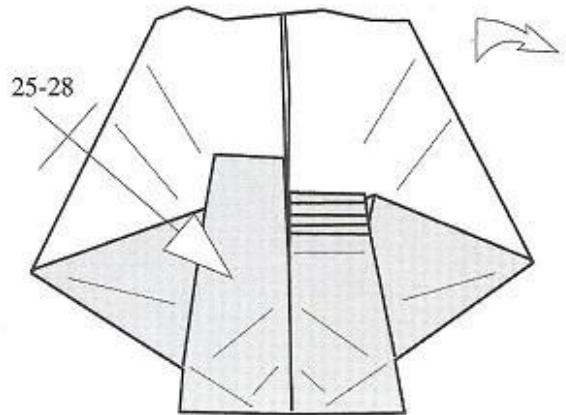

29

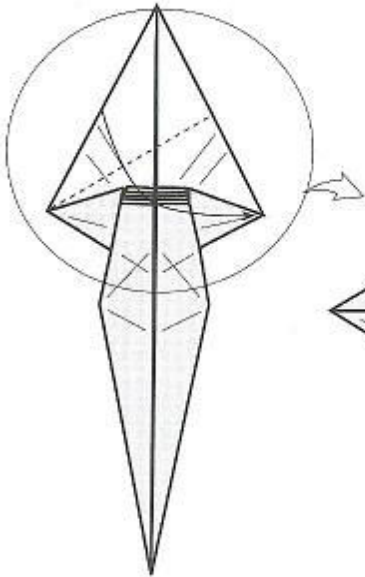

30

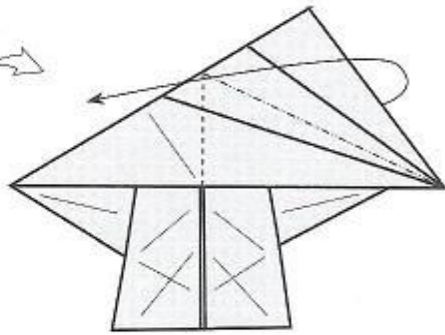

31

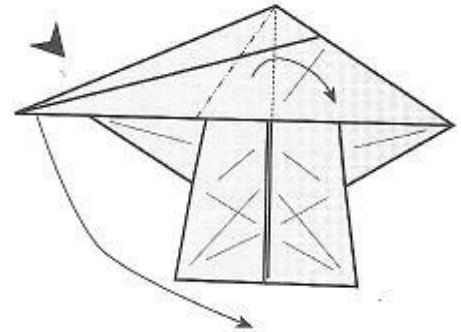

32

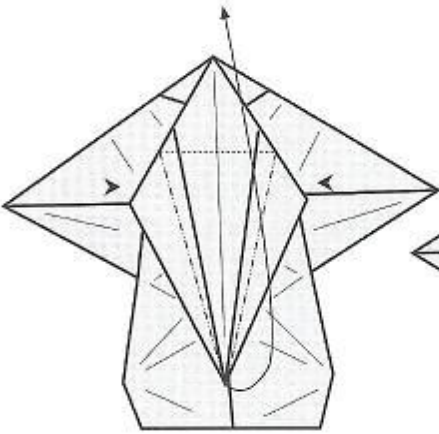

33

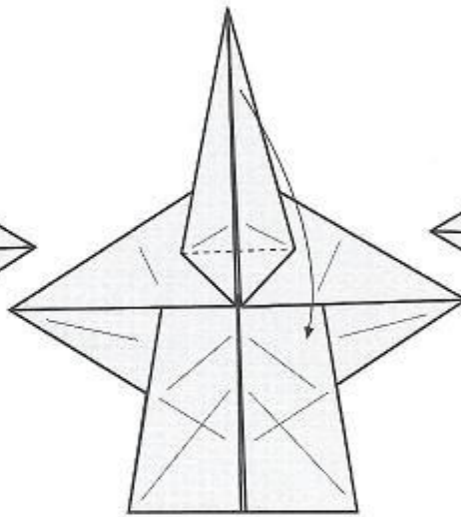

34

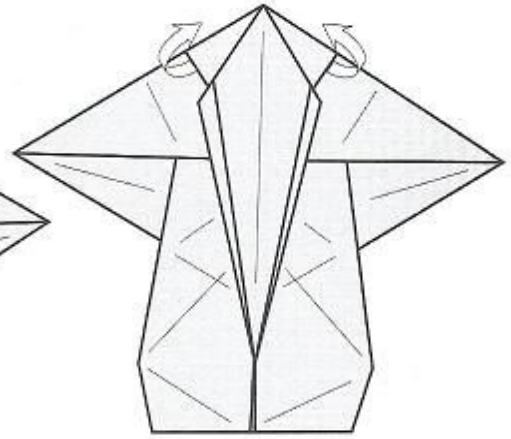

35

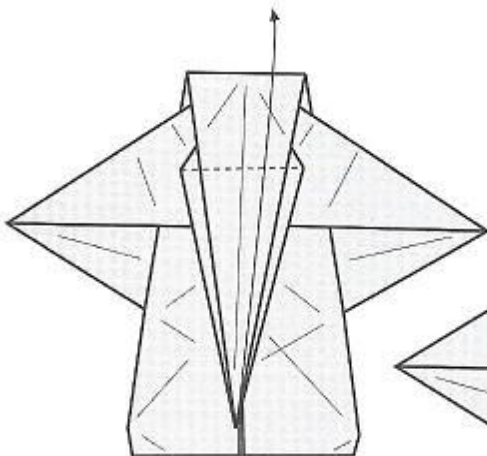

36

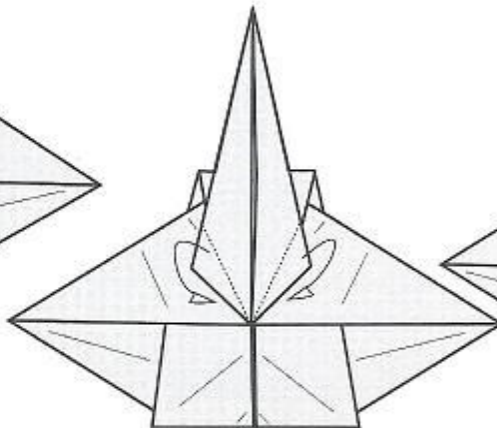

37

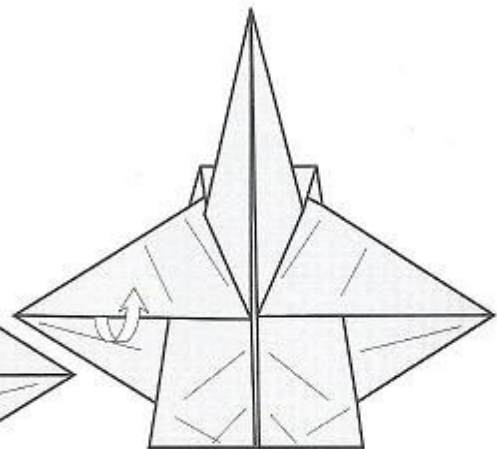

38

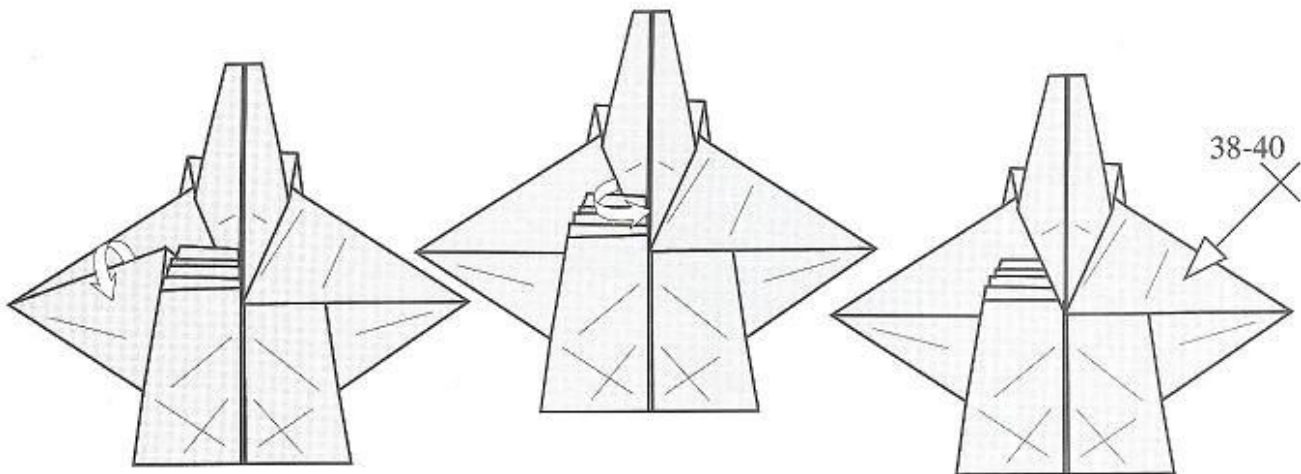

39

40

41

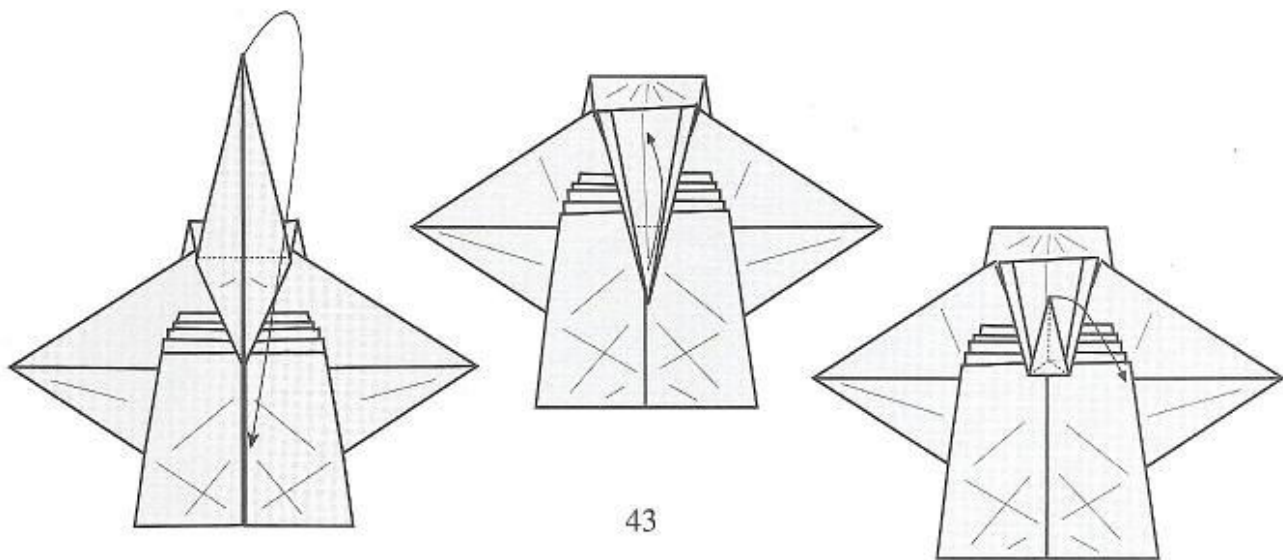

42

43

44

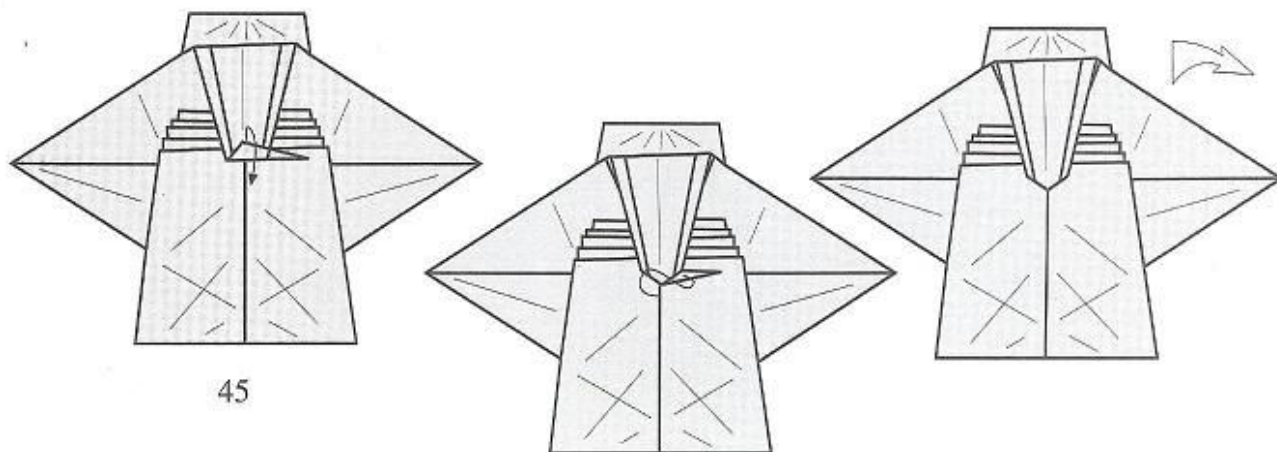

45

46

47

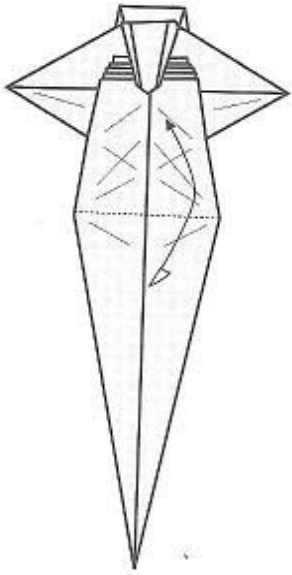

48

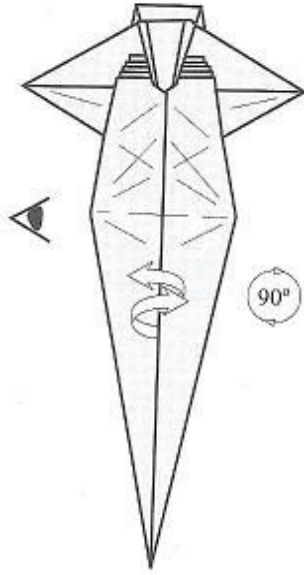

49

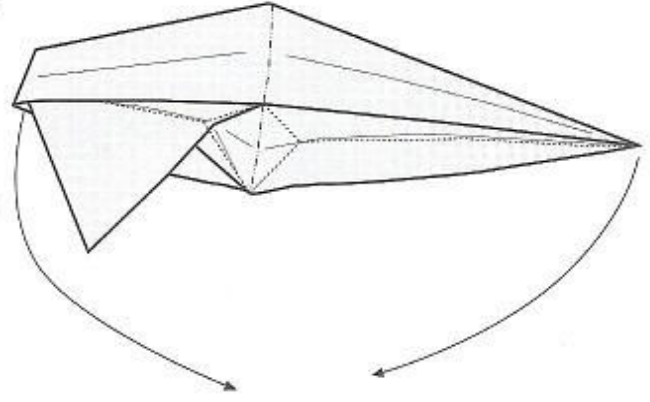

50

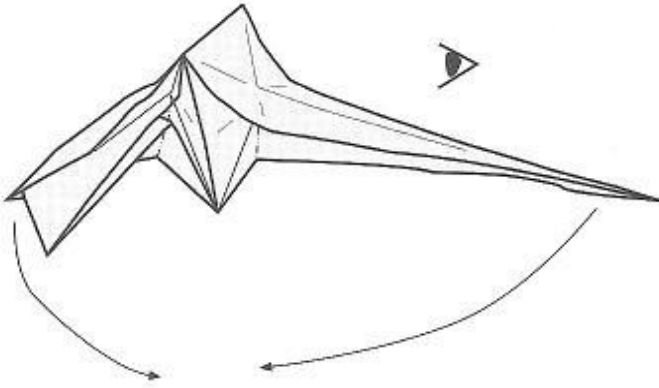

51

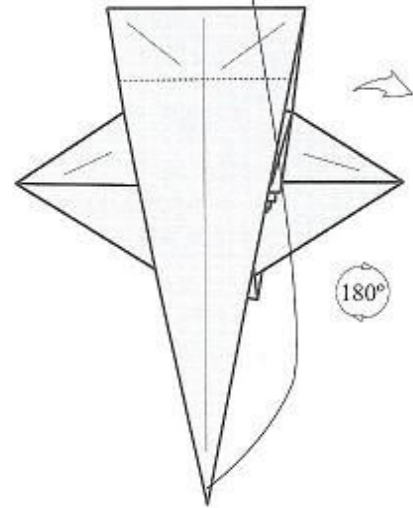

52

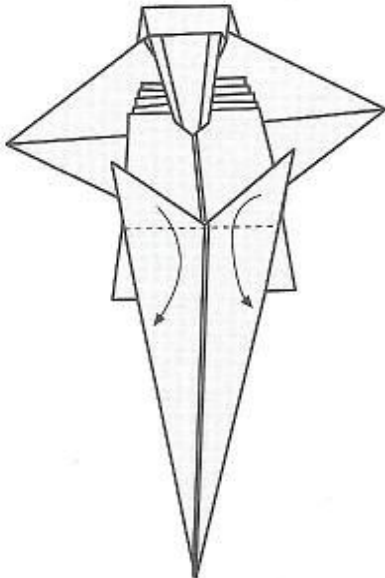

53

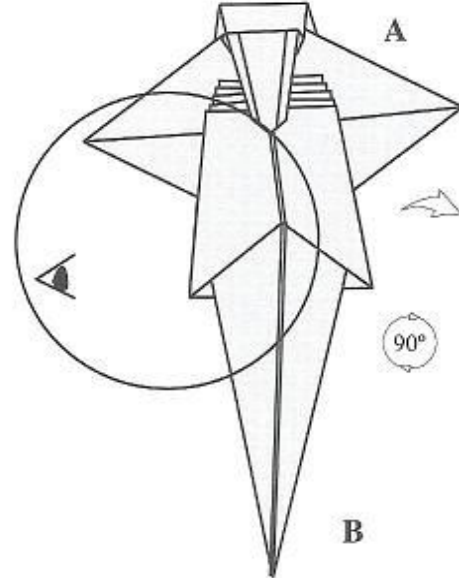

54

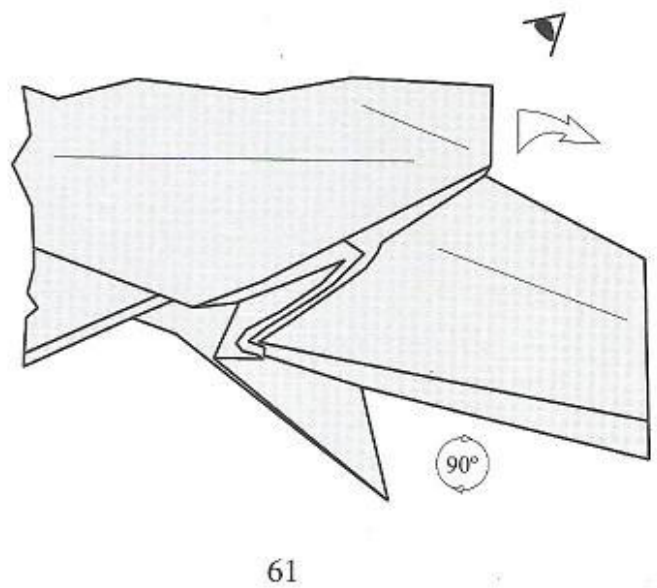
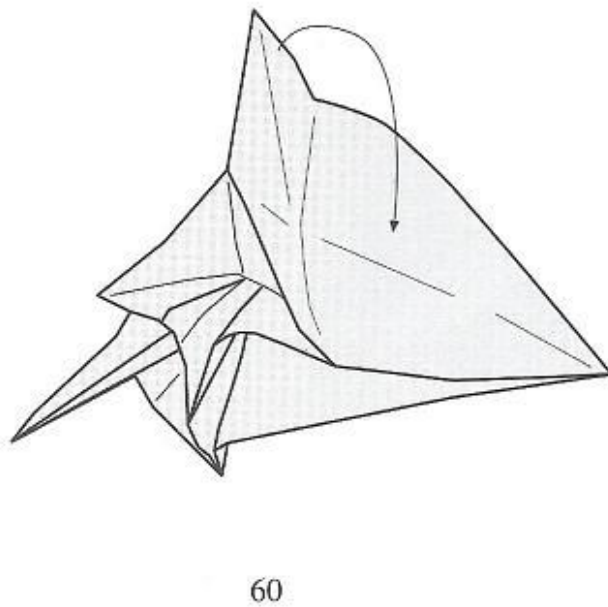
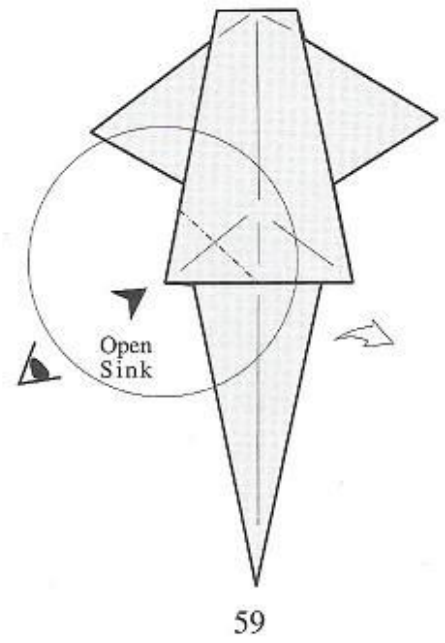
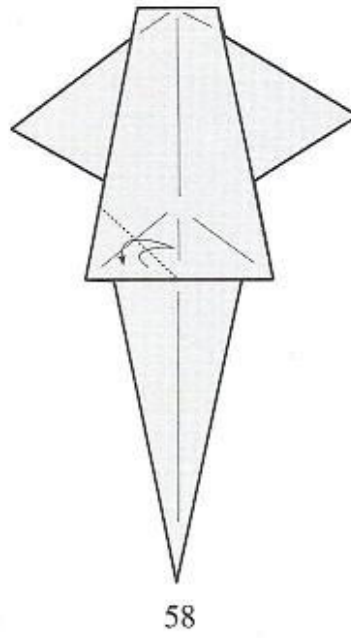
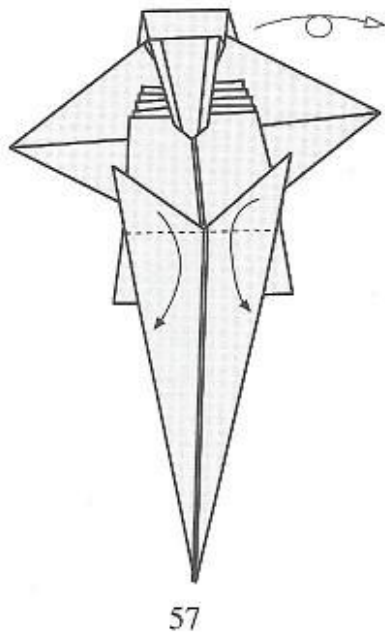
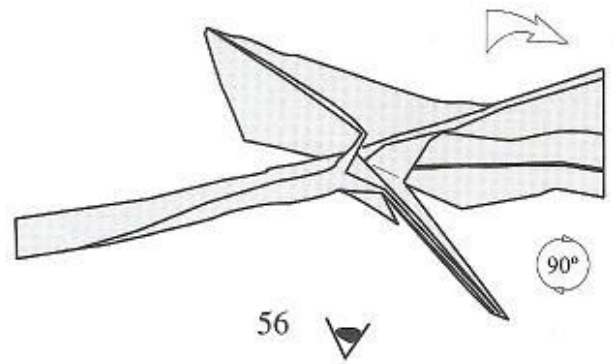
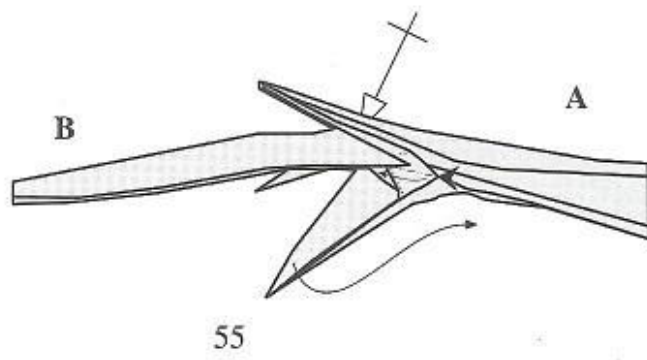

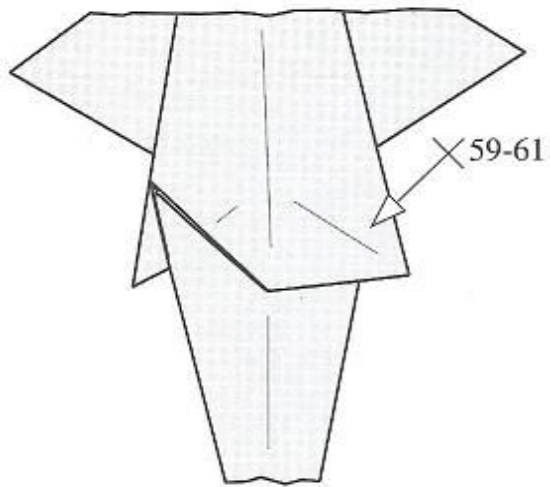

62

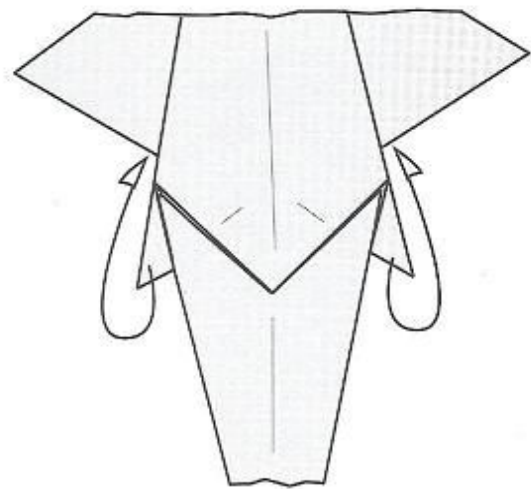

63

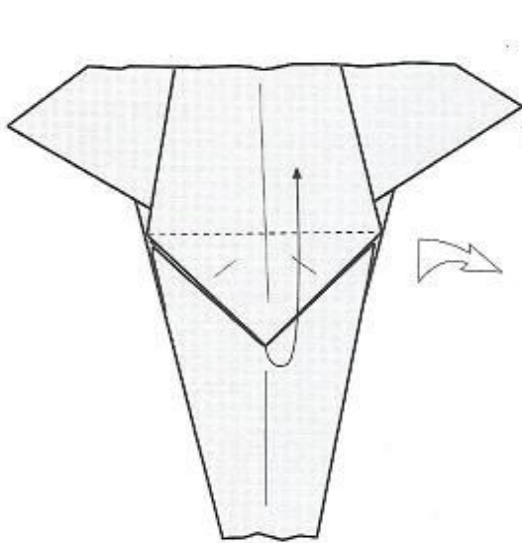

64

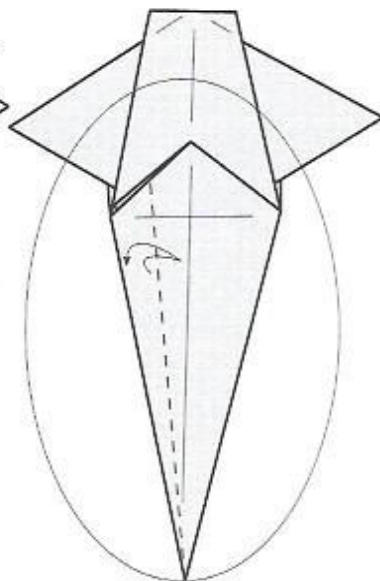

65

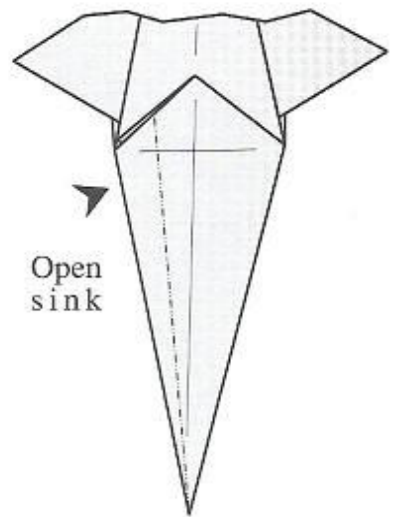

66

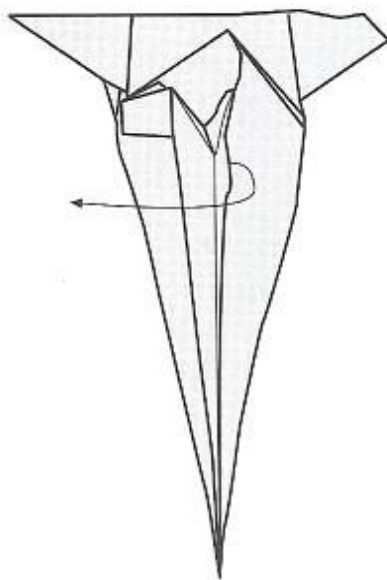

67

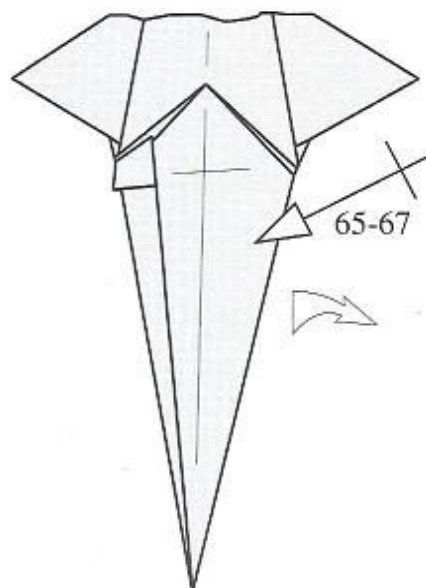

68

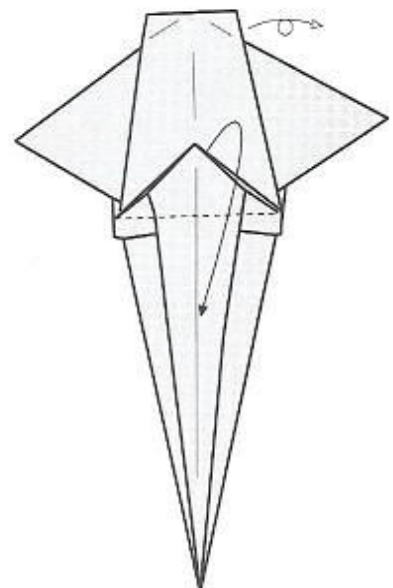

69

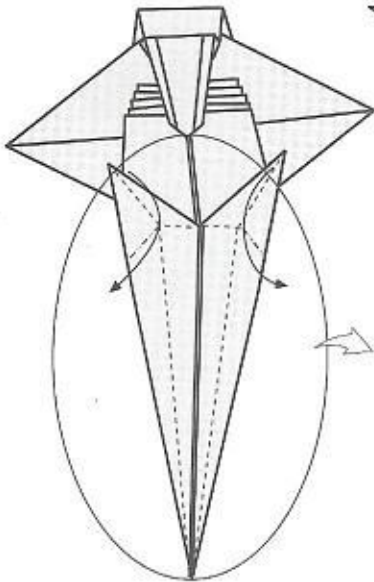

70

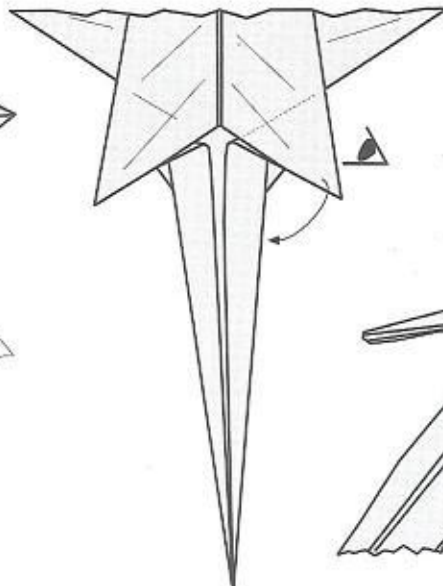

71

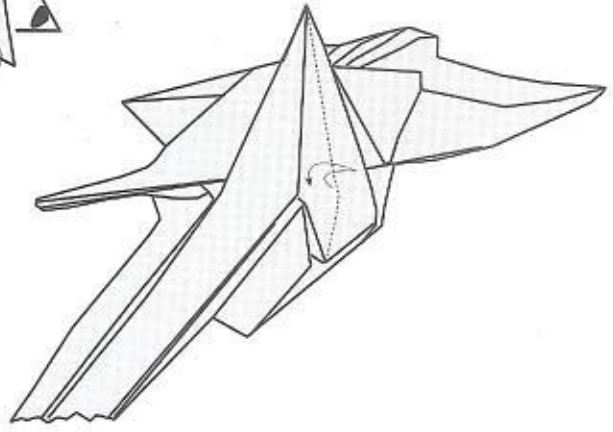

72

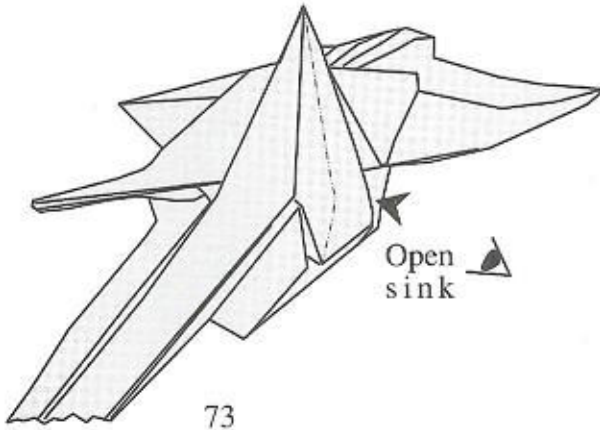

73

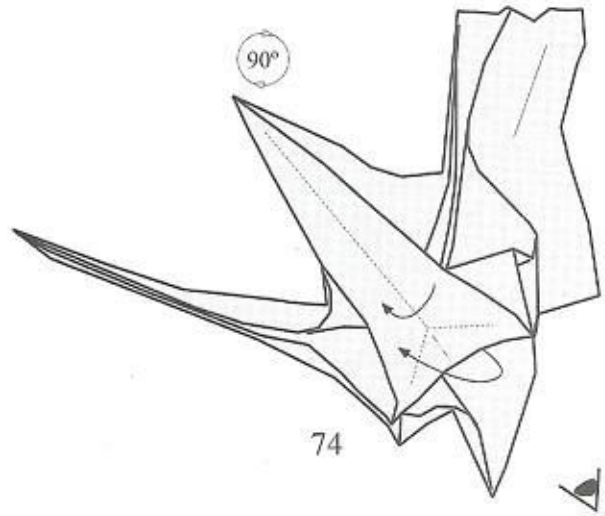

74

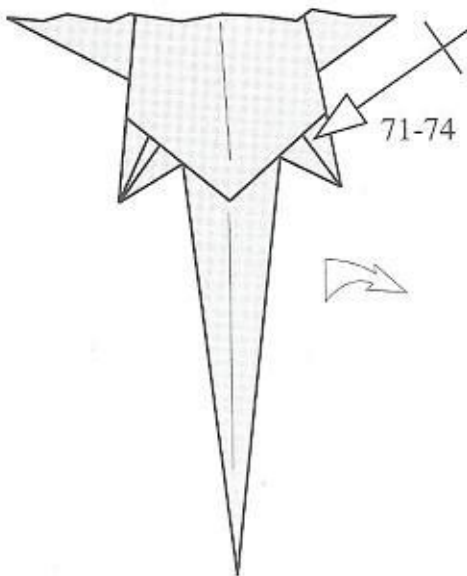

75

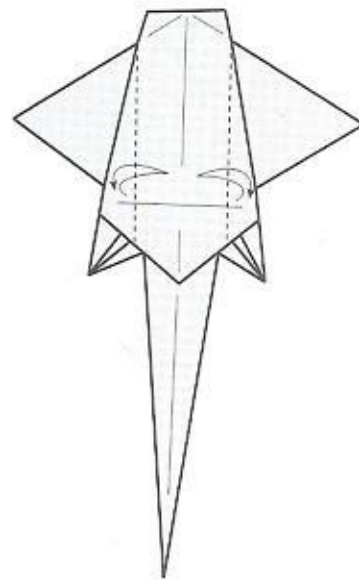

76

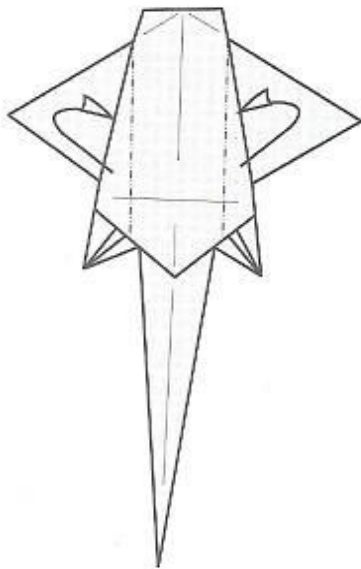

77

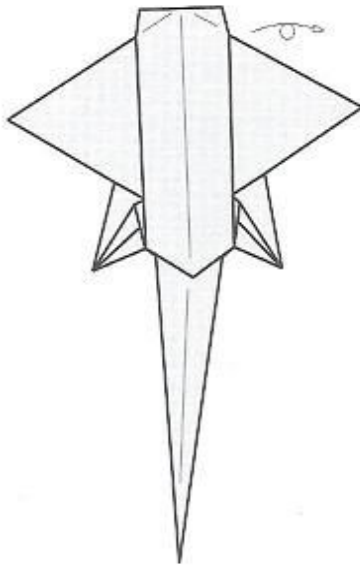

78

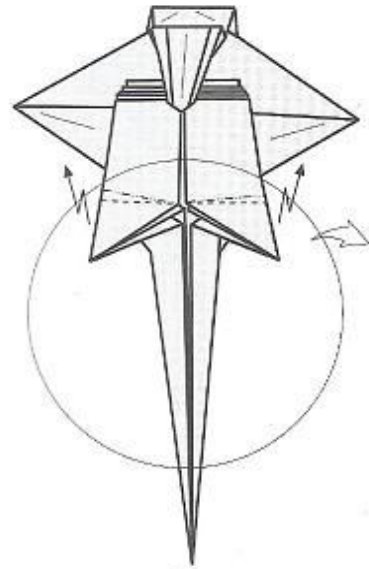

79

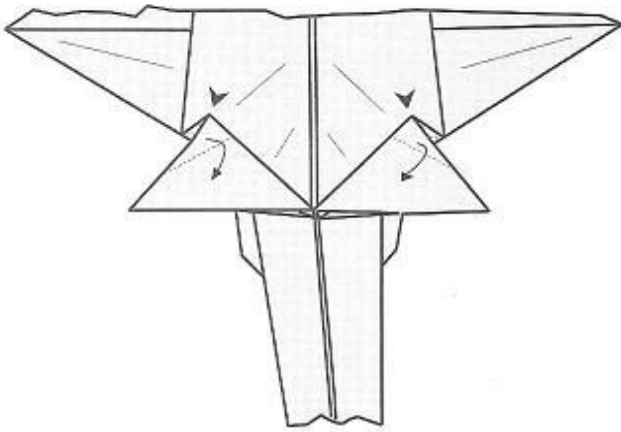

80

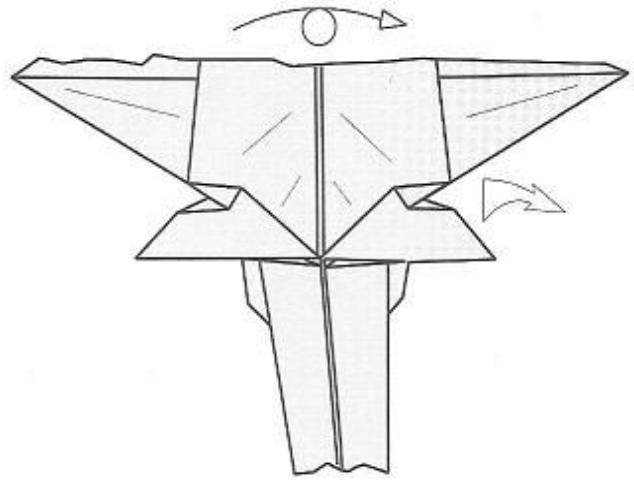

81

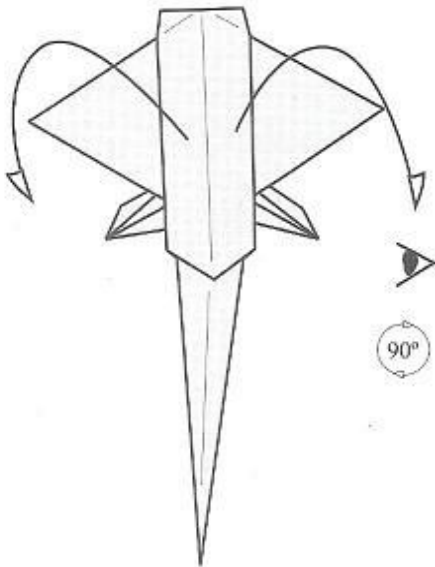

82

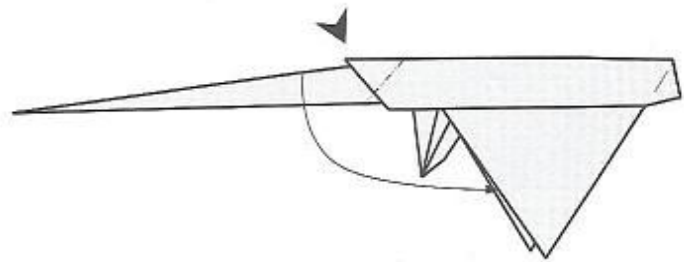

83

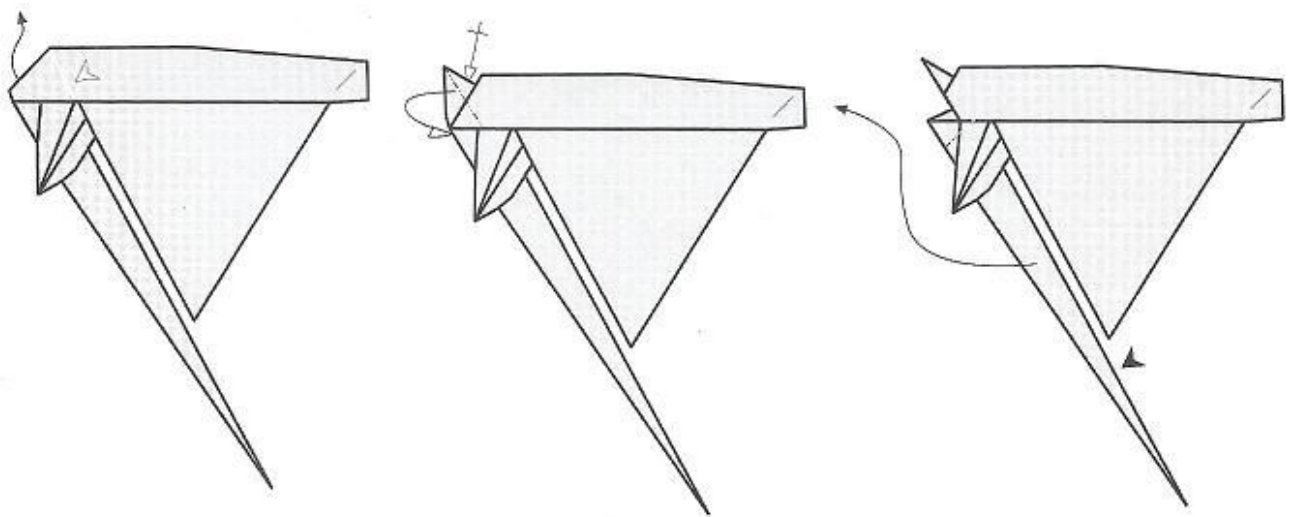

84

85

86

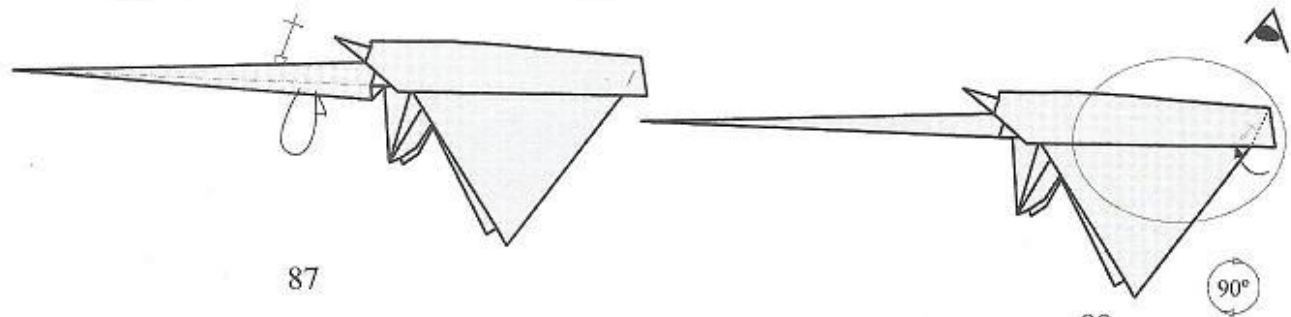

87

88

90°

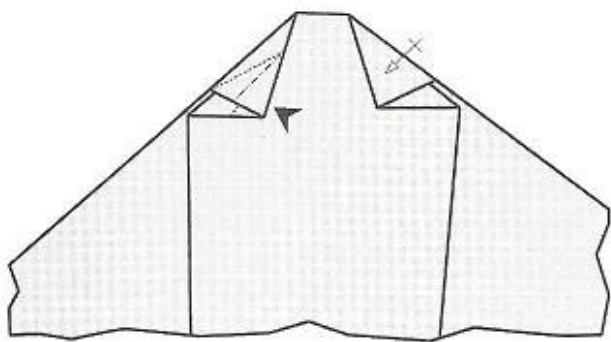

89

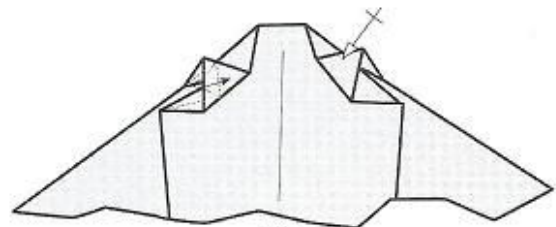

90

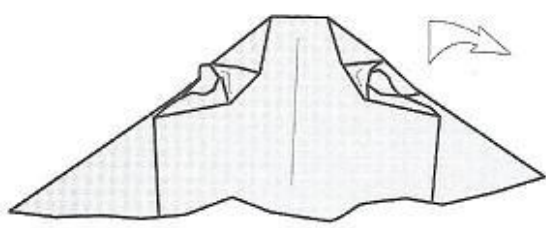

91

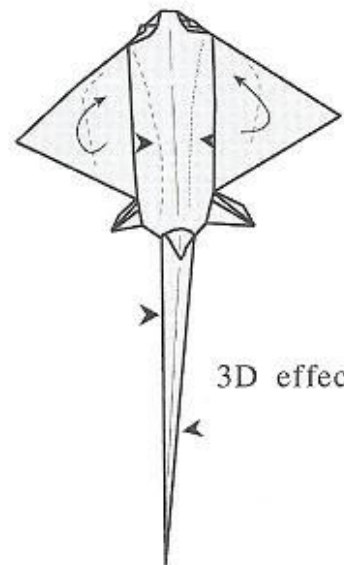

92

3D effects

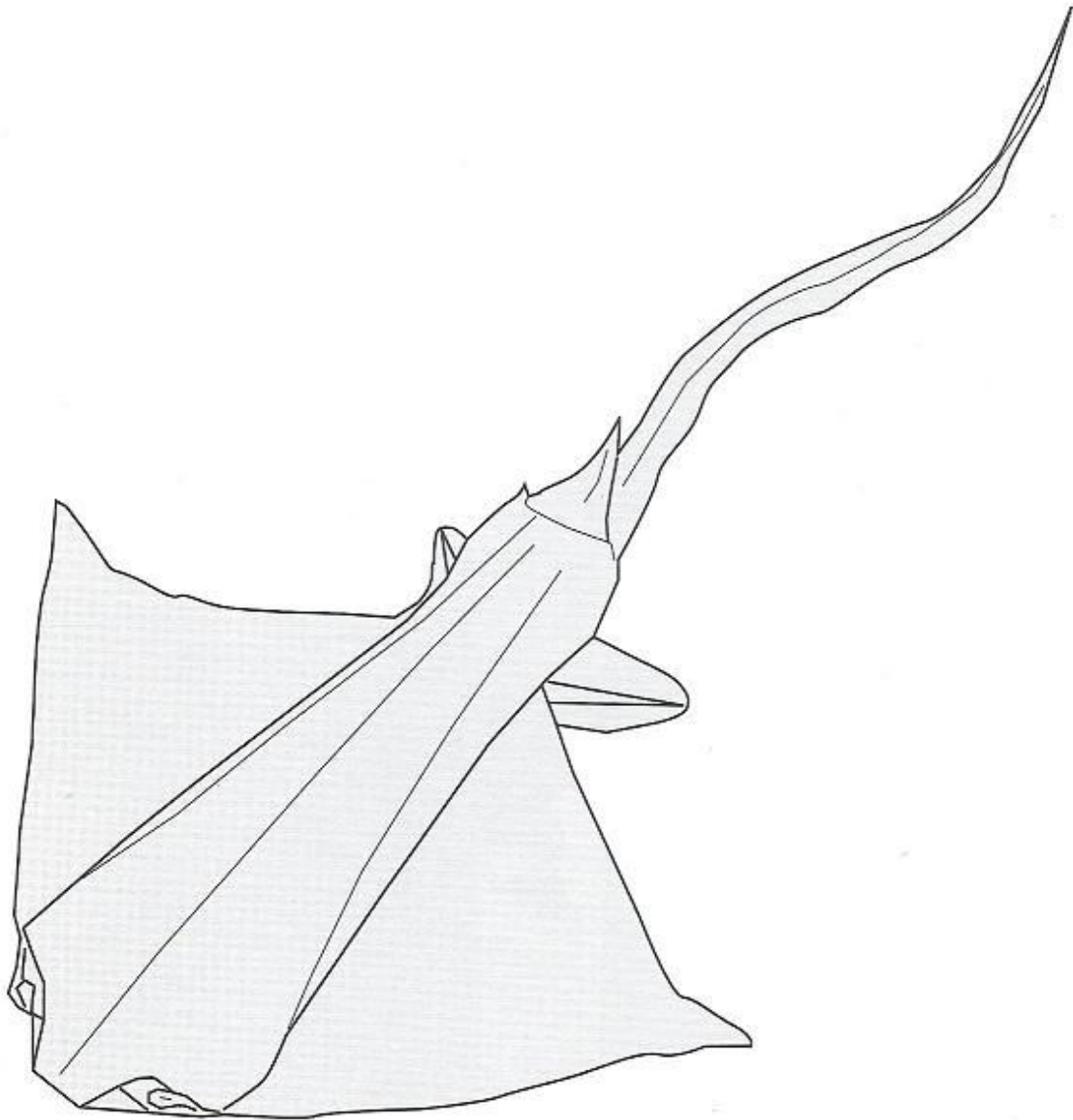

93

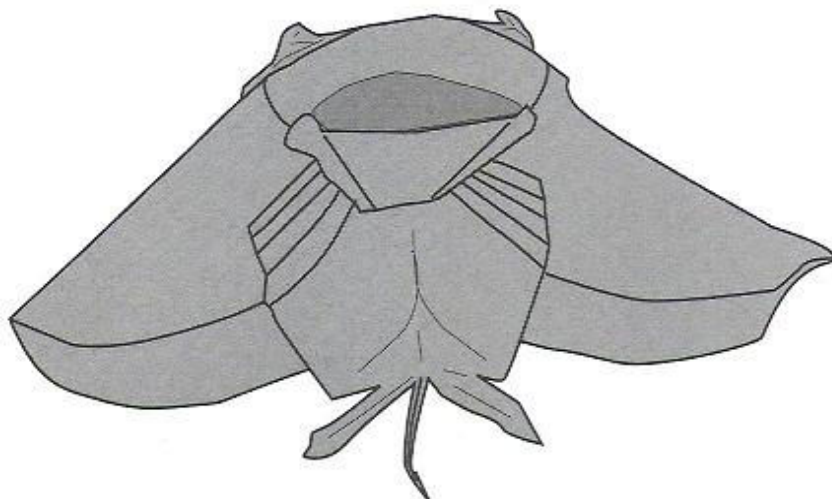

75

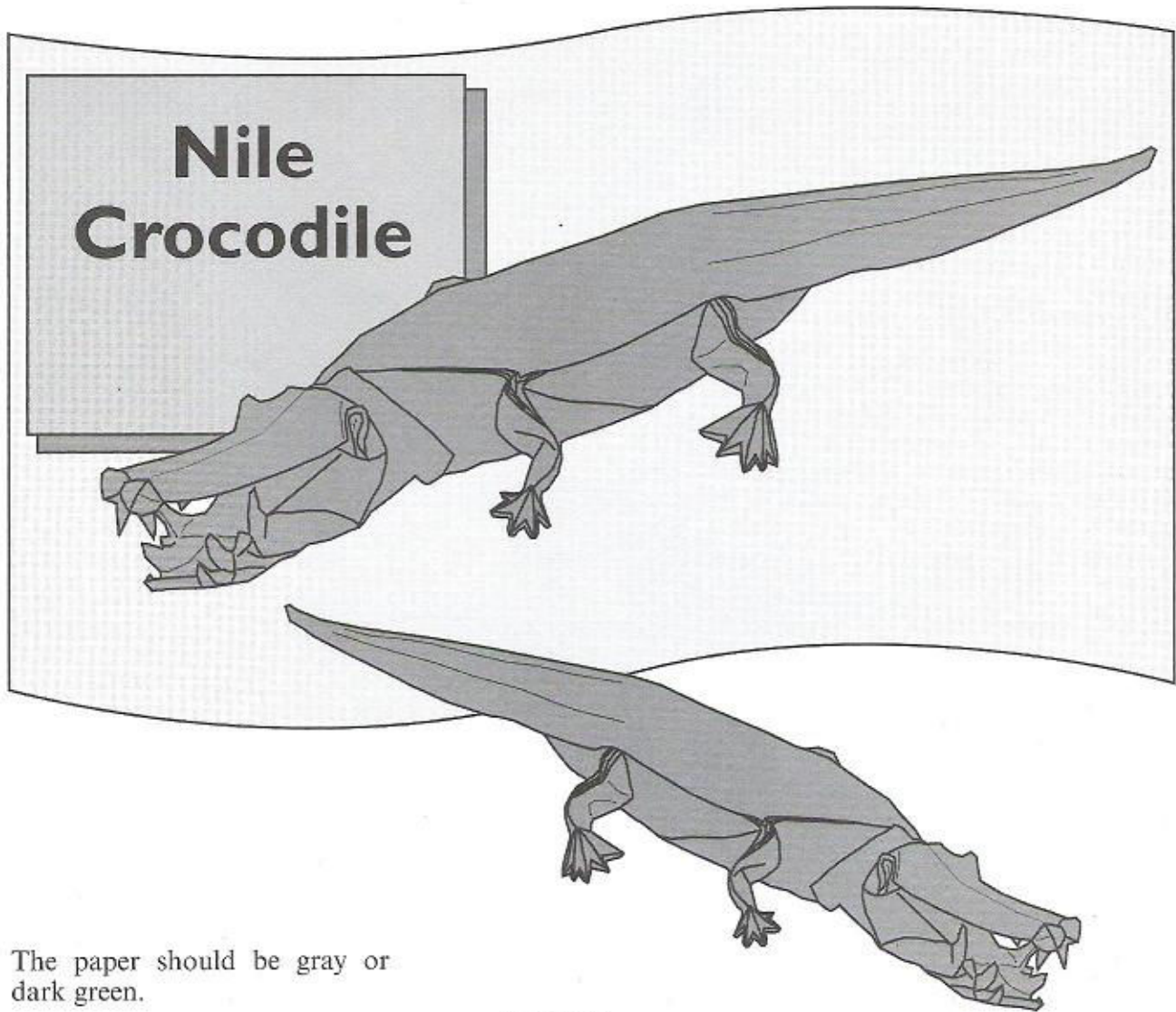

The paper should be gray or dark green.

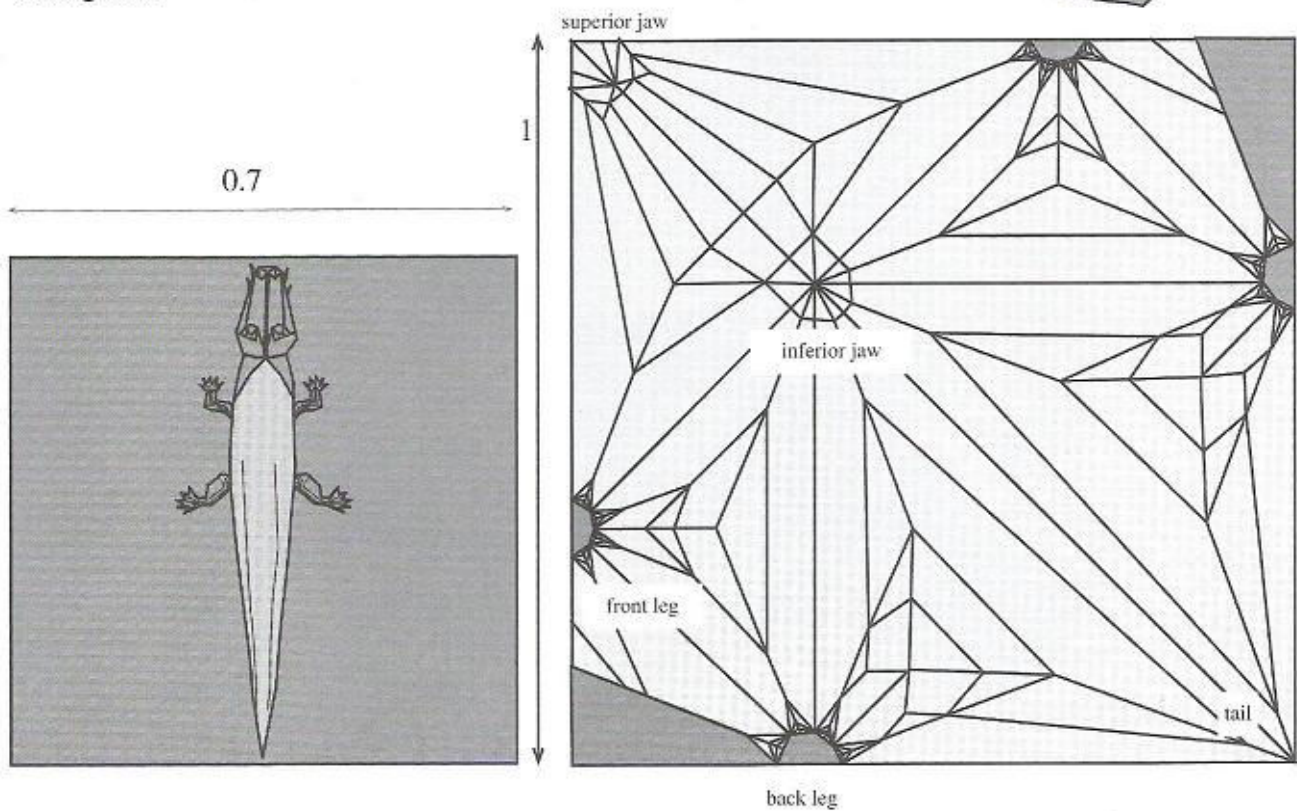

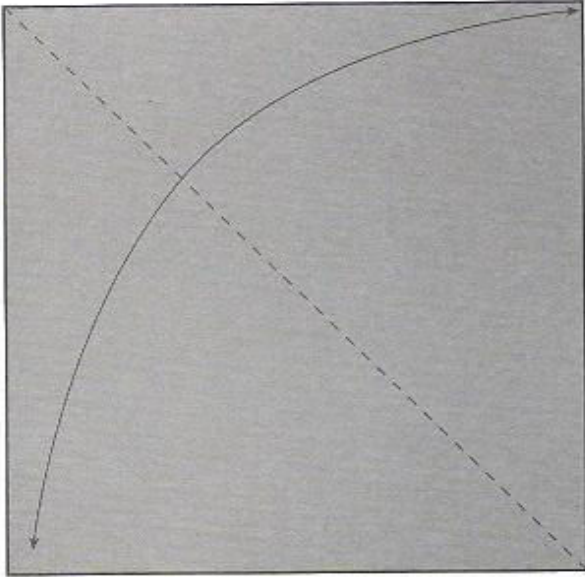

1 ●

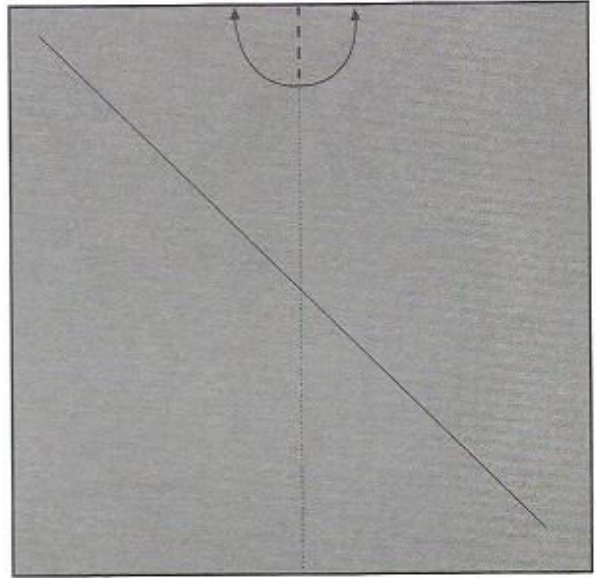

2

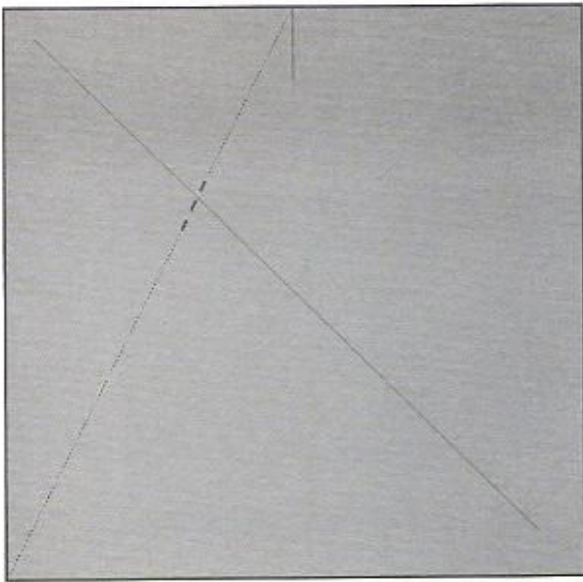

3

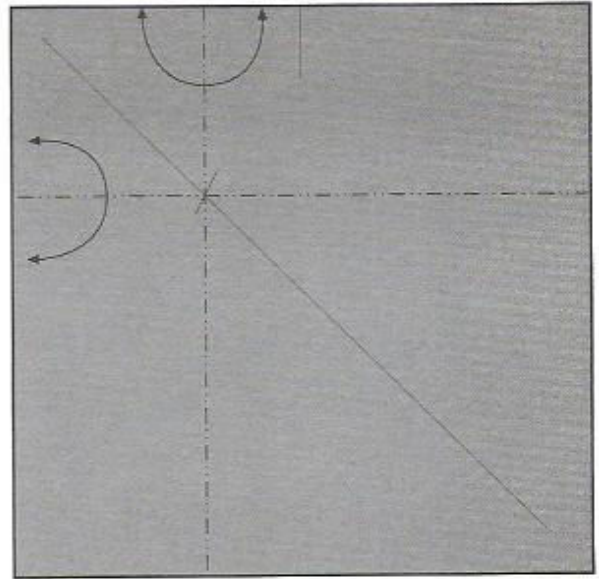

4

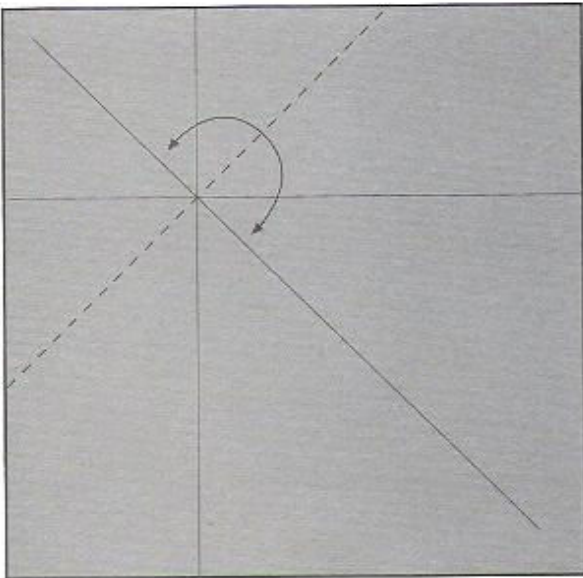

5

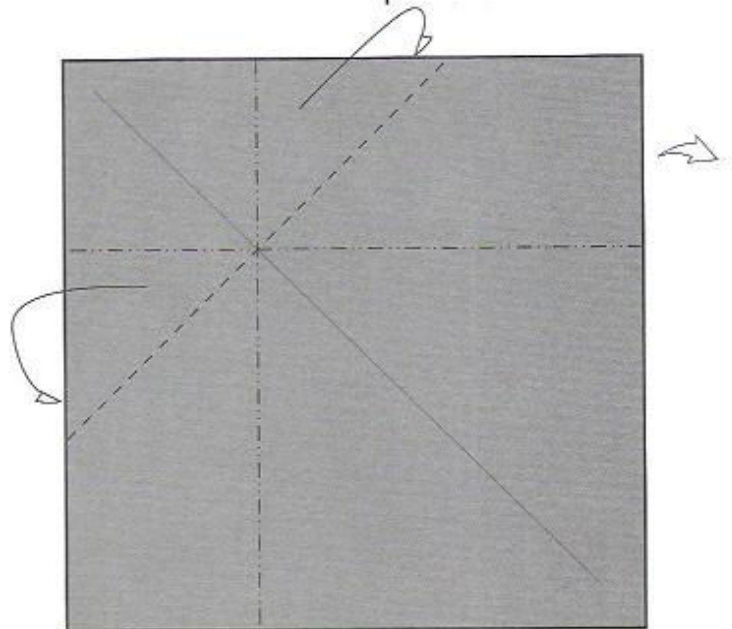

6

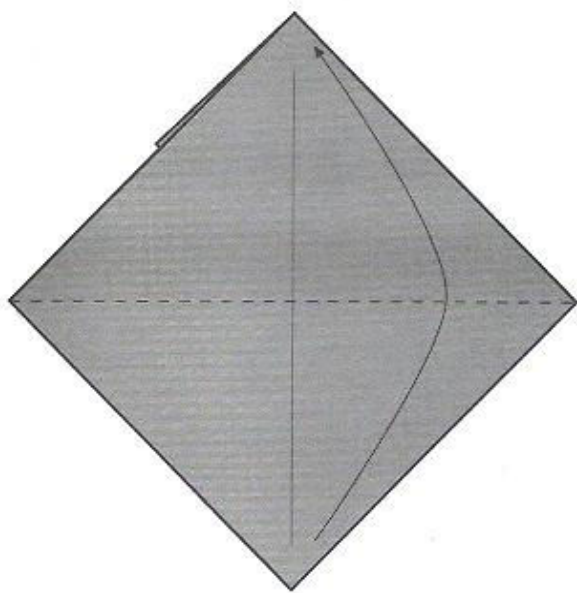

7

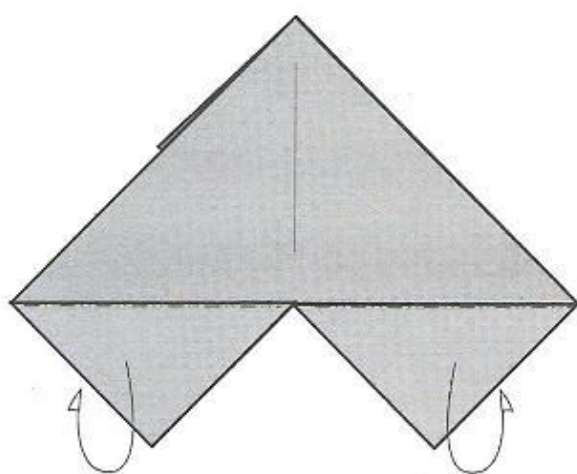

8

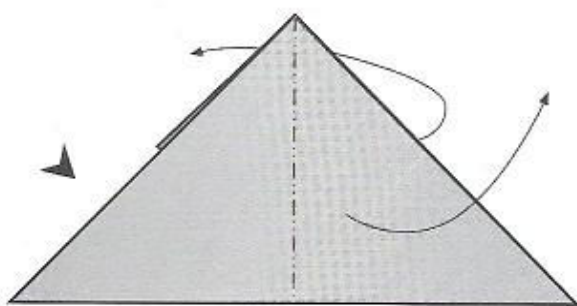

9

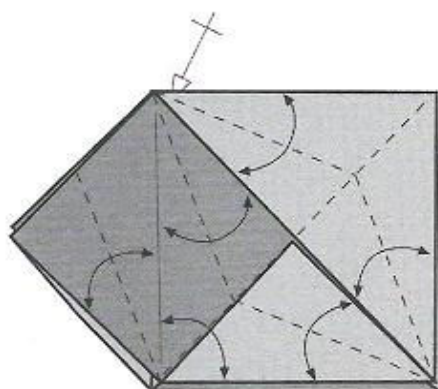

10

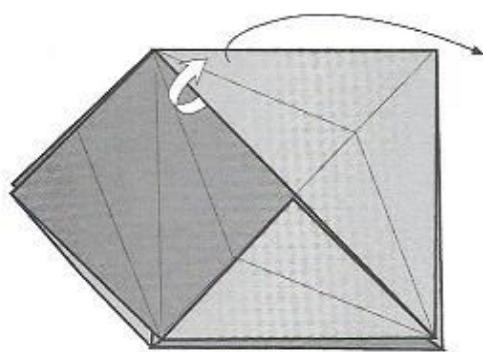

11

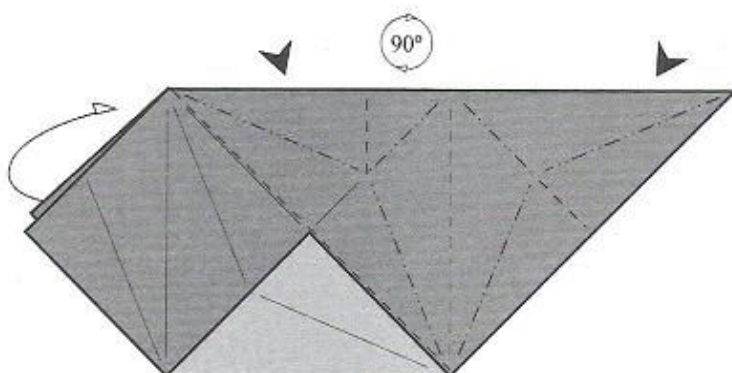

12

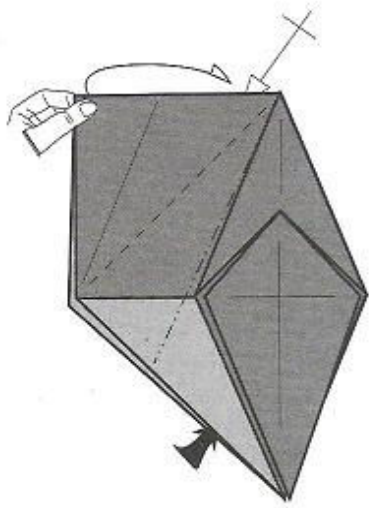

13

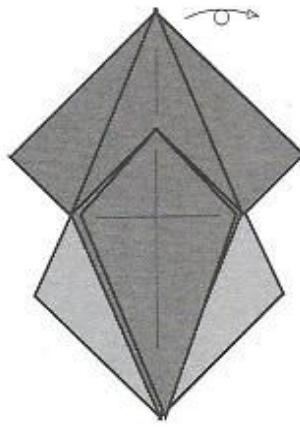

14

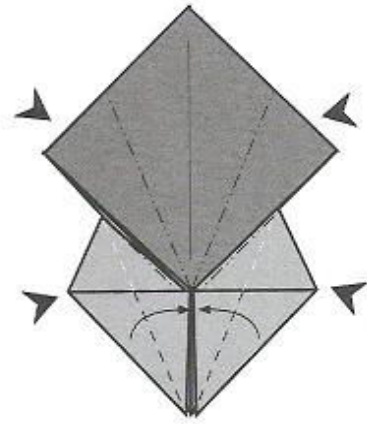

15

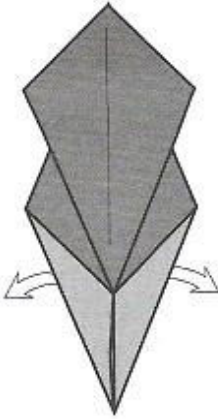

16

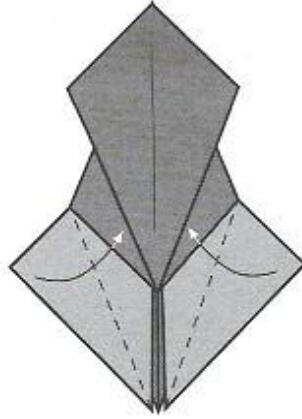

17

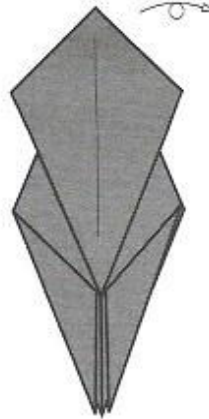

18



19

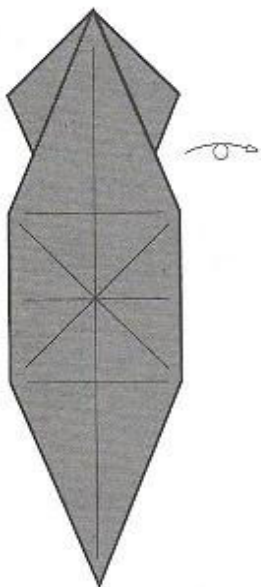

20

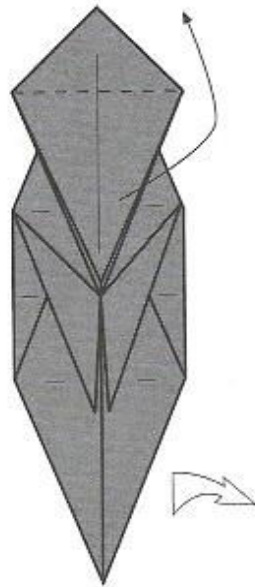

21



22

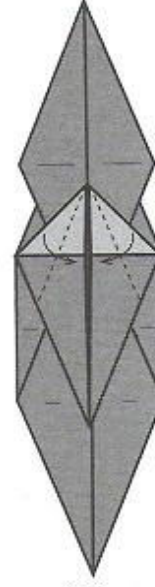

23



24

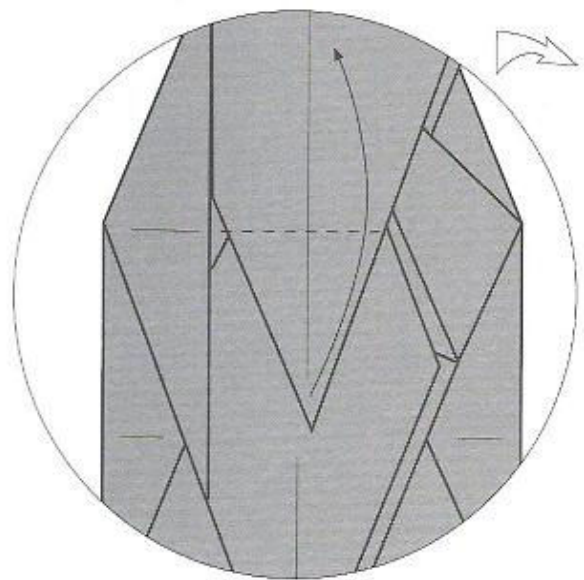
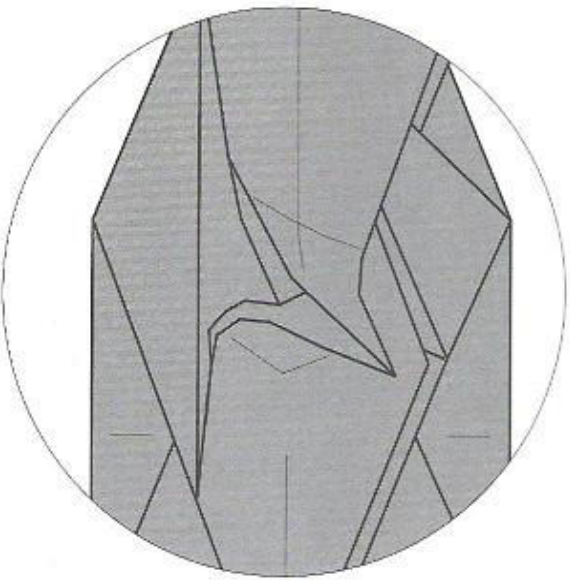
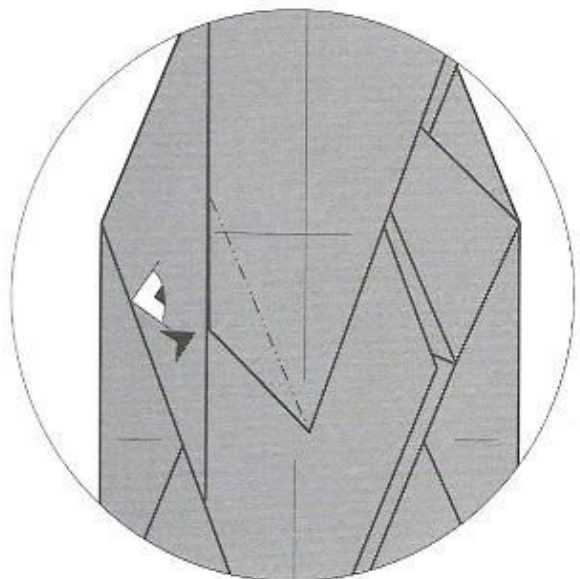
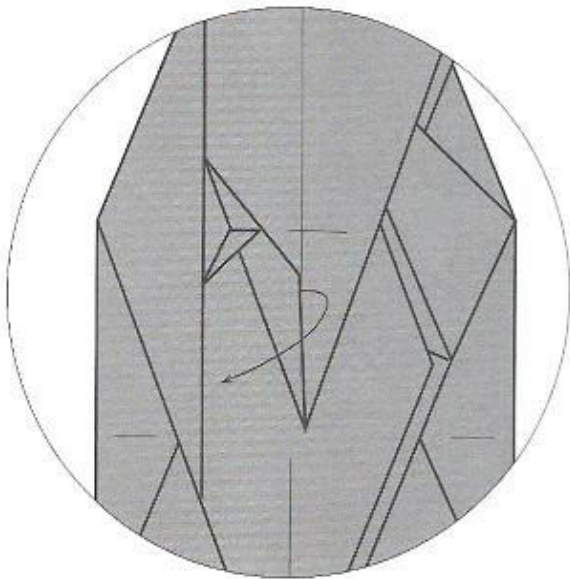
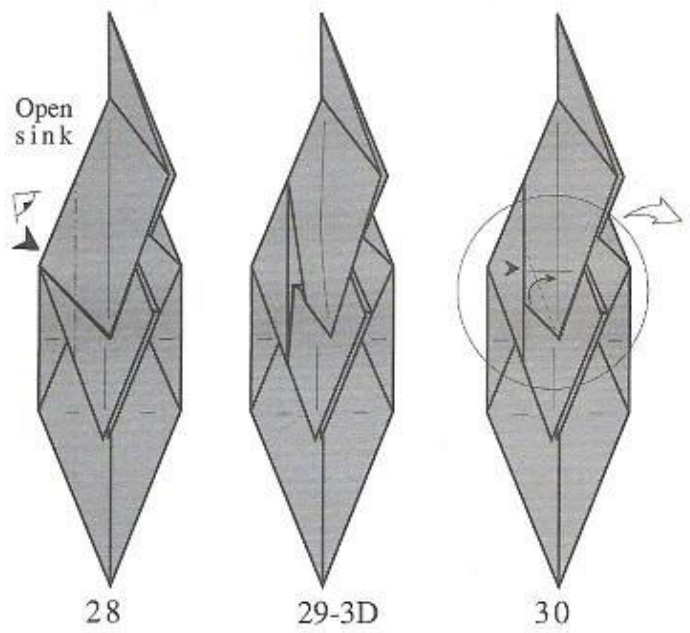
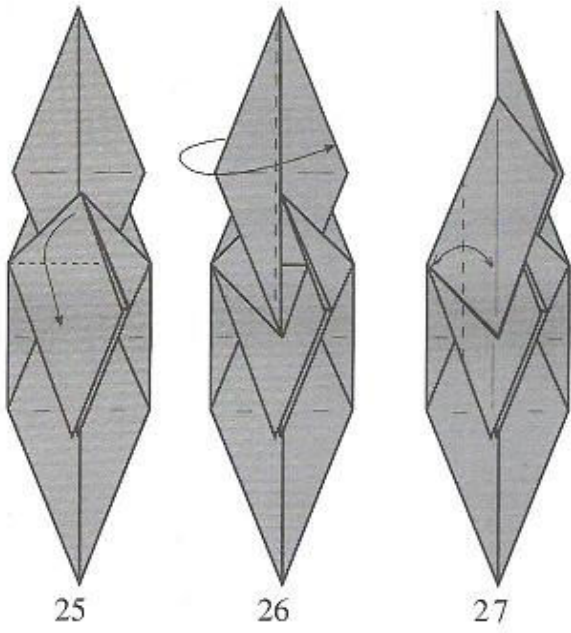

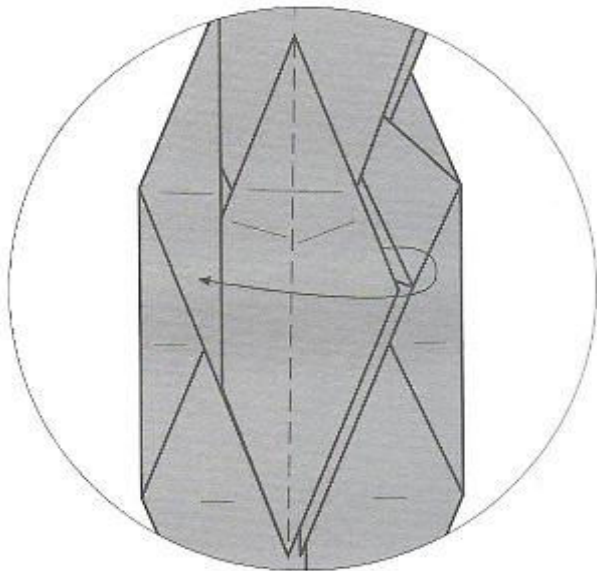

35

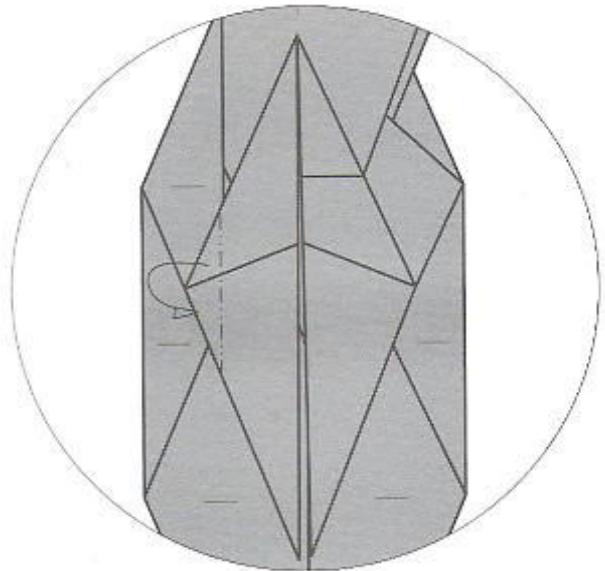

36

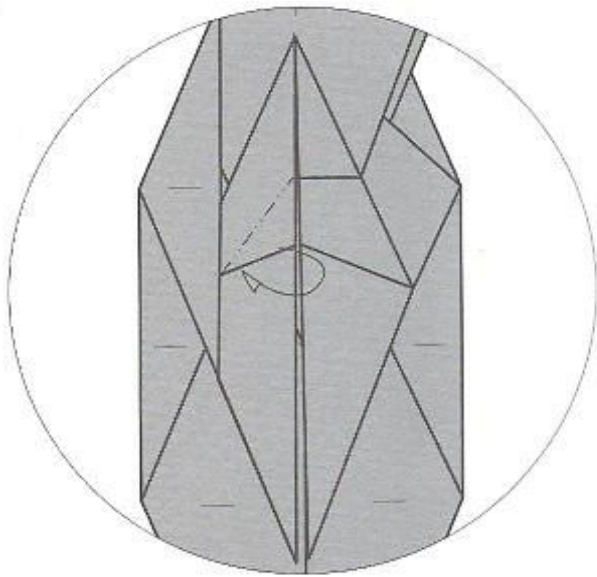

37

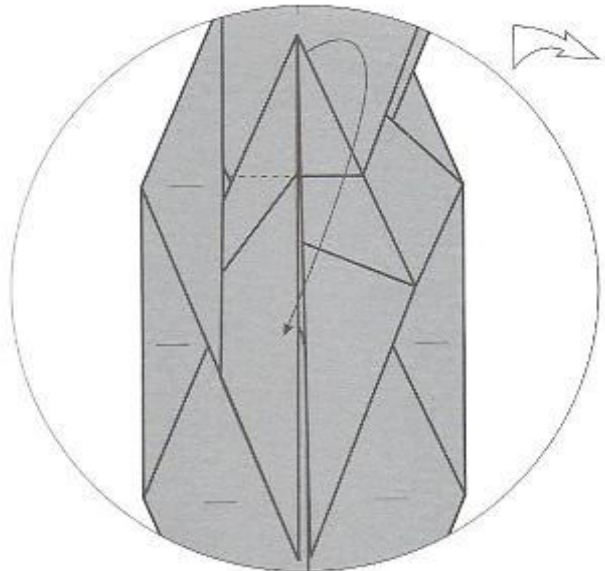

38

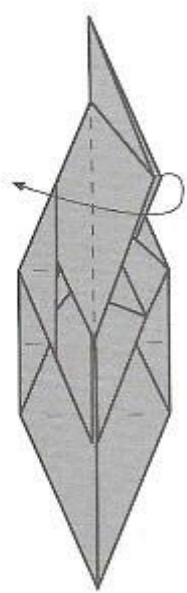

39



40

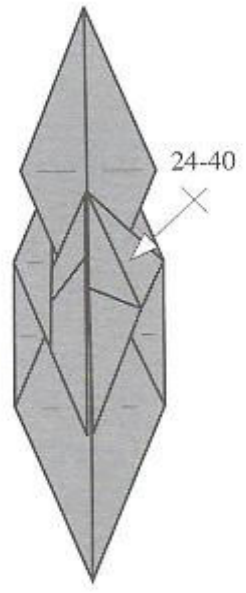

41

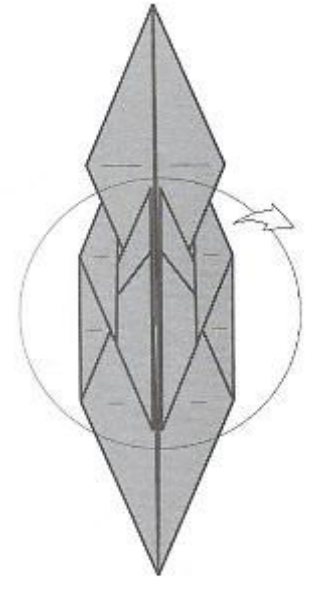

42

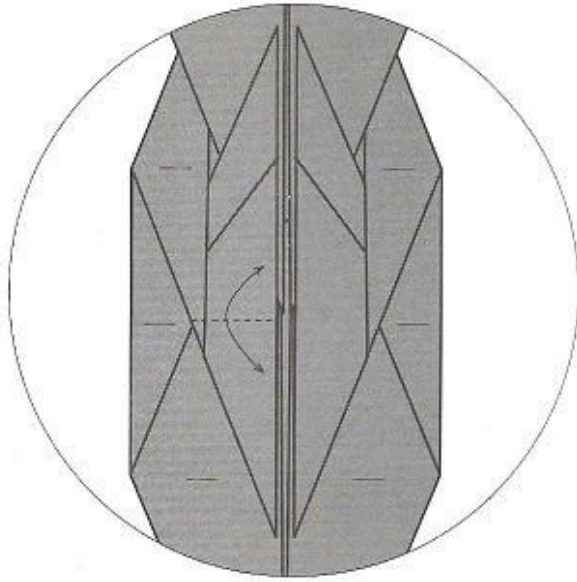

43

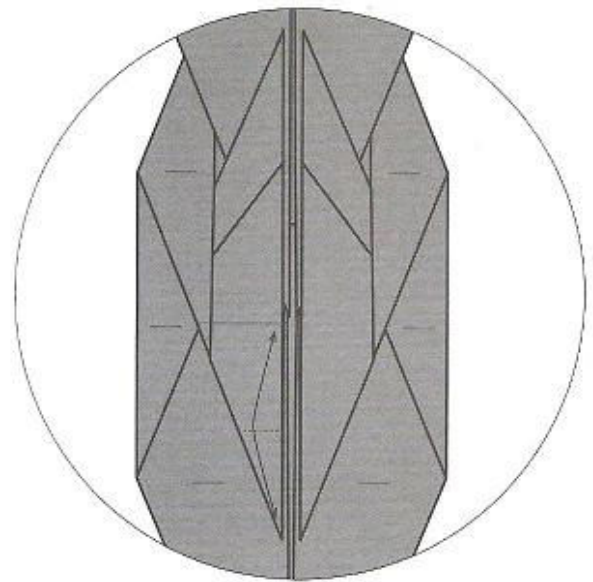

44

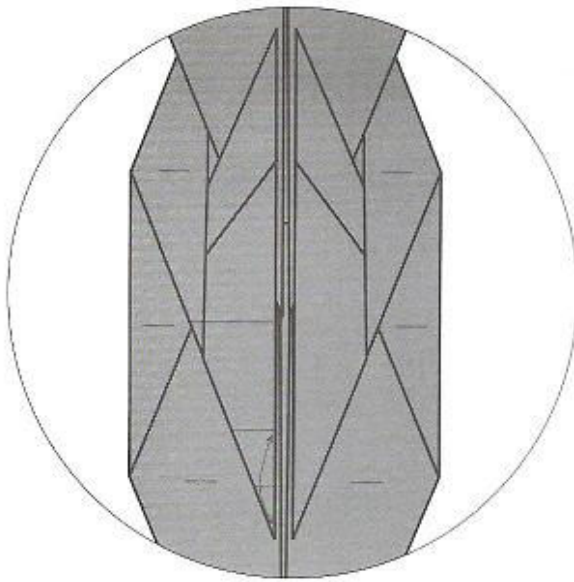

45

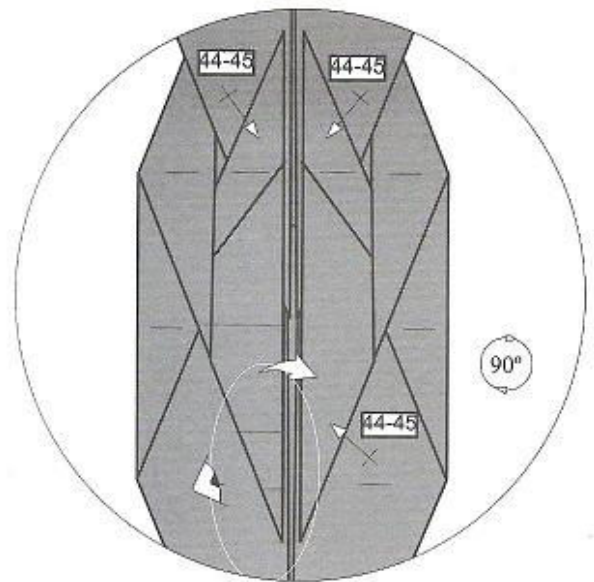

46

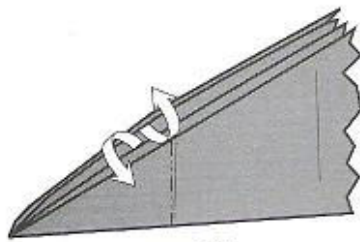

47

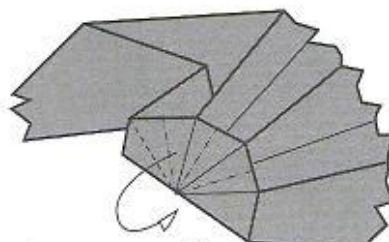

48

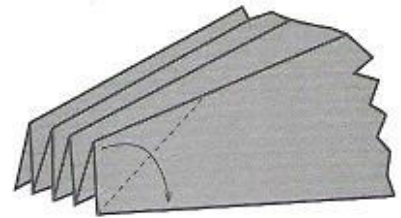

49

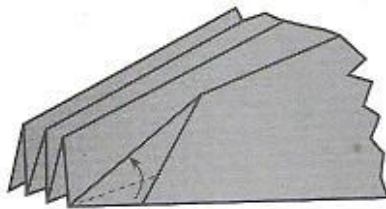

50

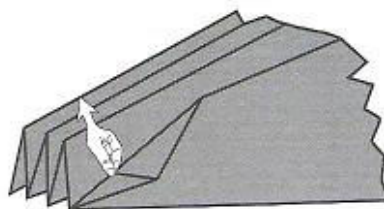

51

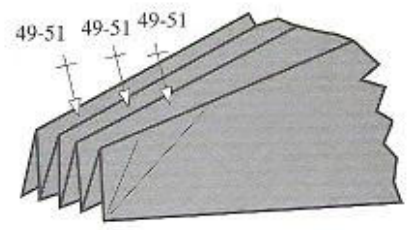

52

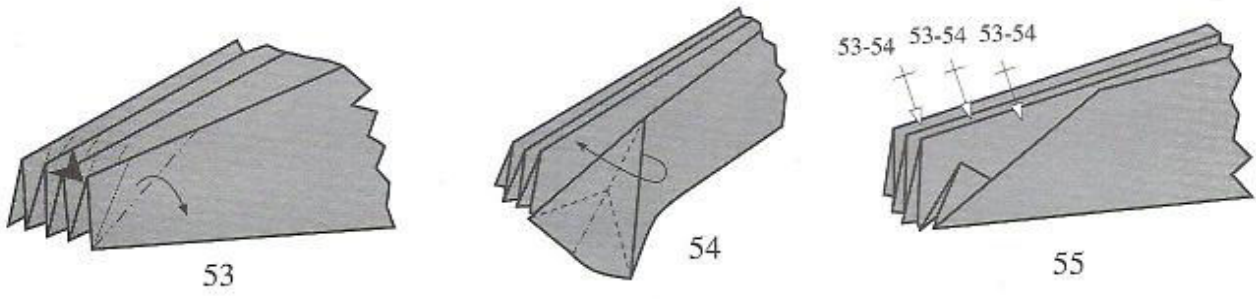

53

54

55

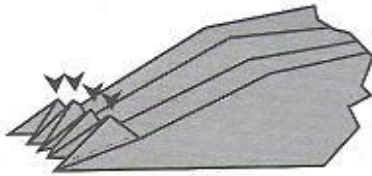

56

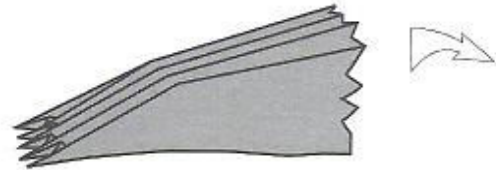

57

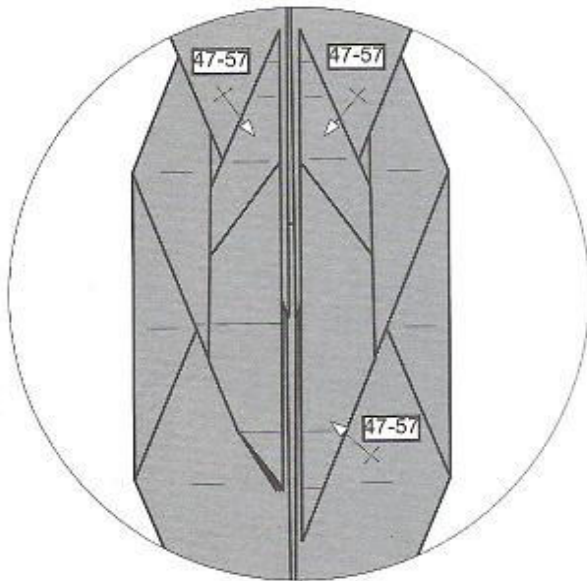

58

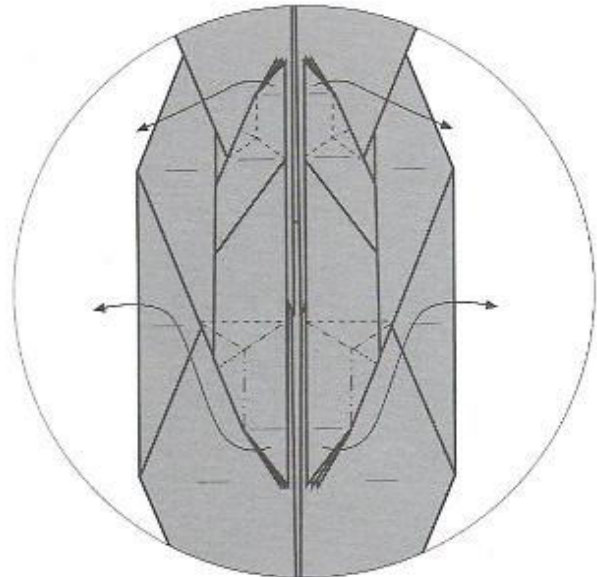

59

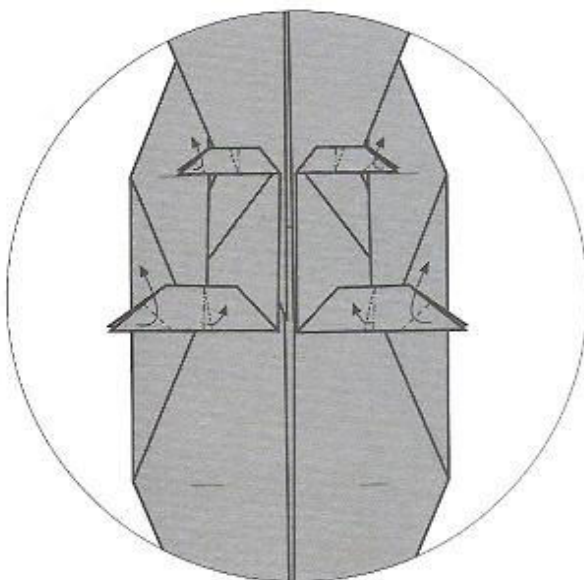

60

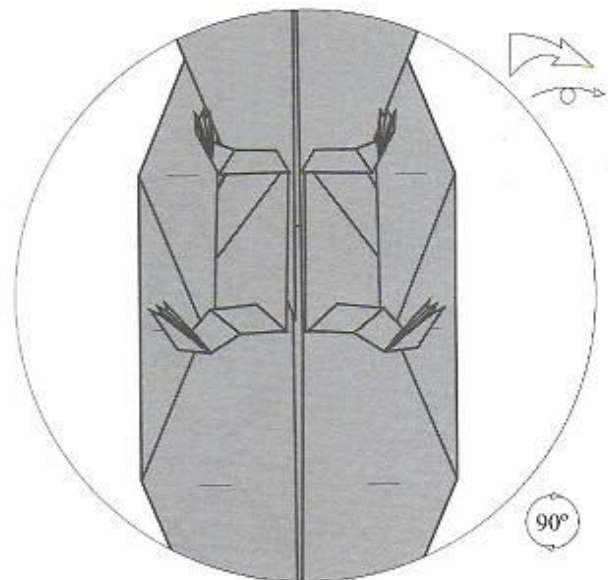

61

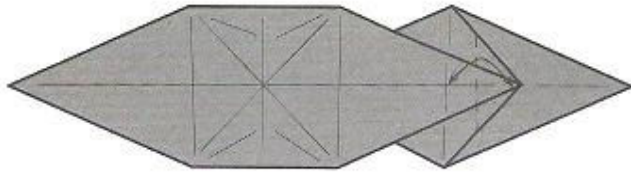

62

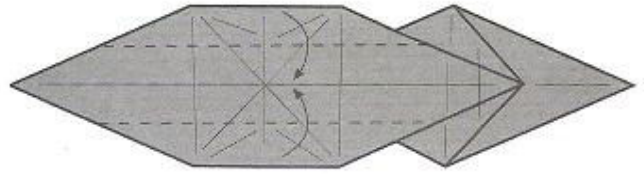

63

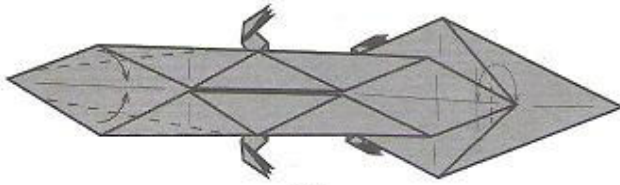

64

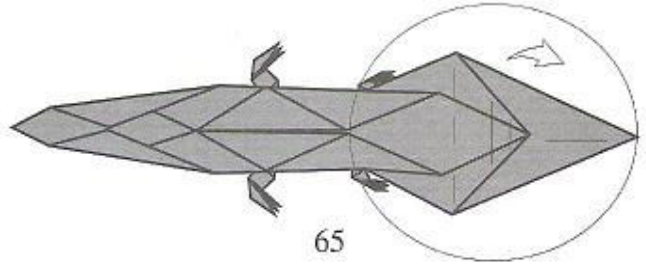

65

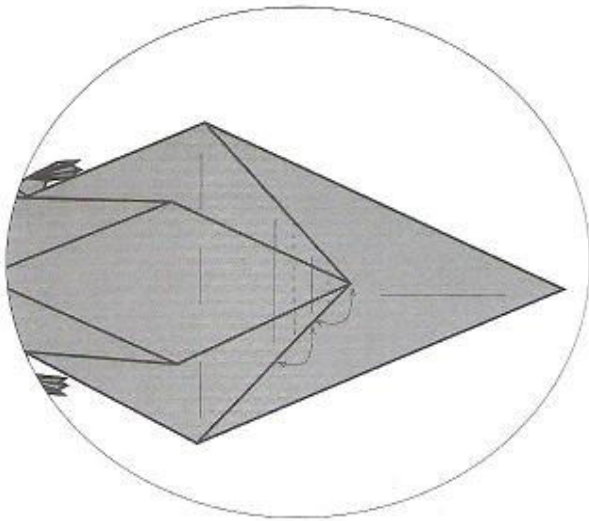

66

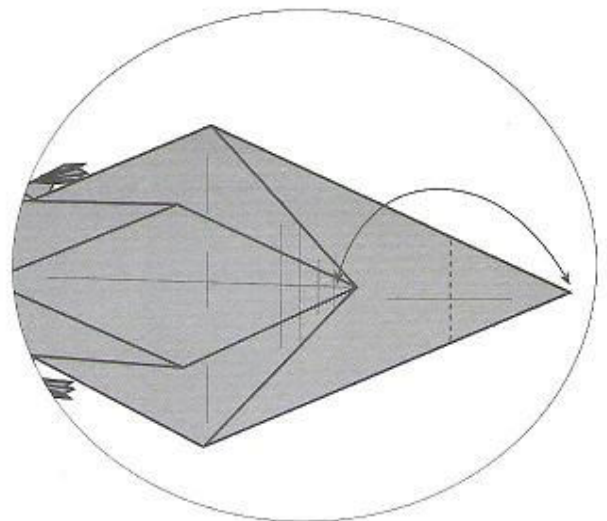

67

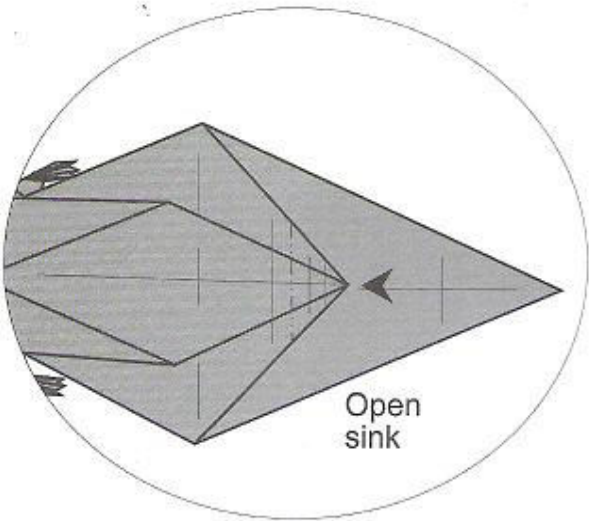

Open
sink

68

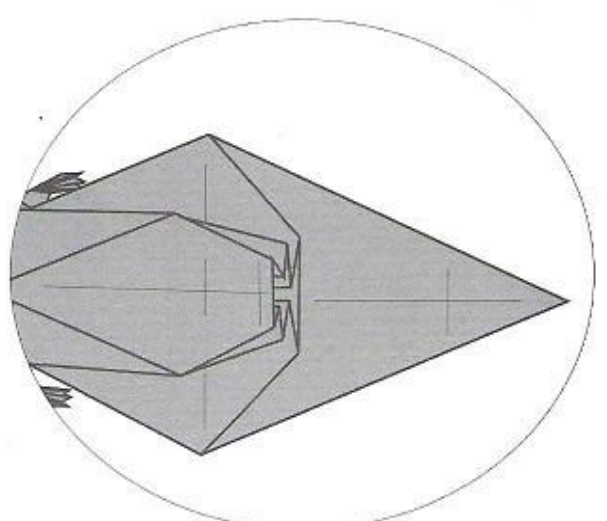

69-3D

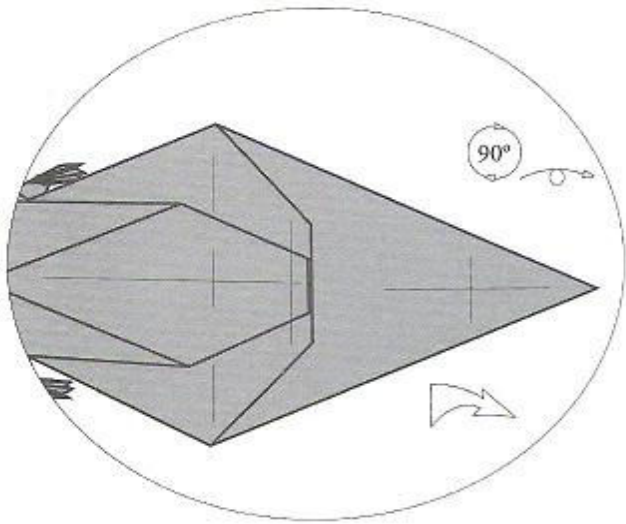

70

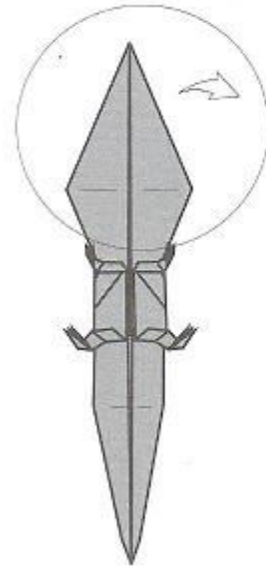

71

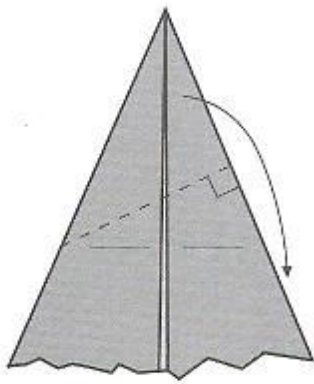

72

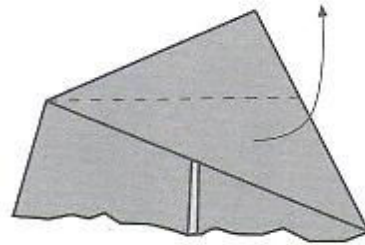

73

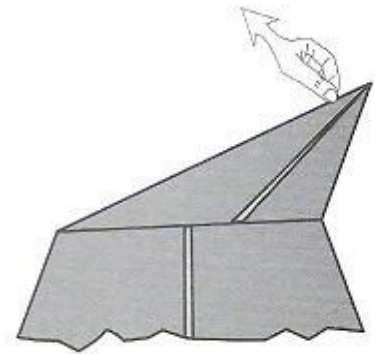

74

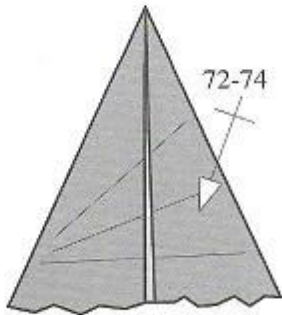

75

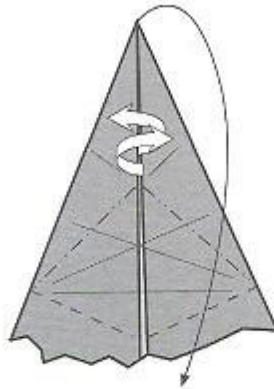

76

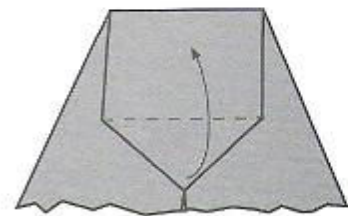

77

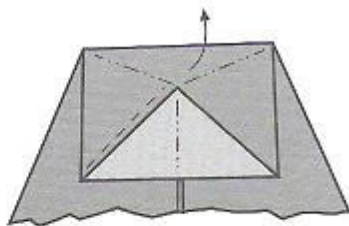

78

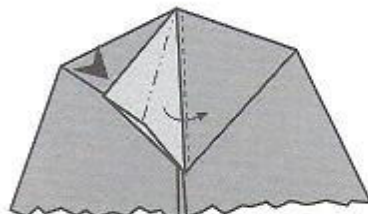

79

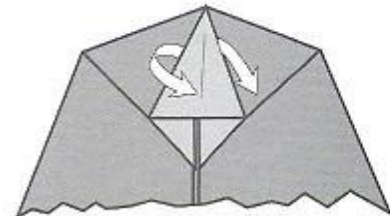

80

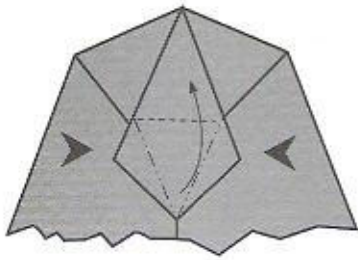

81

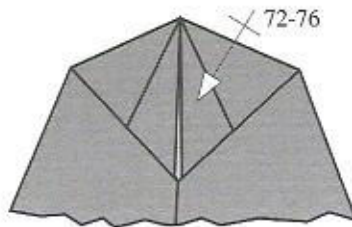

82



83

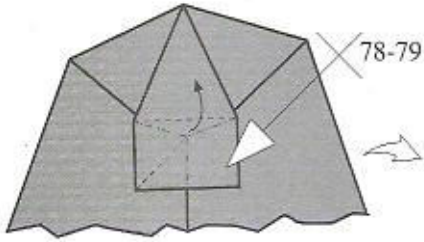

84

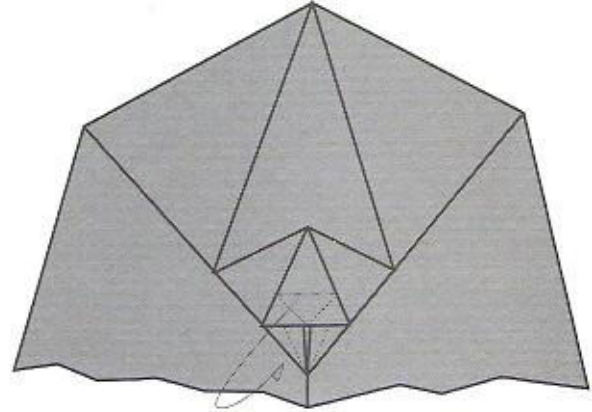

85

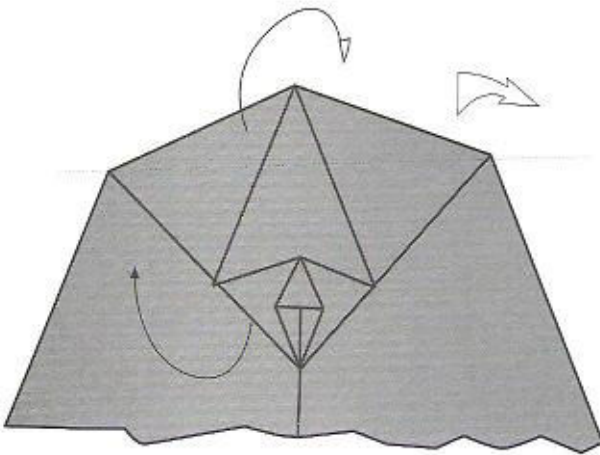

86

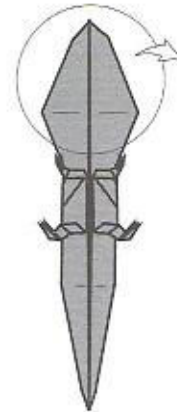

87

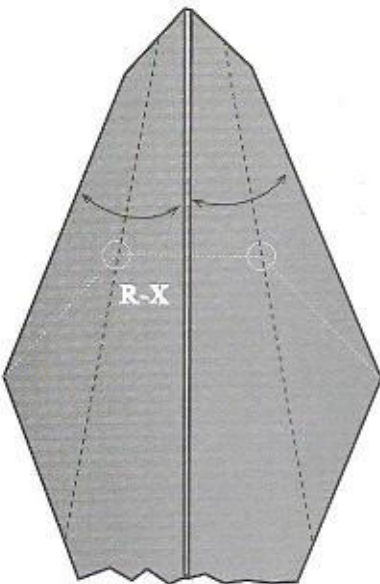

88

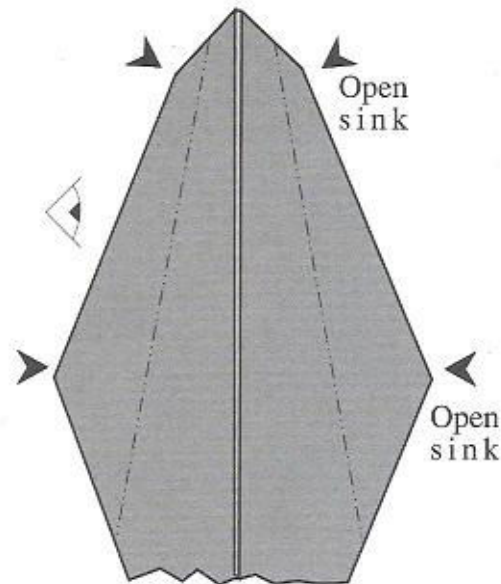

89

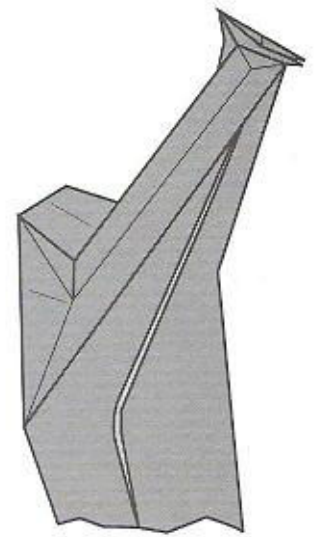

90-3D

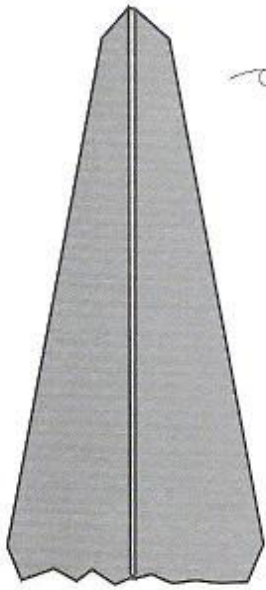

91

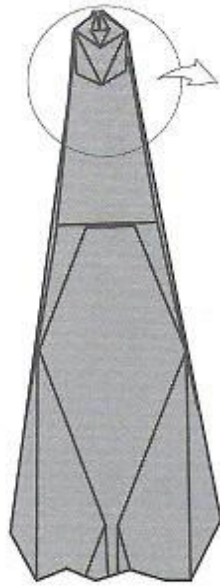

92

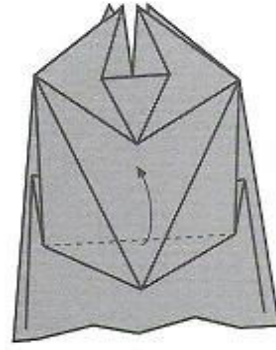

93

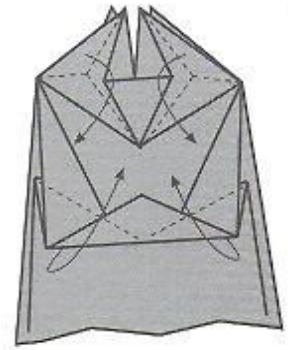

94

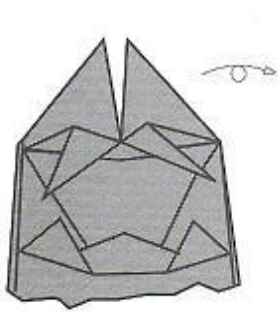

95

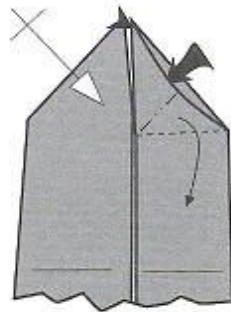

96

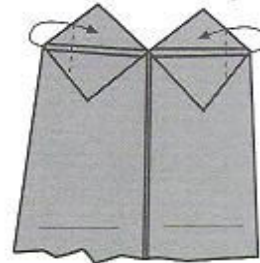

97

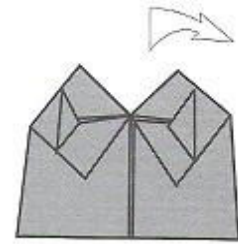

98

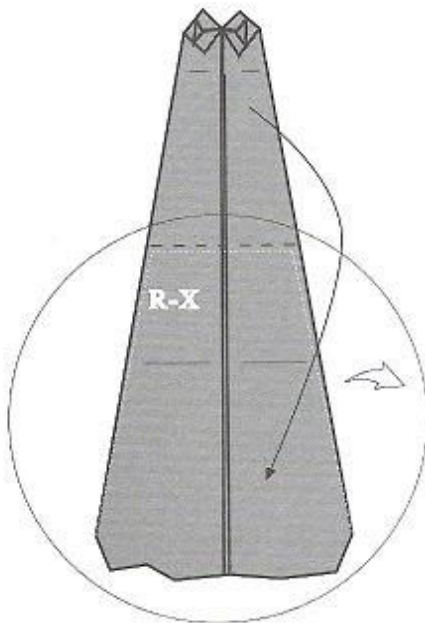

99

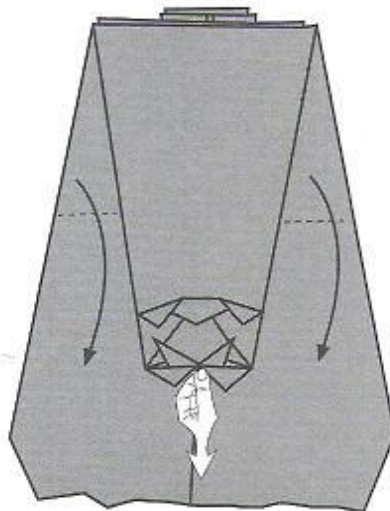

100

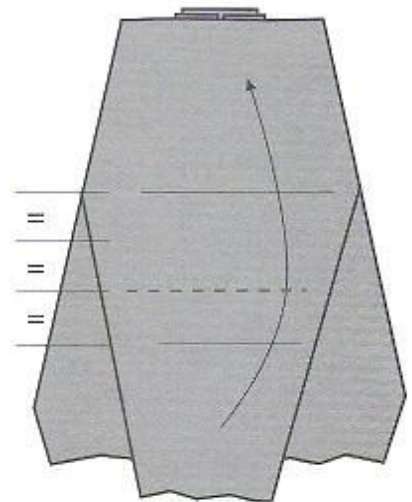

101

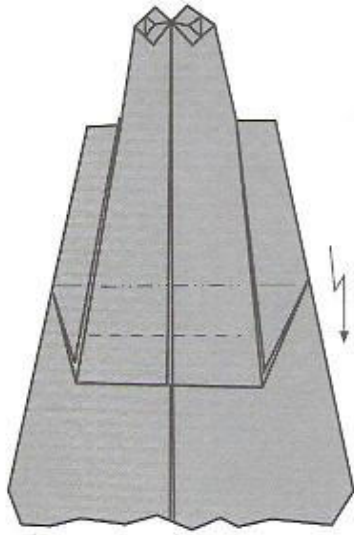

102

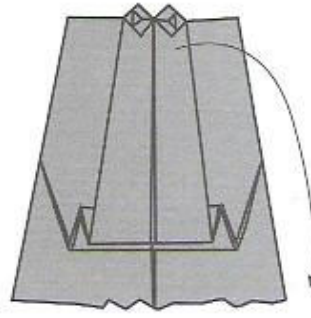

103

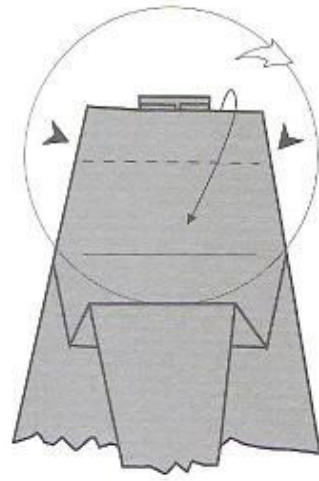

104

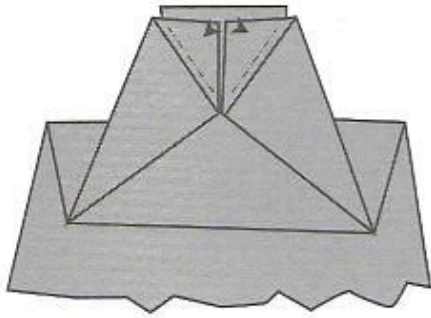

105

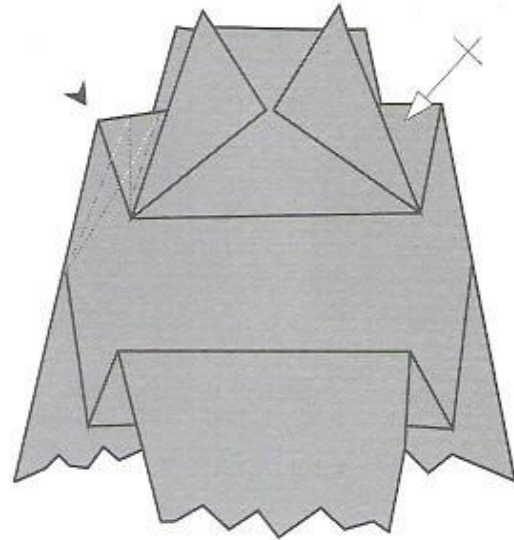

106

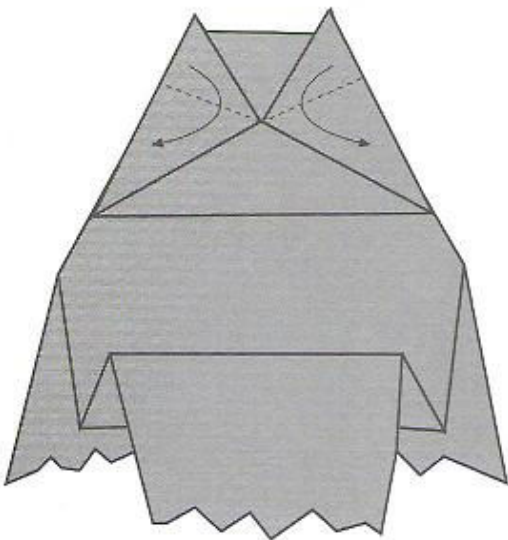

107

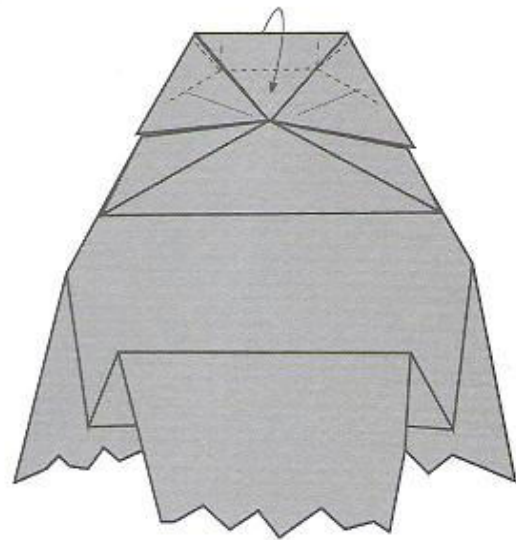

108

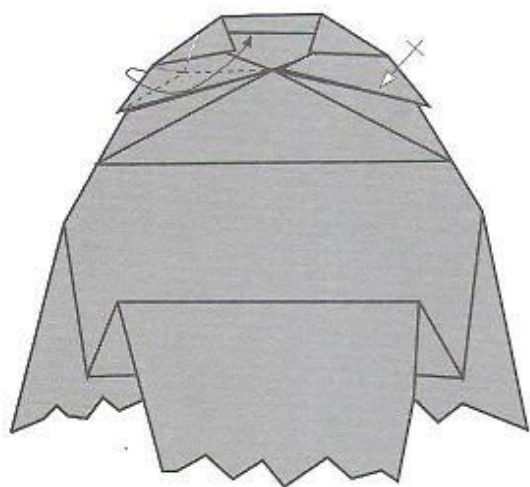

109

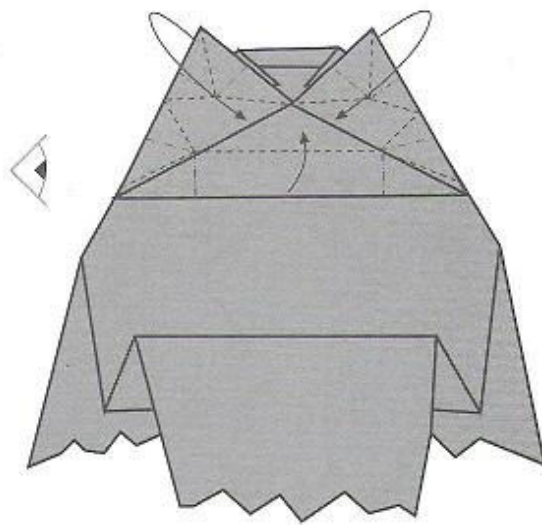

110

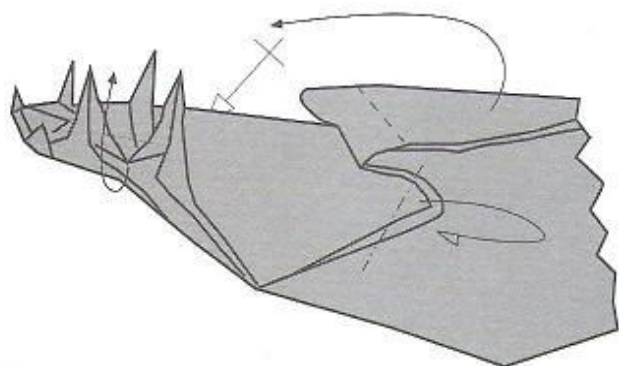

111

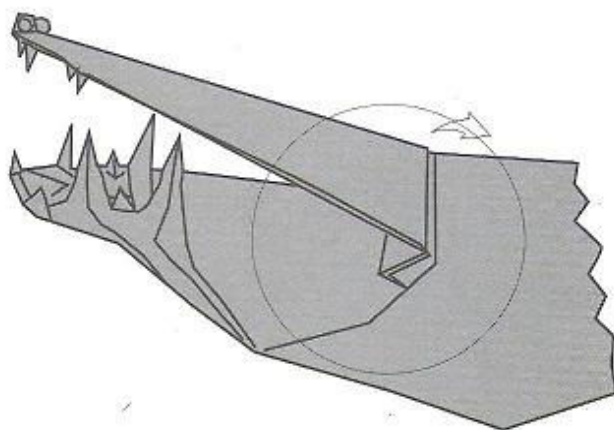

112

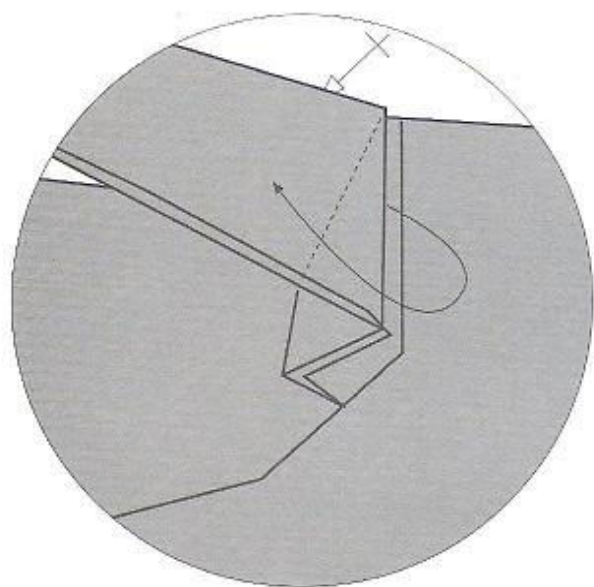

113

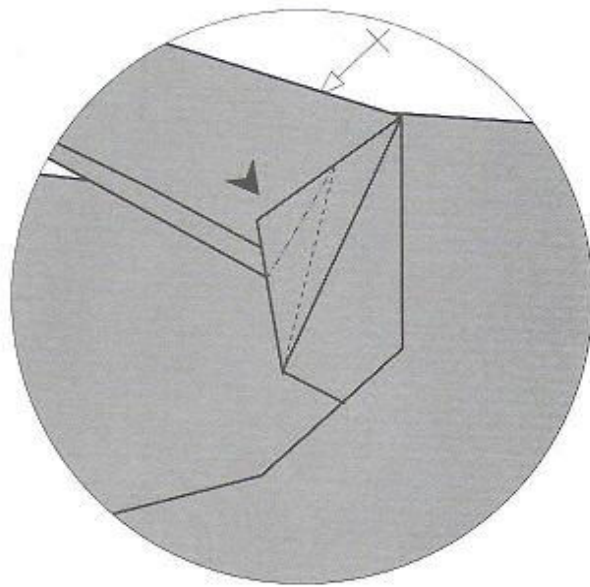

114

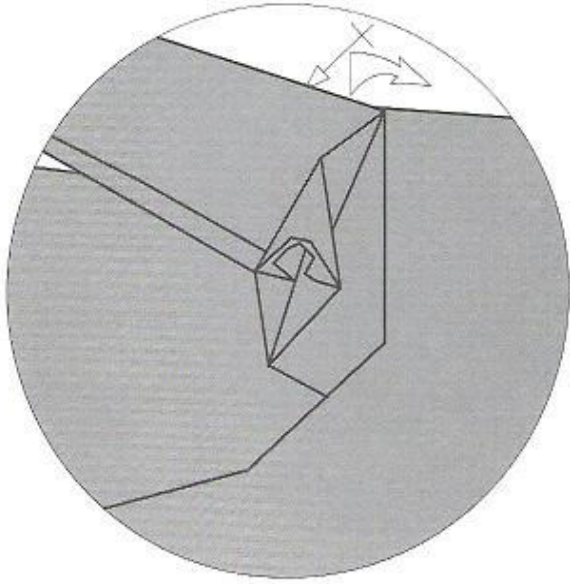

115

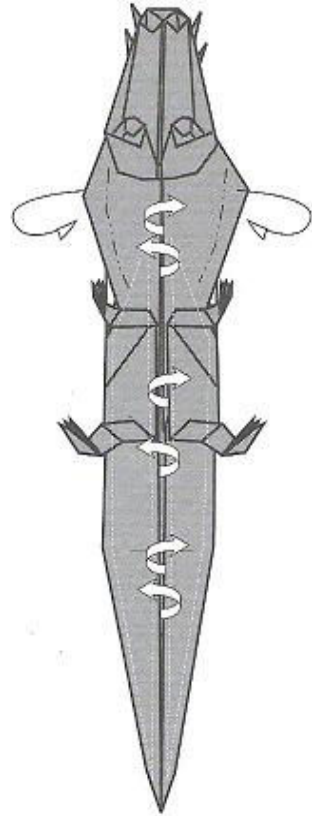

116

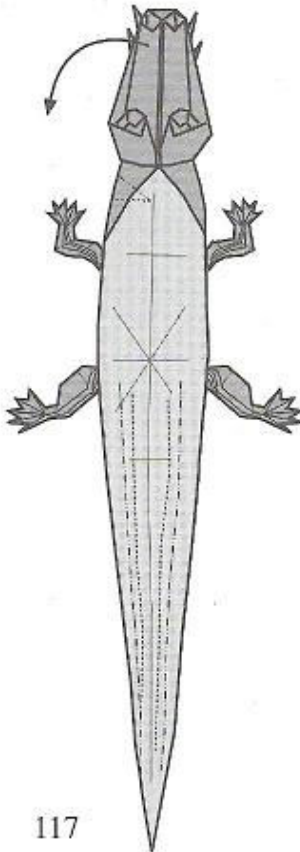

117

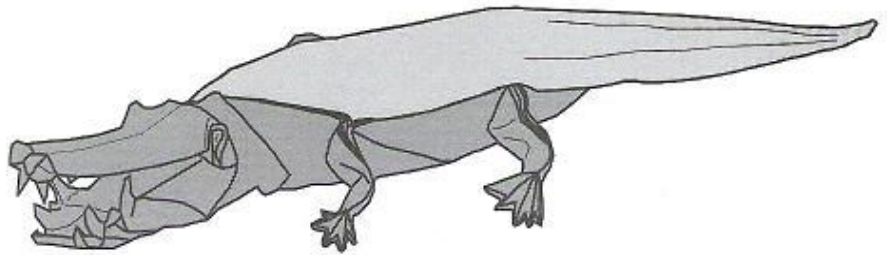

118

Shining Star

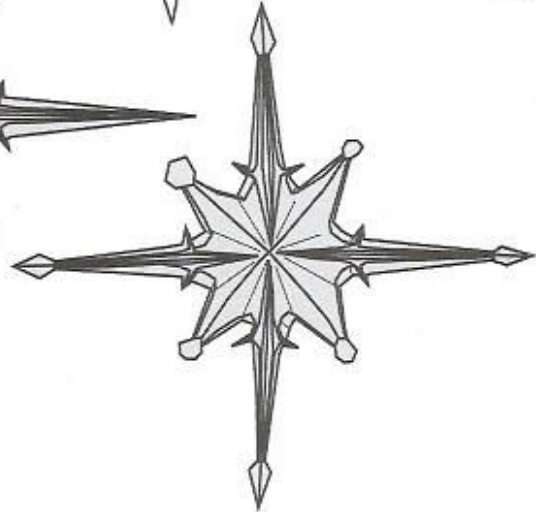
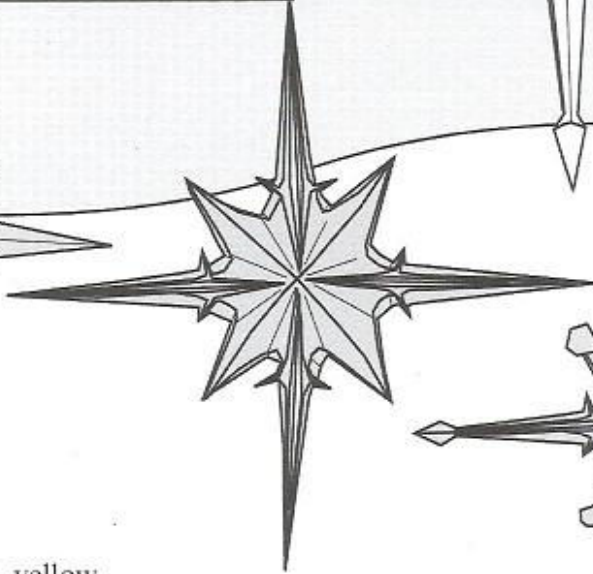
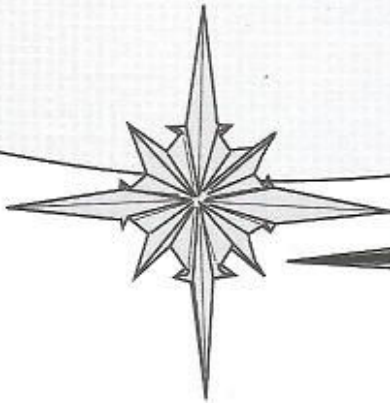
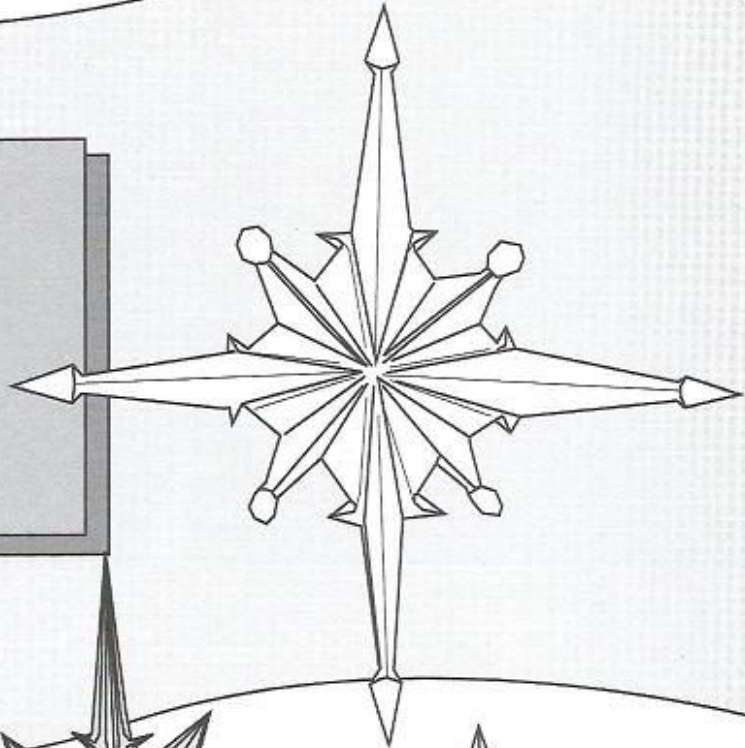

The paper should be yellow, metallic gold or silver. The type of recommended paper is less than 80 grams.

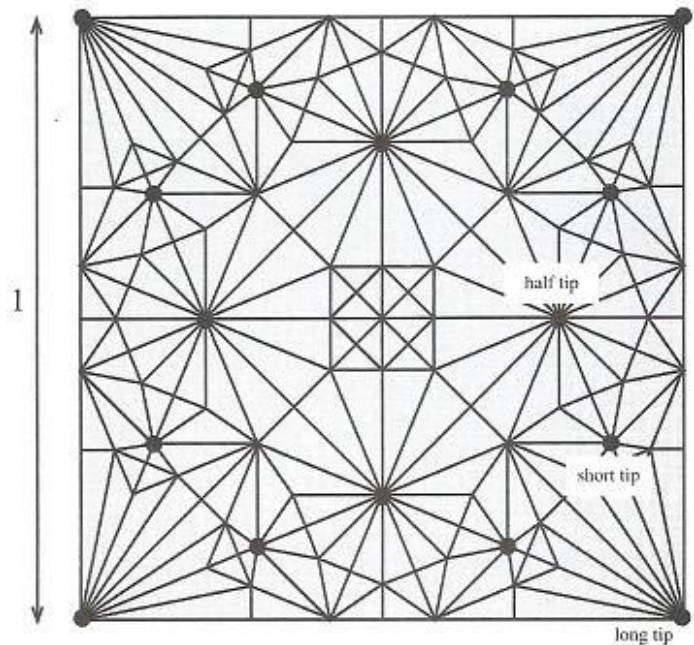
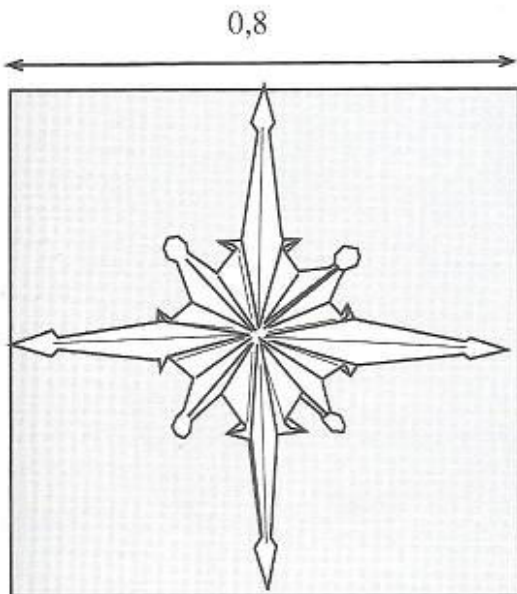

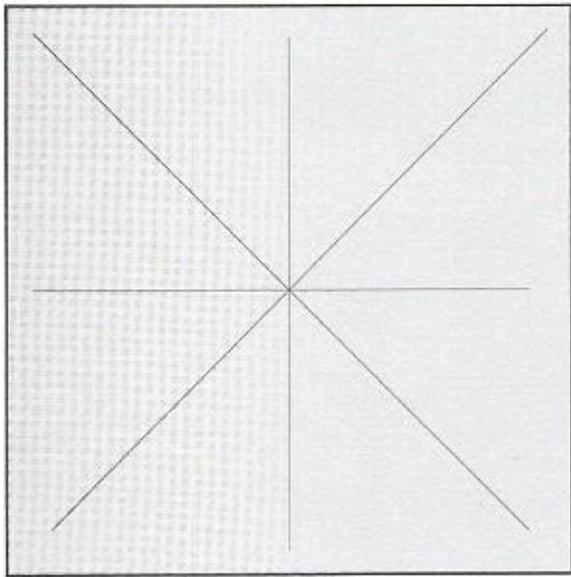

1 ⊕ Gold or silver

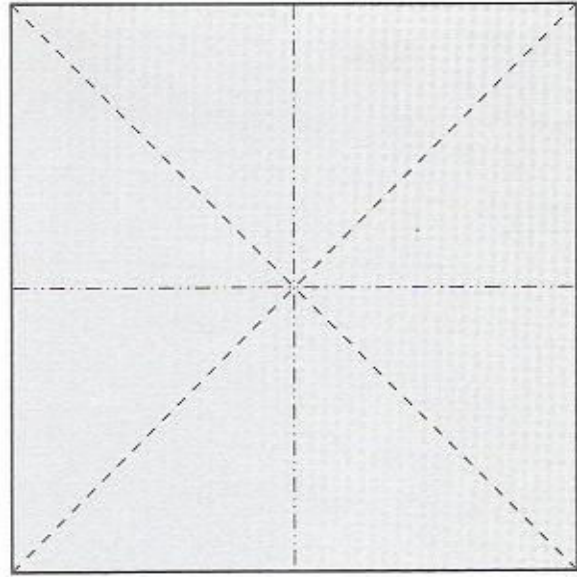

2

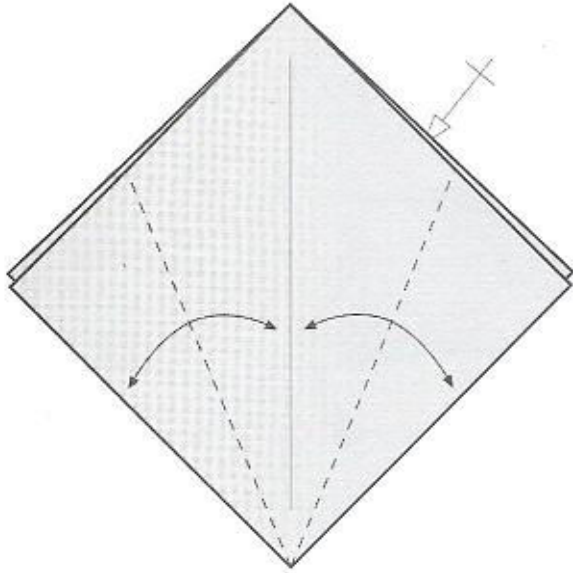

3

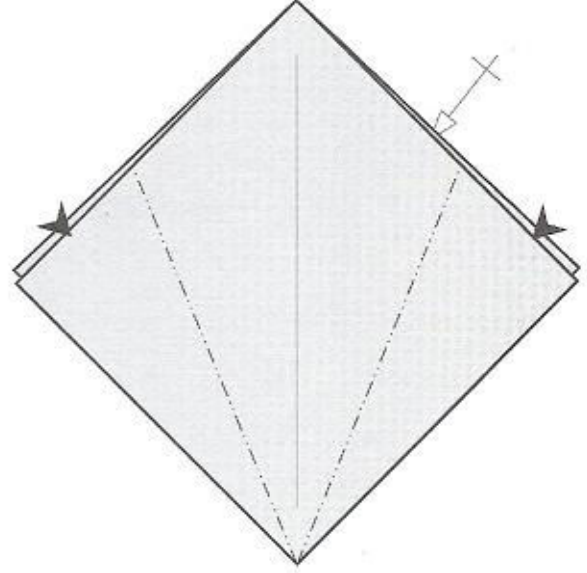

4

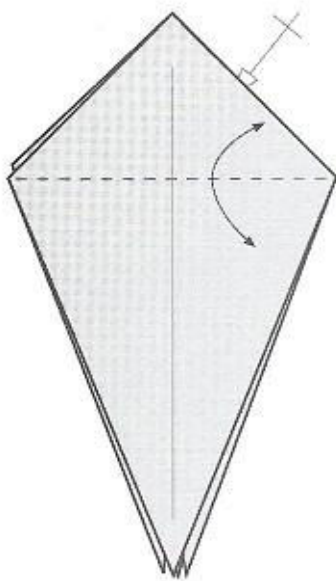

5

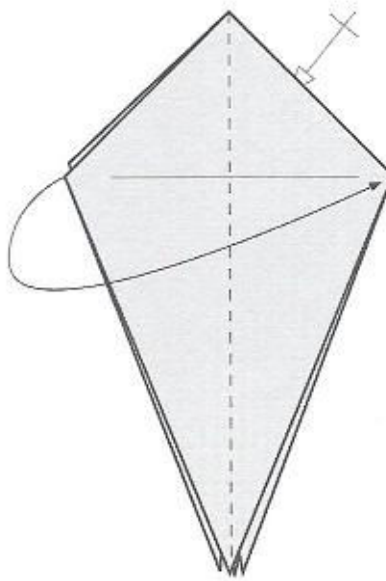

6

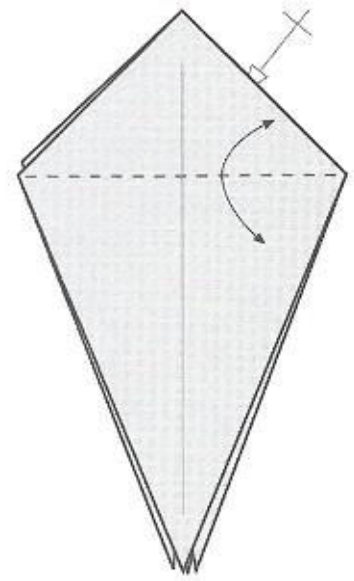

7

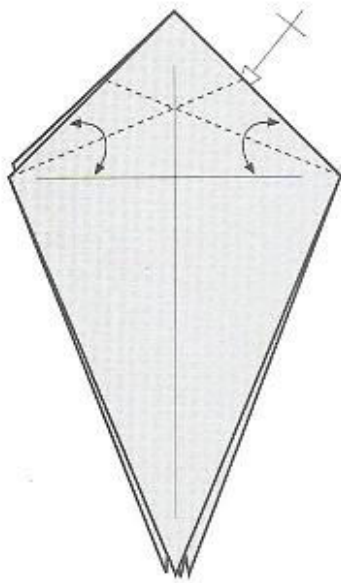

8

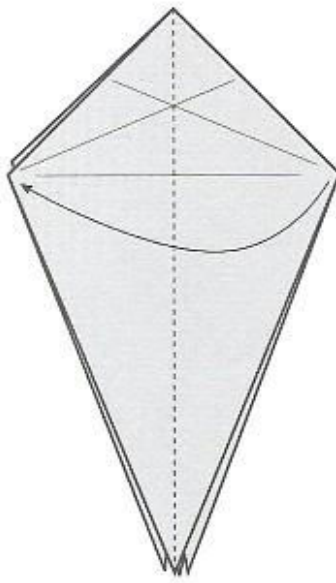

9

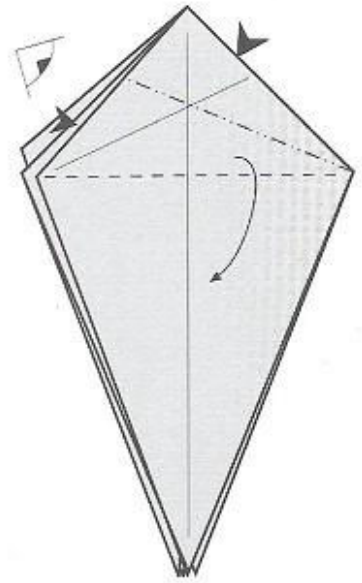

10

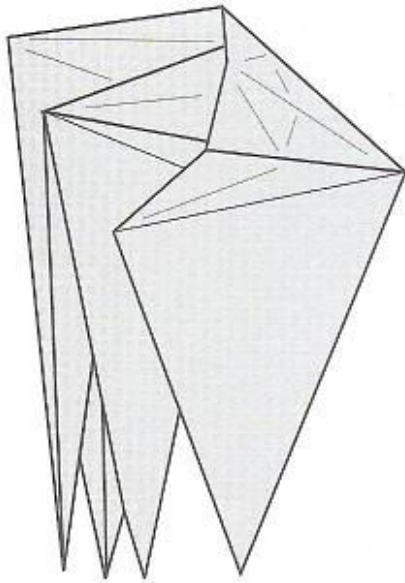

11 3D

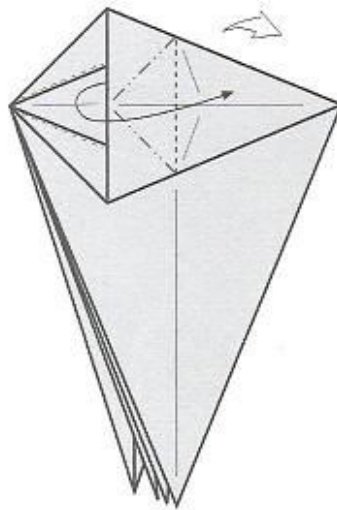

12

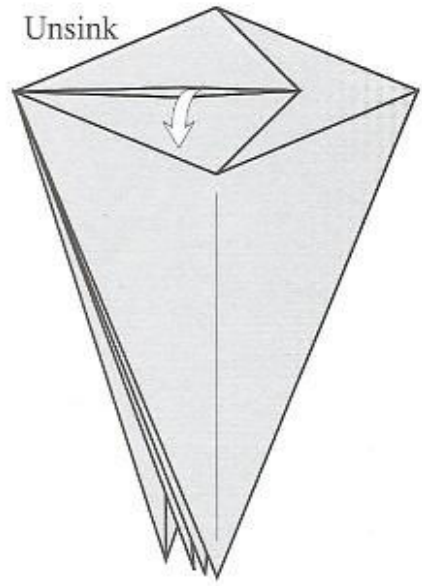

13

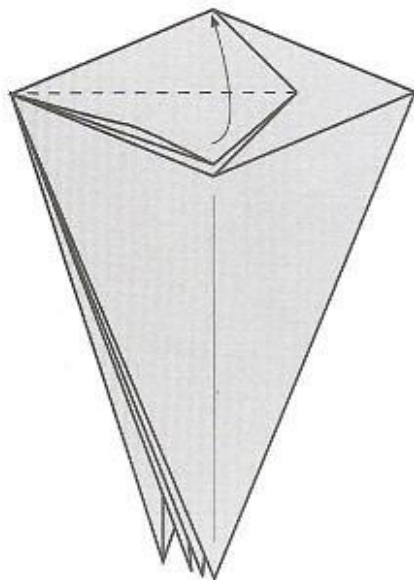

14

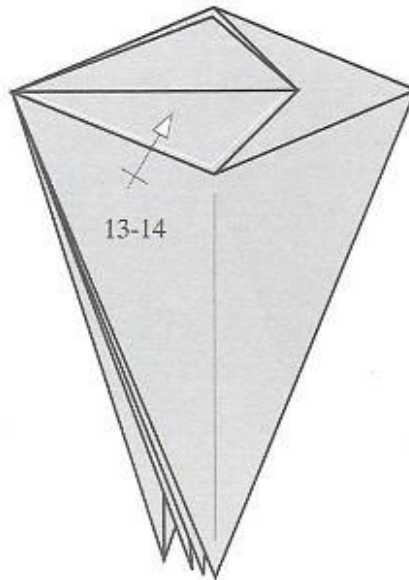

15

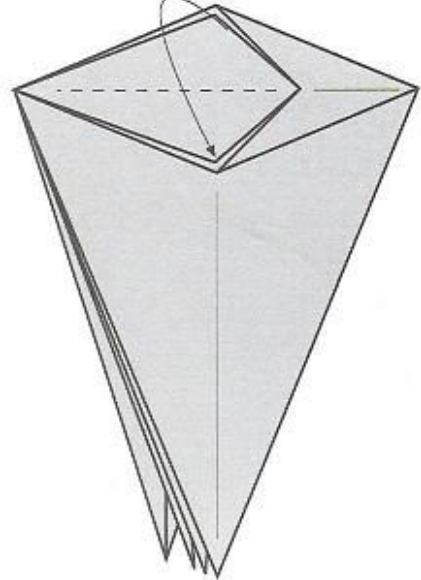

16

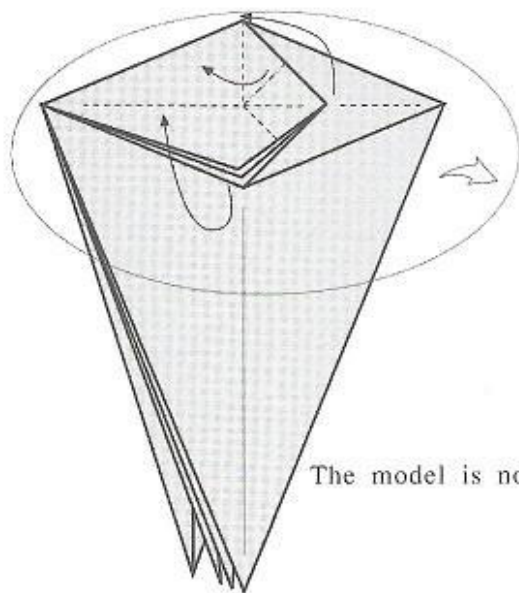

The model is not flat

17

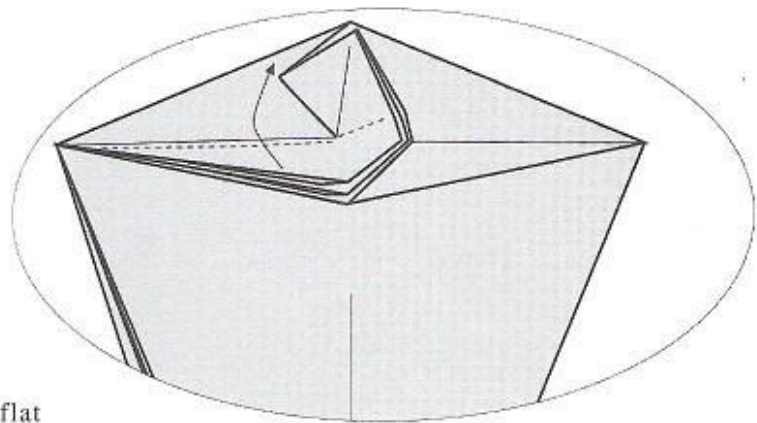

18-3D

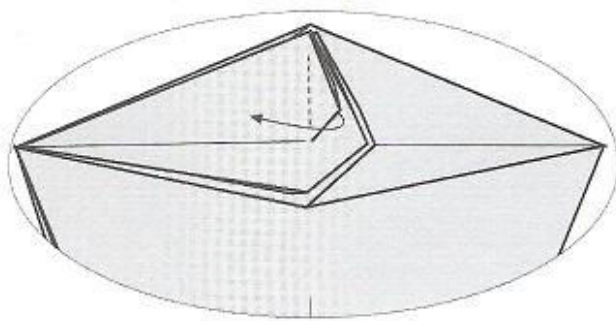

19-3D

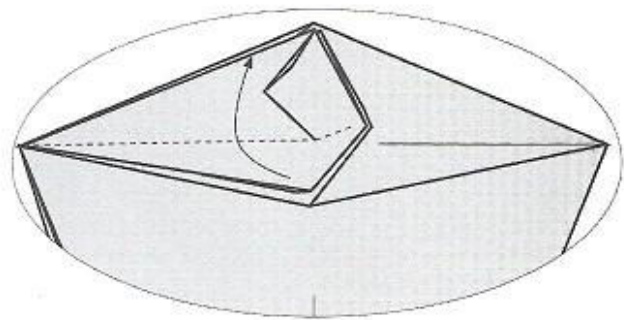

20-3D

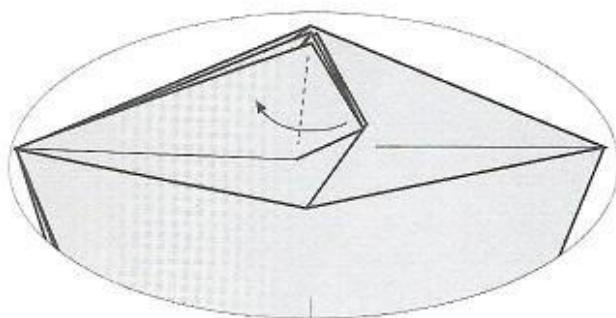

21-3D

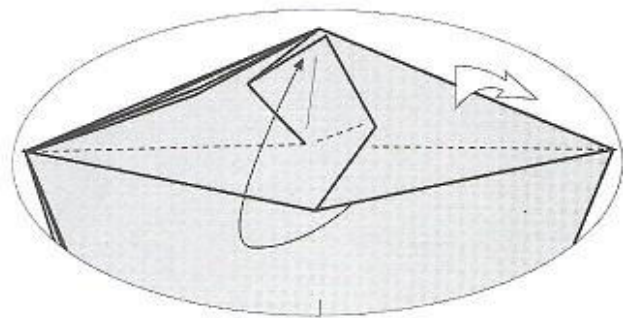

22-3D

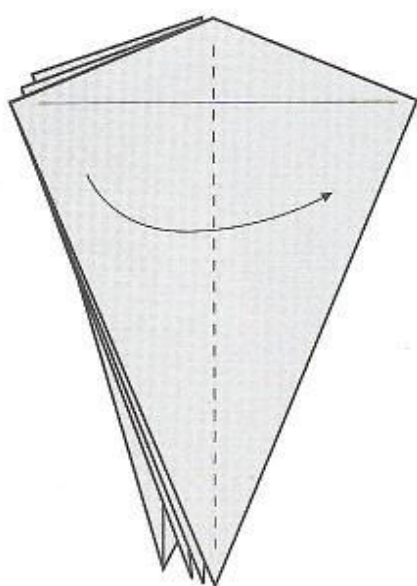

23

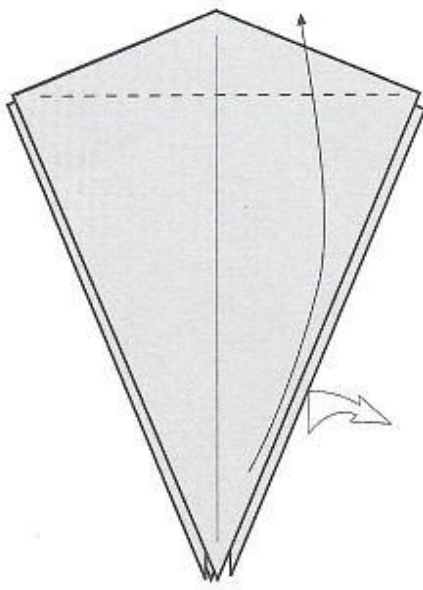

24

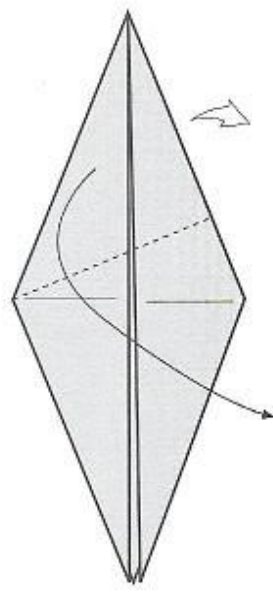

25

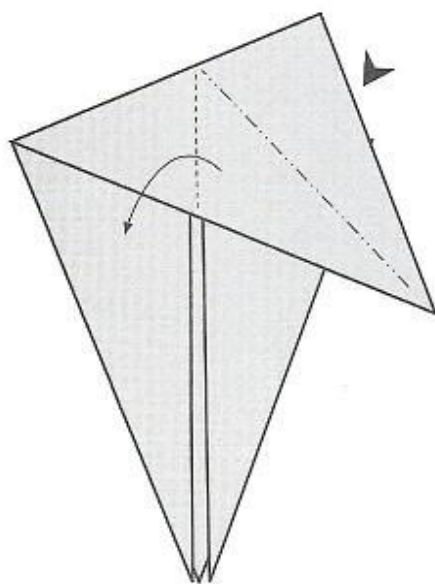

26

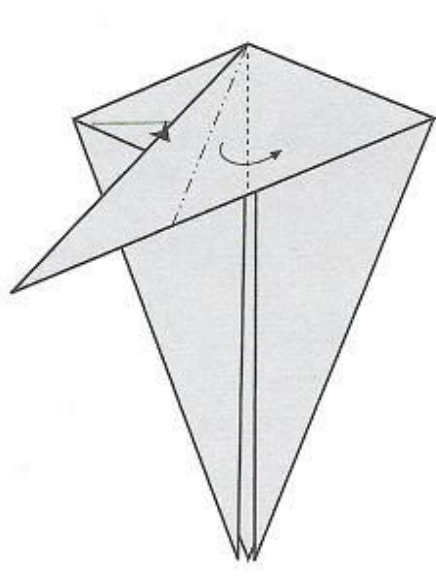

27

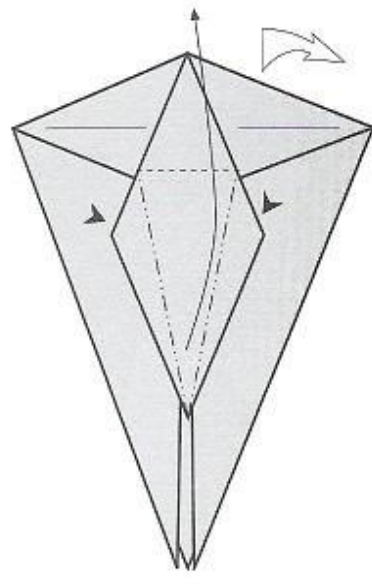

28

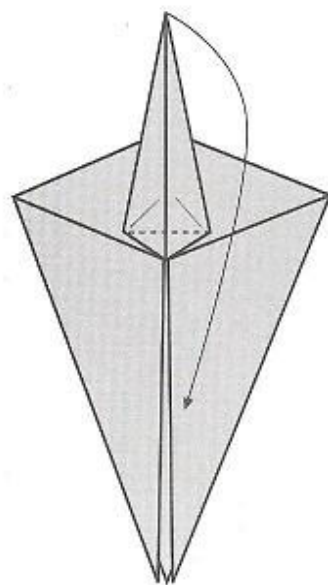

29

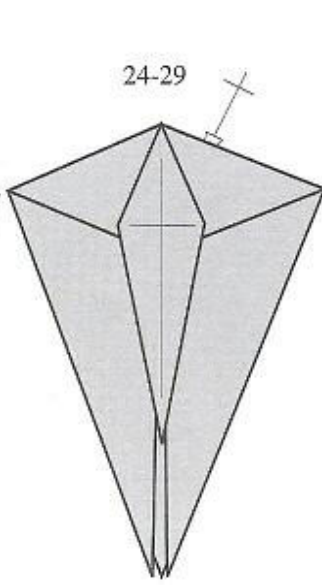

24-29

30

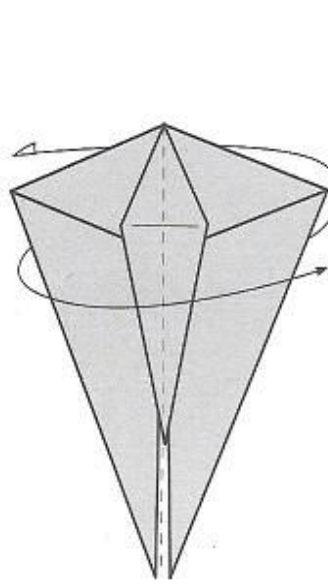

31

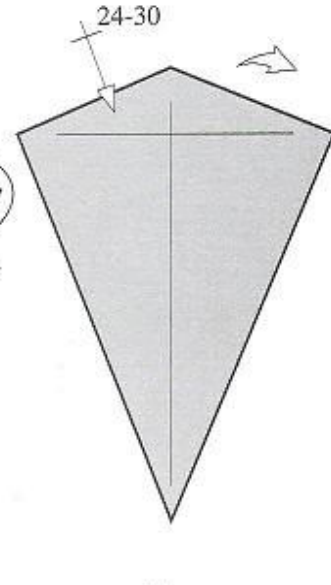

32

24-30

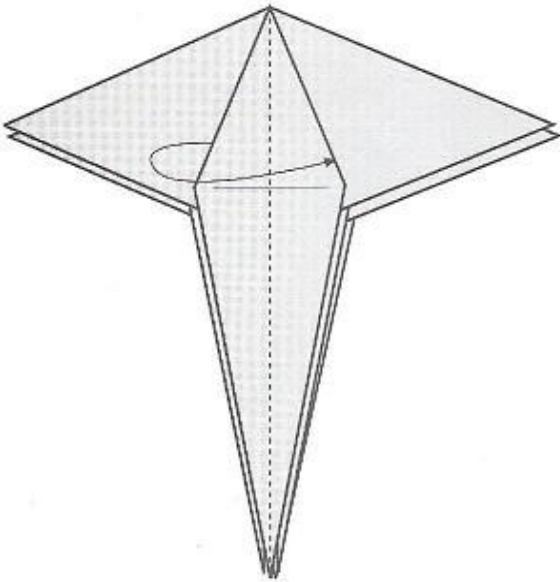

33

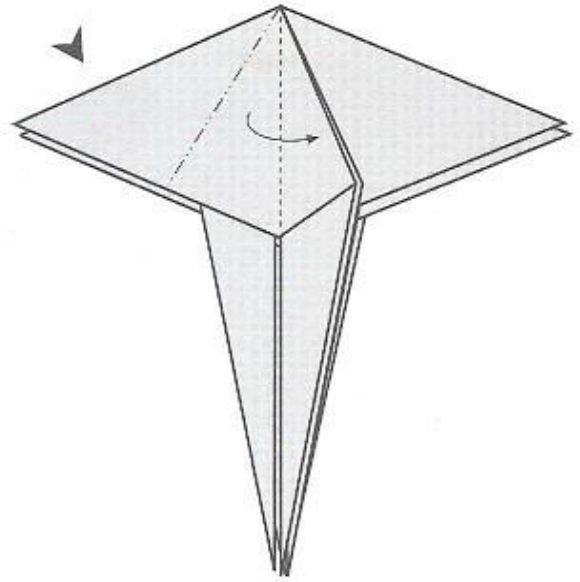

34

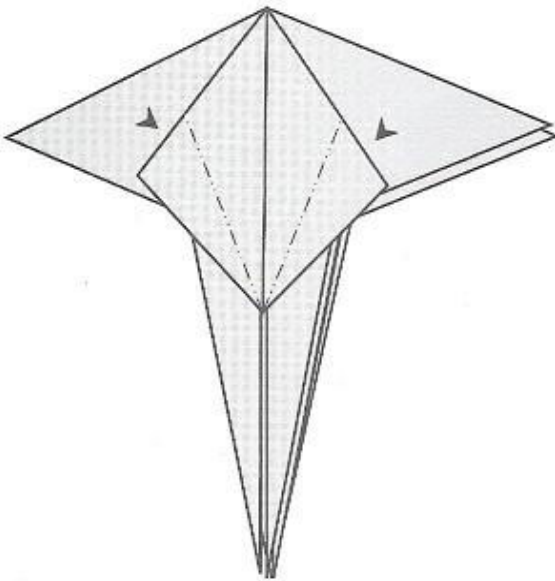

35

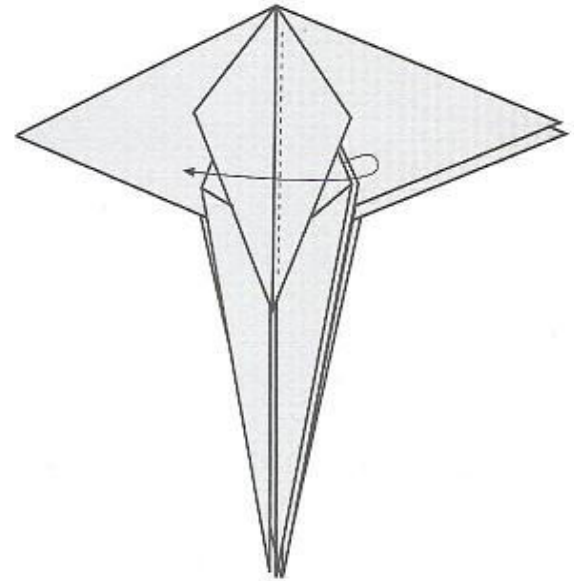

36

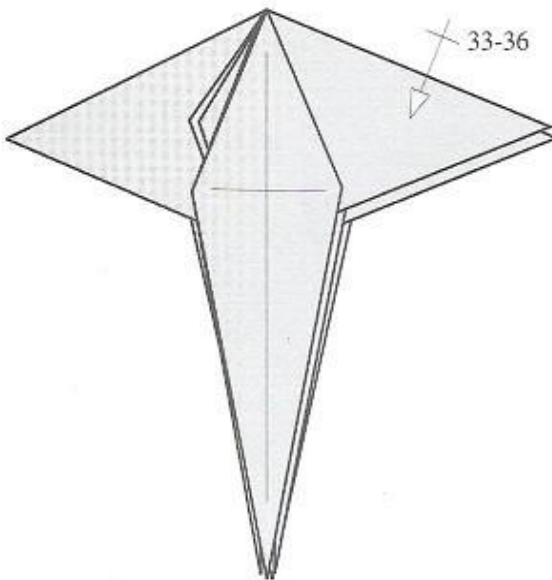

37

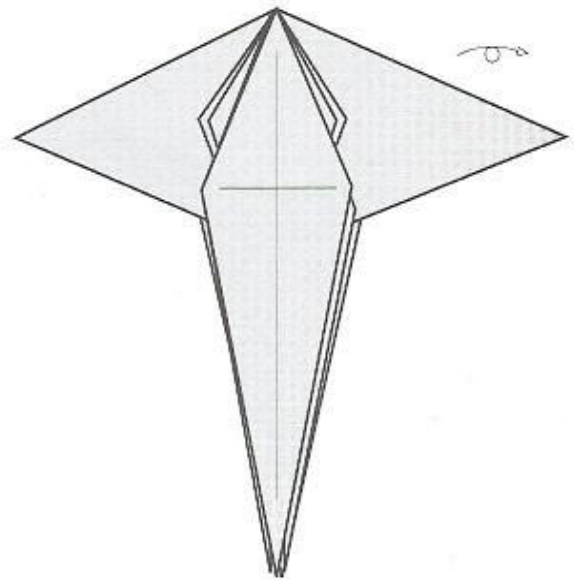

38

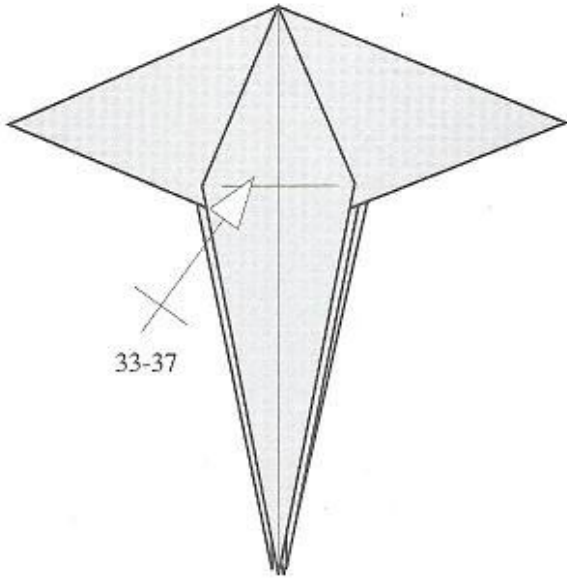

33-37

39

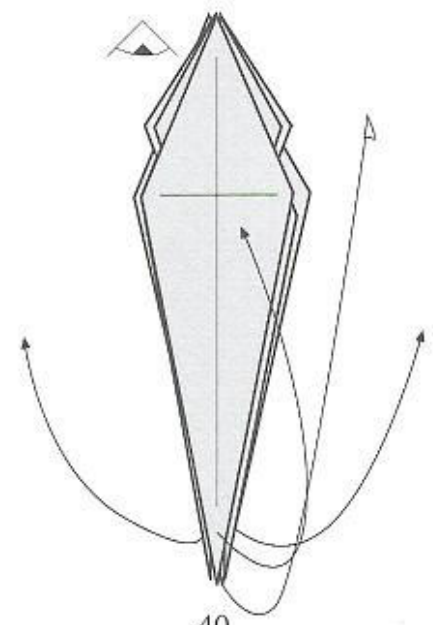

40

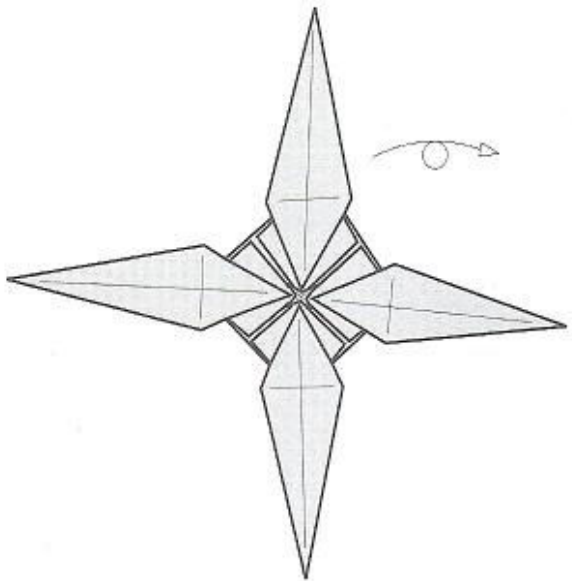

41

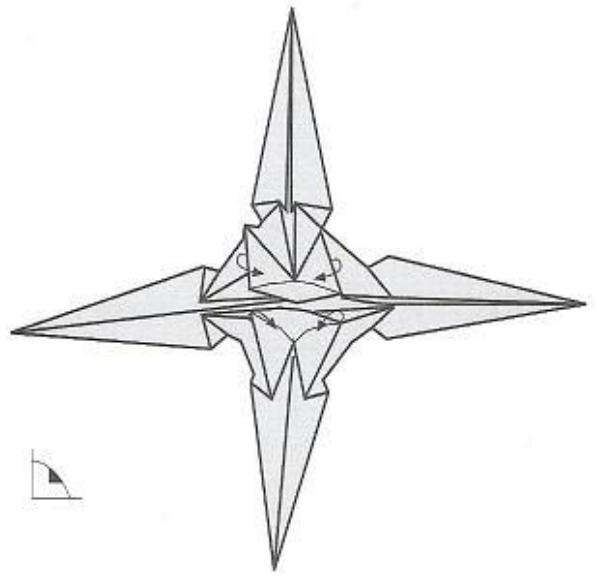

42

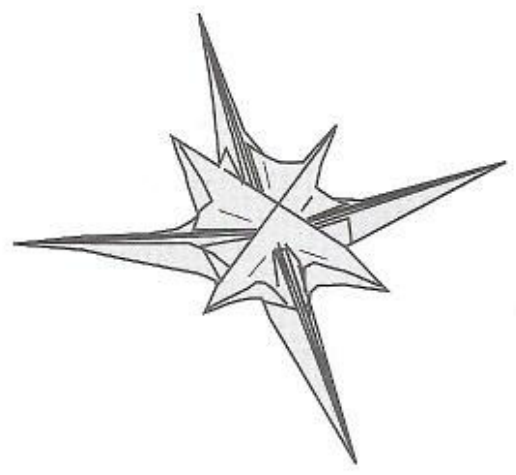

43-3D

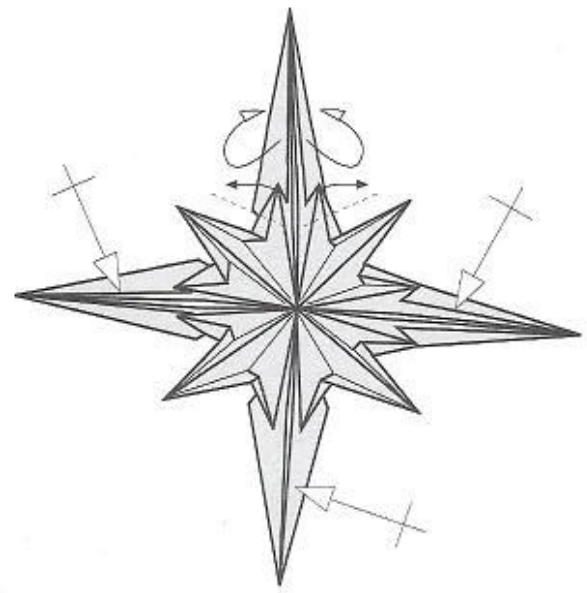

44

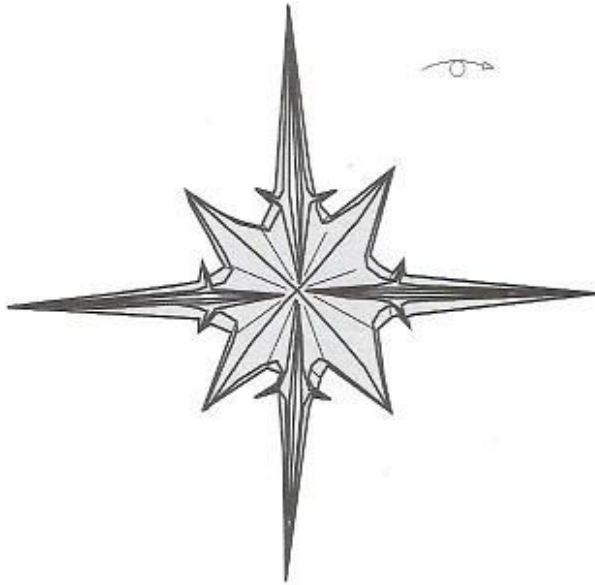

45

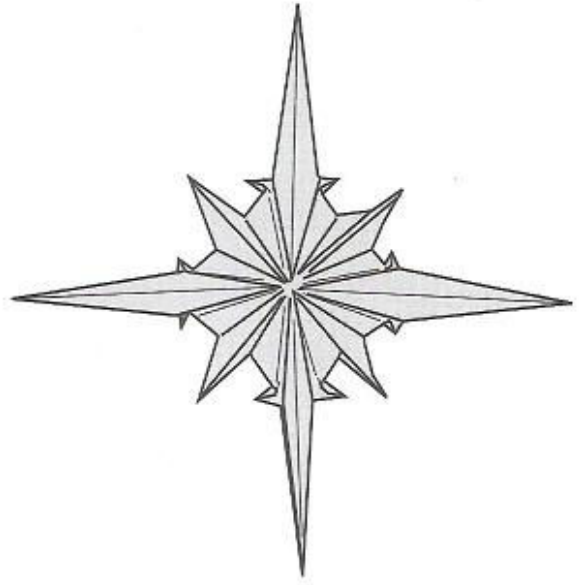

46

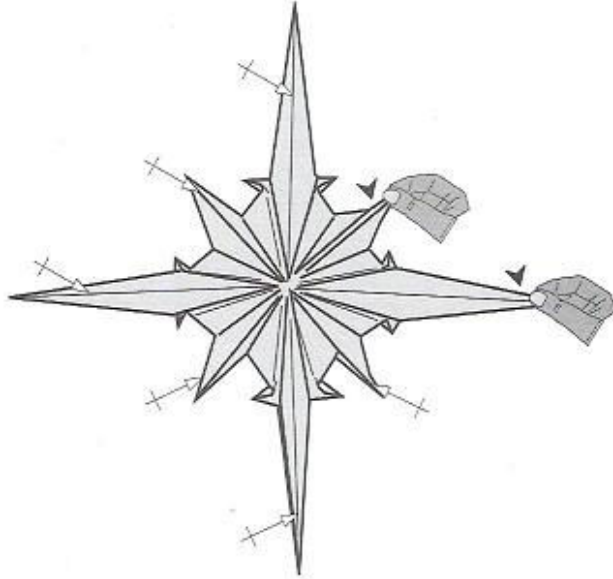

47

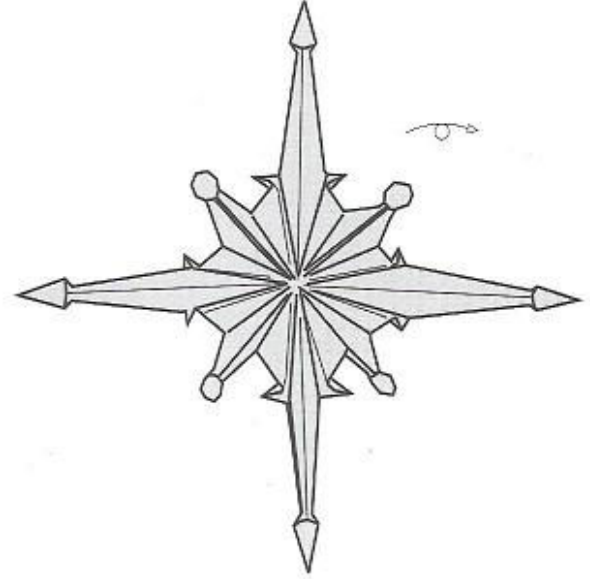

48

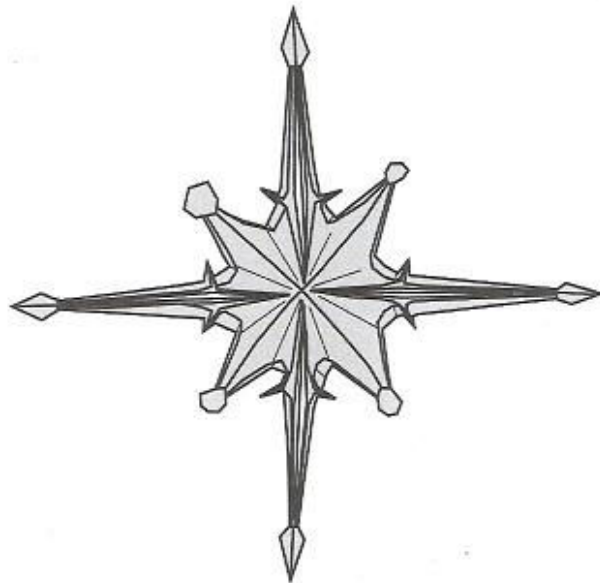

49

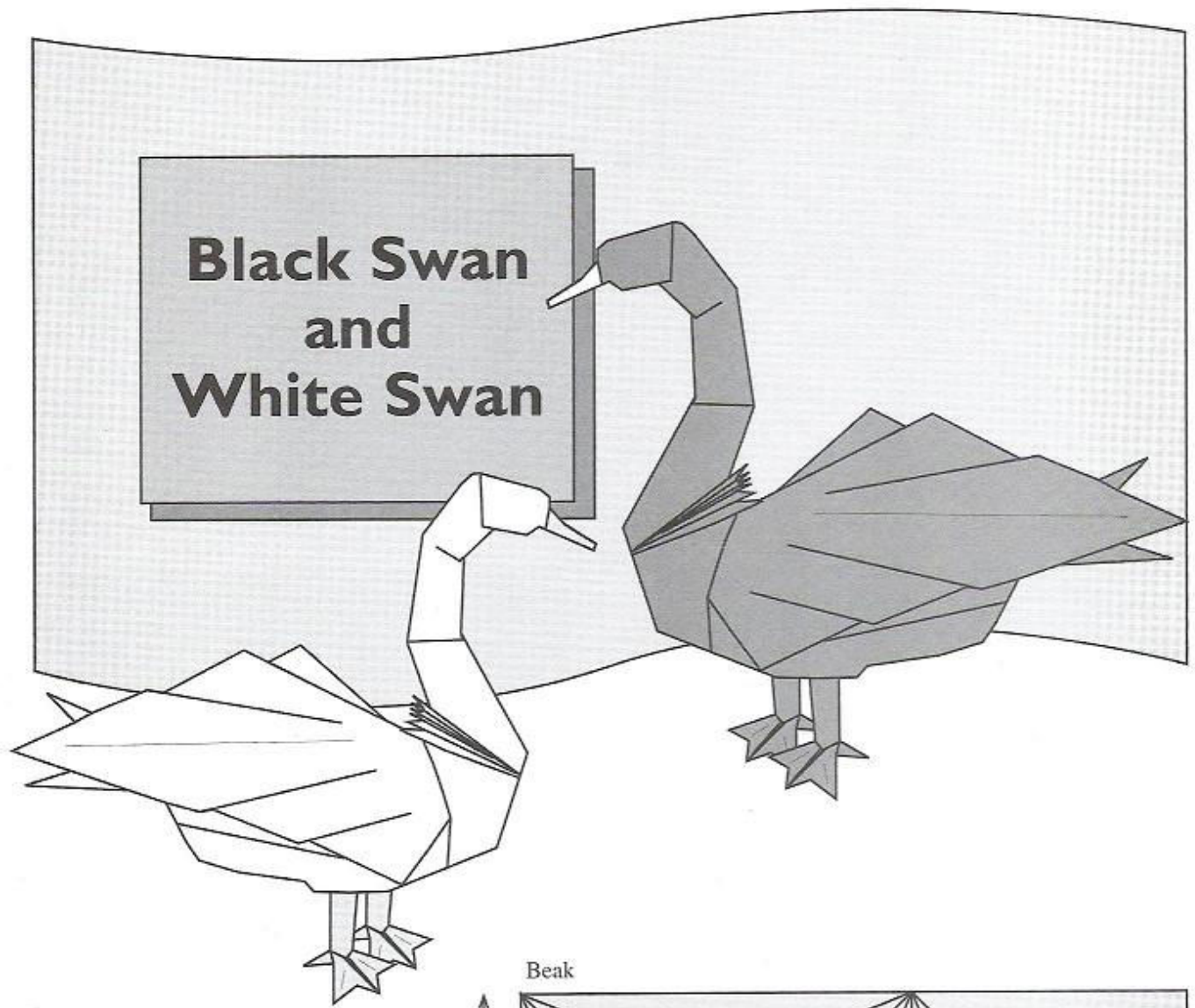

The paper should be white and orange for the white swan. Red and black for the black swan. It should be less than 40 grams, double silk or of the type "sandwich" and 13.75x13.75 inches (35x35 cm) or bigger.

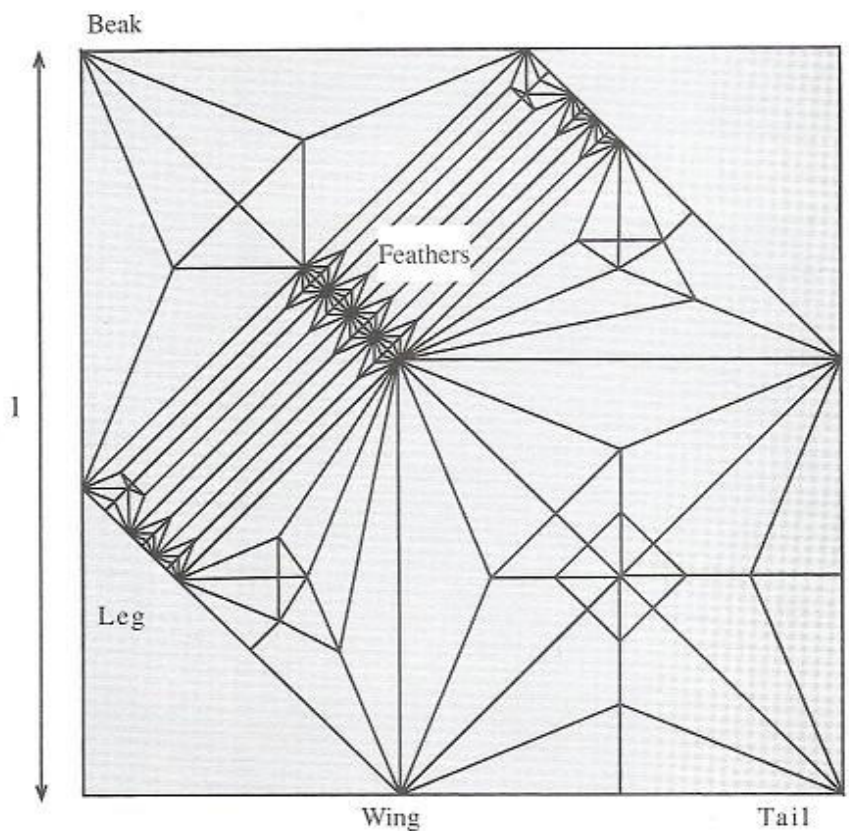
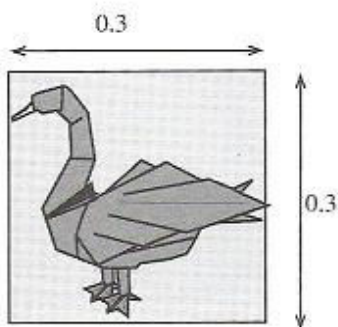

Black Swan

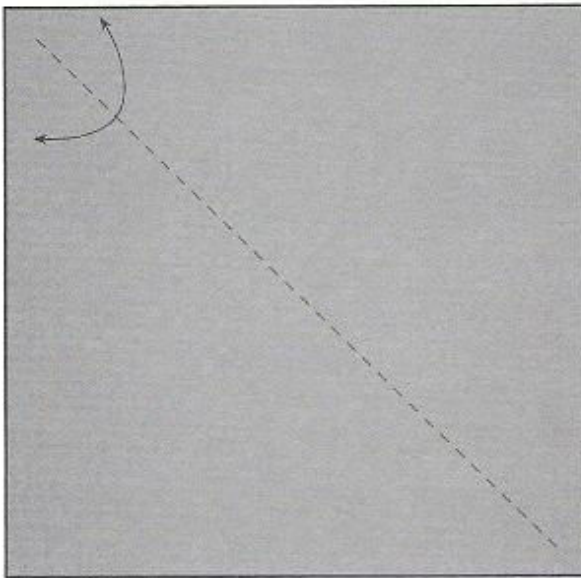

1  black
red

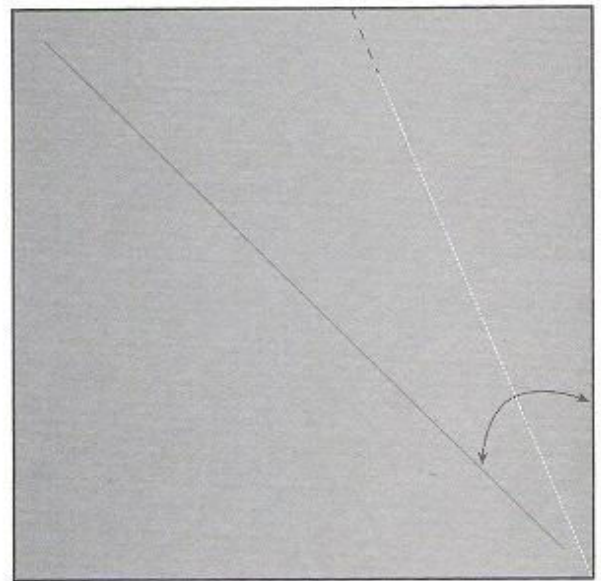

2

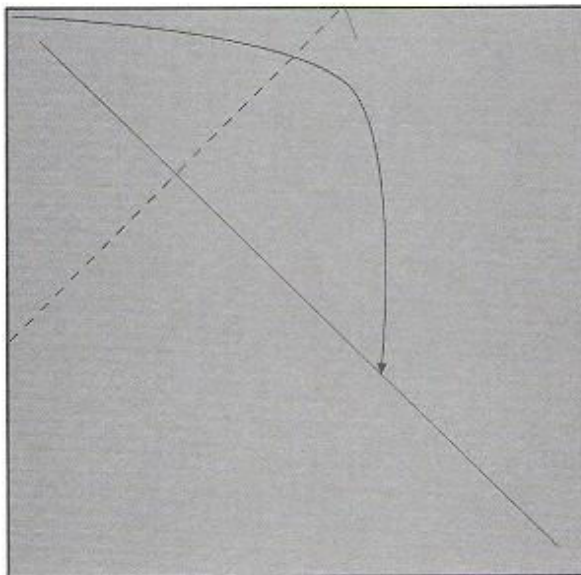

3

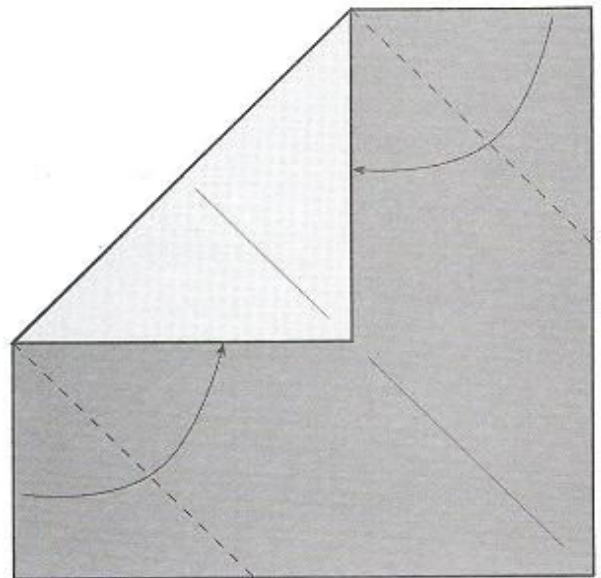

4

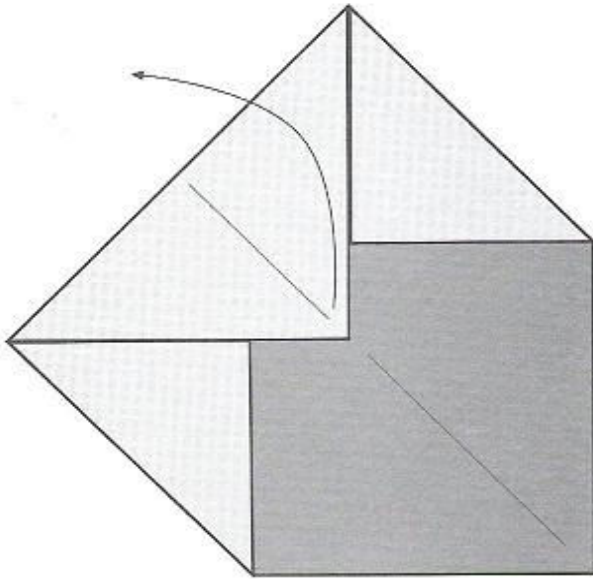

5

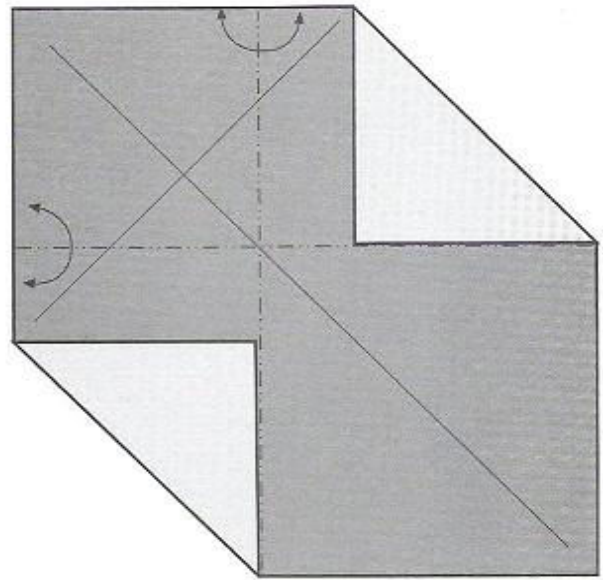

6

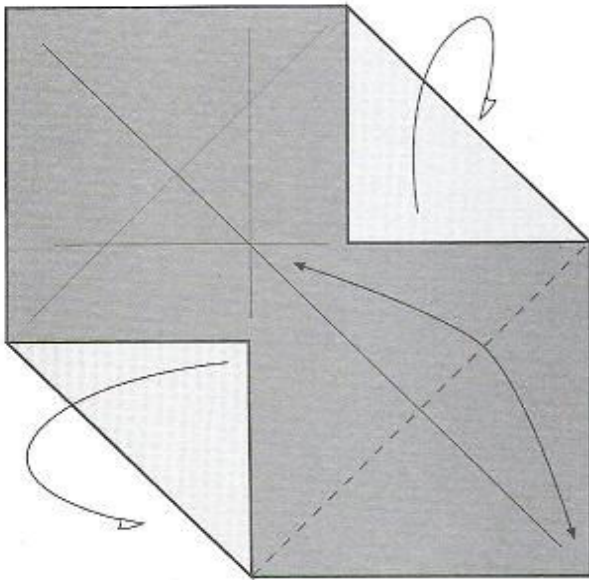

7

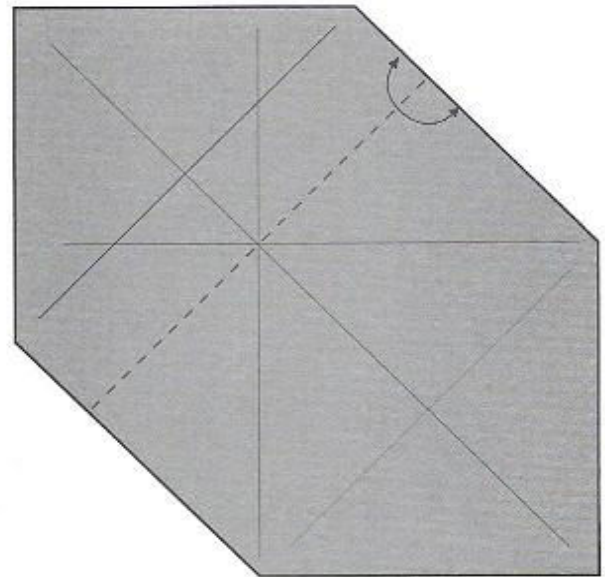

8

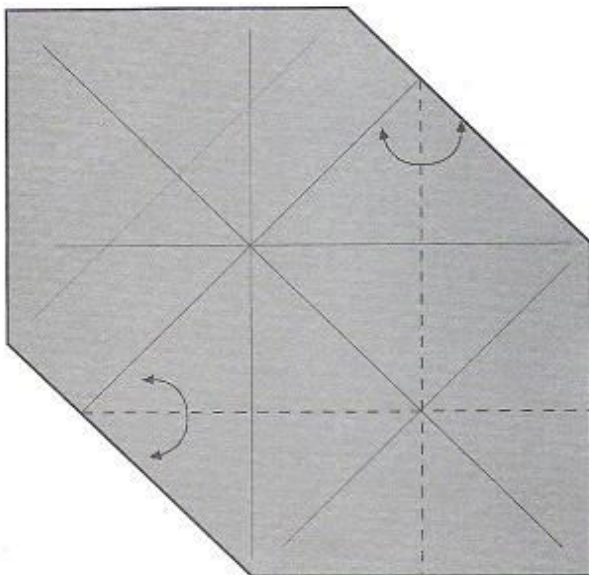

9

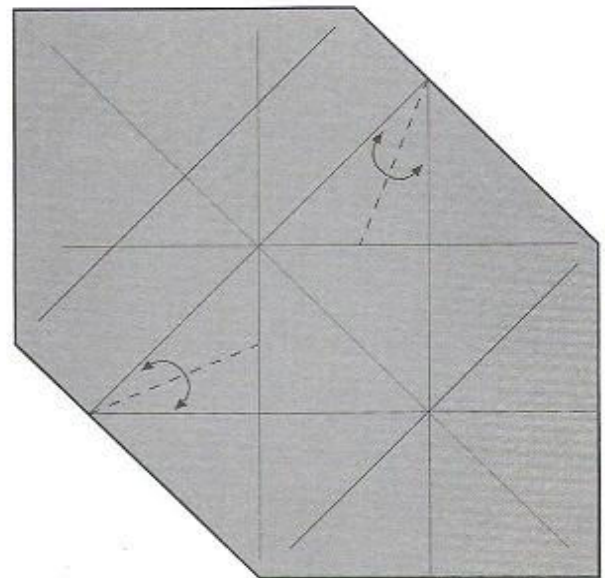

10

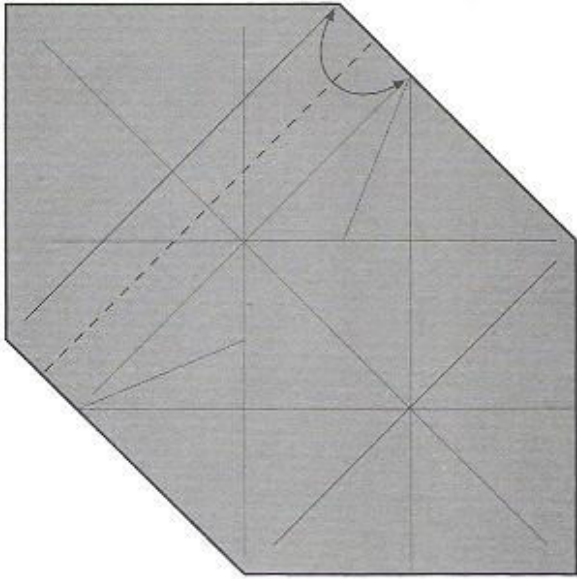

11

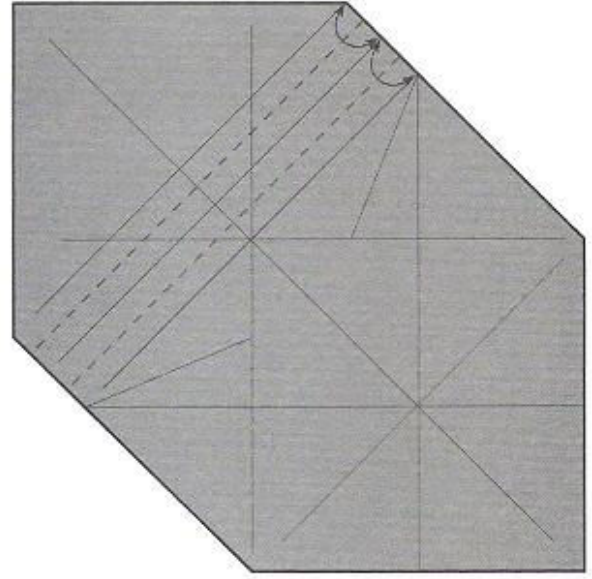

12

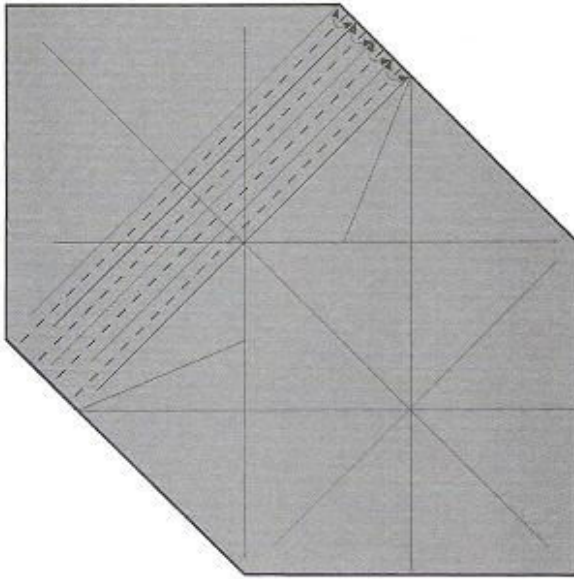

13

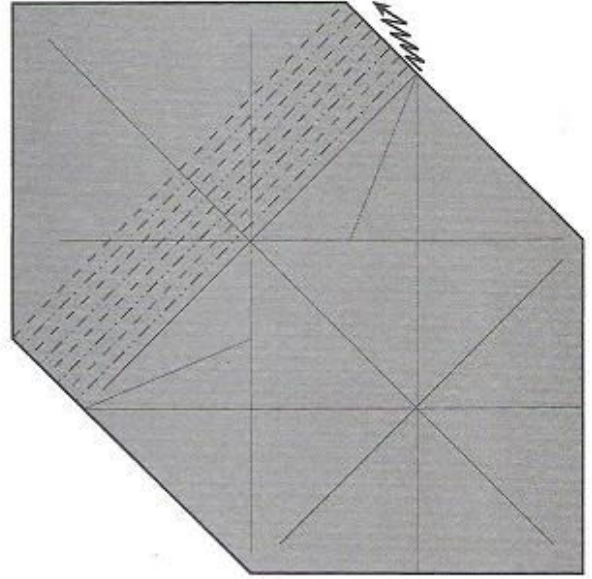

14

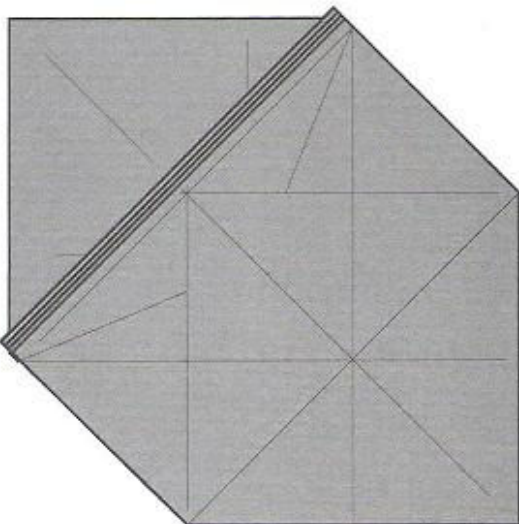

15 In process

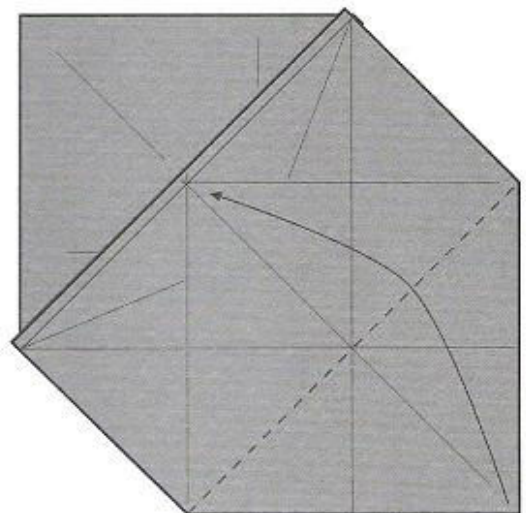

16

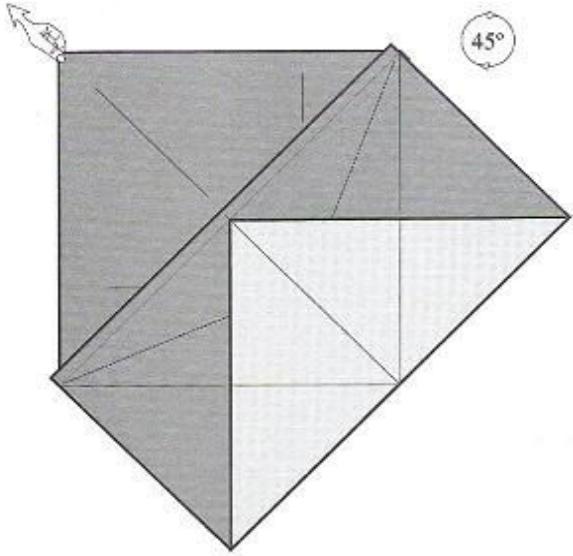

17

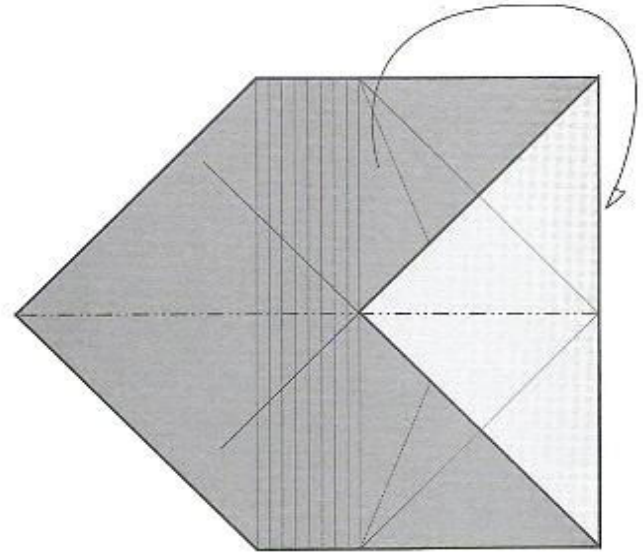

18

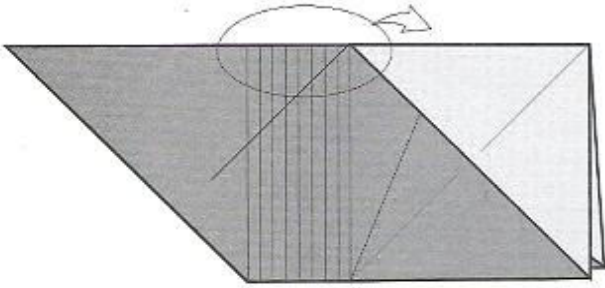

19

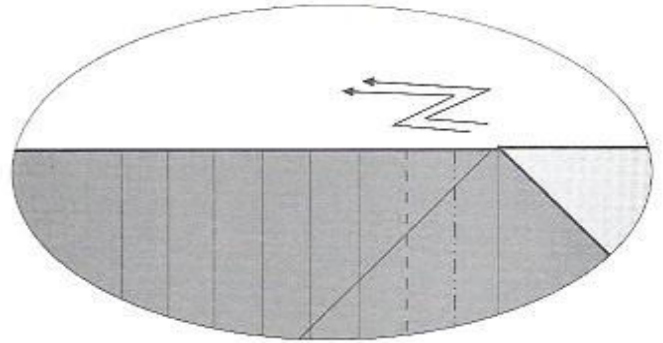

20

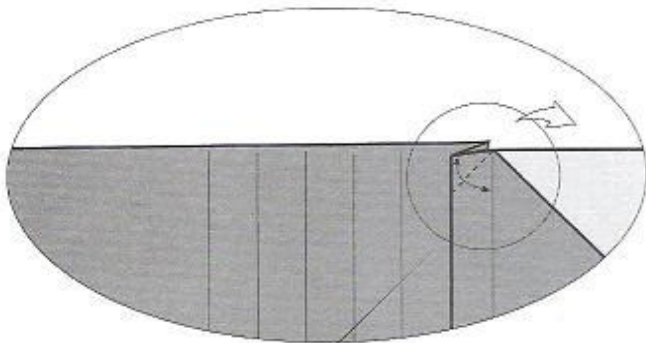

21

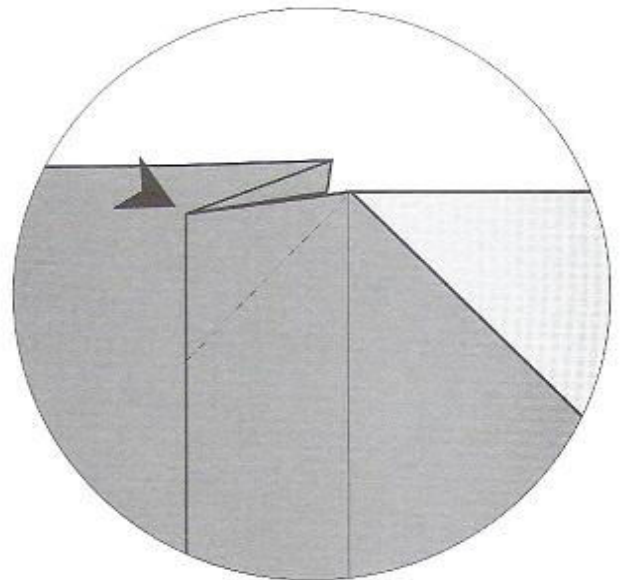

22

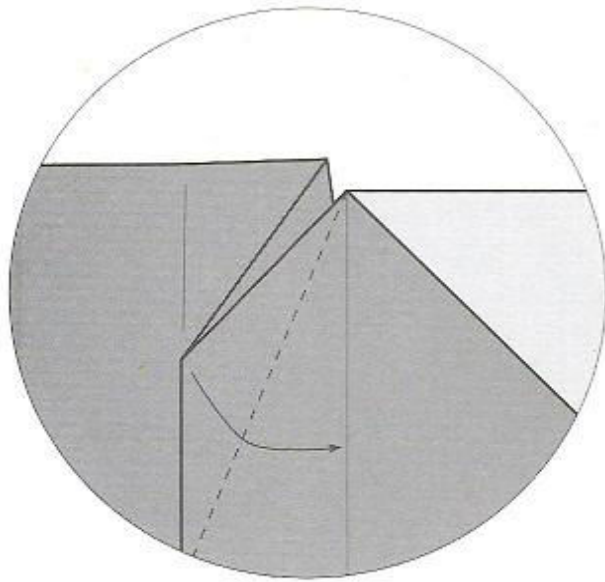

23

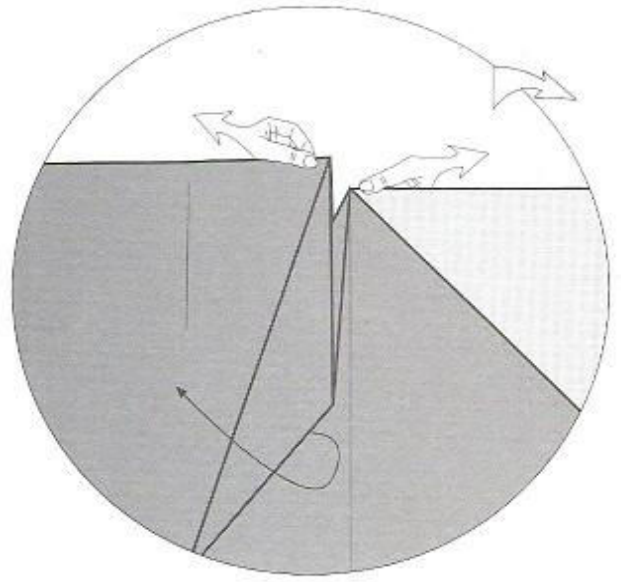

24

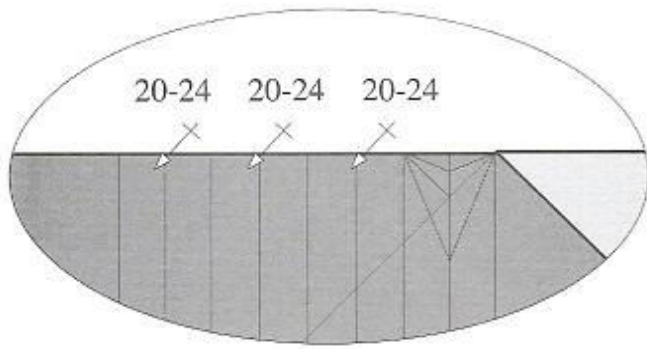

25

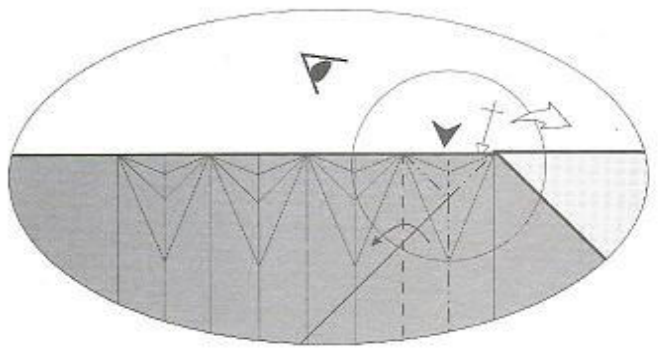

26

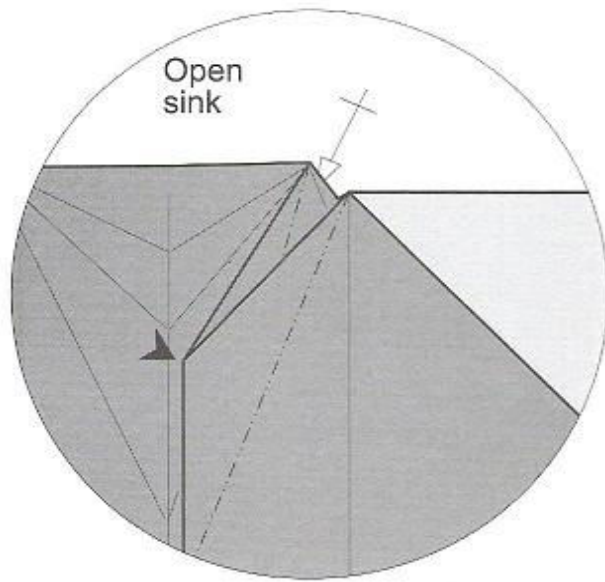

27

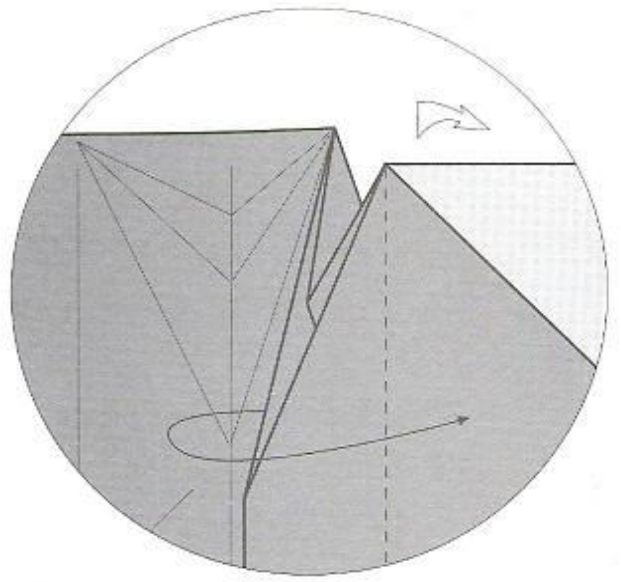

28

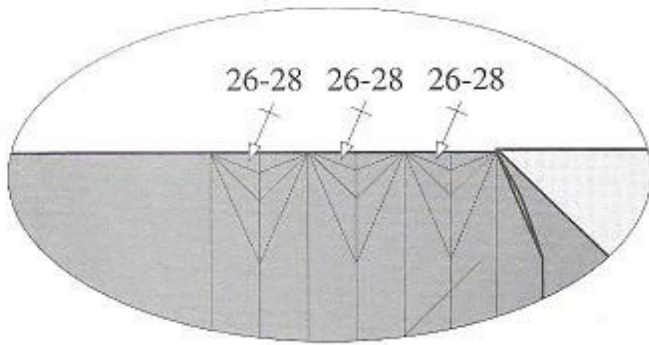

29

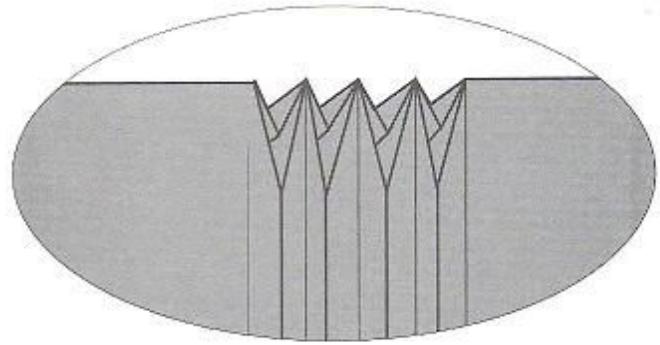

30

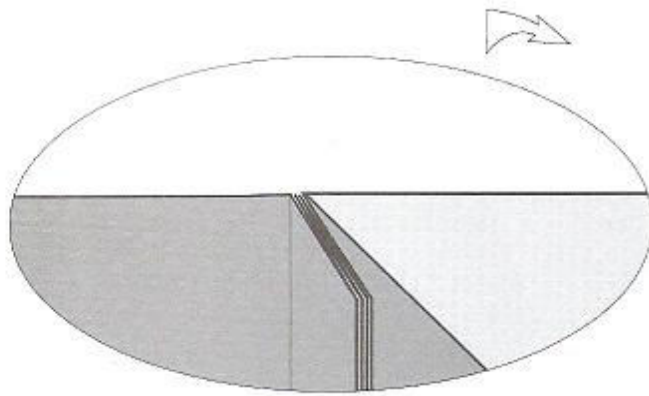

31

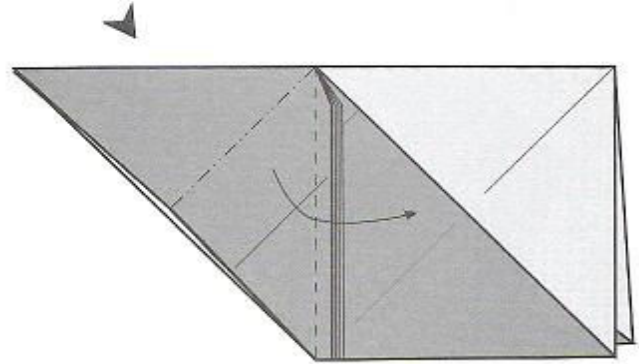

32

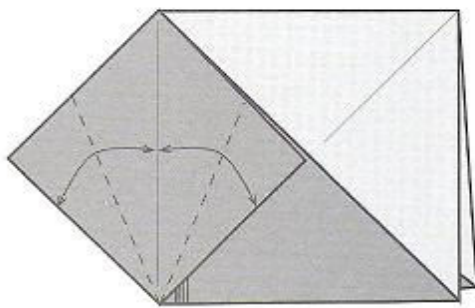

33

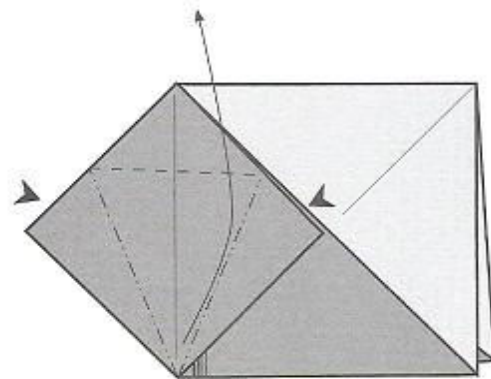

34

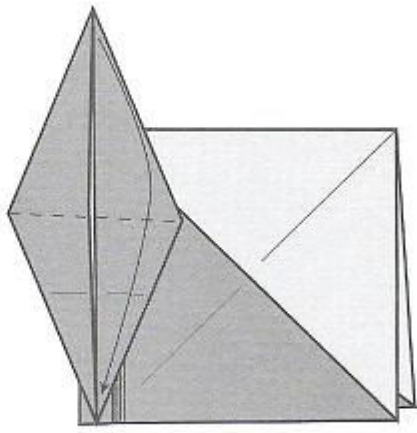

35

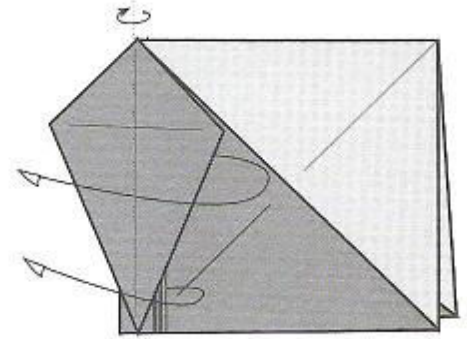

36

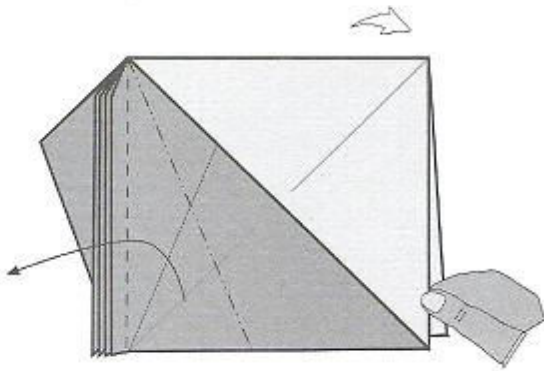

37

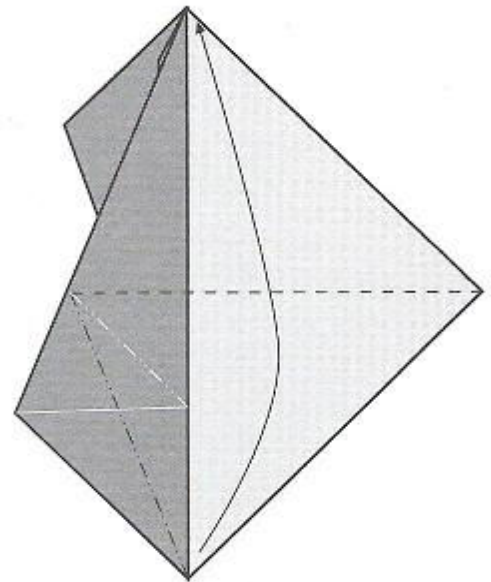

38

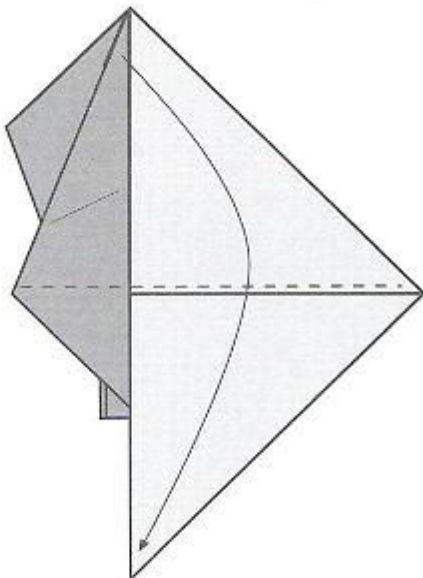

39

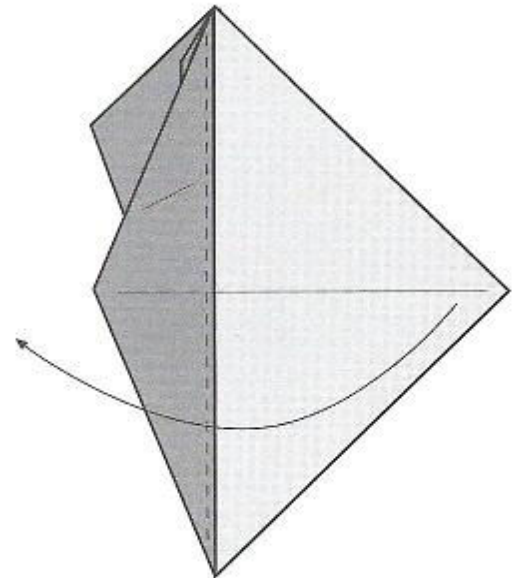

40

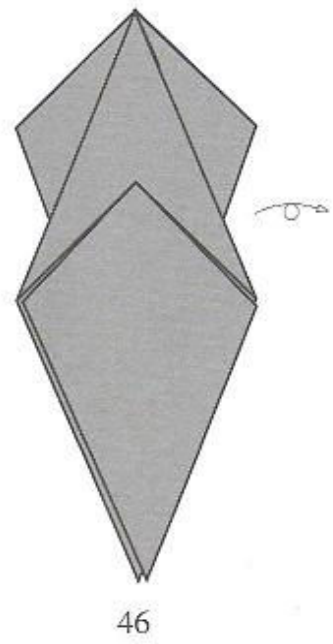
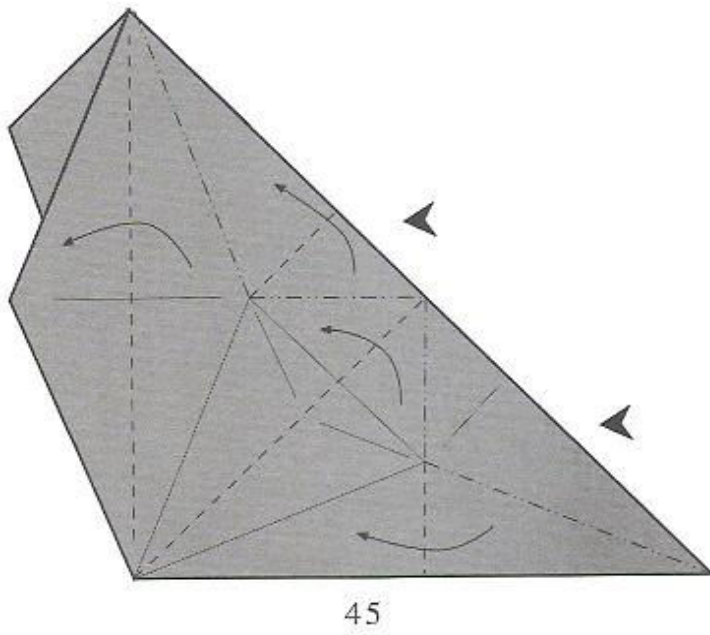
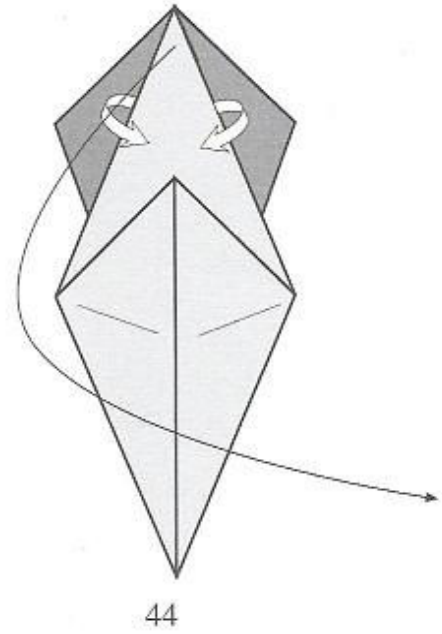
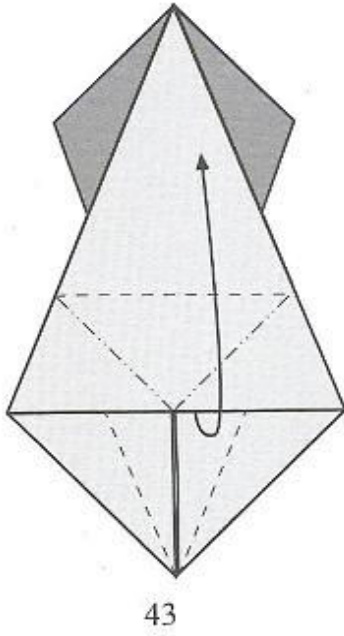
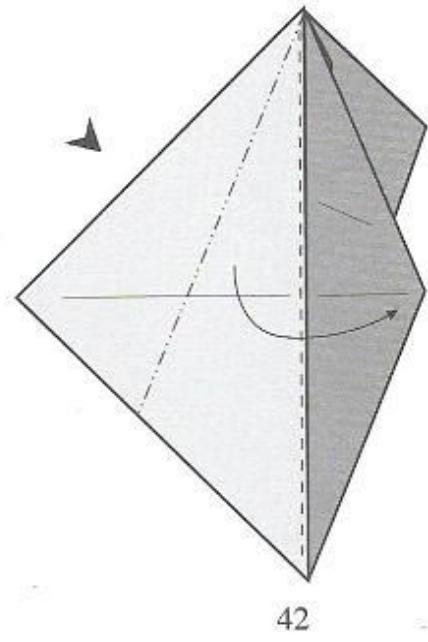
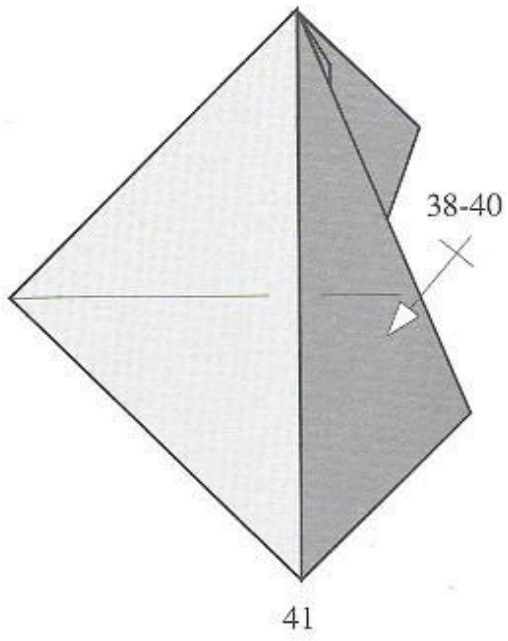

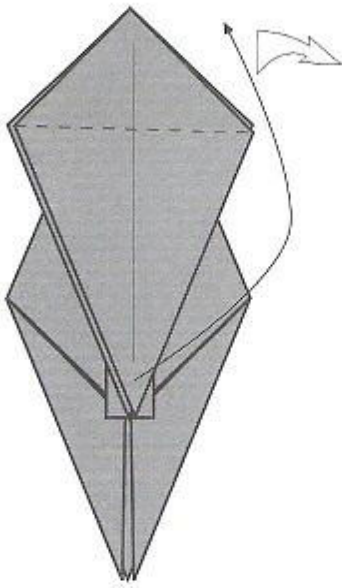

47



48

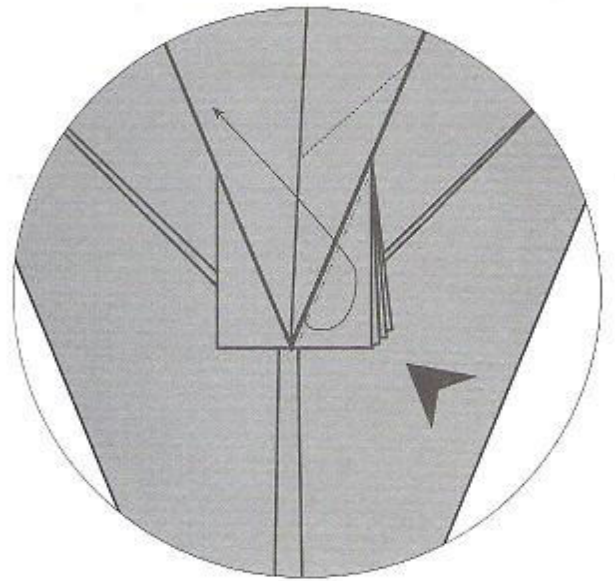

49

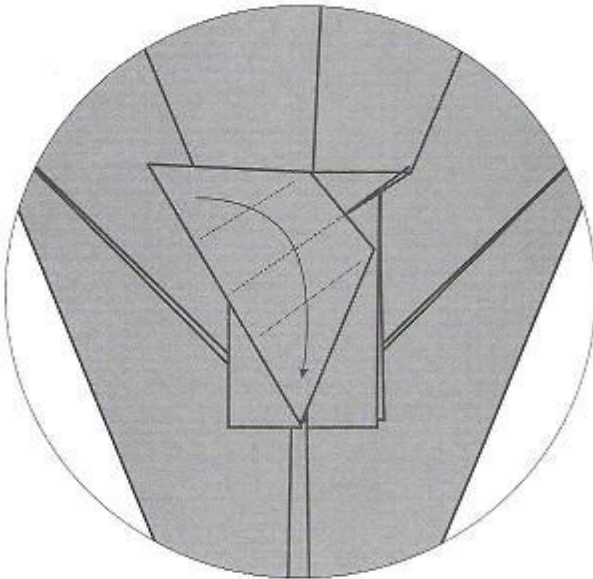

50

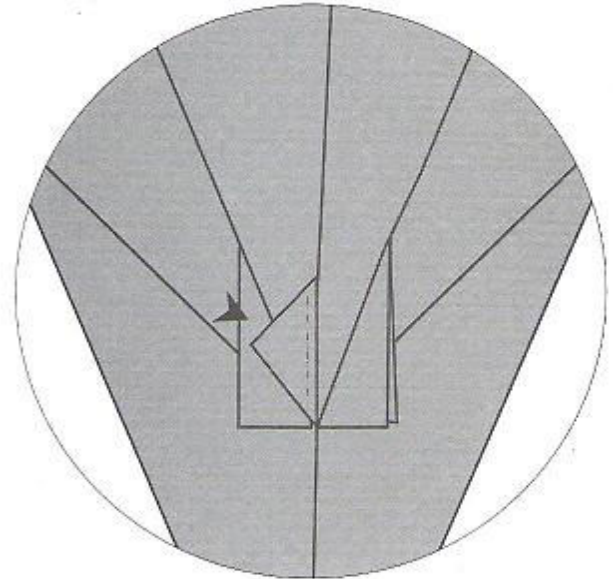

51

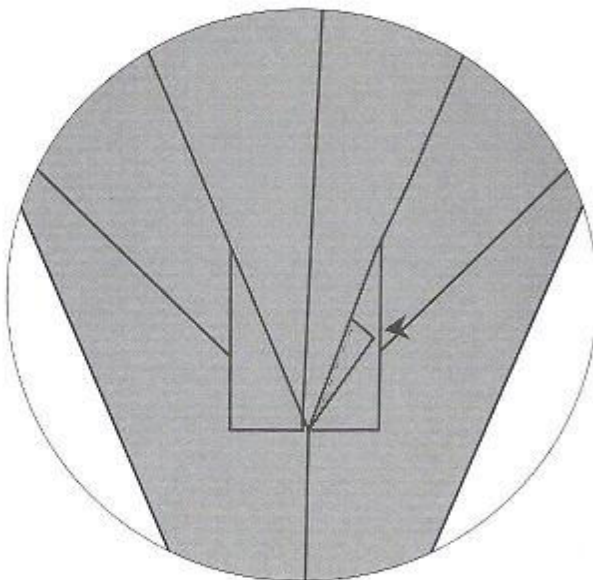

52

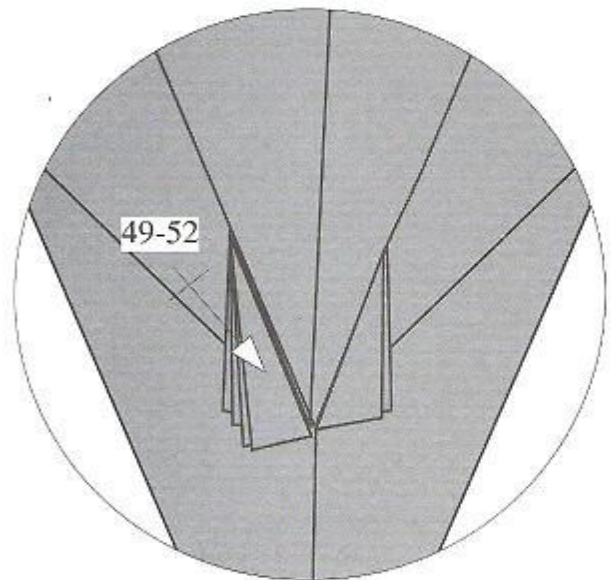

53

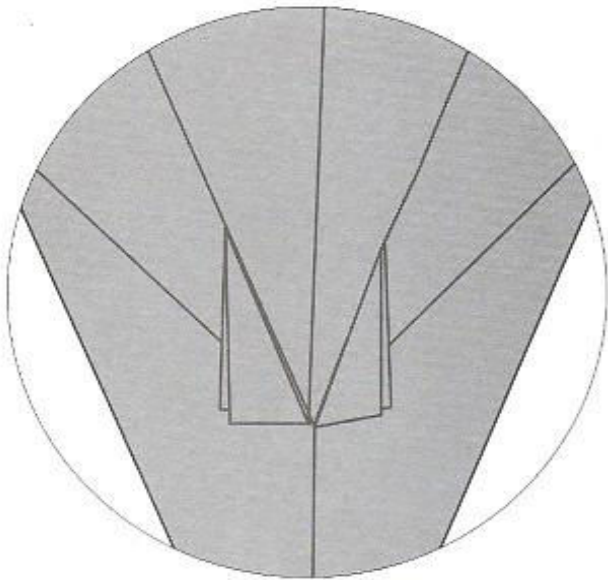

54

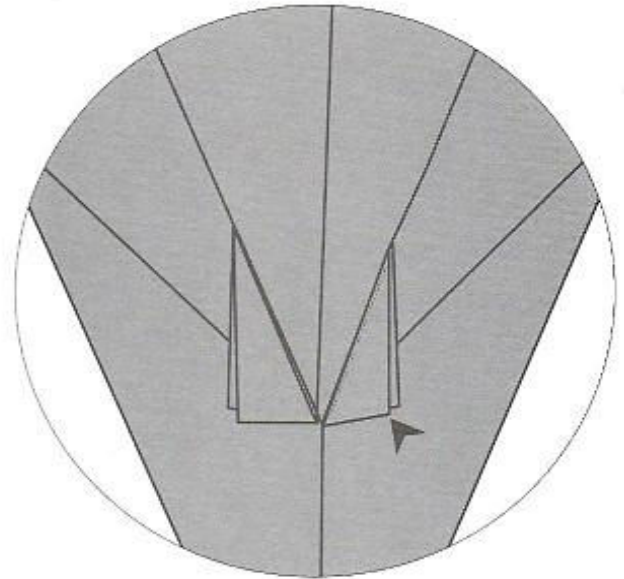

55

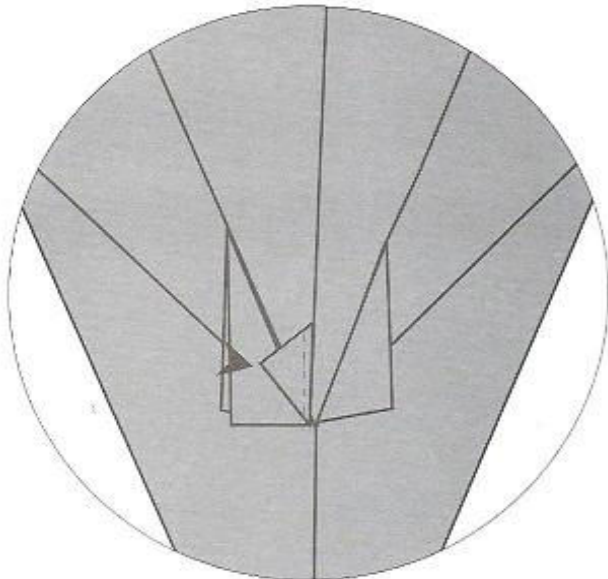

56

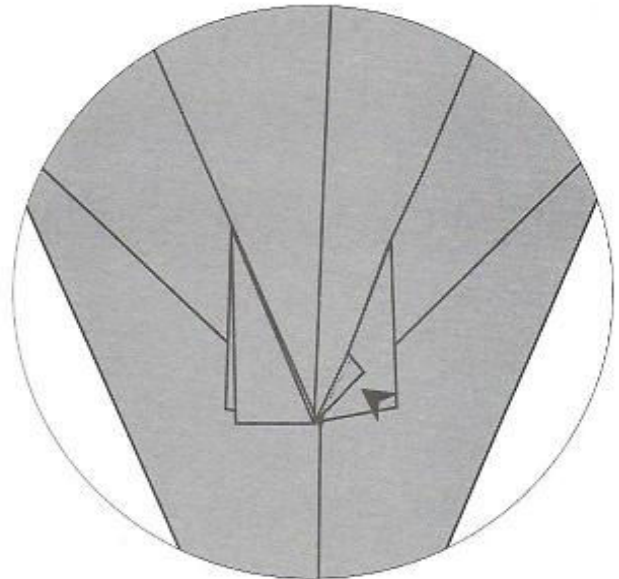

57

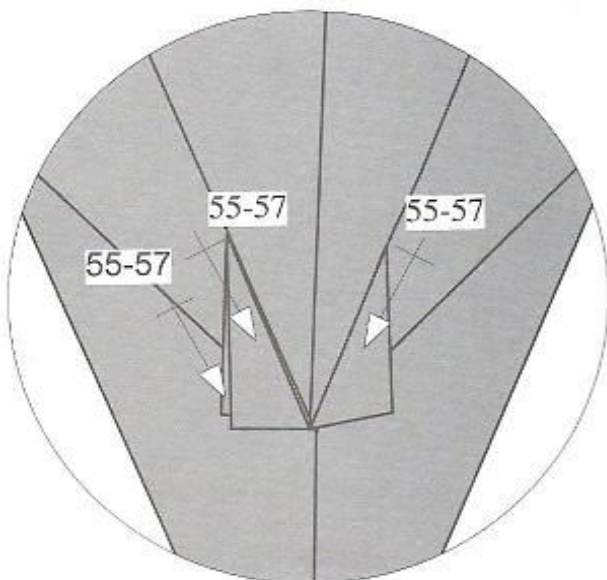

58

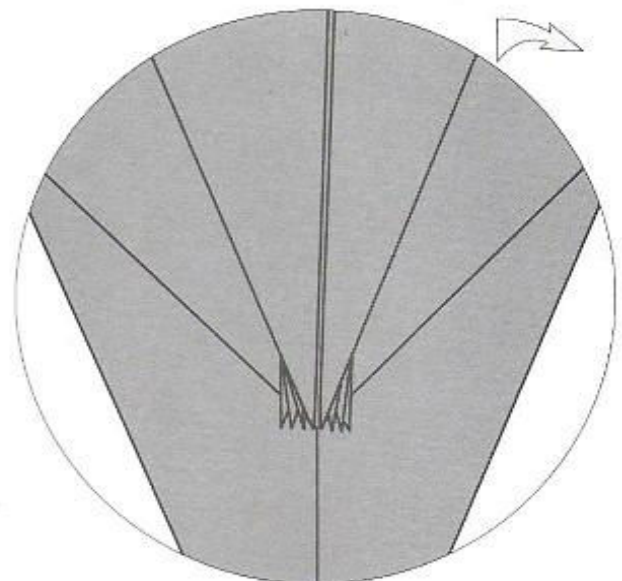

59



60

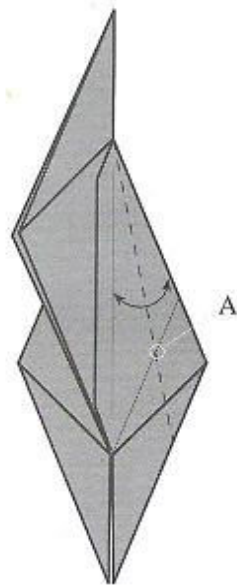

61

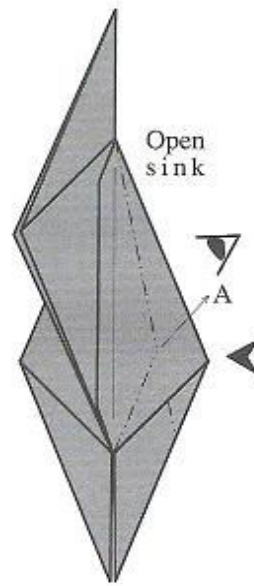

62

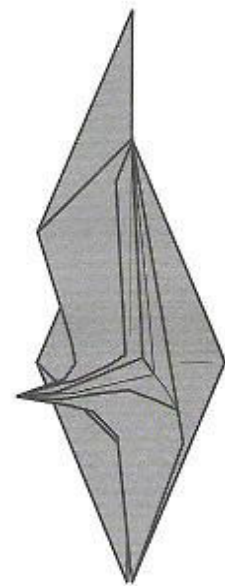

63

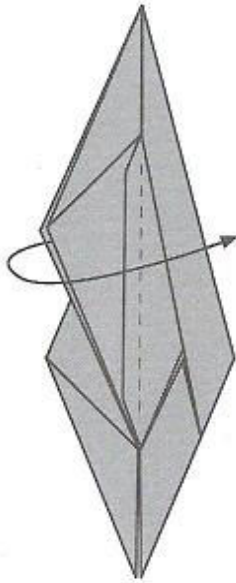

64

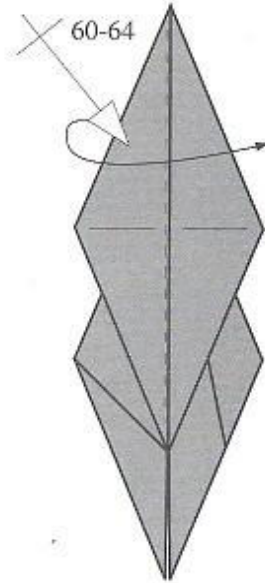

65

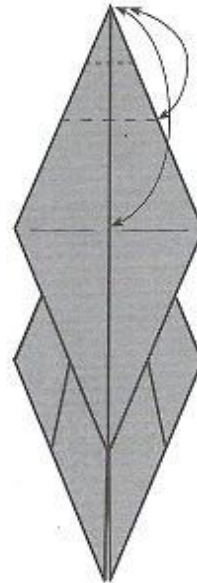

66

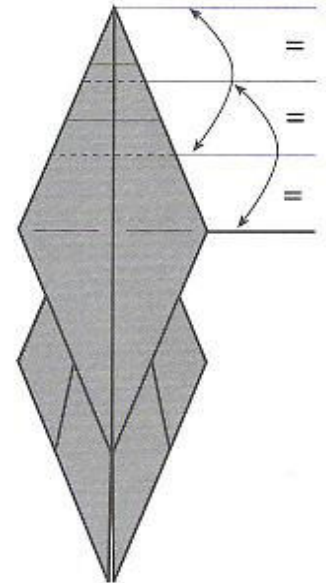

67

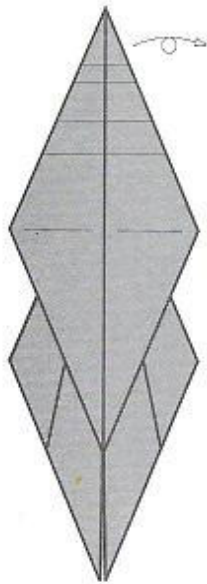

68

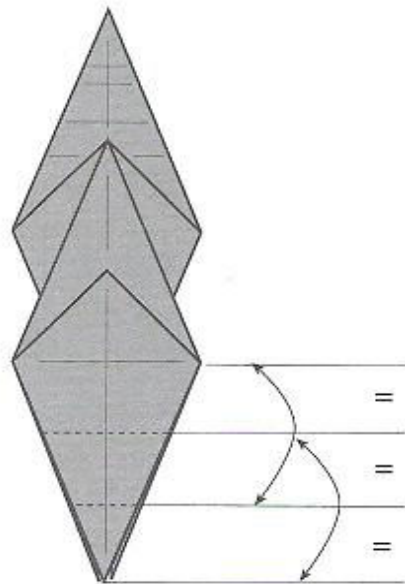

69



70

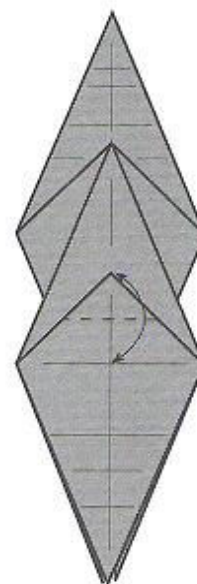

71



72



73-3D



74

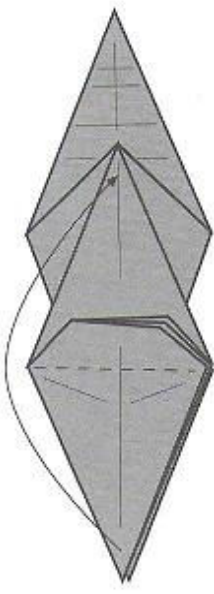

75

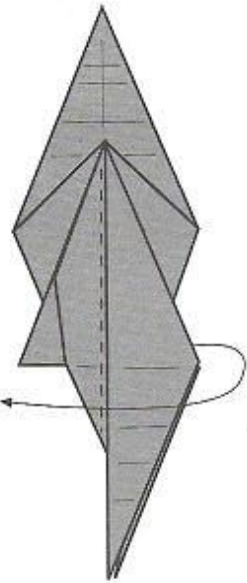

76

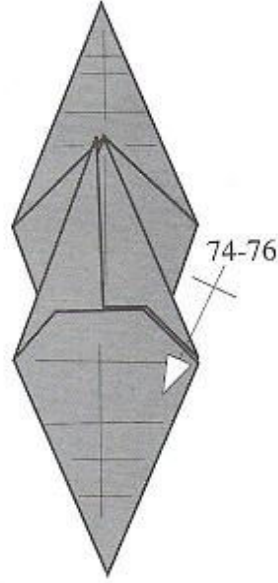

77

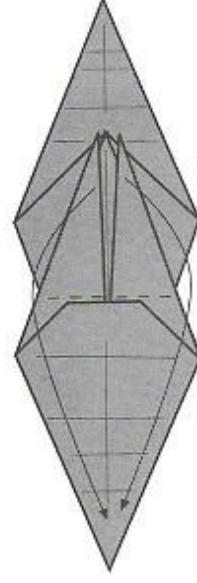

78



79

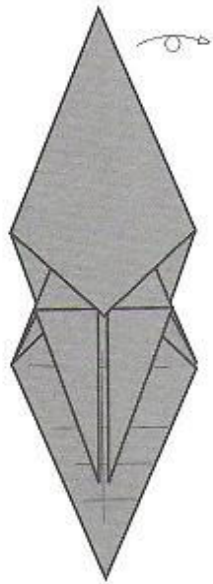

80

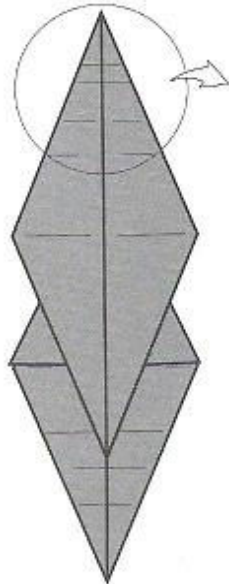

81

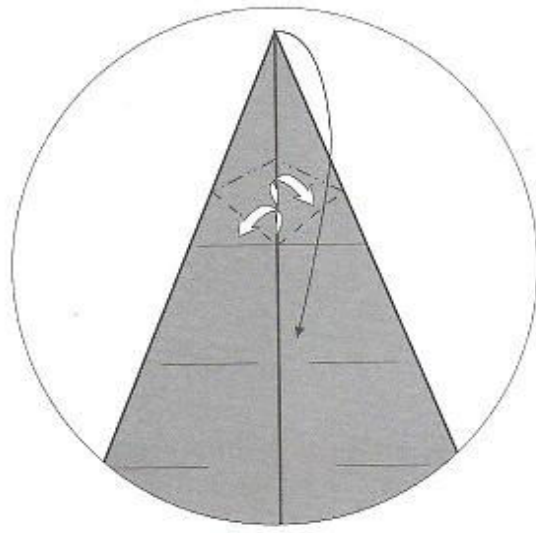

82

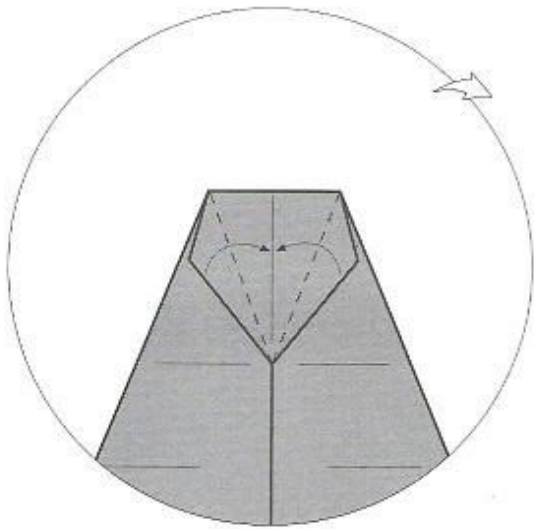

83

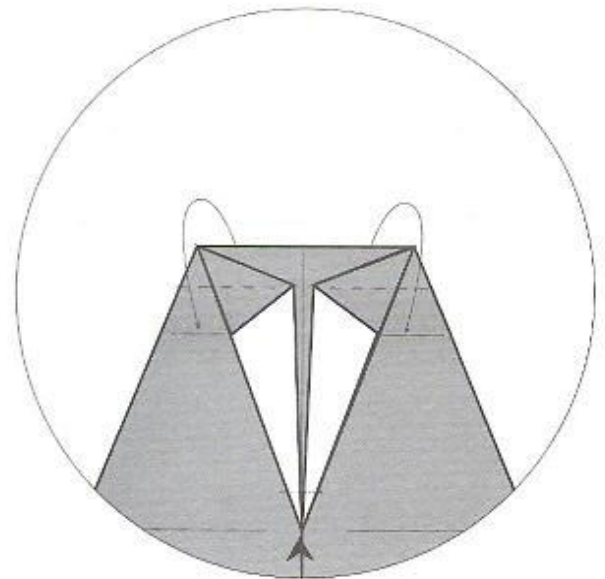

84

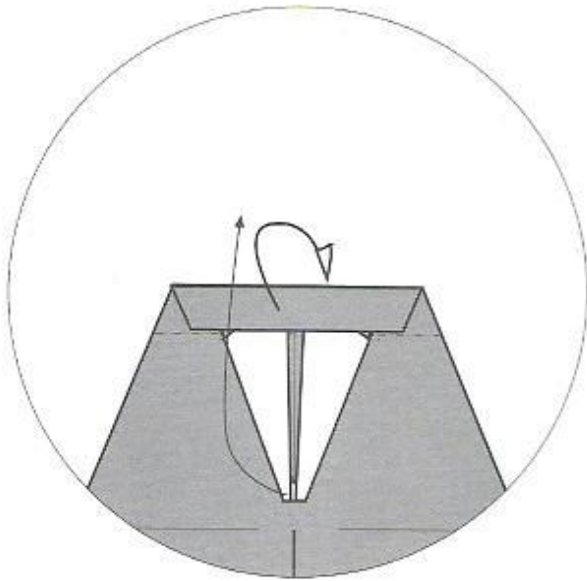

85

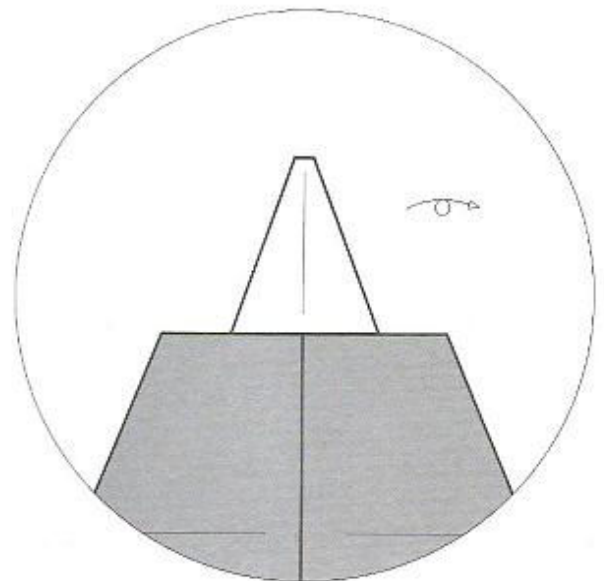

86

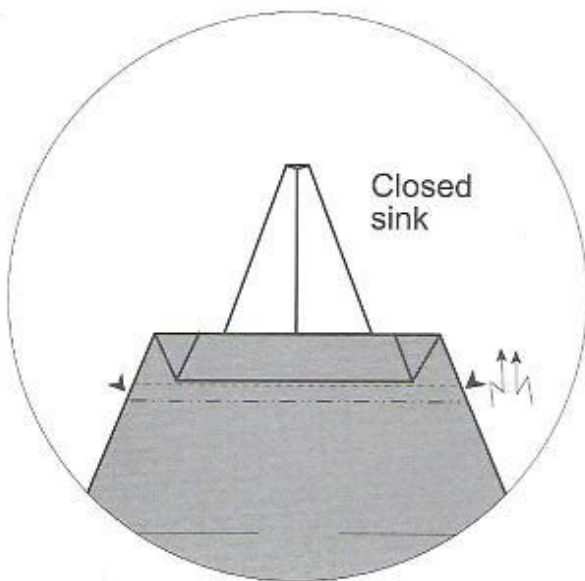

87

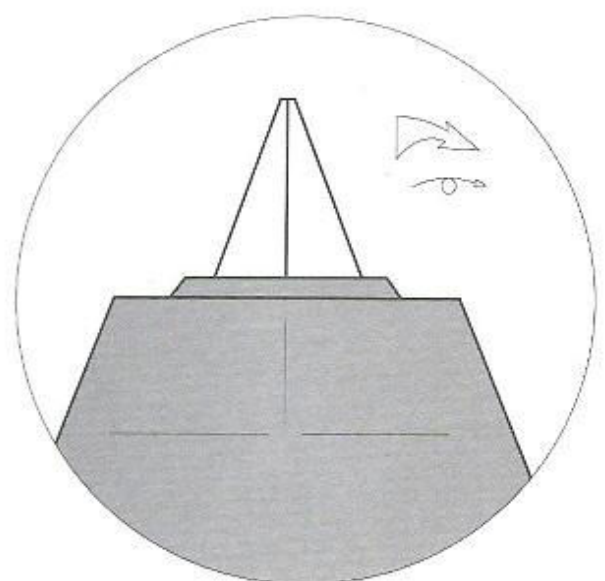

88

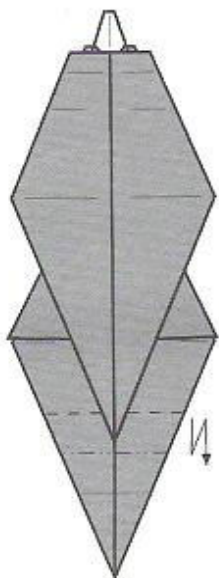

89

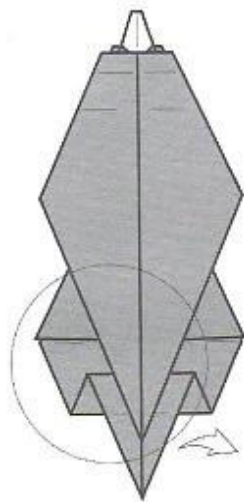

90

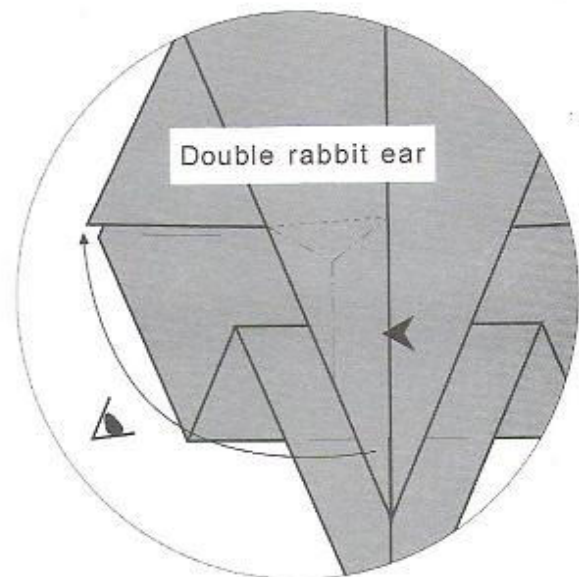

91

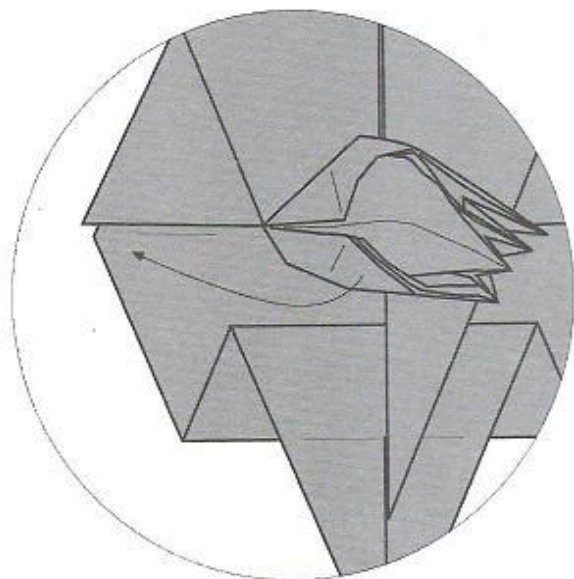

92

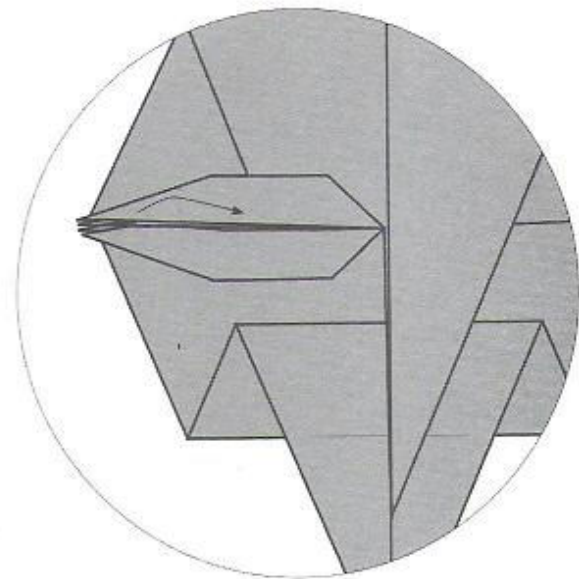

93

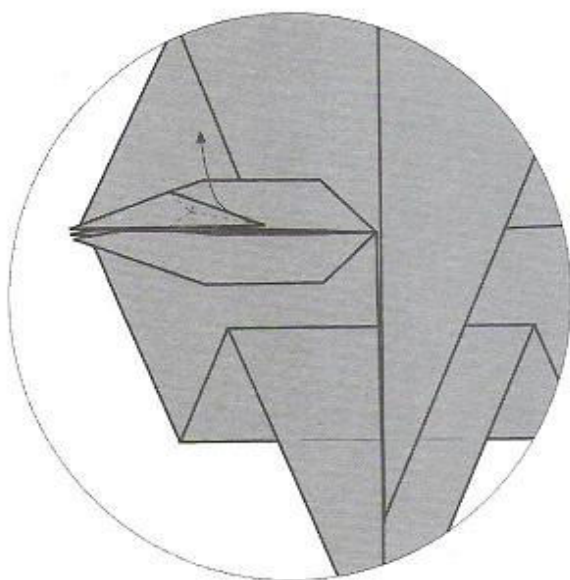

94

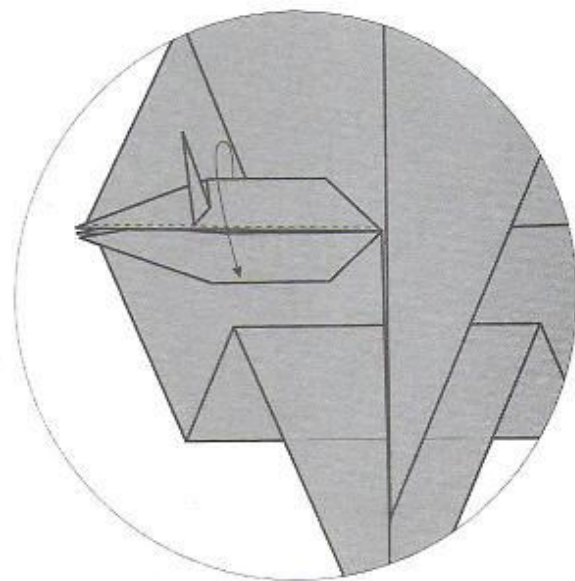

95

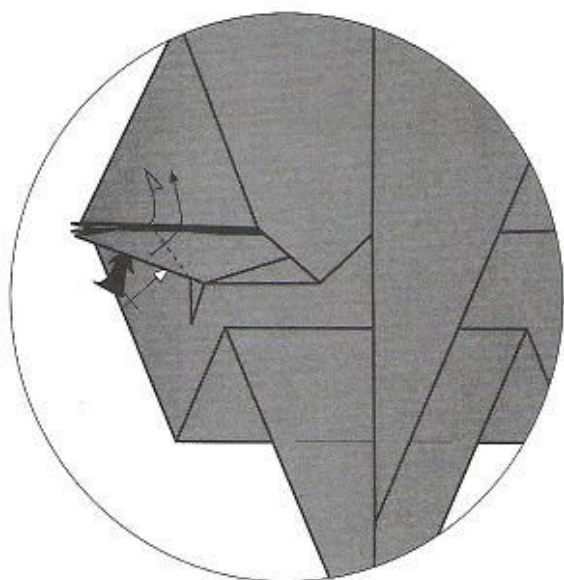

96

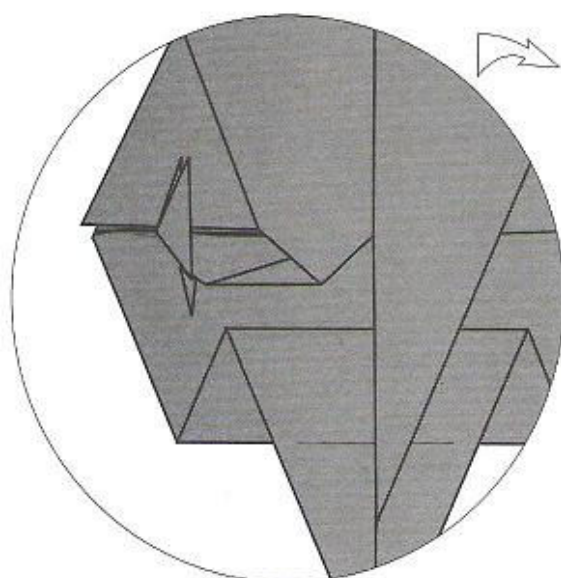

97

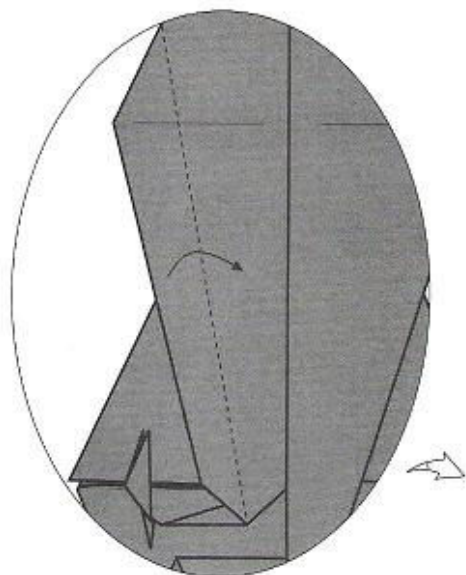

98

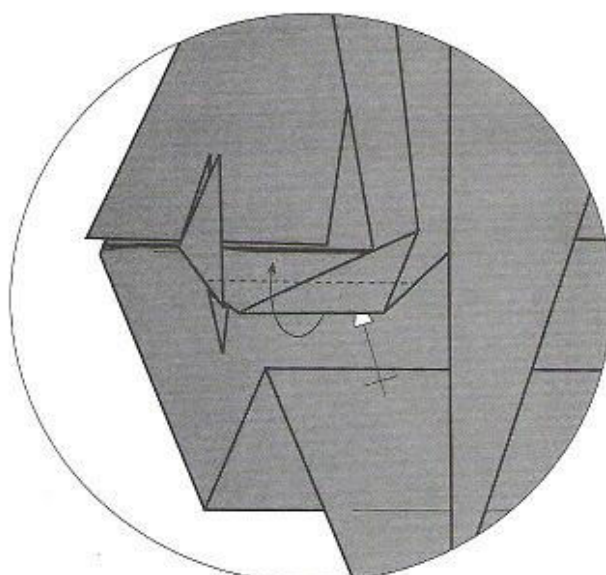

99

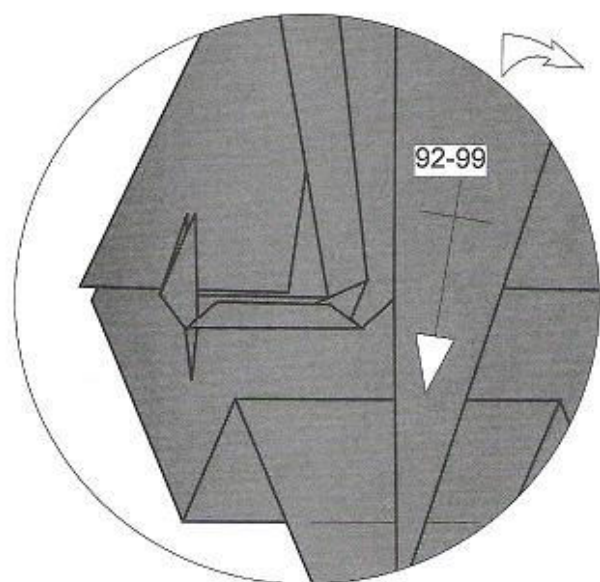

100

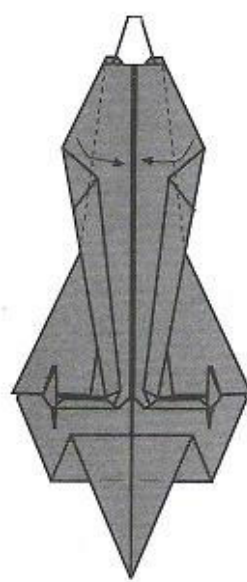

101

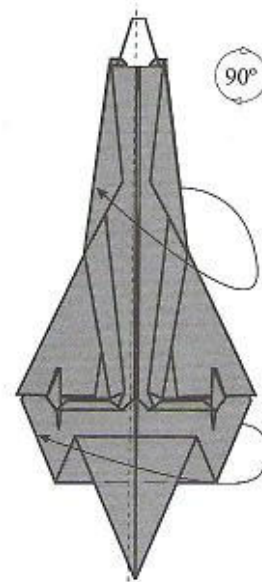

102

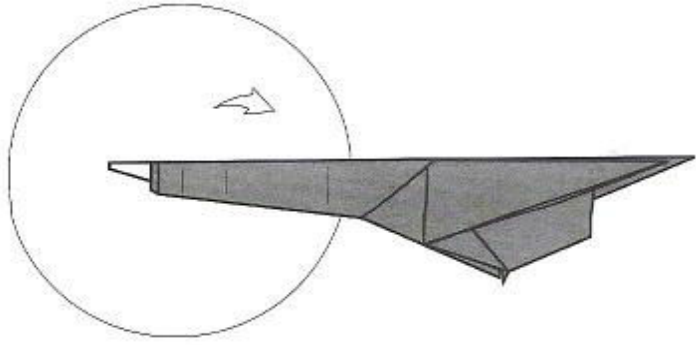

103

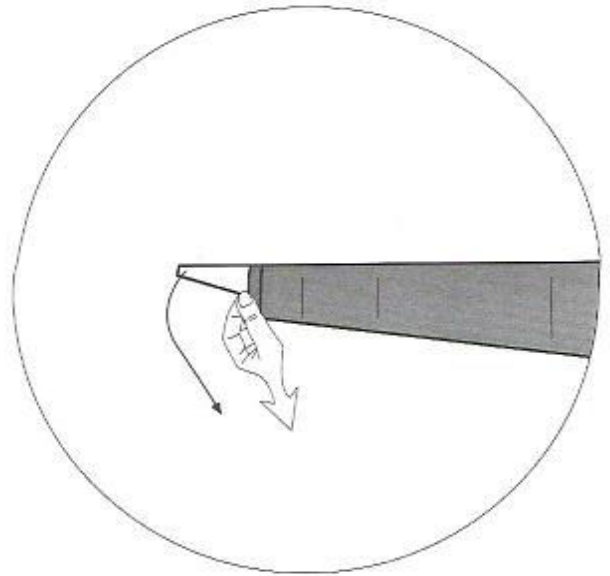

104

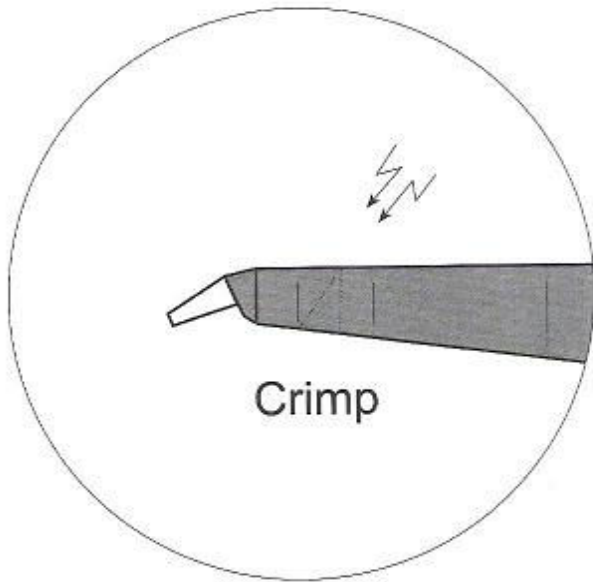

Crimp

105

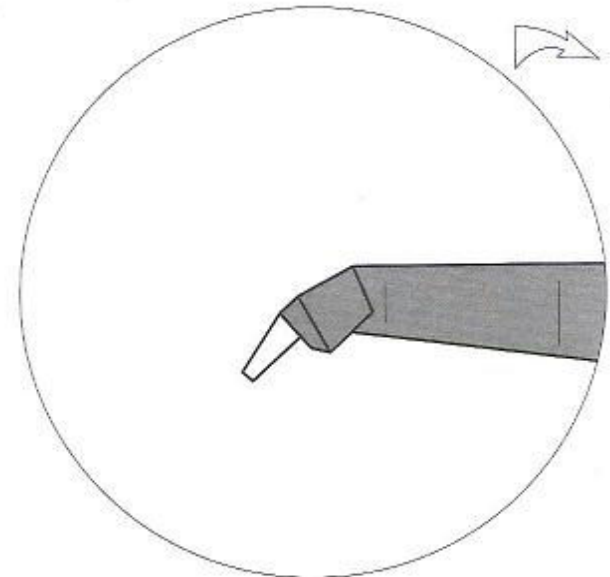

106

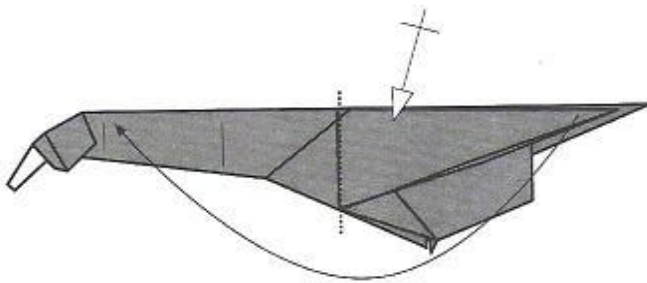

107



108

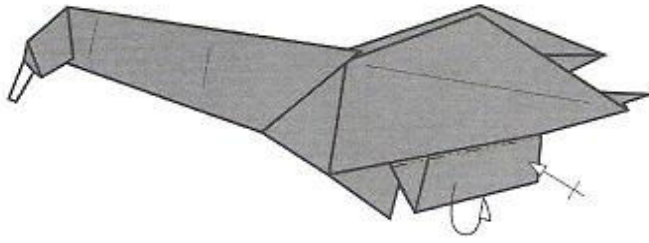

109

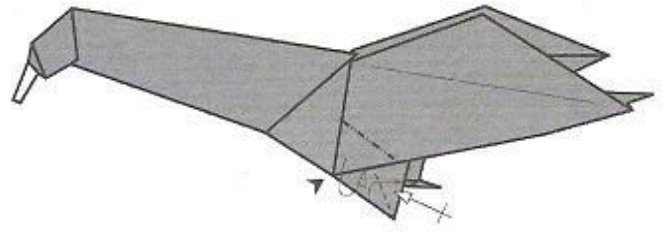

110

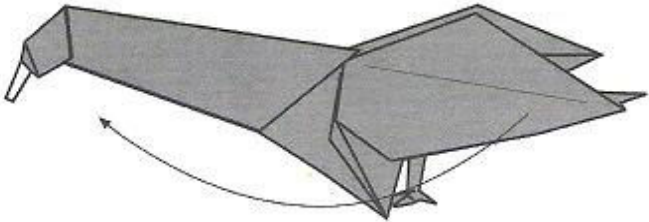

111

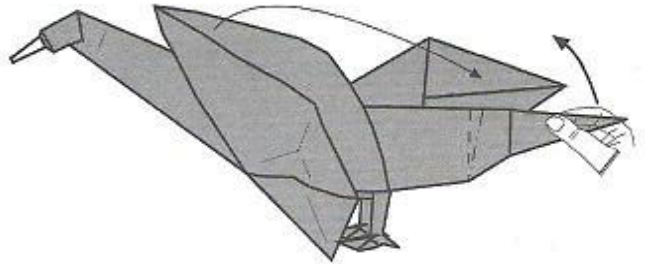

112

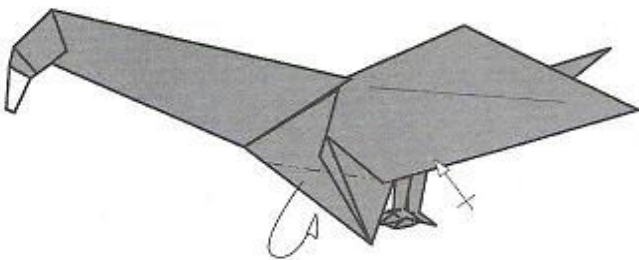

113

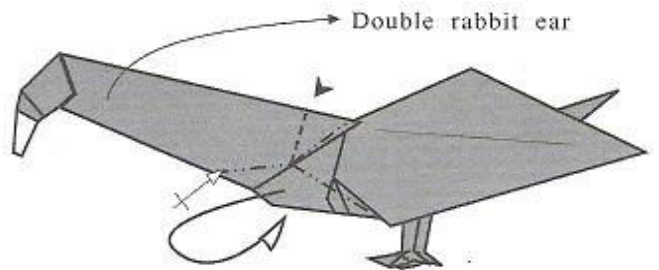

114

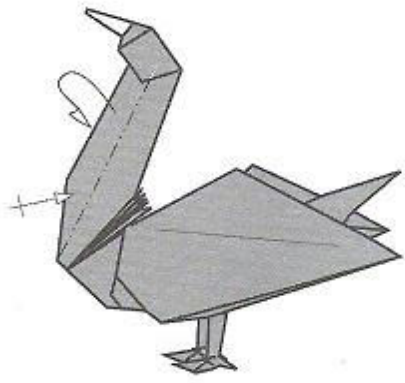

115

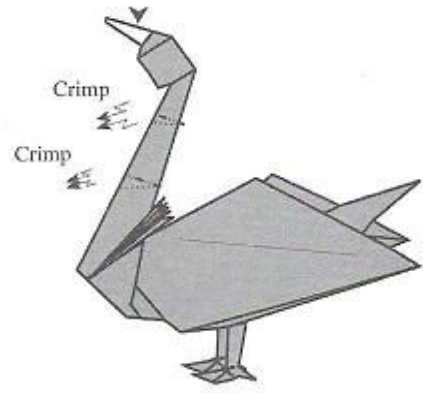

116

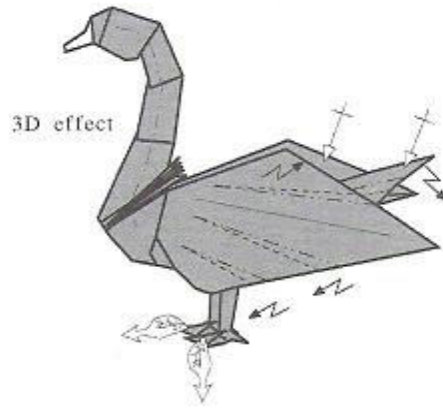

117

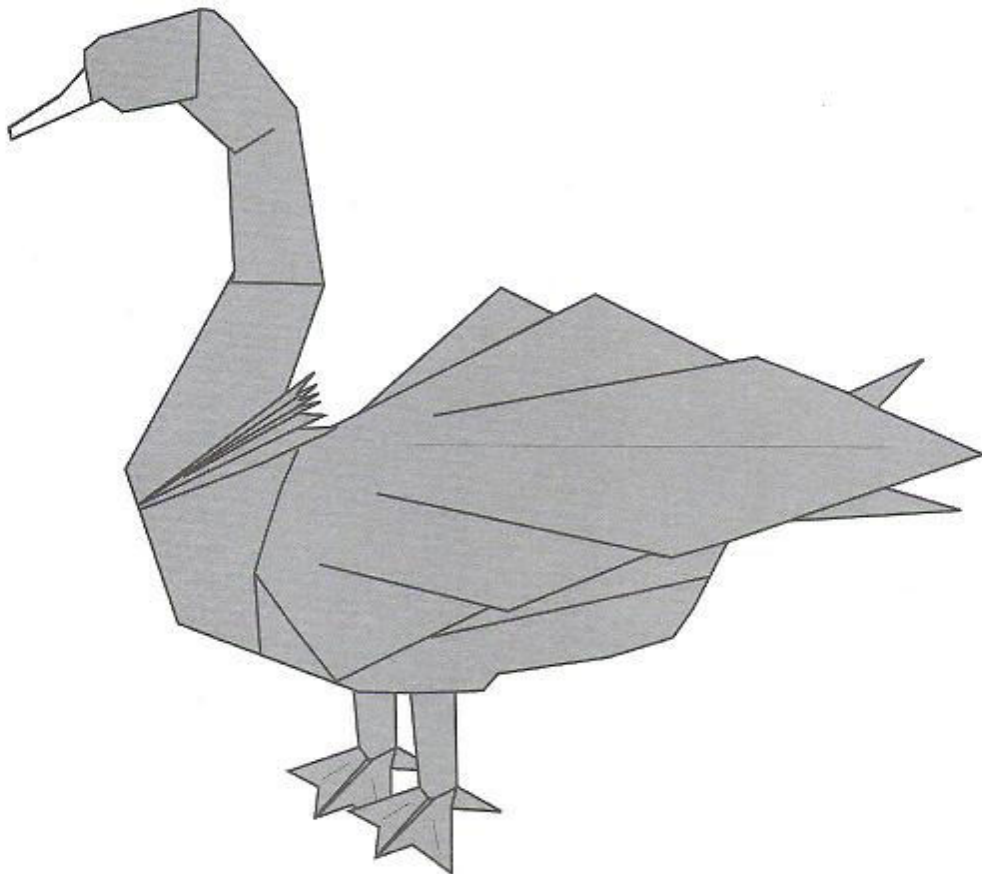

118

117

White Swan

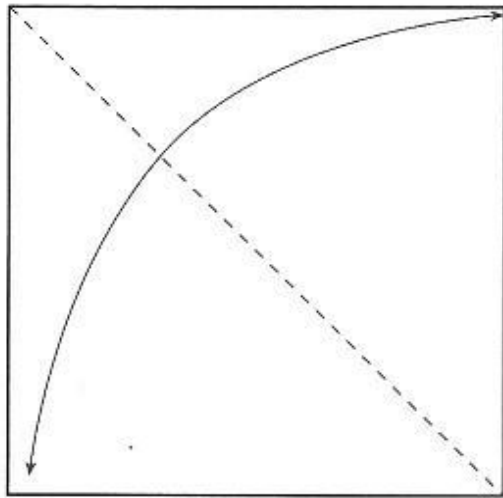

1 ⊕ White
Orange

Steps 1-6 Black swan

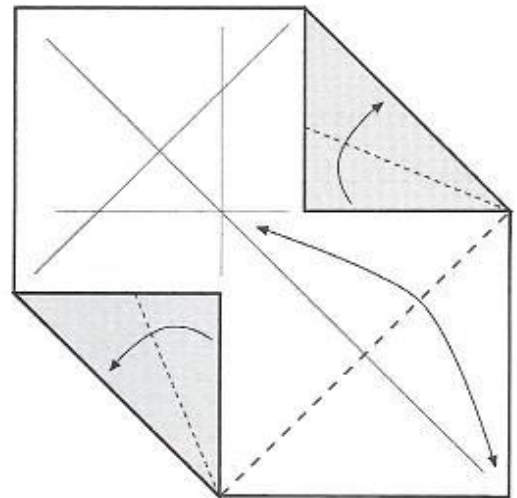

7-A

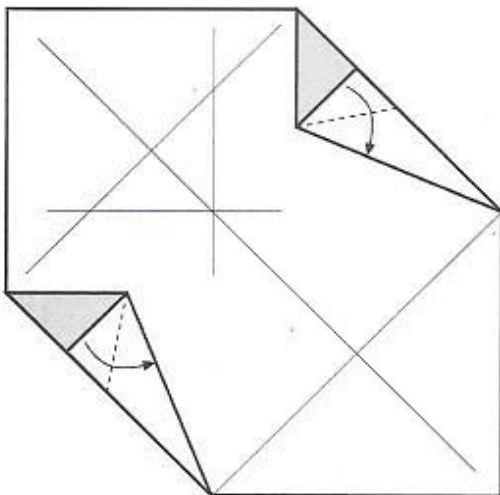

7-B

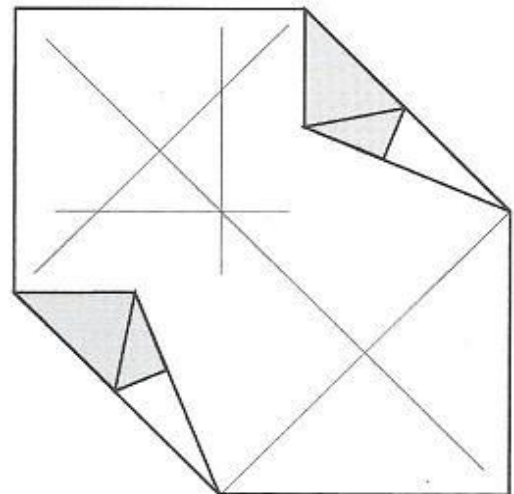

7-C

Steps 8-92 Black swan

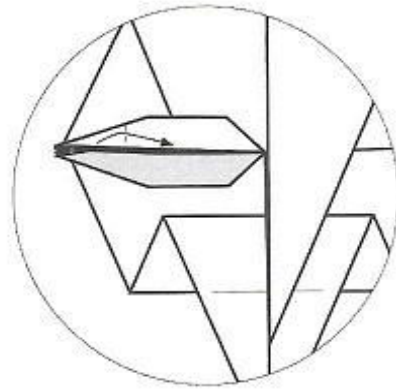

93

Steps 94-98 Black swan

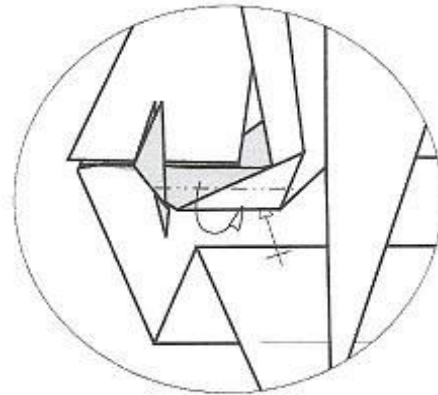

99

Steps 100-117 Black swan

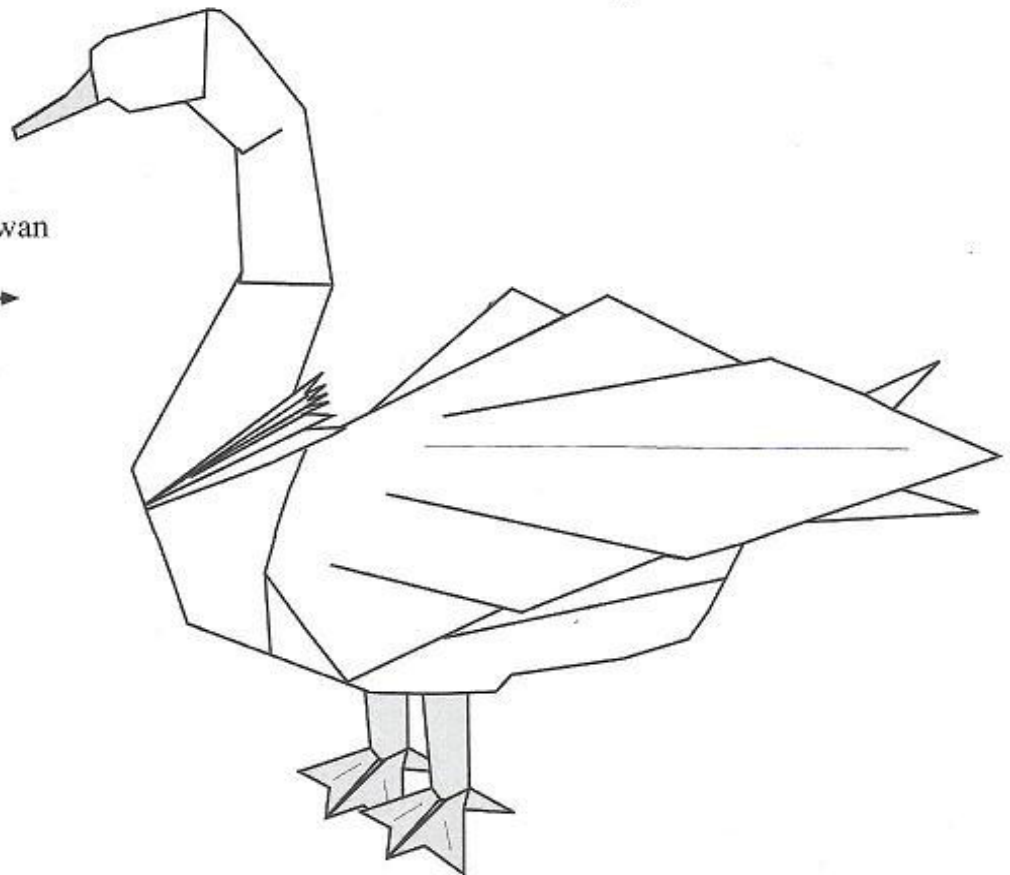

118

119

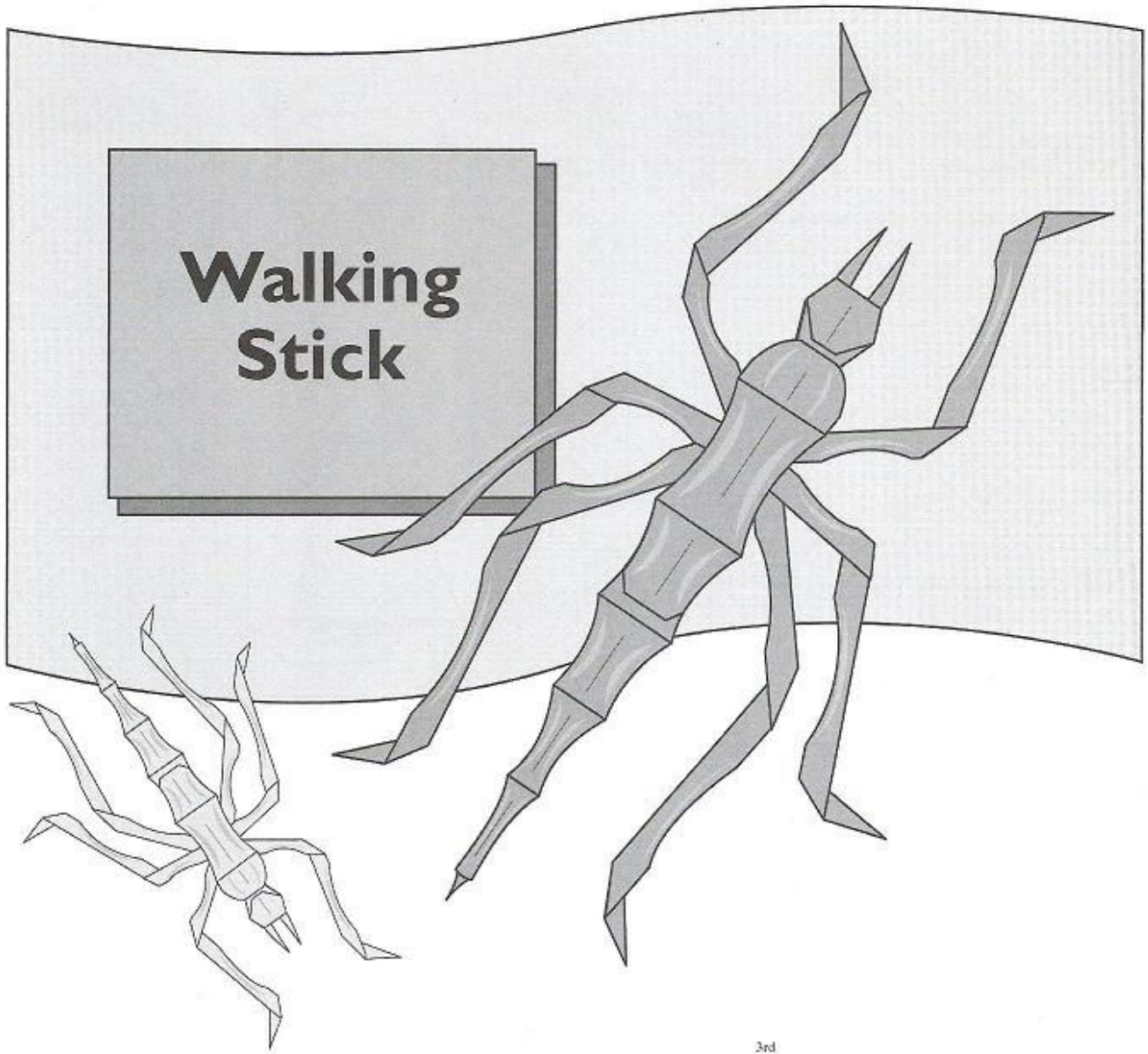

The paper should be green. Fine paper is recommended, less than 30 grams, silk, banana tree, lokta, metallic, or "sandwich" of 7.9x7.9 inches (20x20 cm) or bigger.

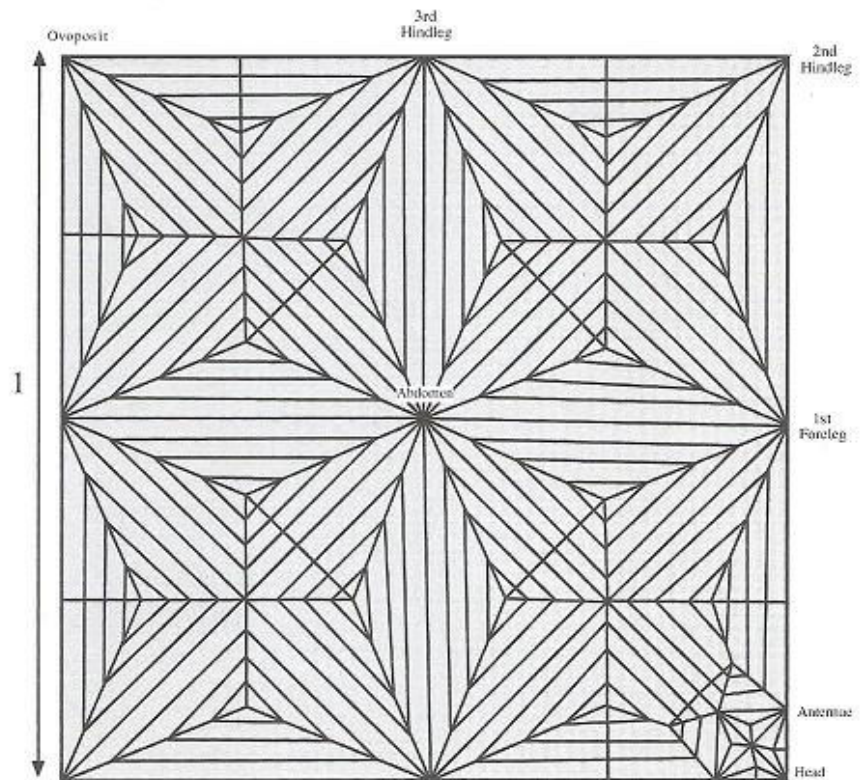
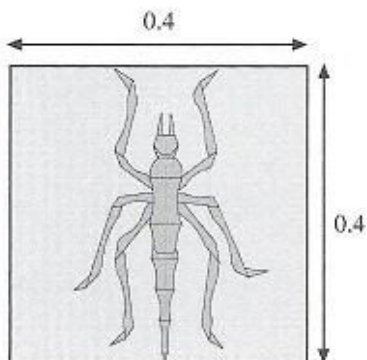

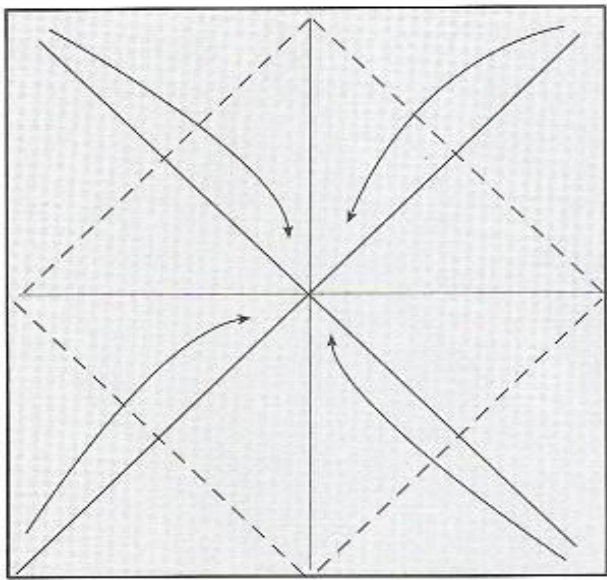

1 

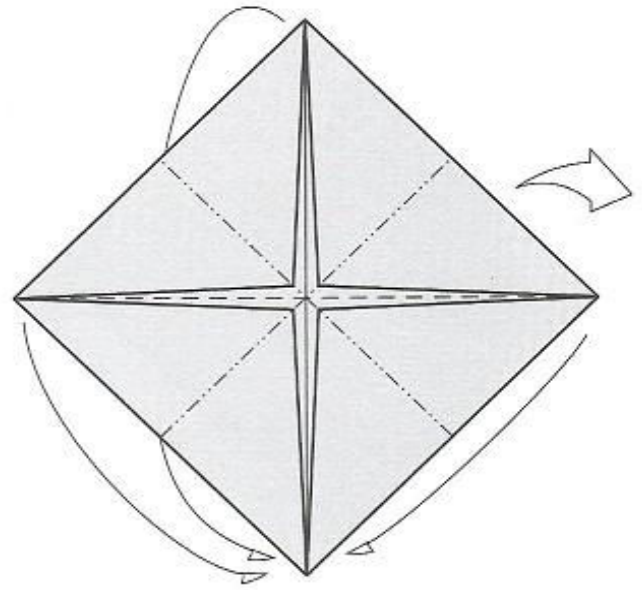

2

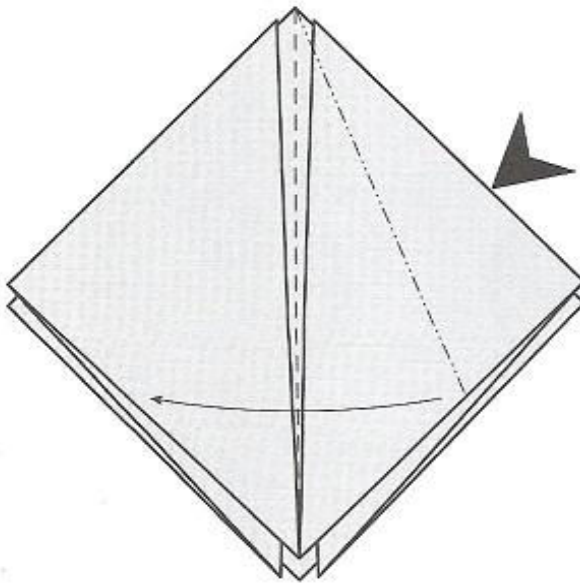

3

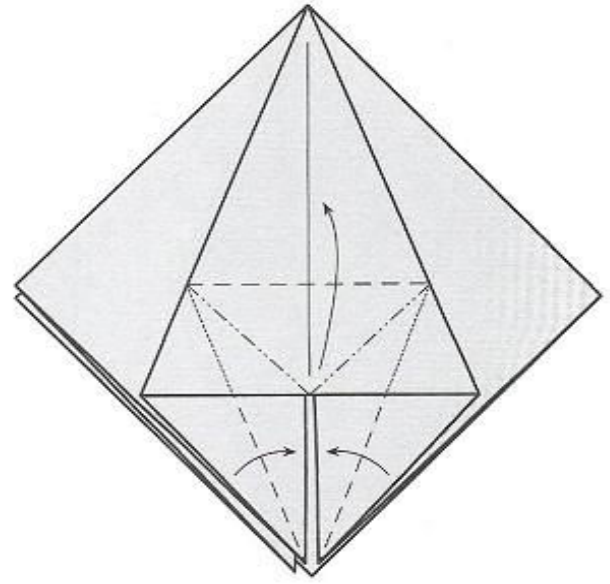

4

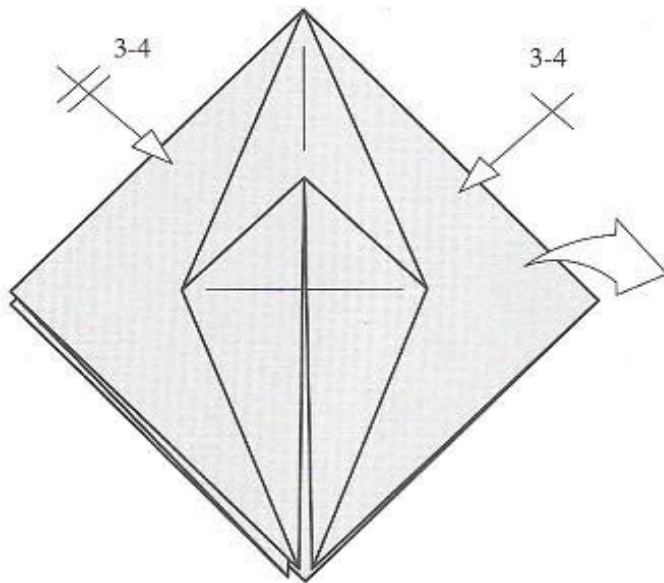

5

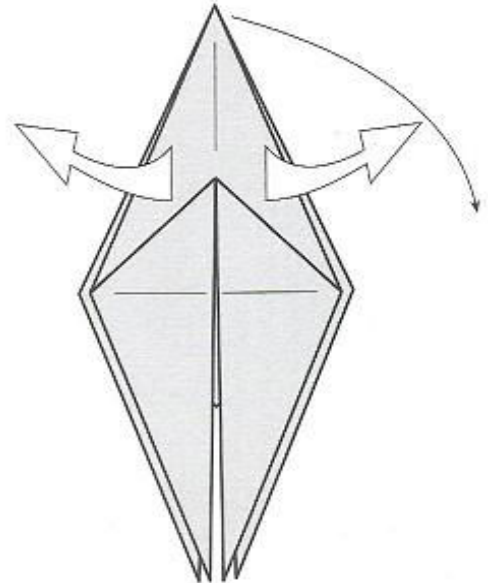

6

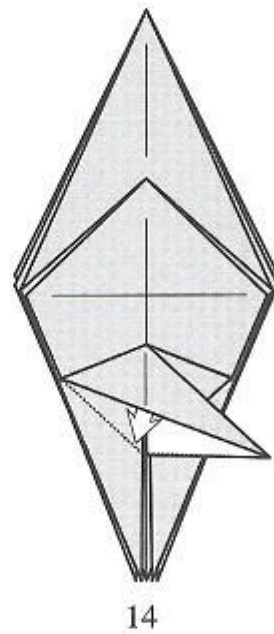
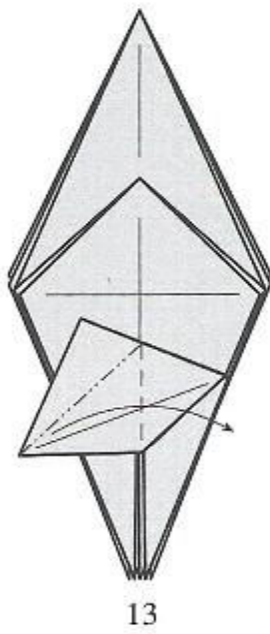
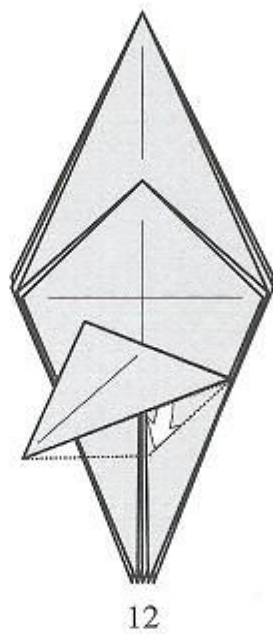
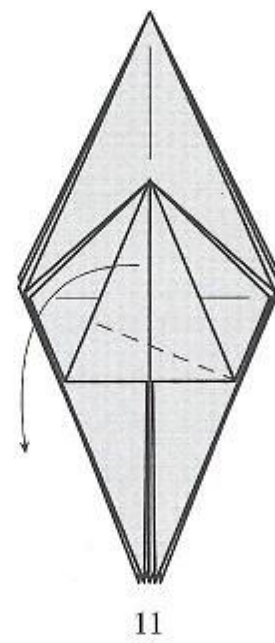
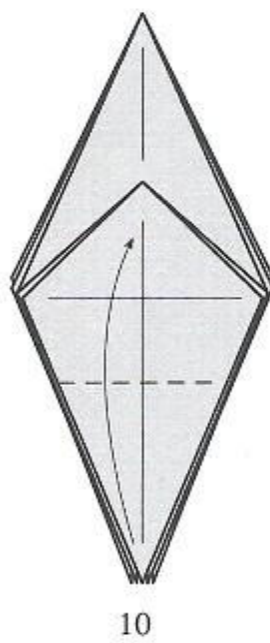
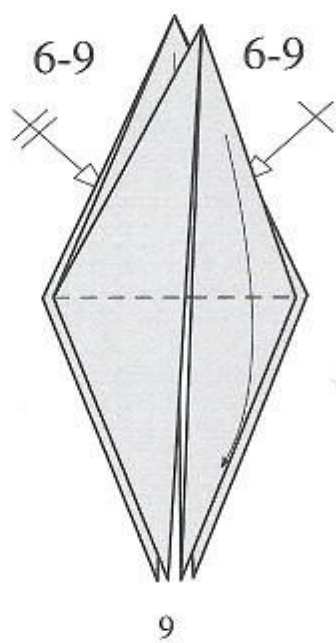
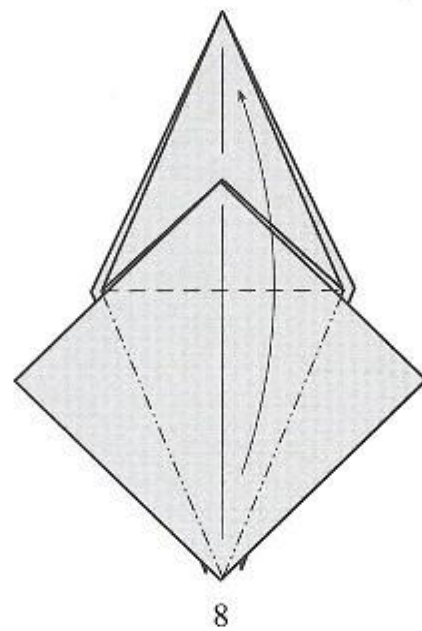
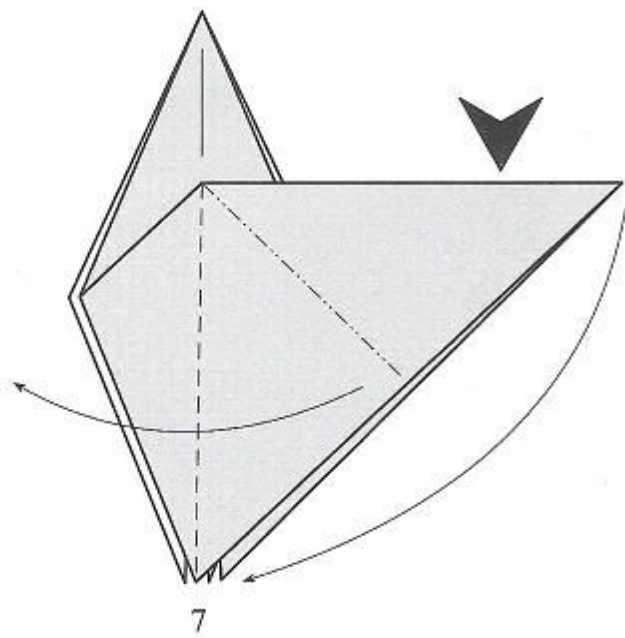

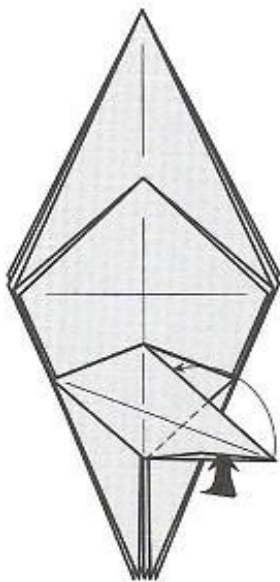

15

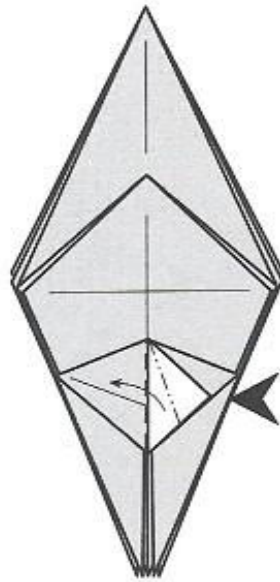

16

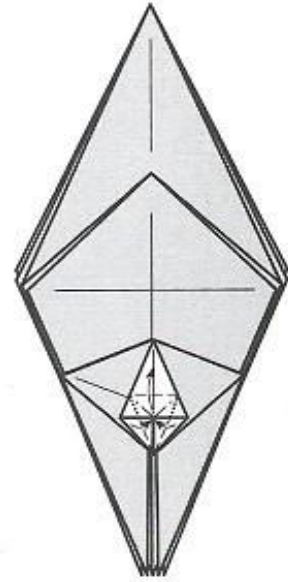

17

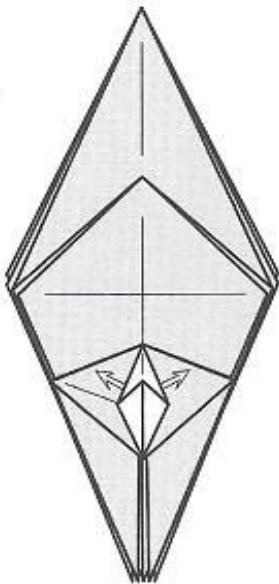

18



19



20

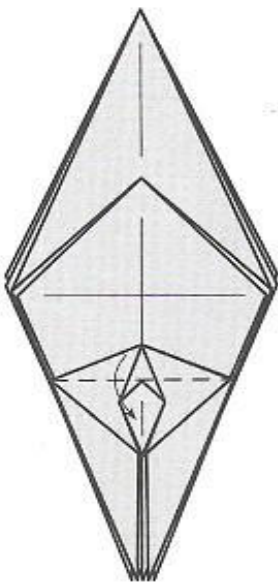

21

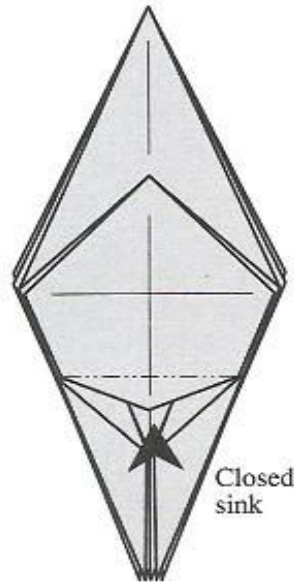

22

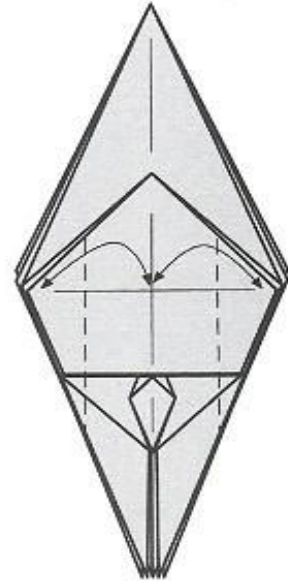

23

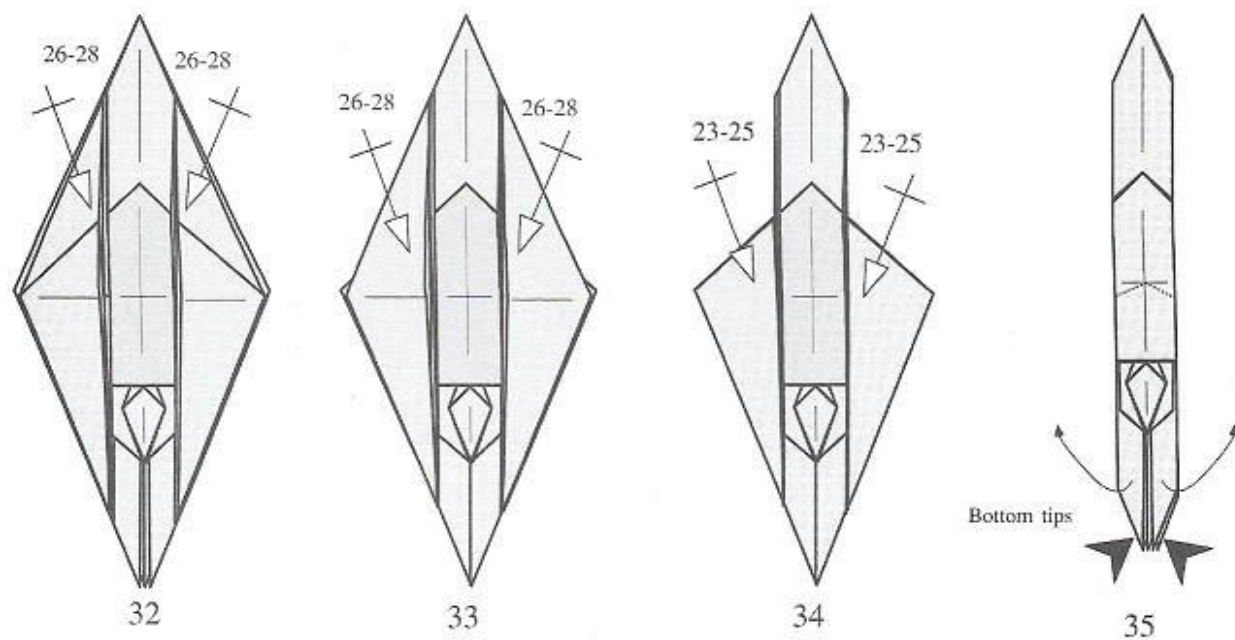
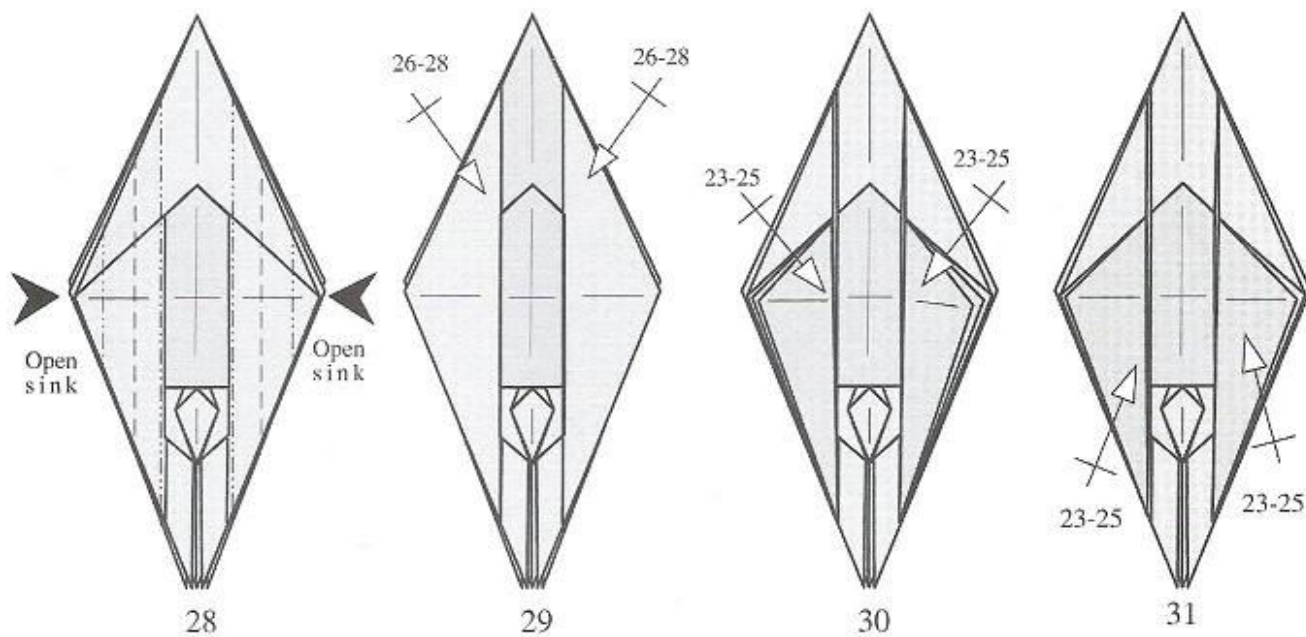
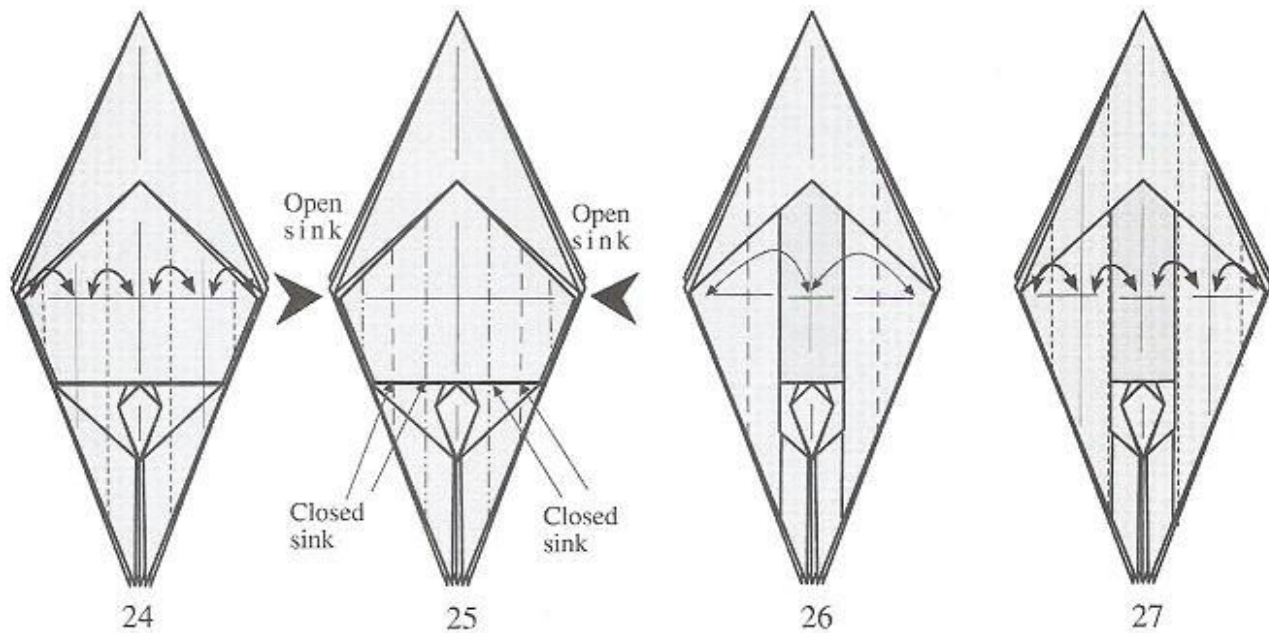

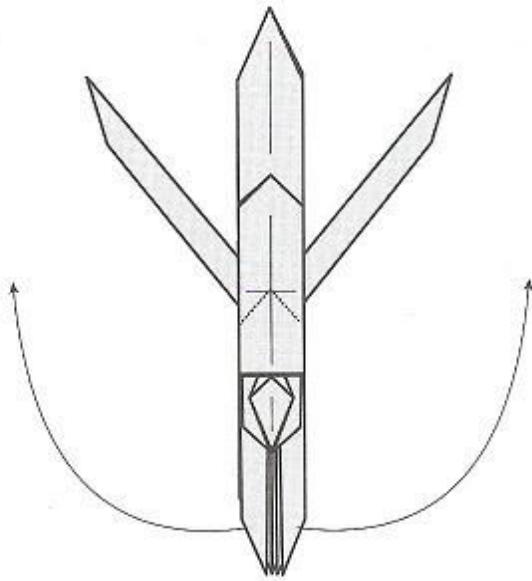

36

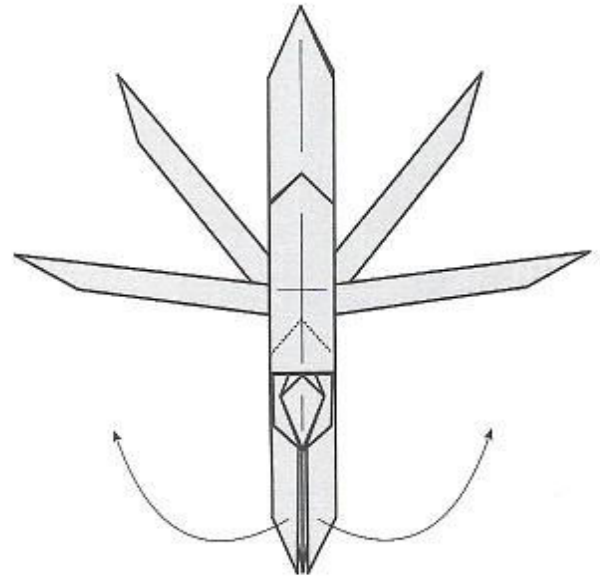

37

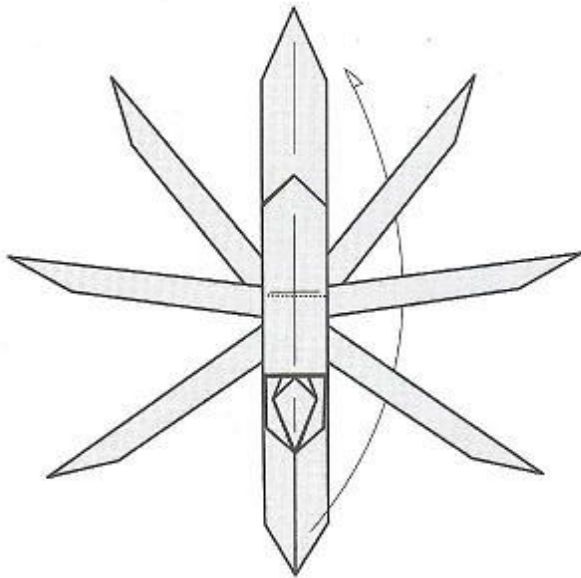

38

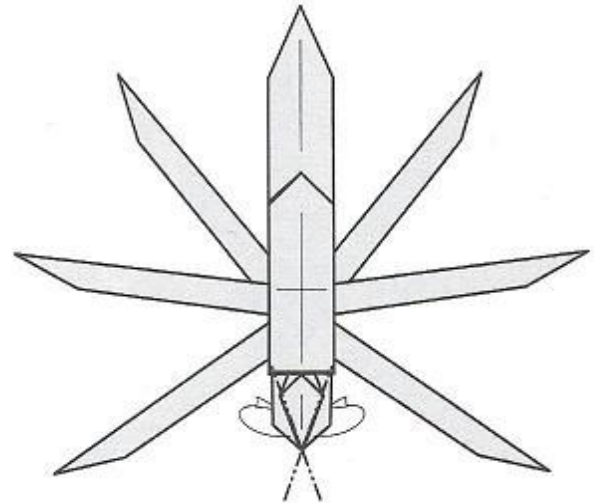

39

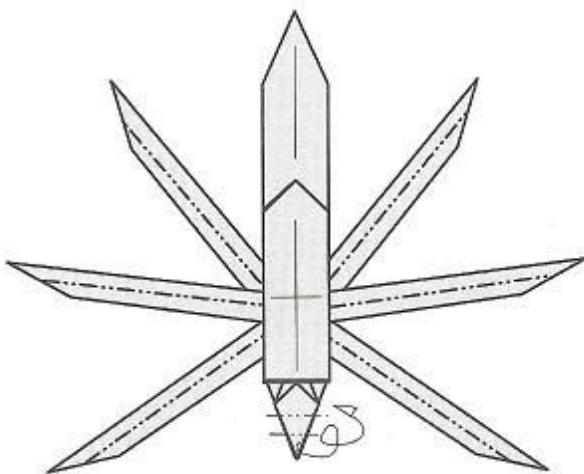

40

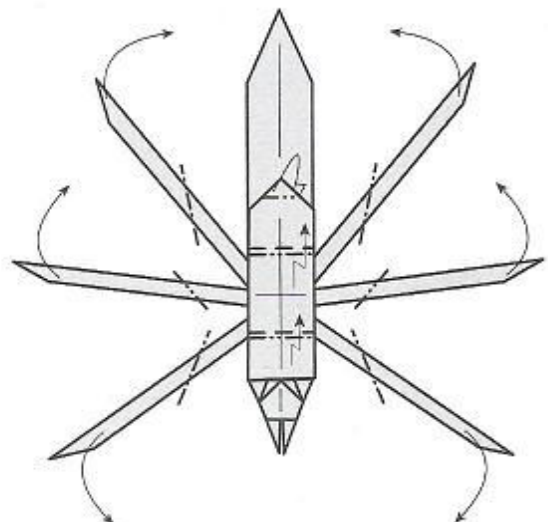

41

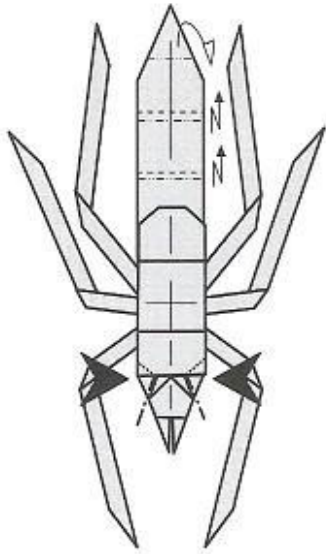

42

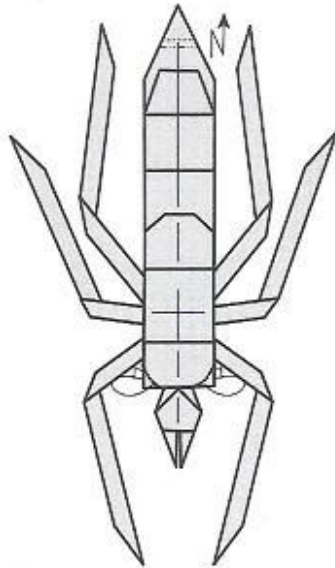

43

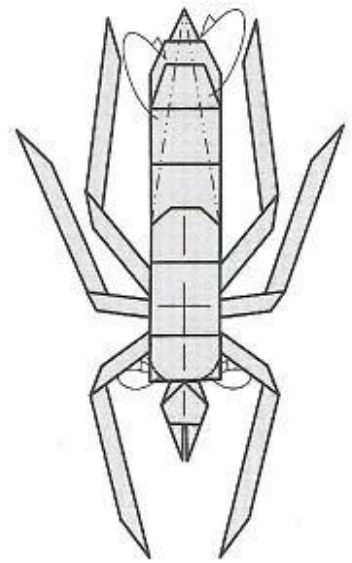

44

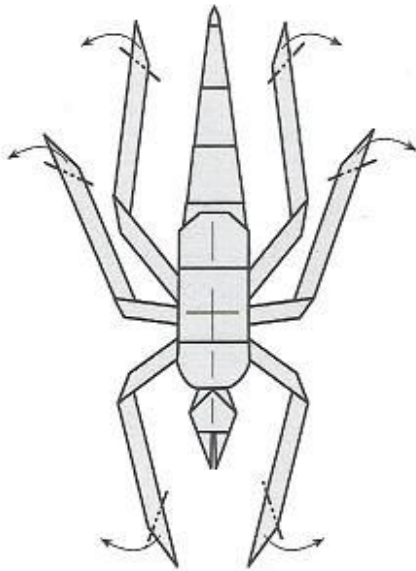

45

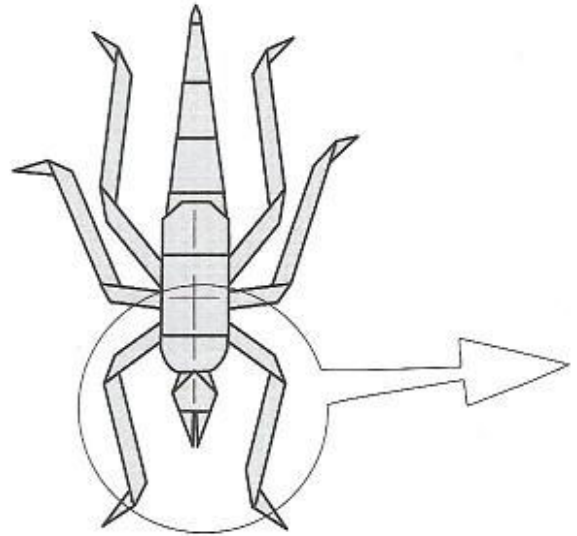

46

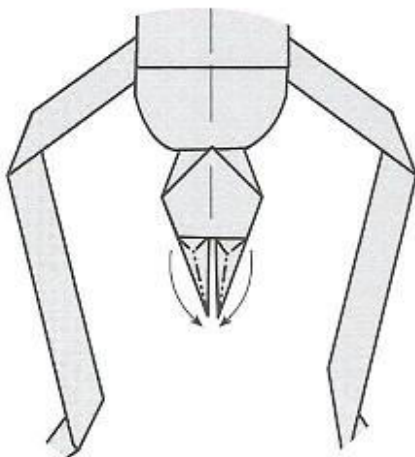

47

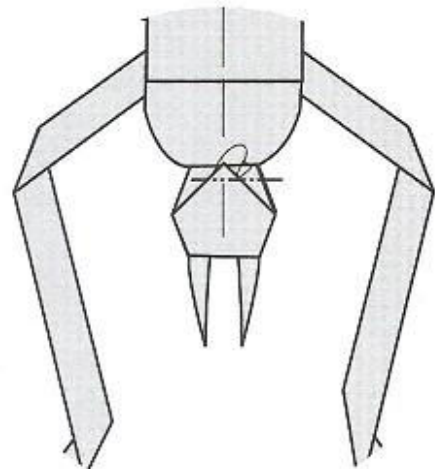

48

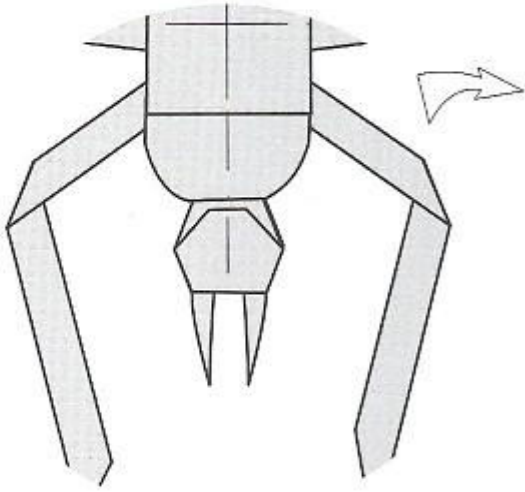

49

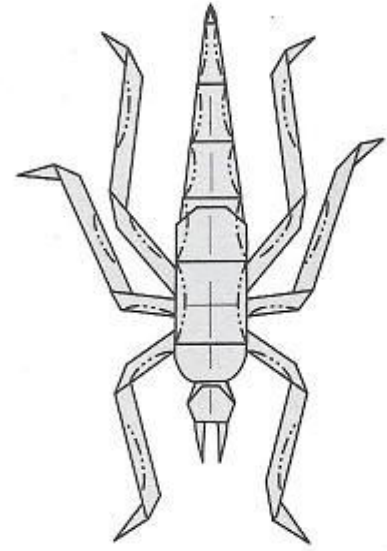

50

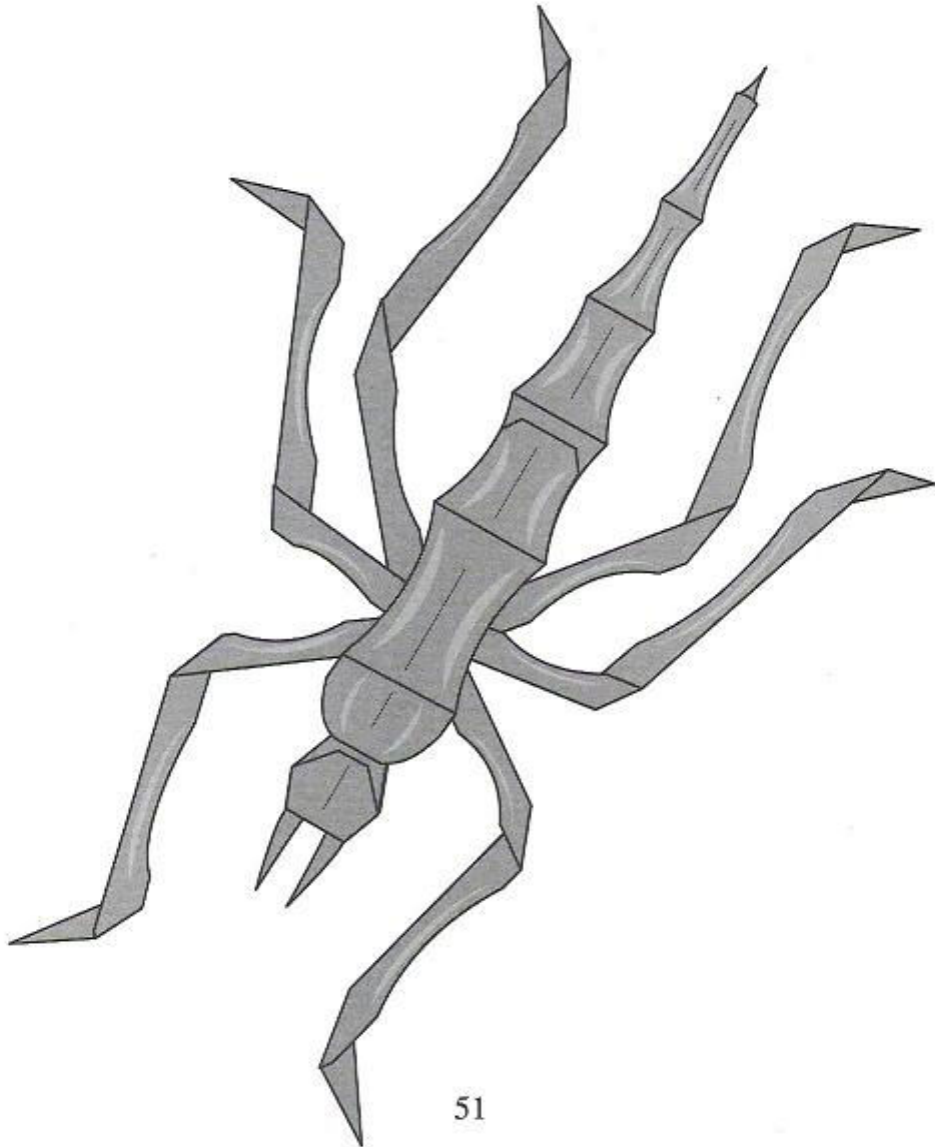

51

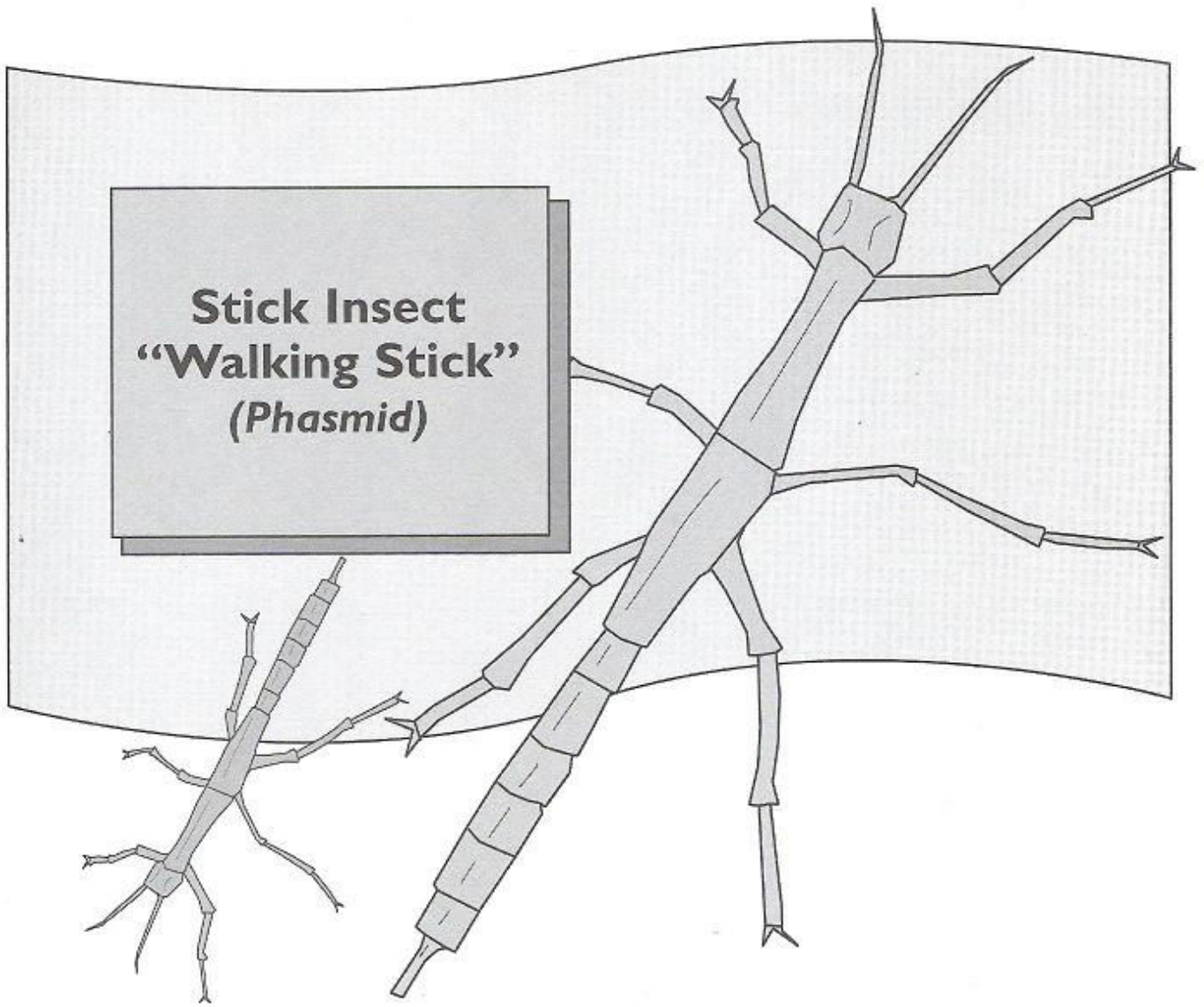

An appropriate color for paper would be light-brown, dark-brown or green. It is recommended to use paper 15.7x15.7 inches (40x40 cm) or bigger and weight less than 30 gr/m².

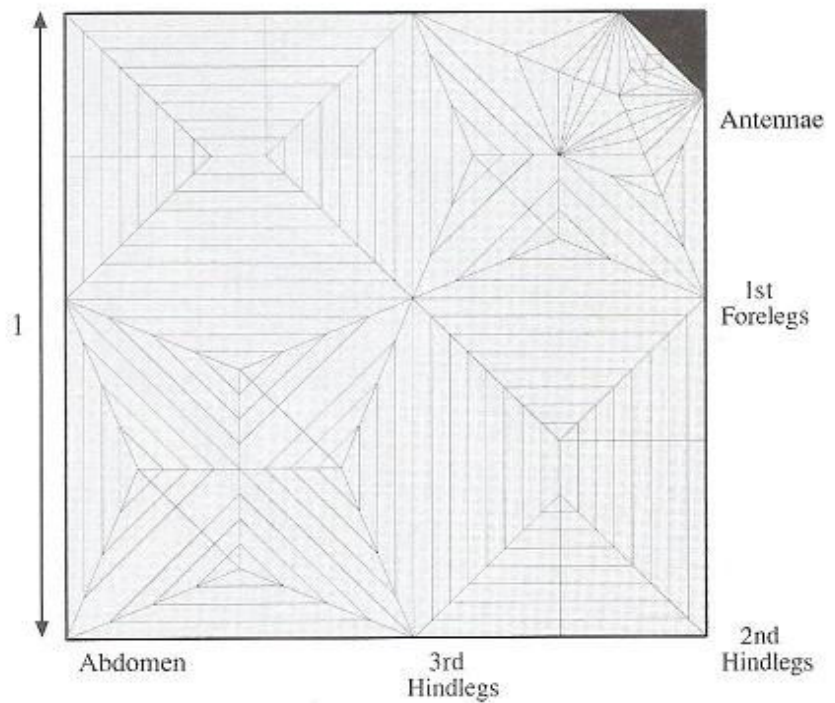
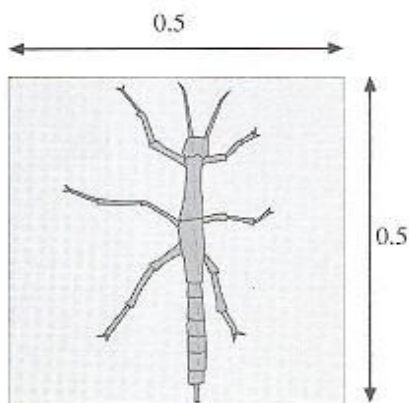

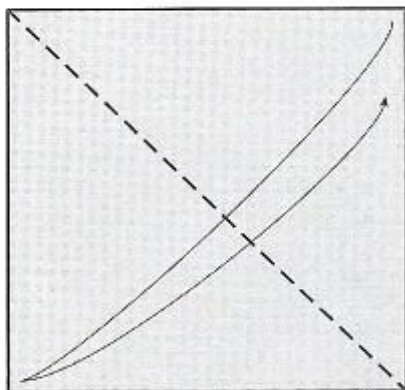

1

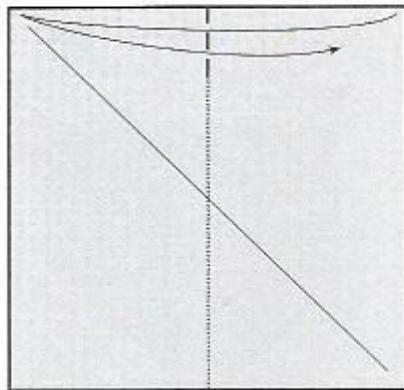

2

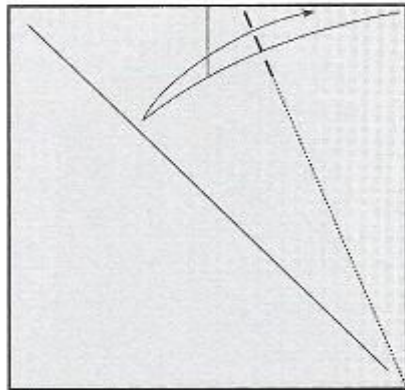

3

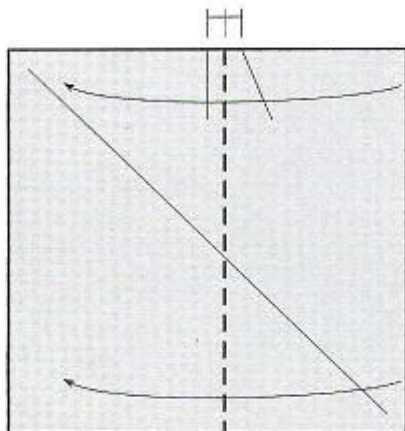

4

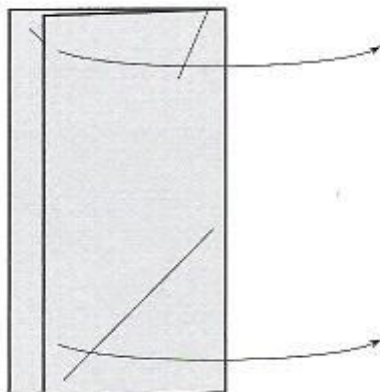

5

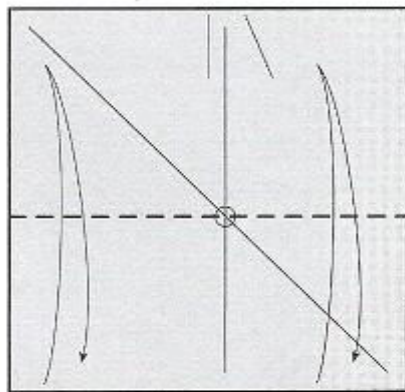

6

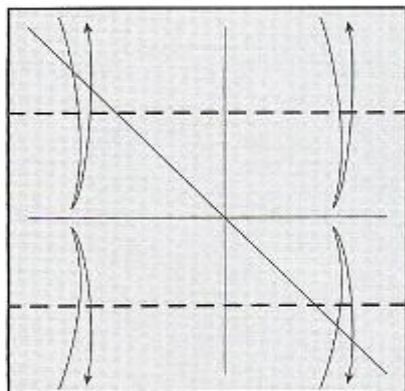

7

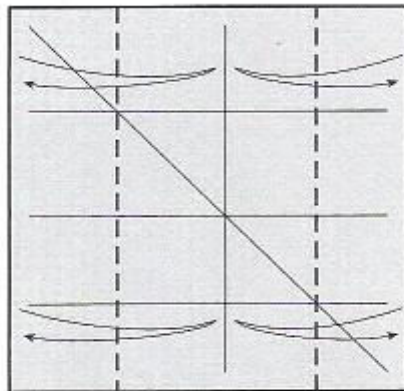

8

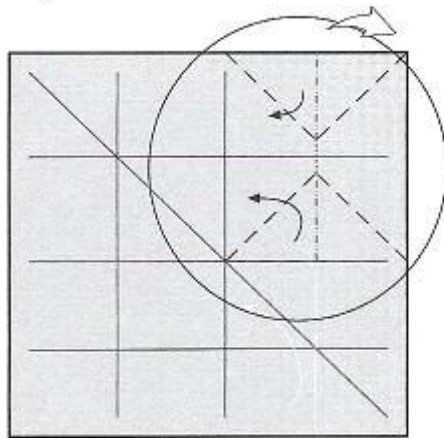

9

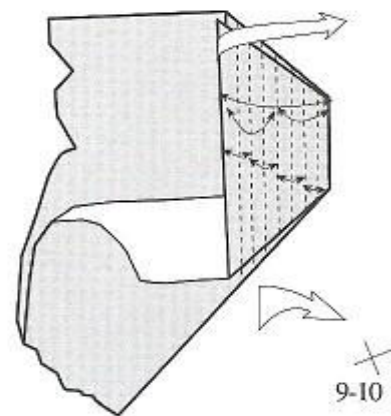

10

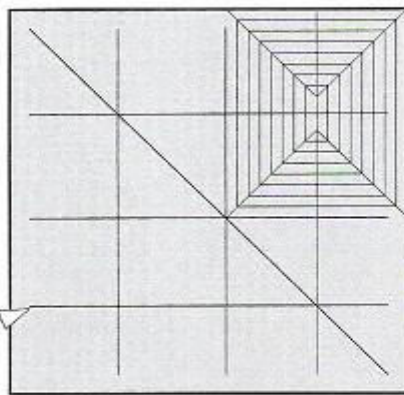

11

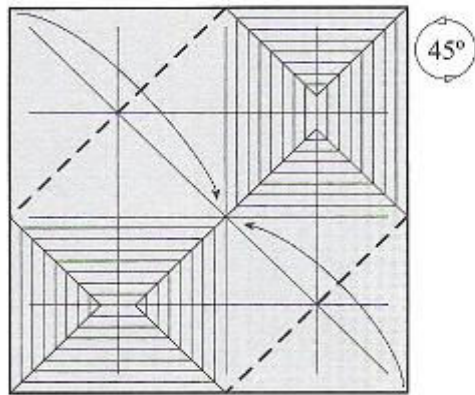

12

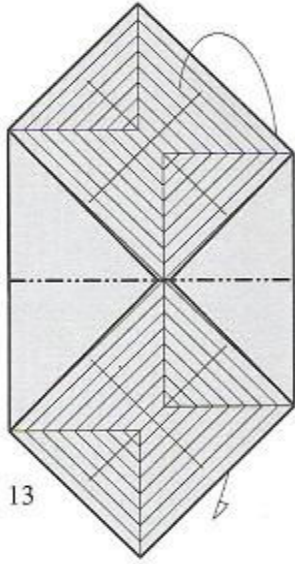

13

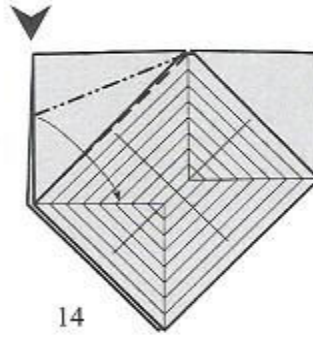

14

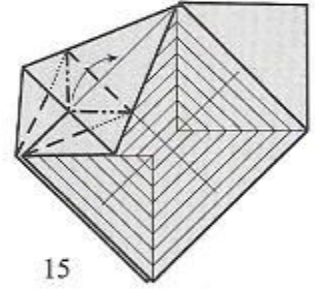

15

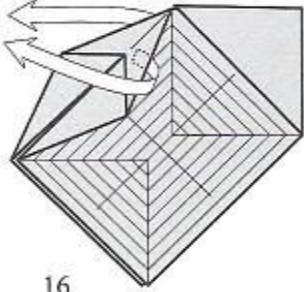

16

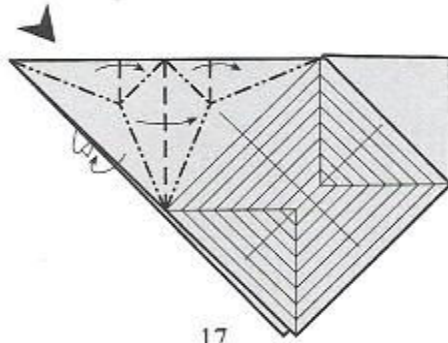

17

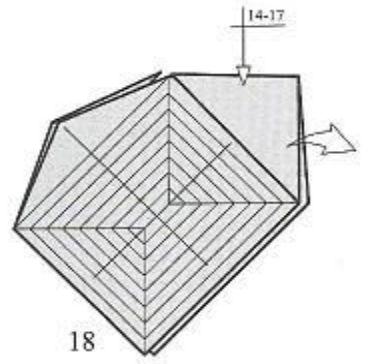

18

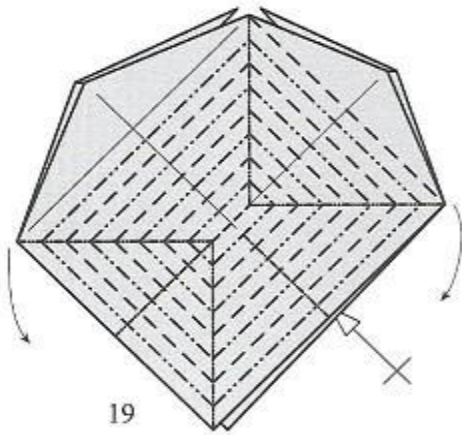

19

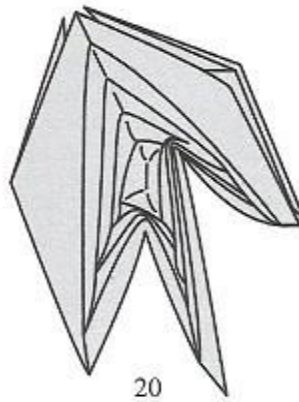

20

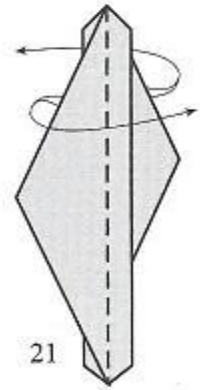

21

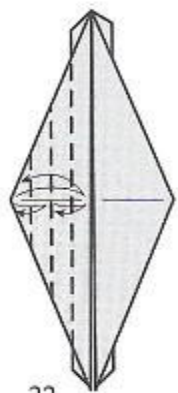

22

Open sink

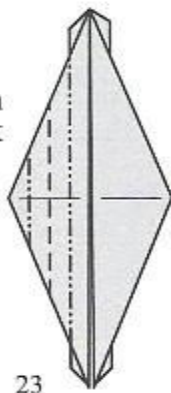

23

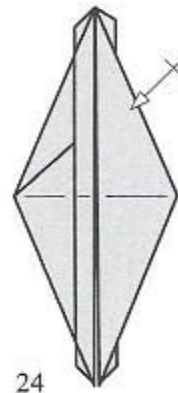

24

22-23

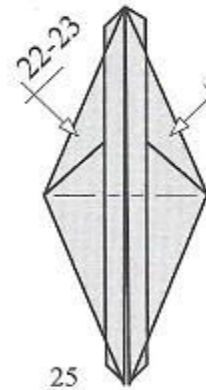

25

22-23

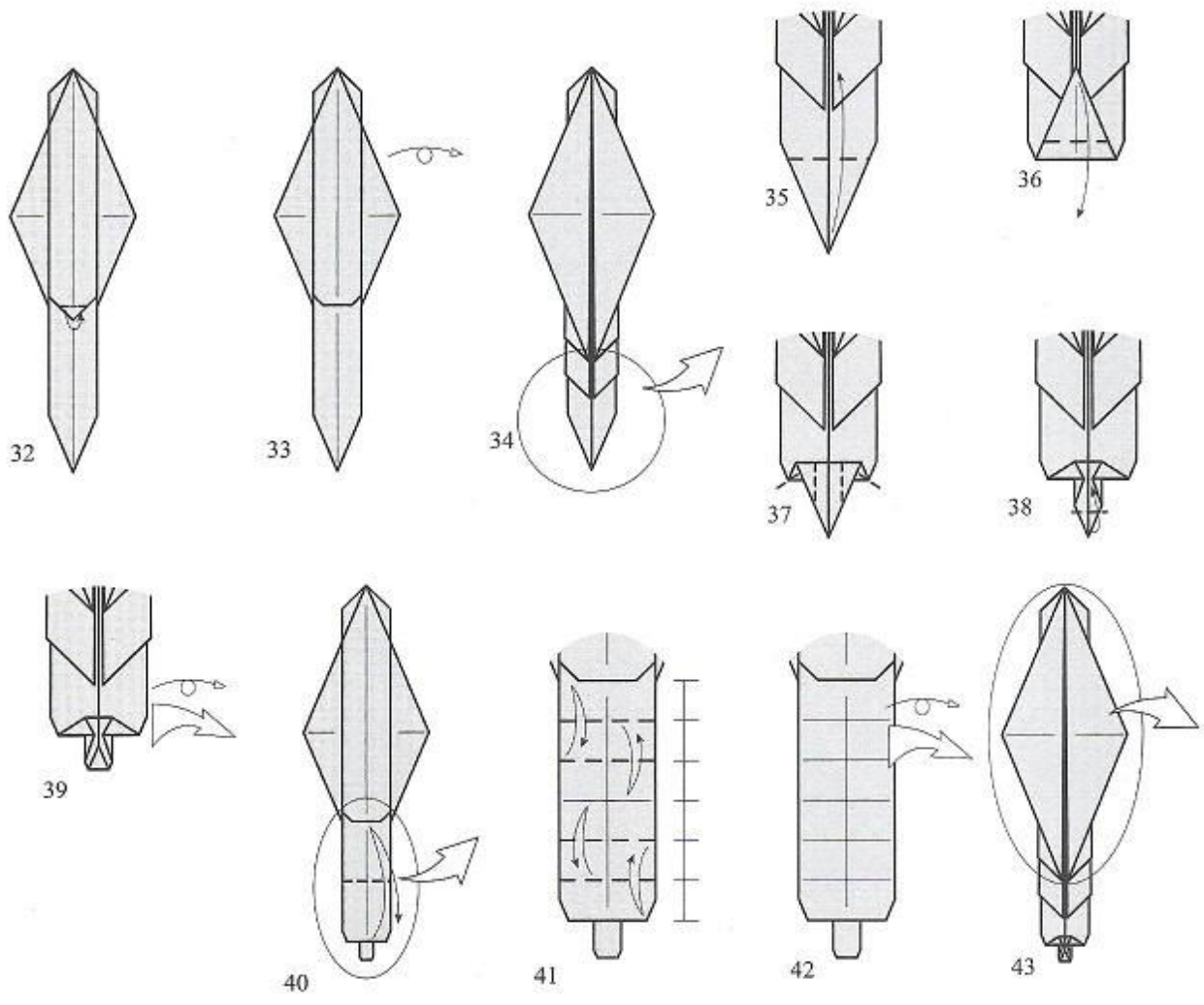
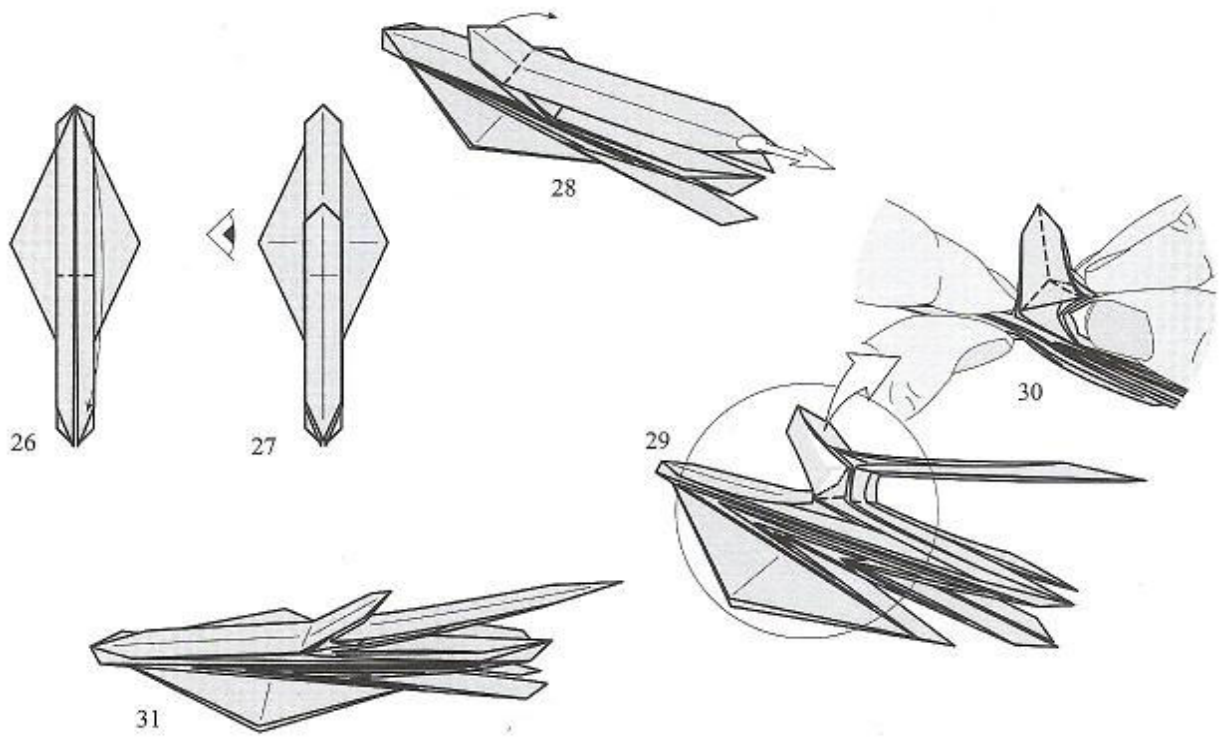

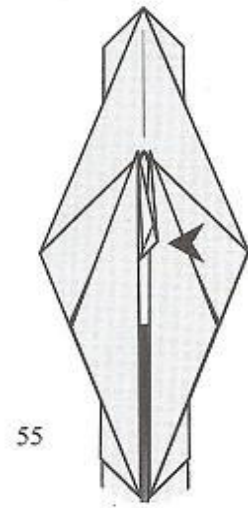
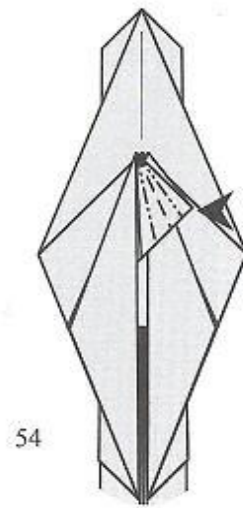
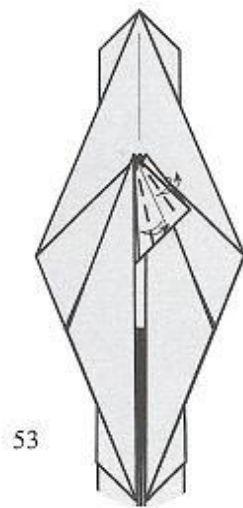
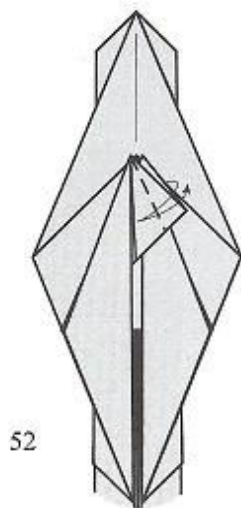
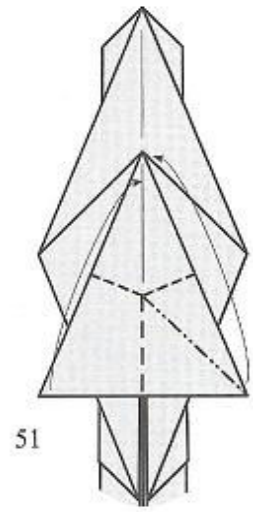
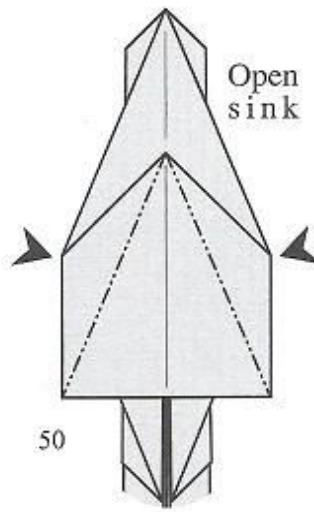
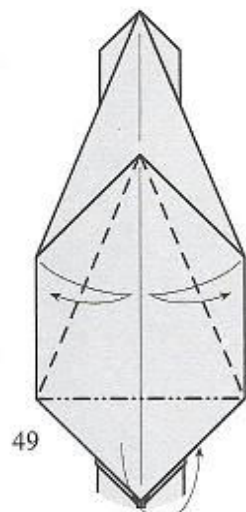
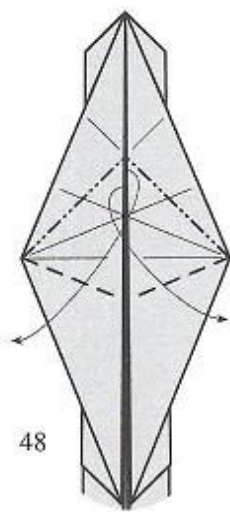
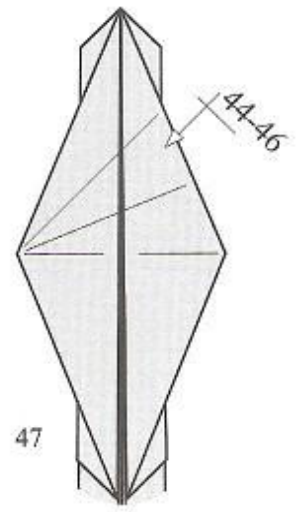
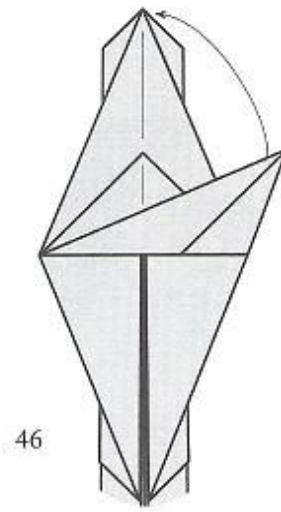
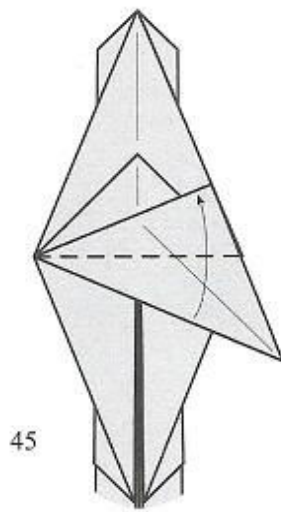
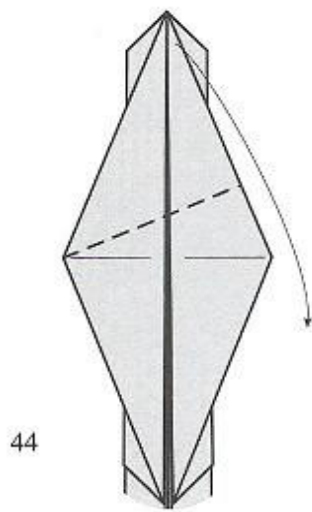

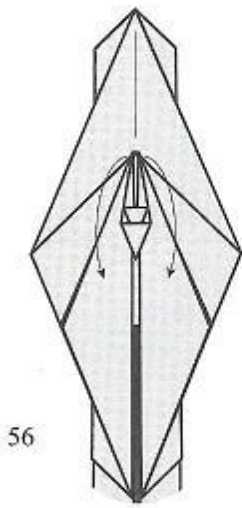

56

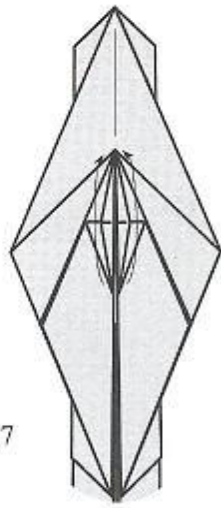

57

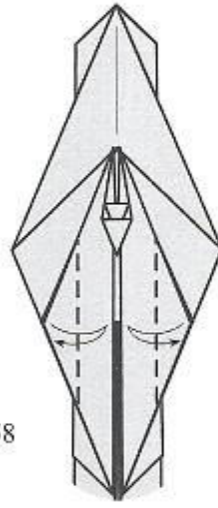

58

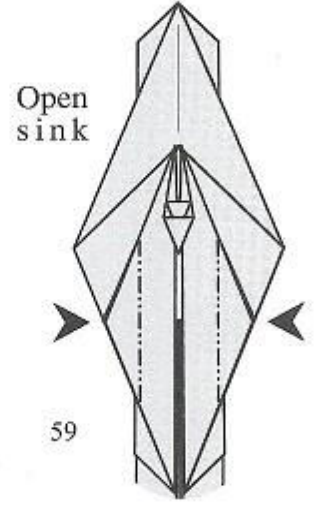

59

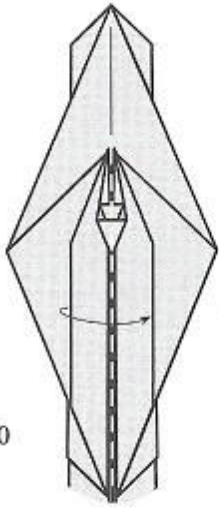

60

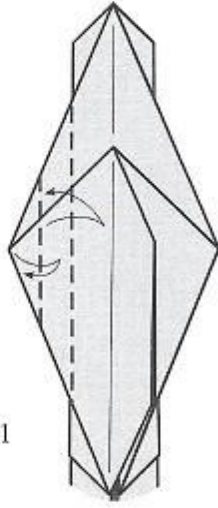

61

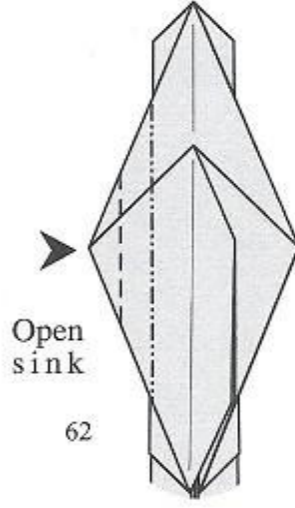

62

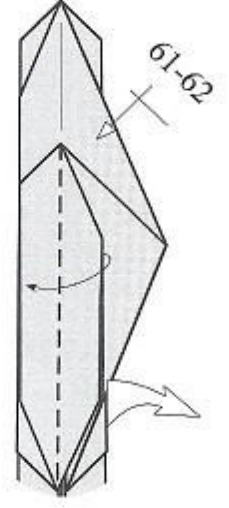

63



64

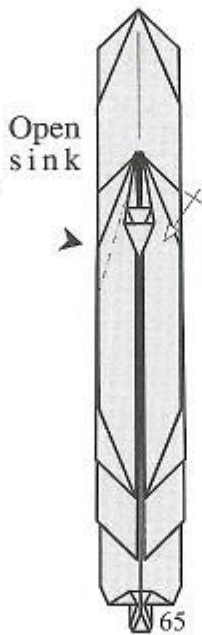

65

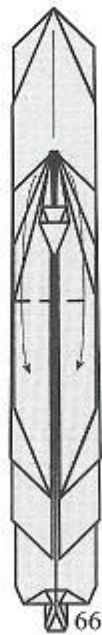

66



67



68



69

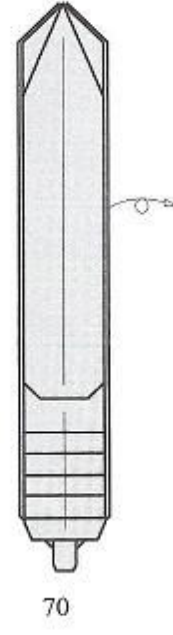

70

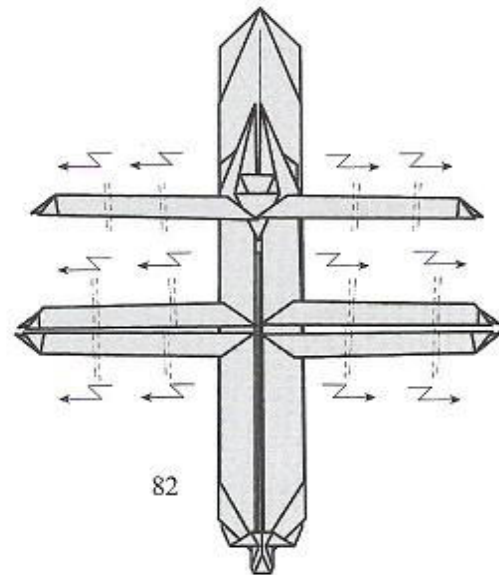
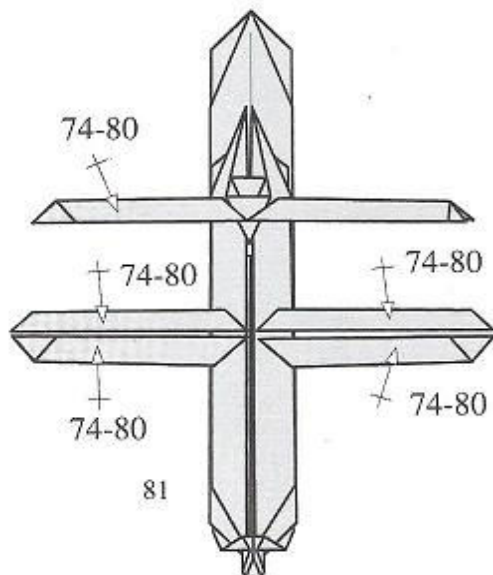
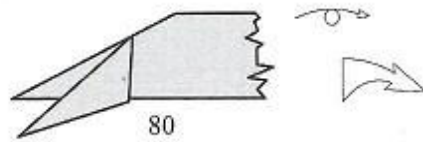
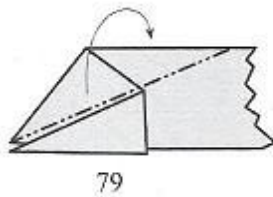
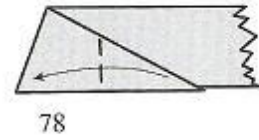
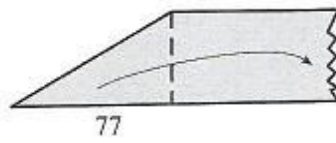
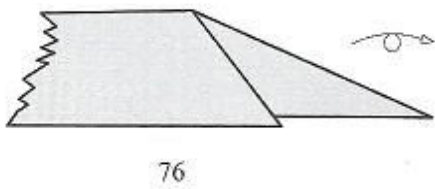
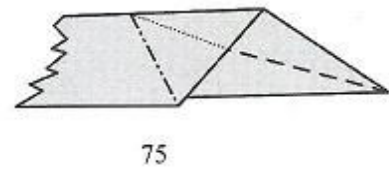
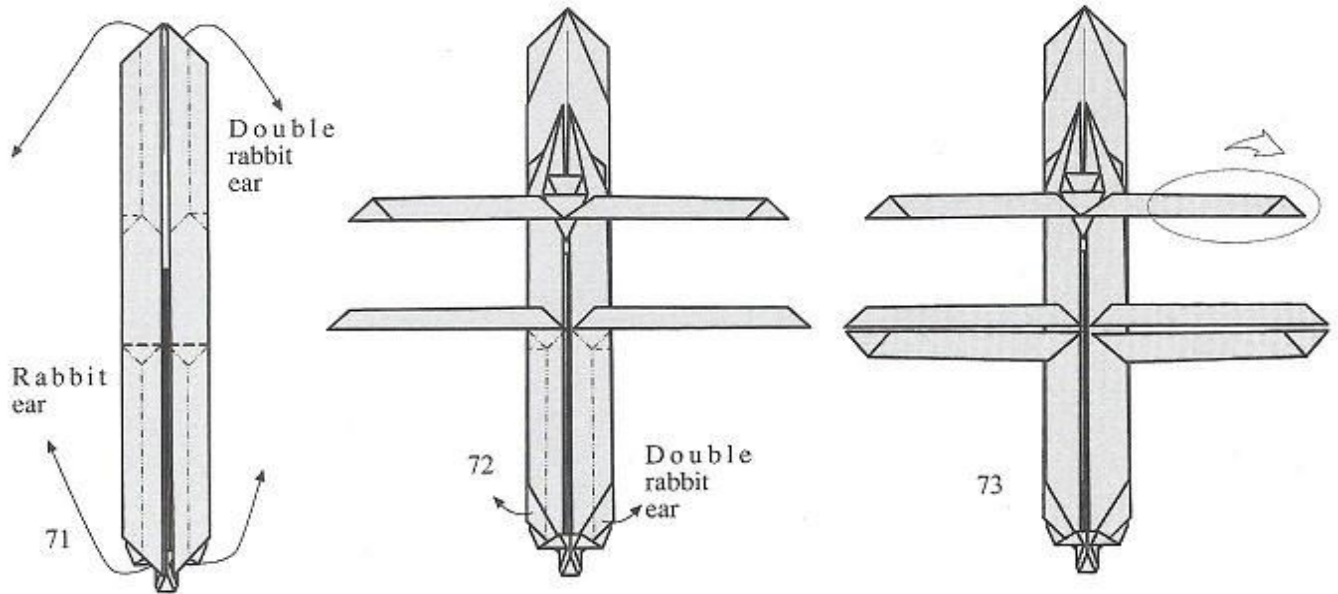

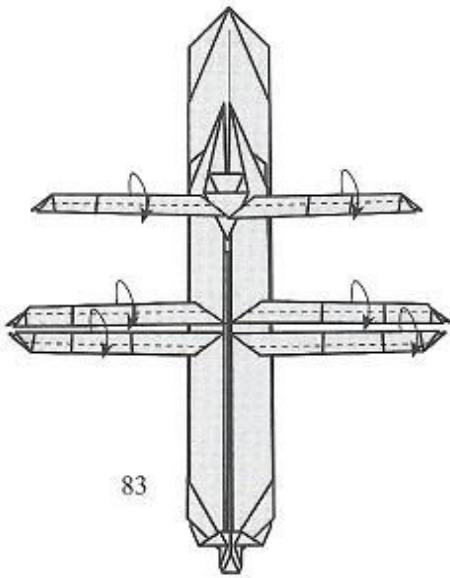

83

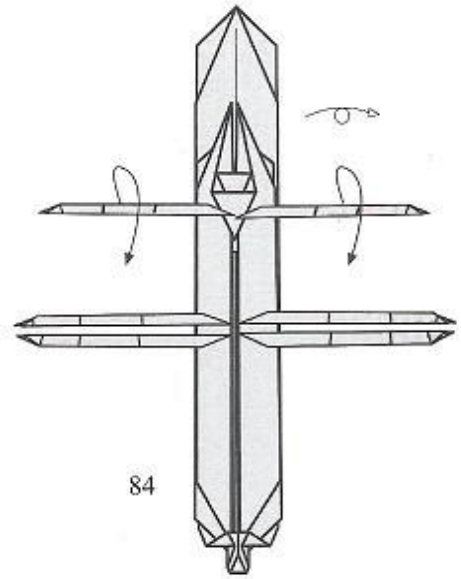

84

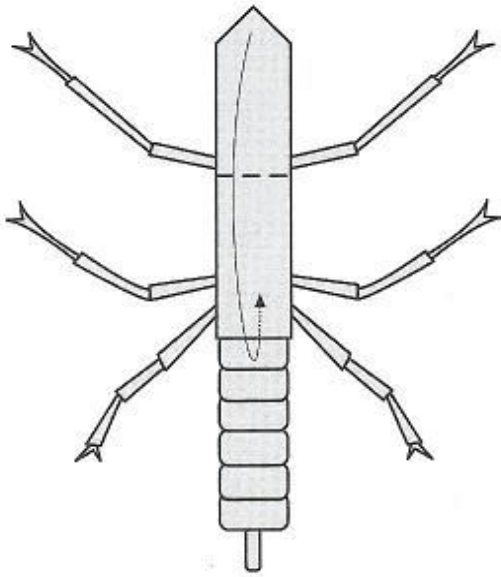

85

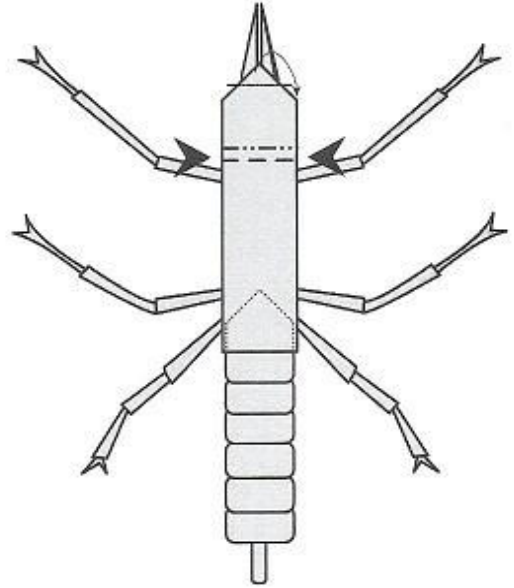

86

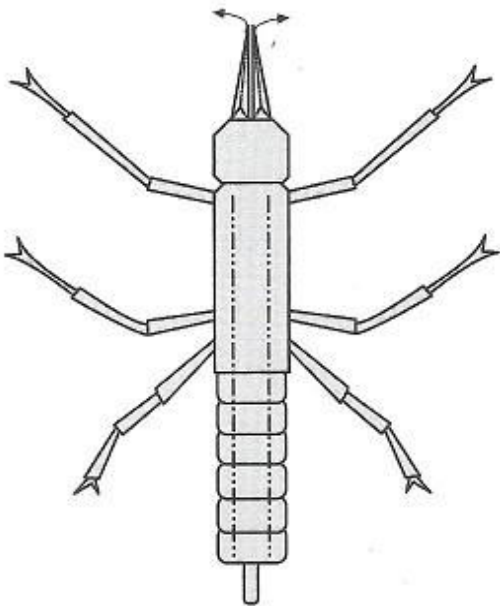

87

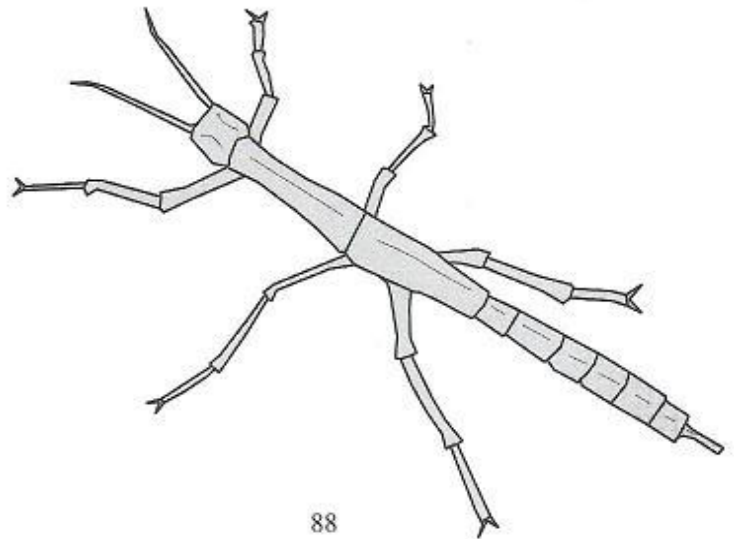

88

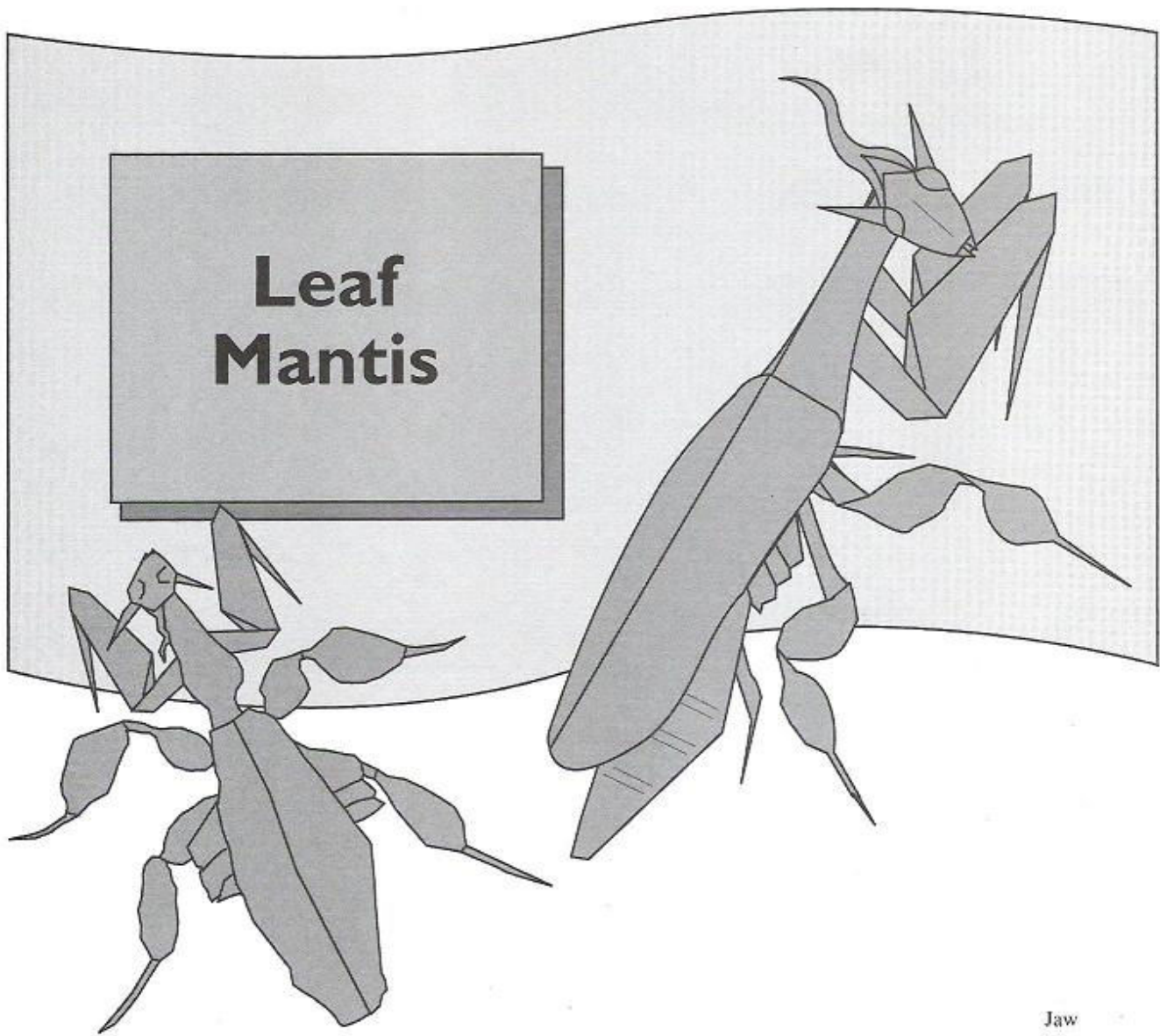

The paper should be brown or green. Fine paper is recommended, less than 40 grams, metallic, double silk or of the type "sandwich," 9.8x9.8 inches (25x25 cm) or bigger.

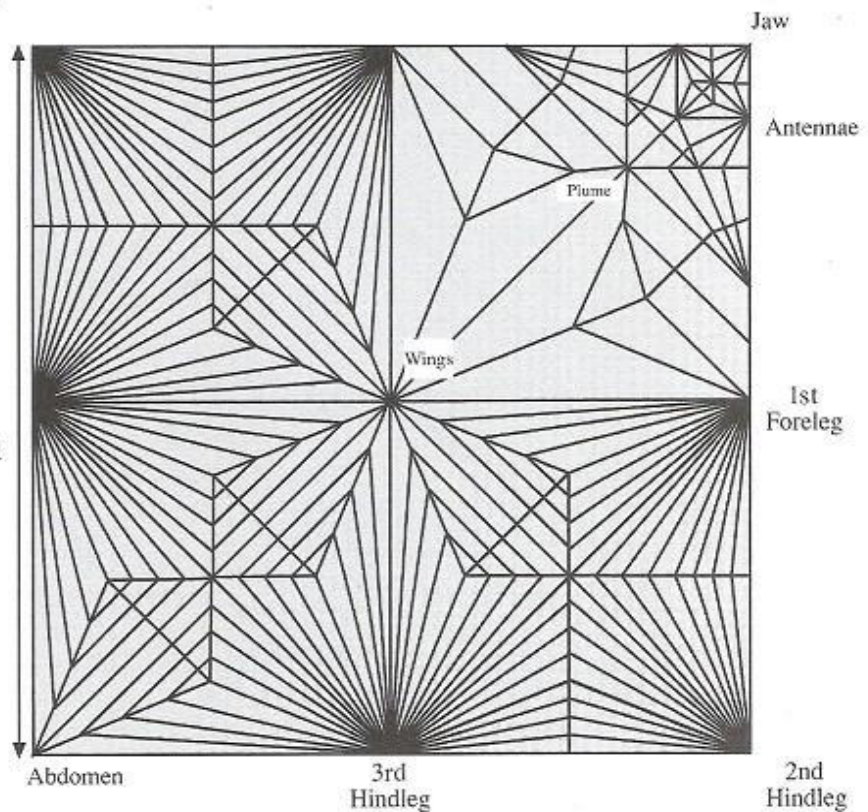
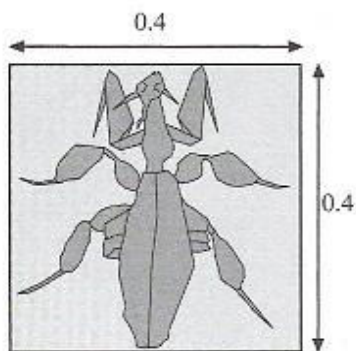

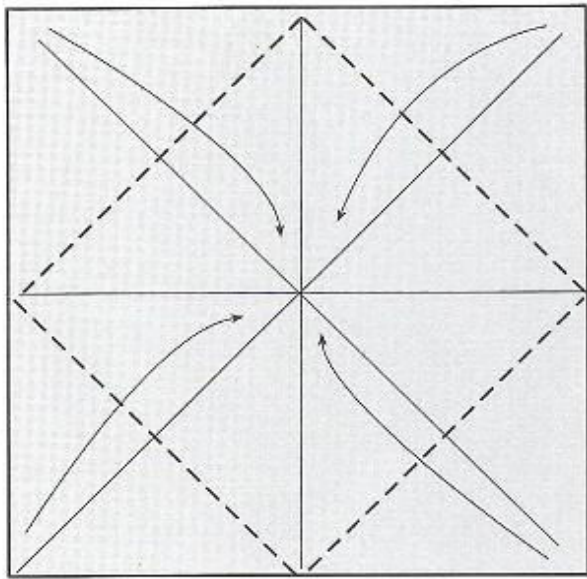

1 

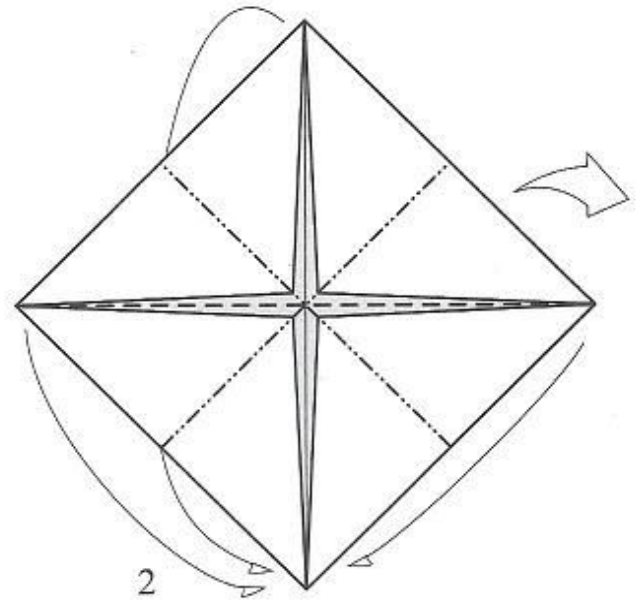

2

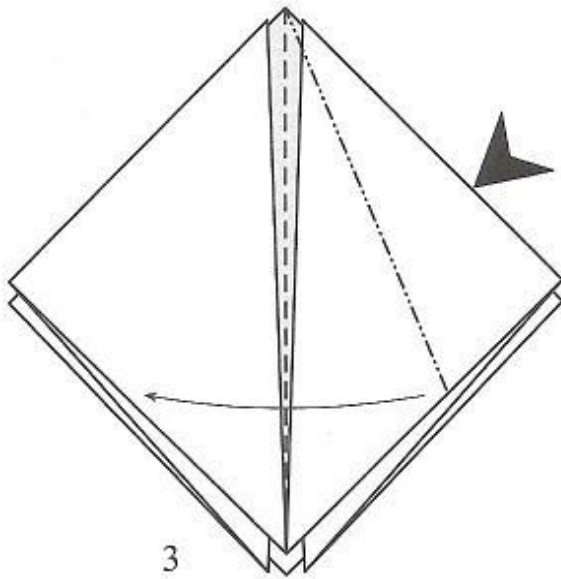

3

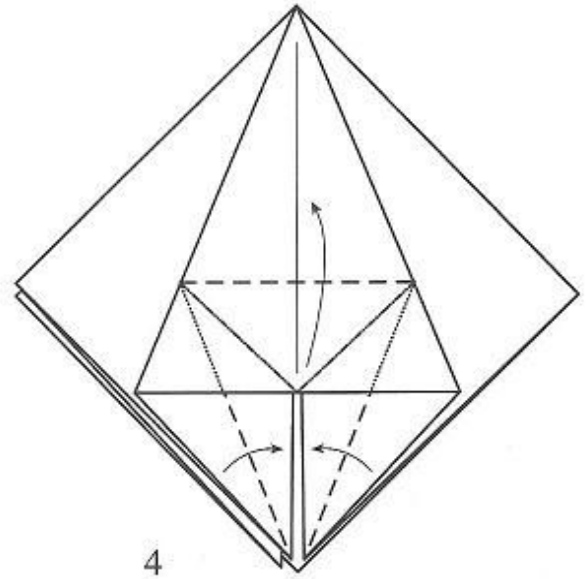

4

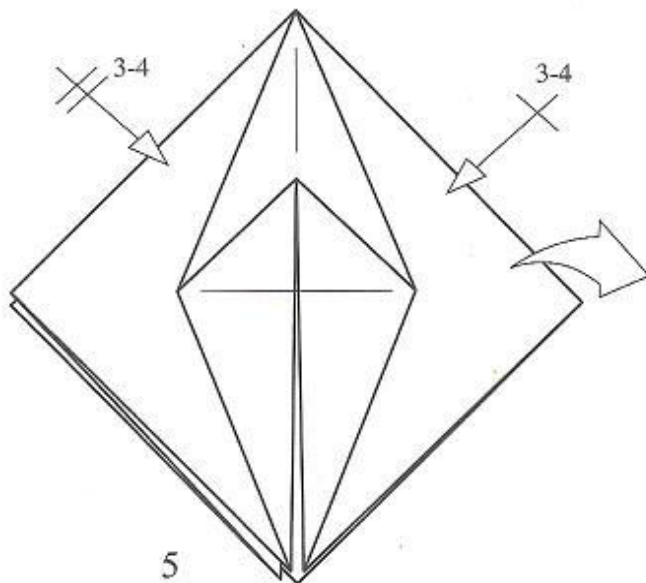

5

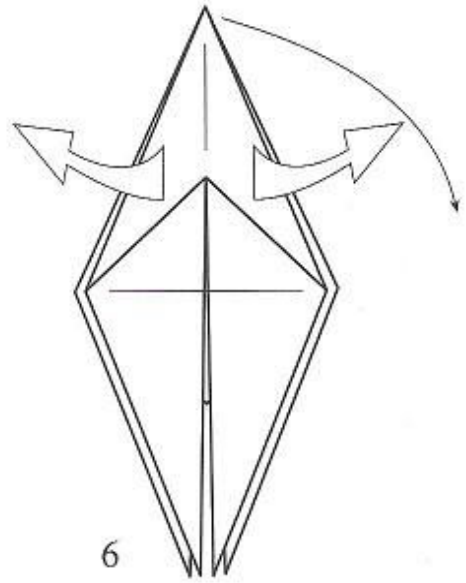

6

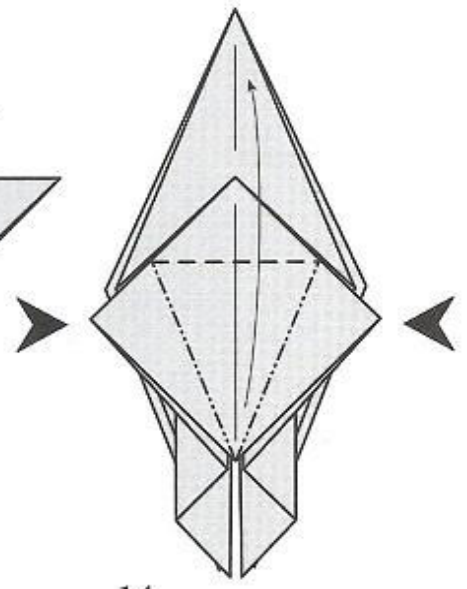
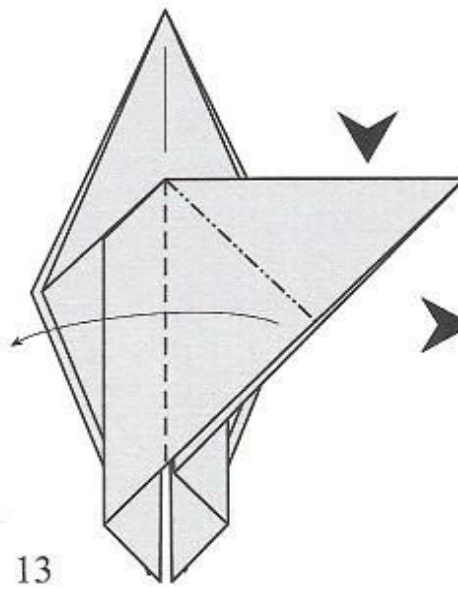
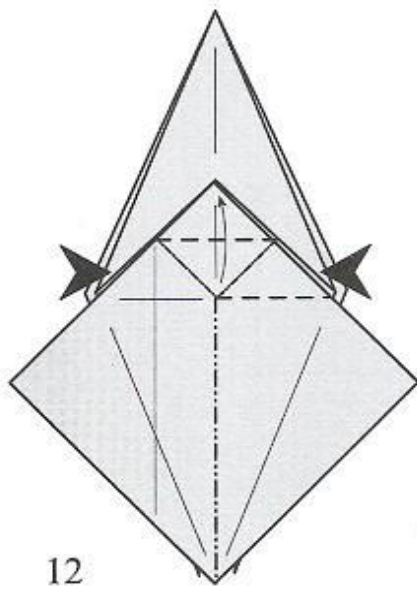
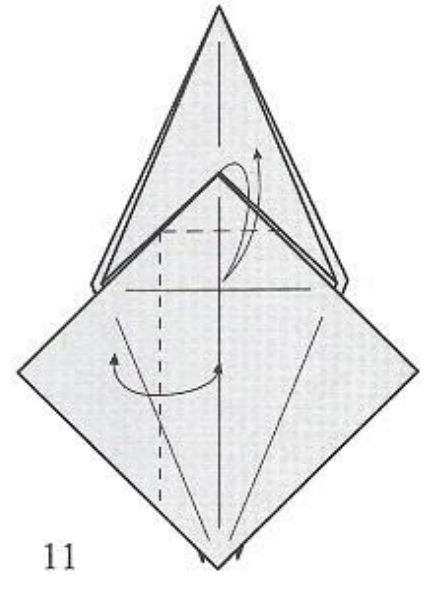
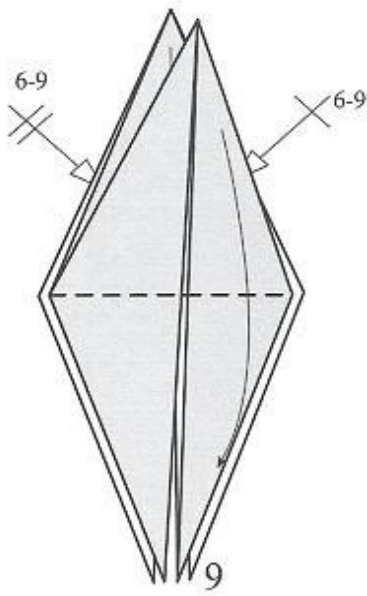
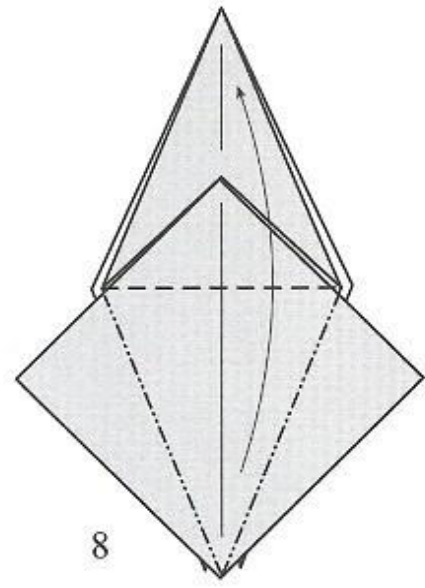
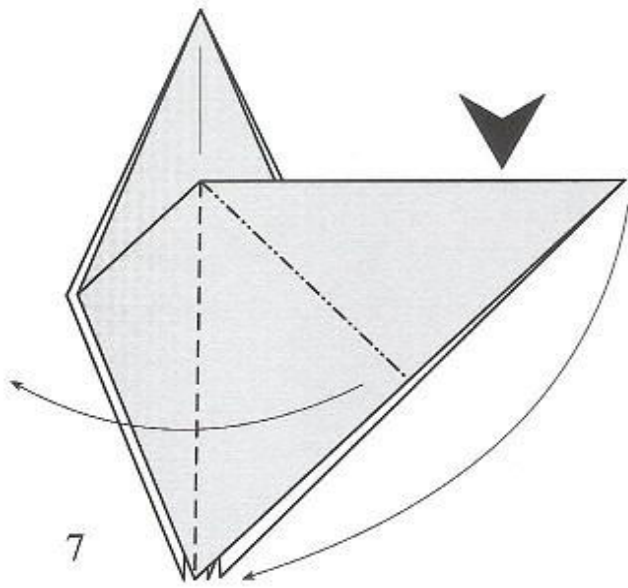

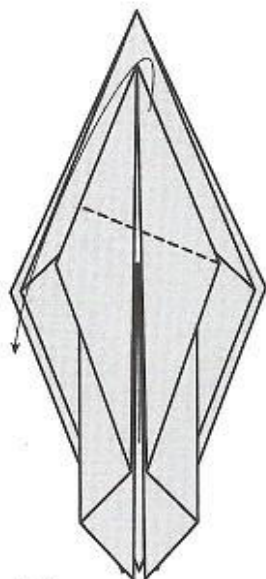

15

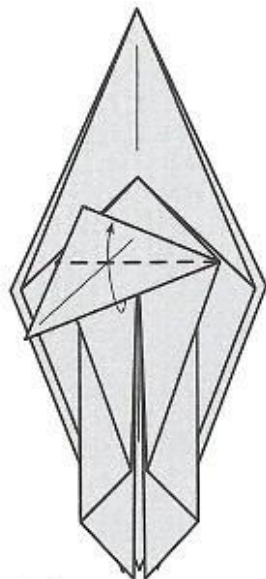

16



17

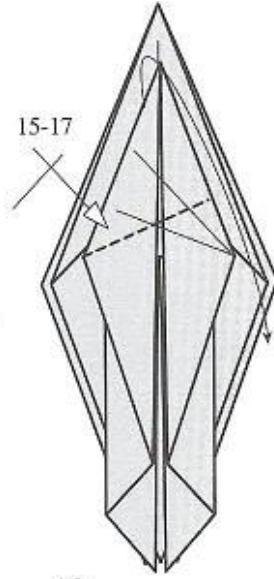

18

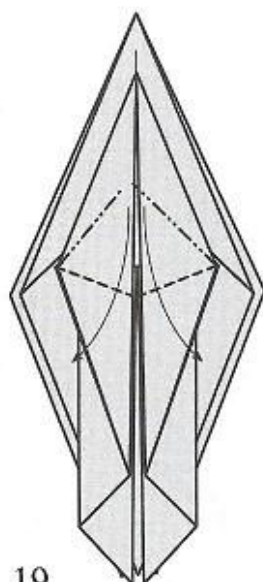

19

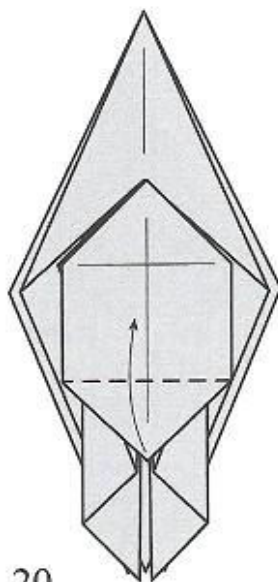

20

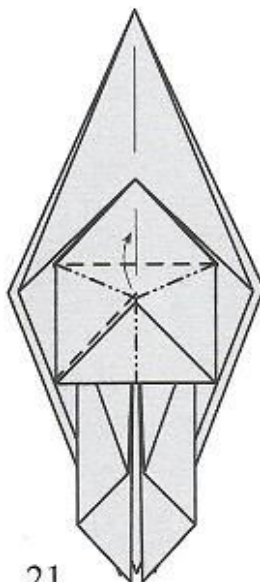

21



22



23

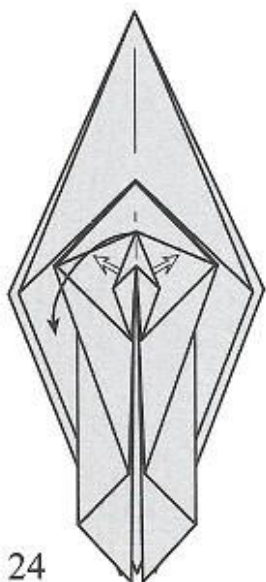

24

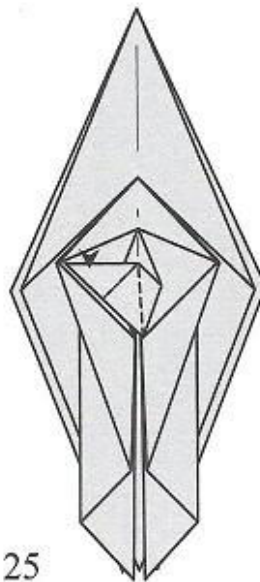

25

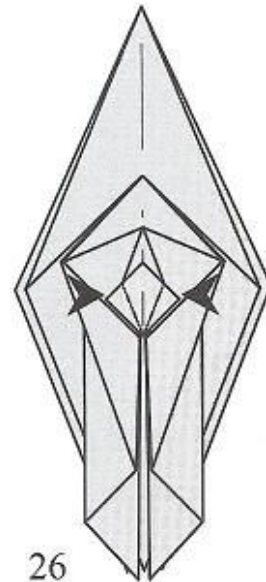

26

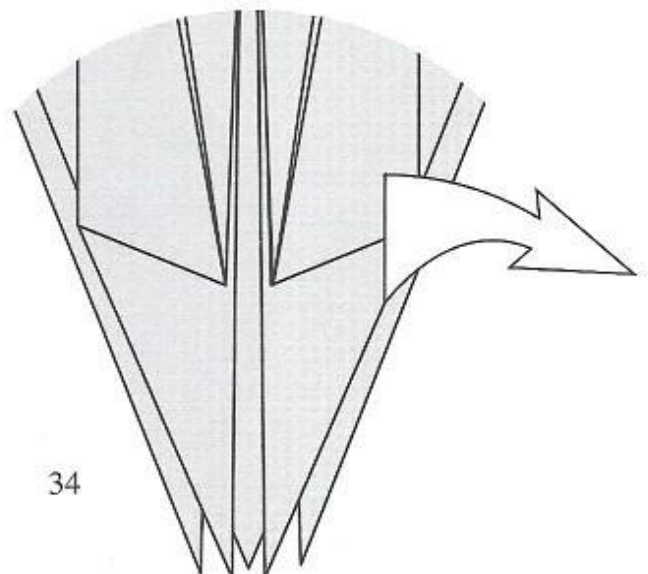
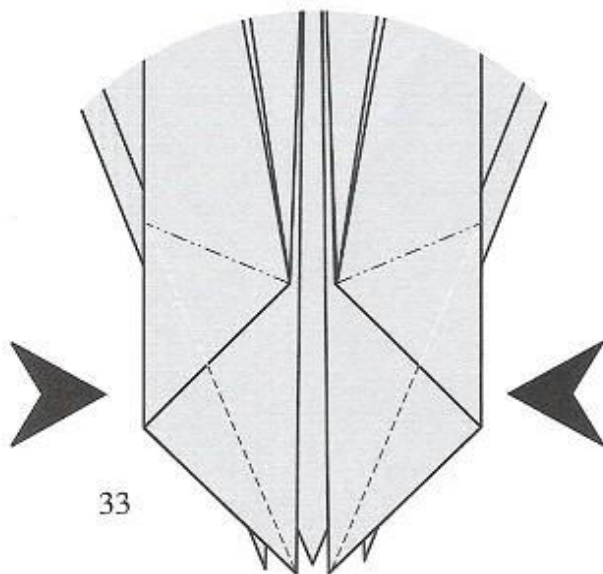
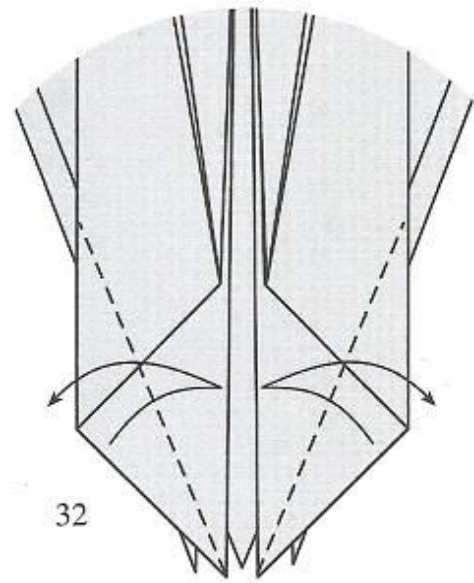
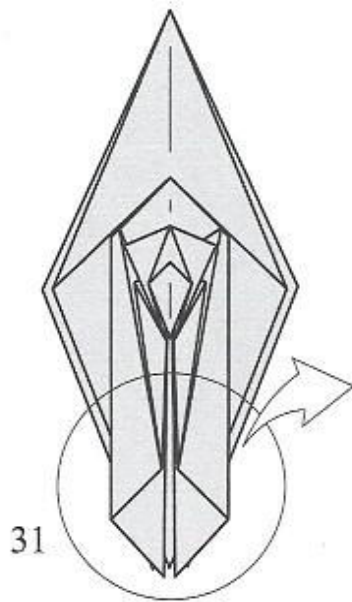
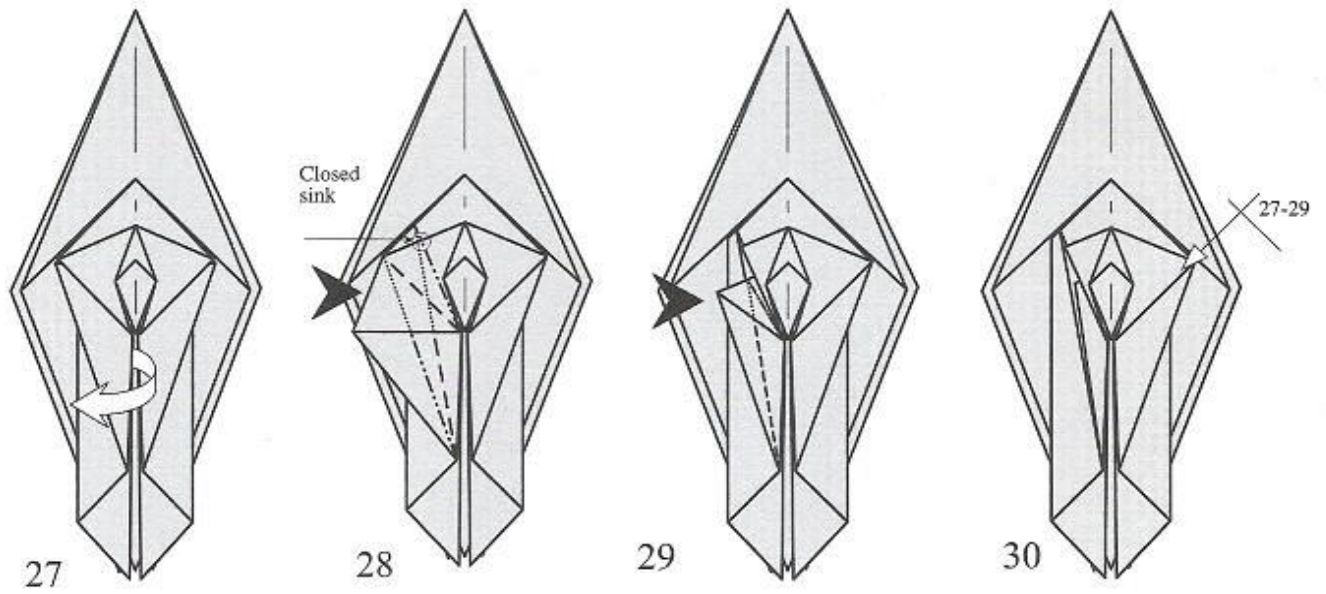

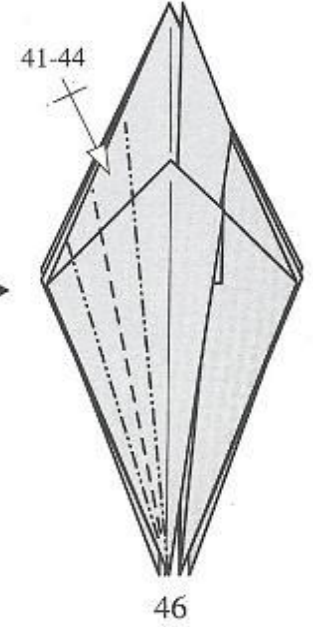
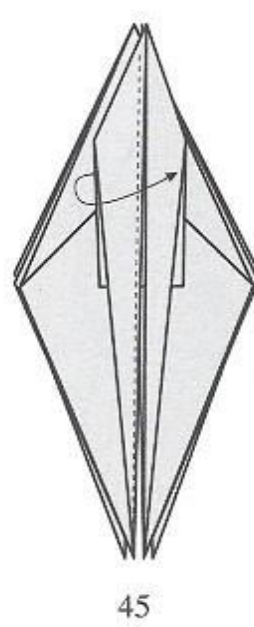
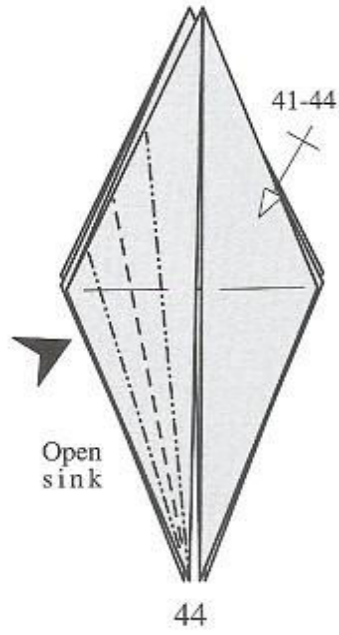
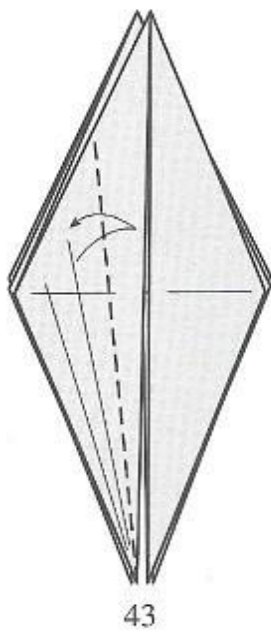
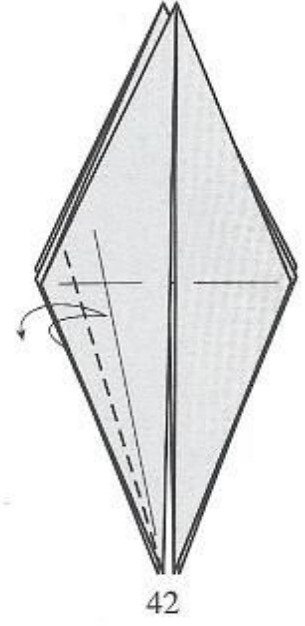
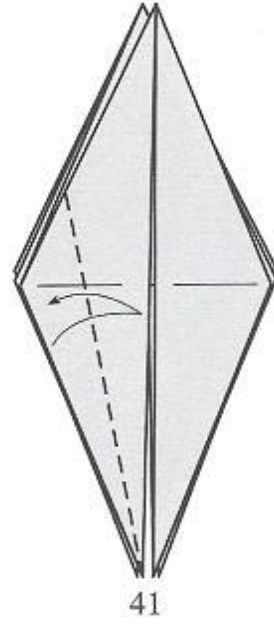
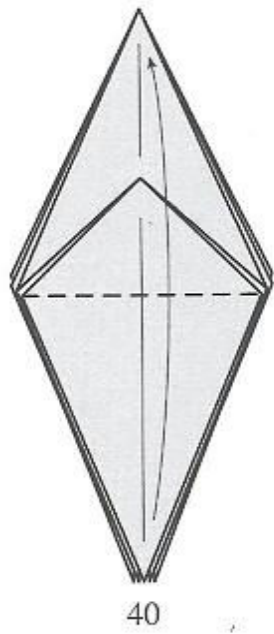
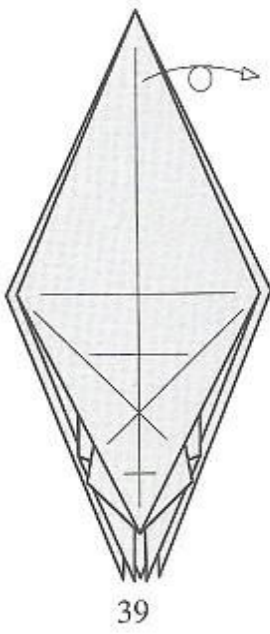
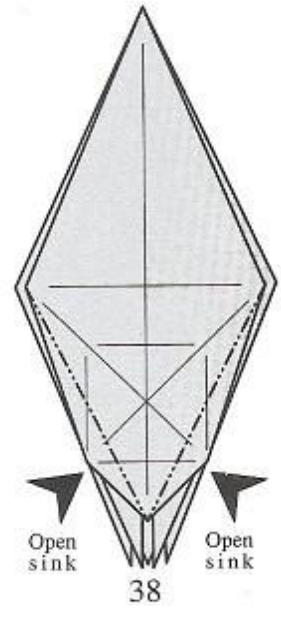
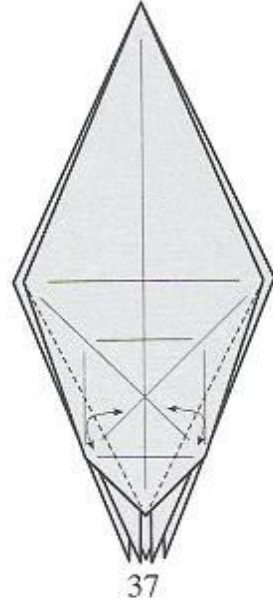
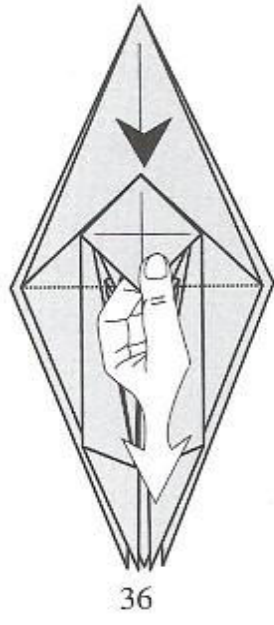
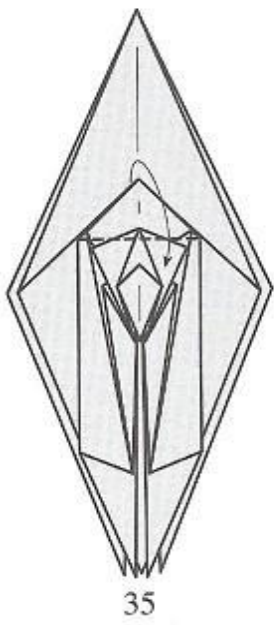

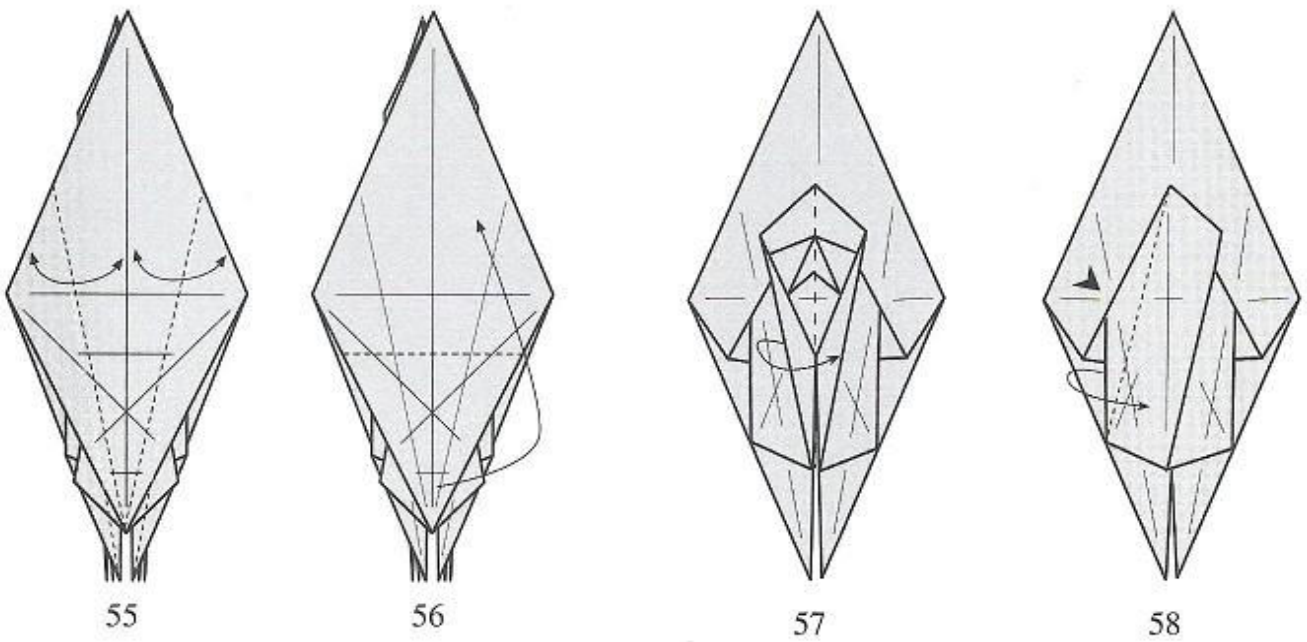
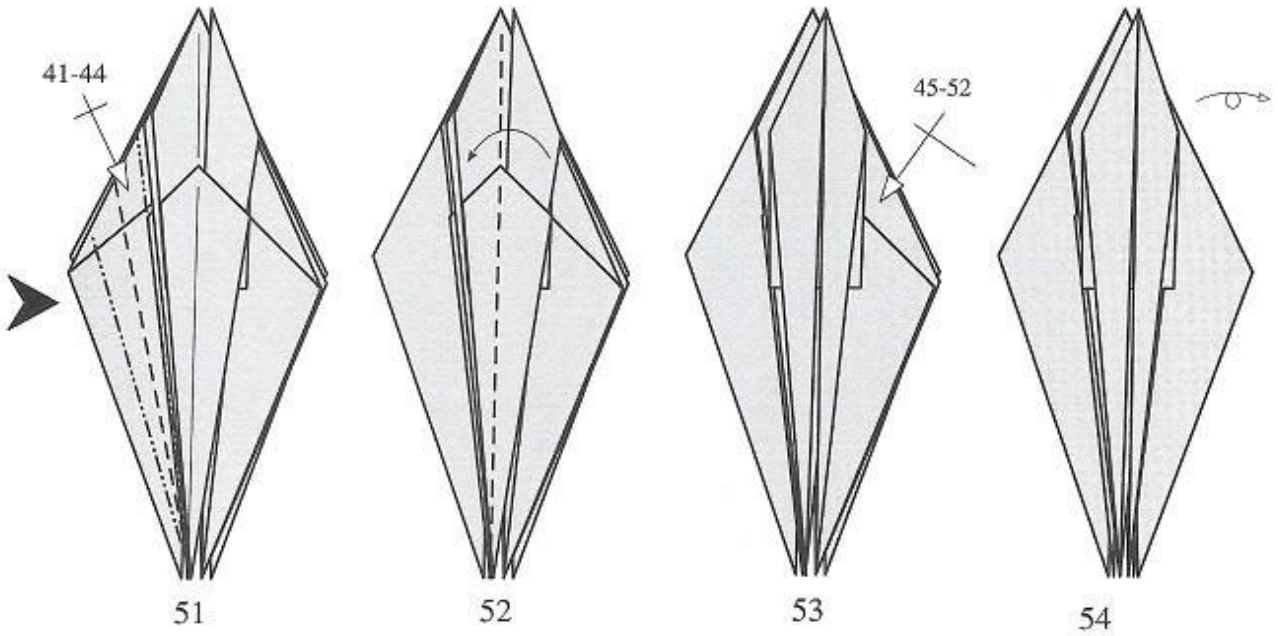
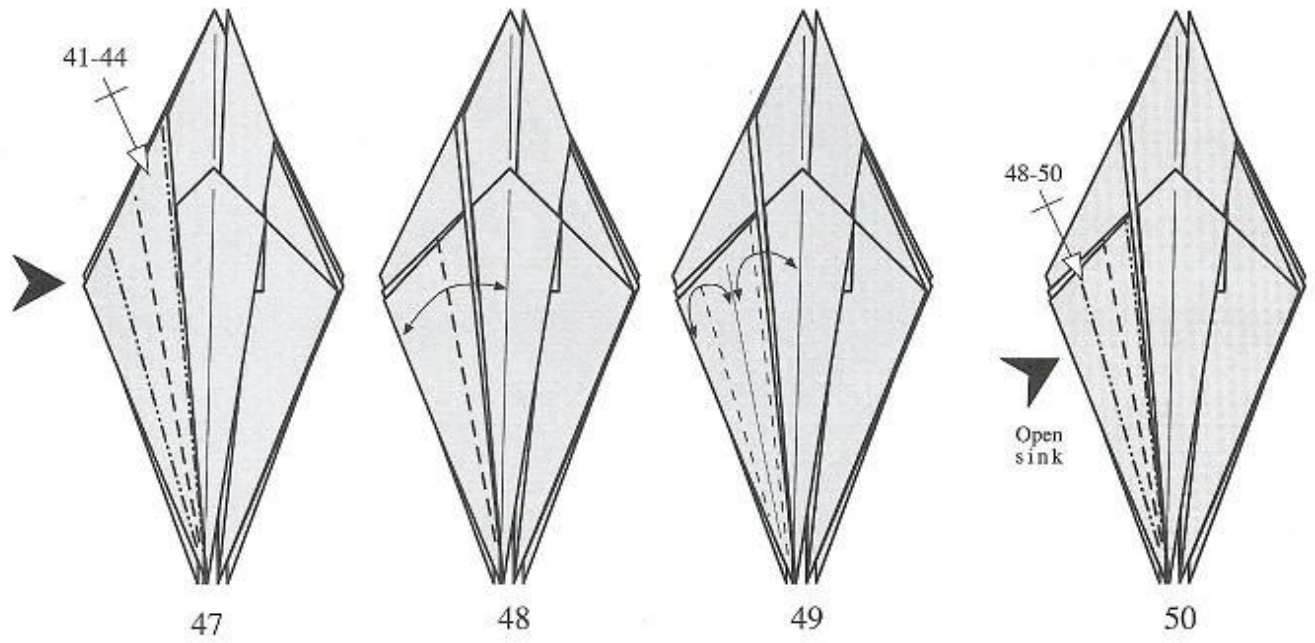

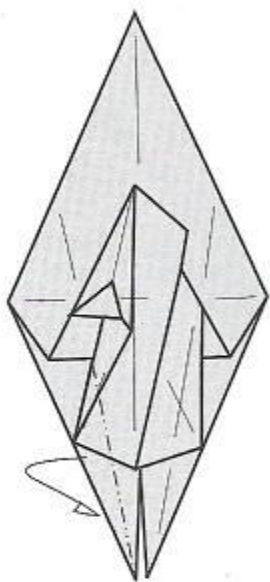

59

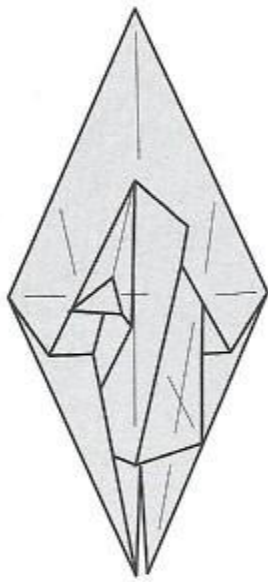

60

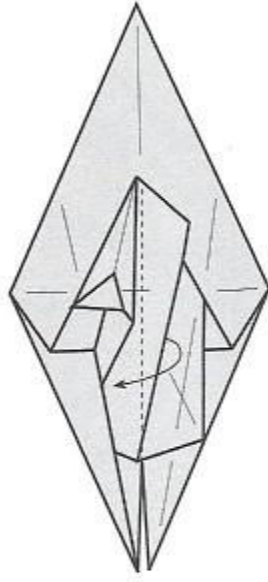

61

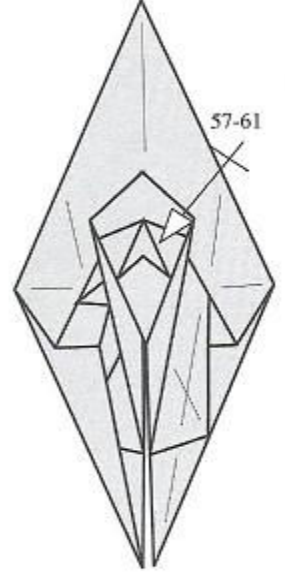

62

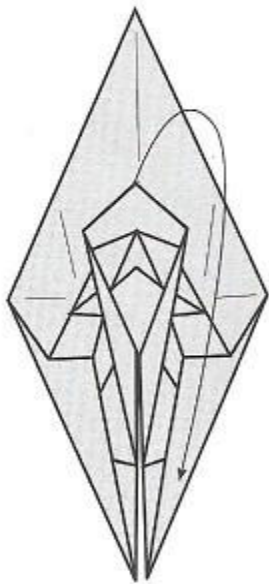

63

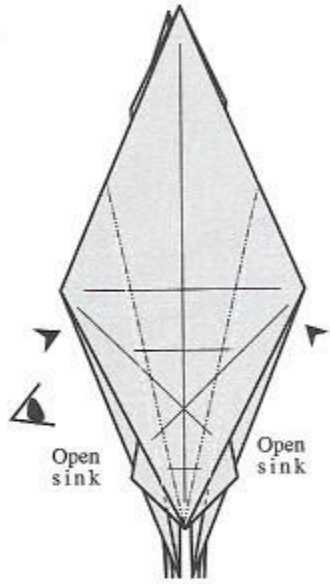

64

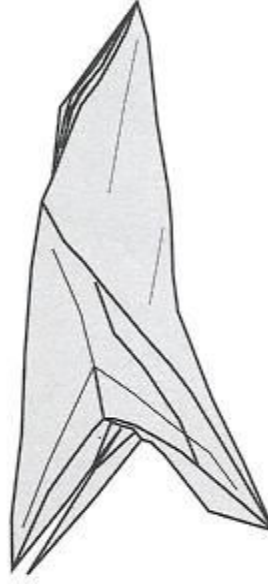

65

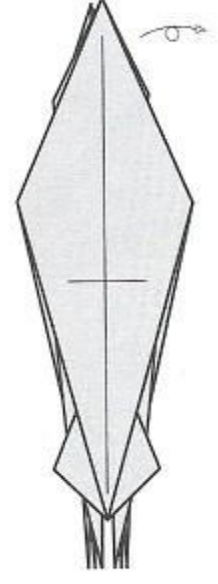

66

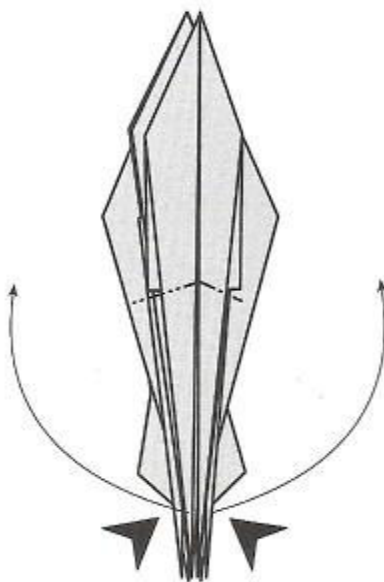

67

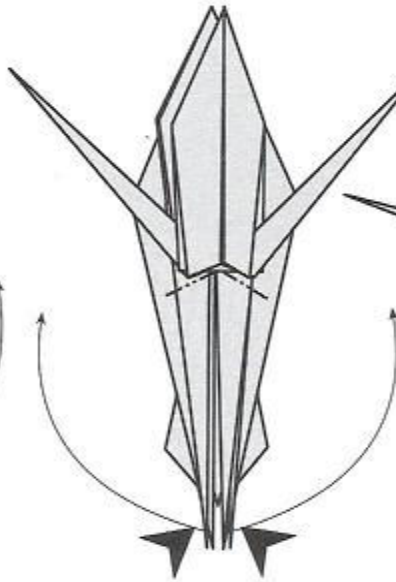

68

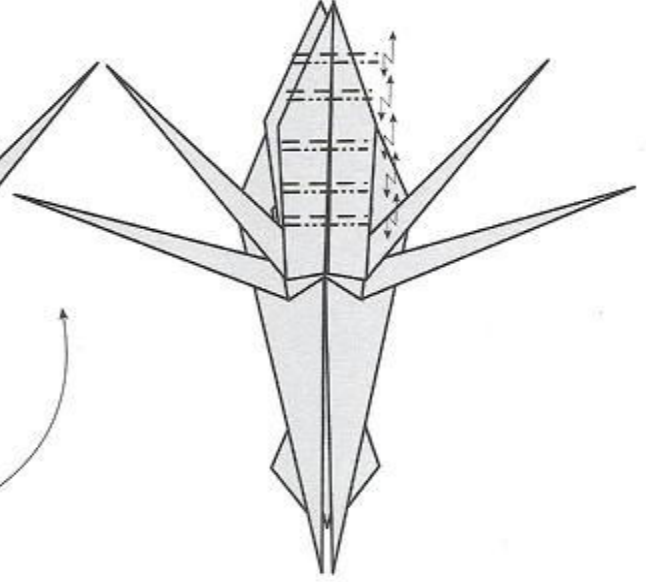

69

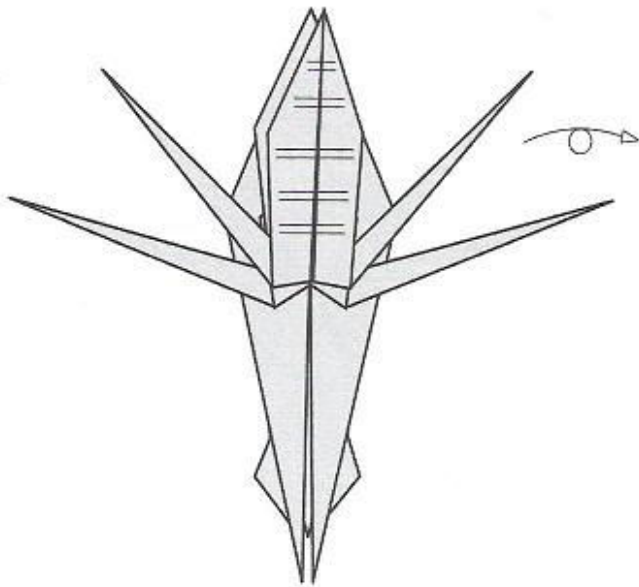

70

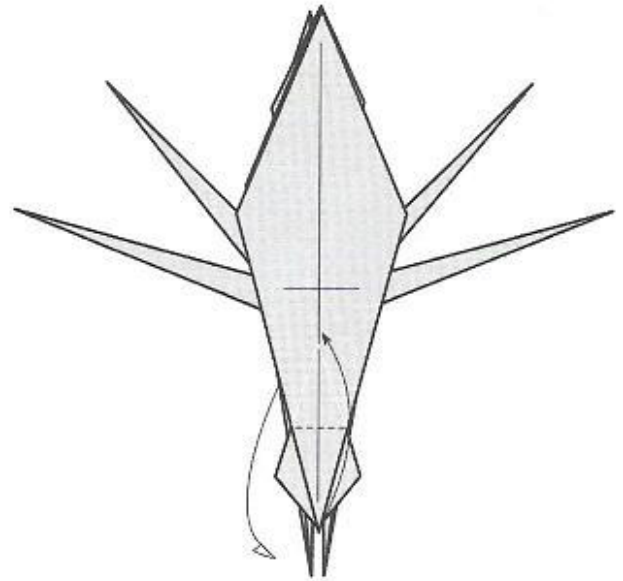

71

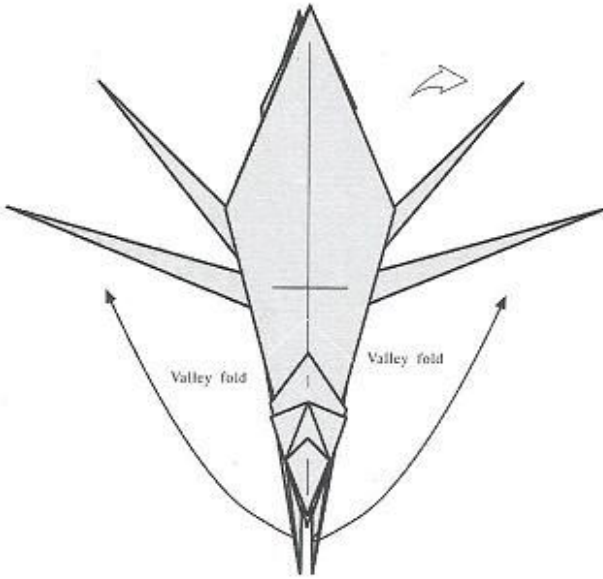

72

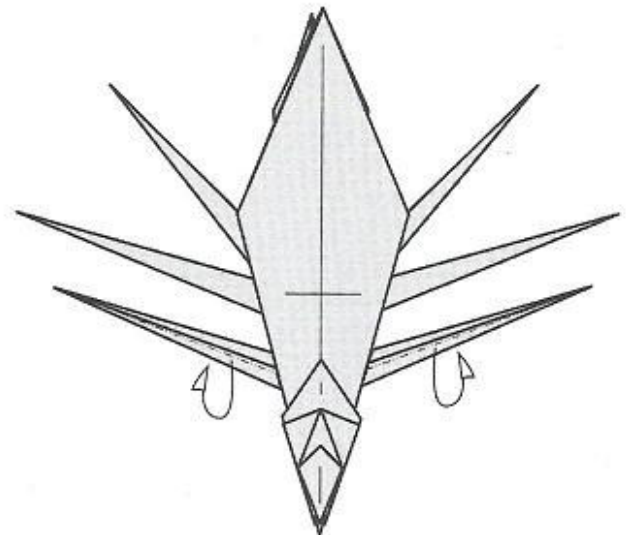

73

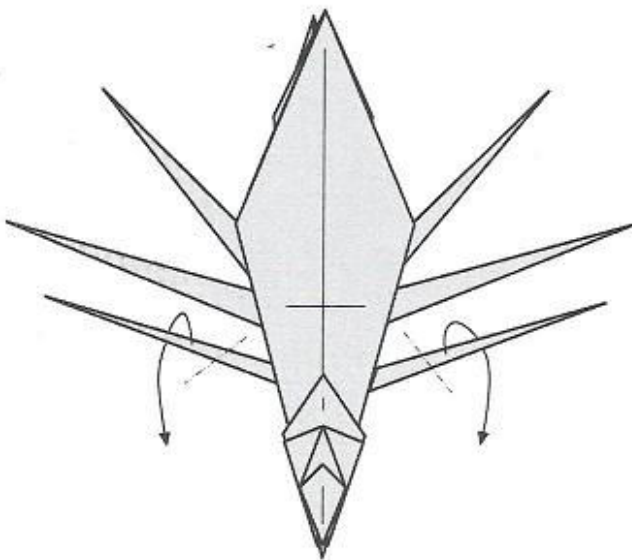

74

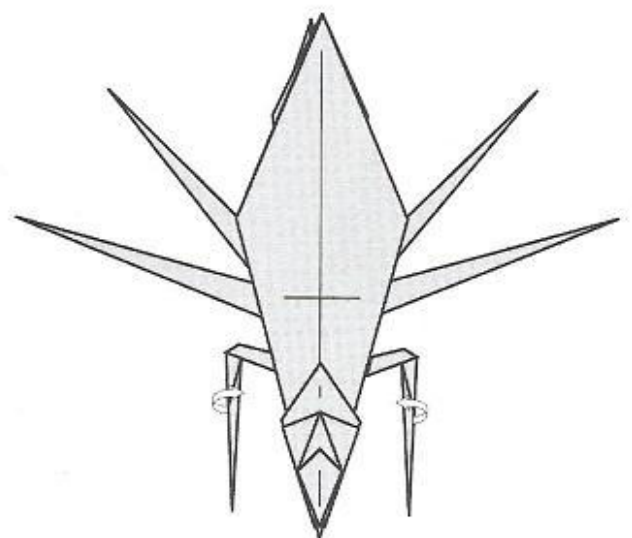

75

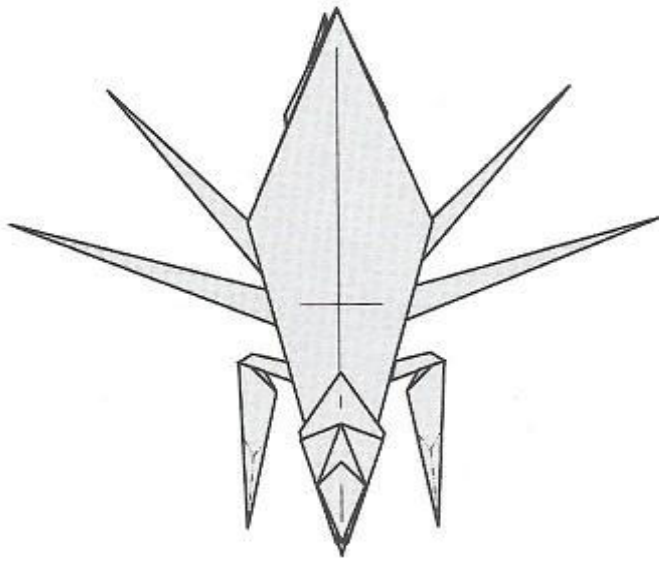

76

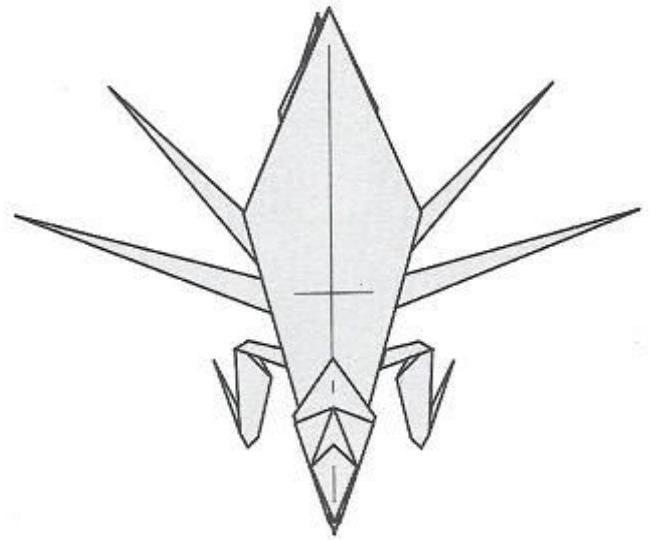

77

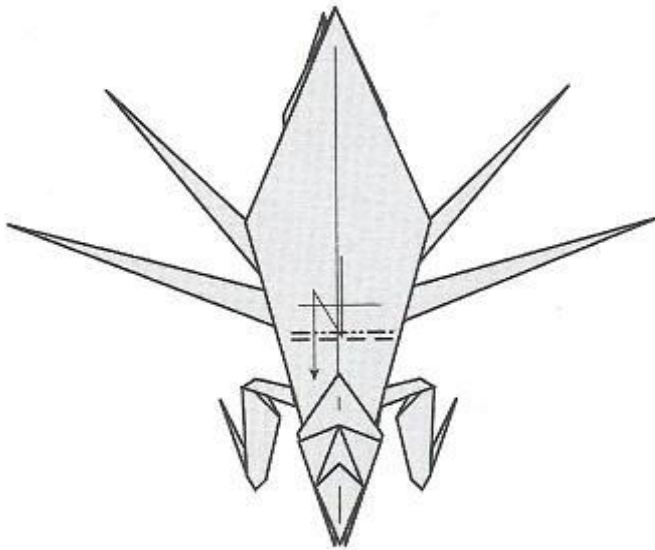

78

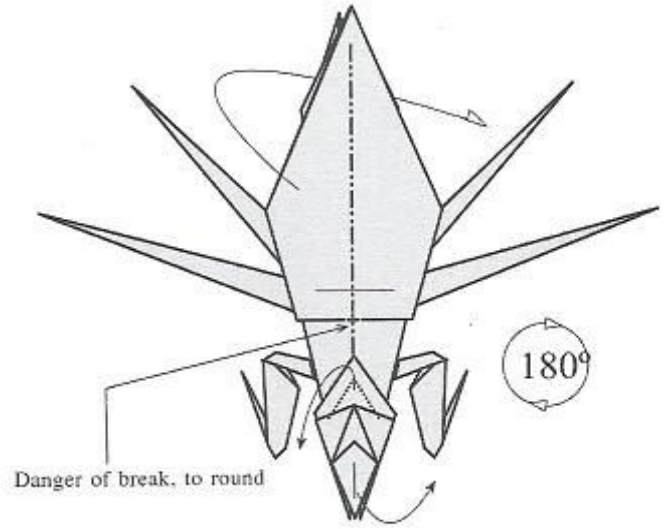

Danger of break, to round

180°

79

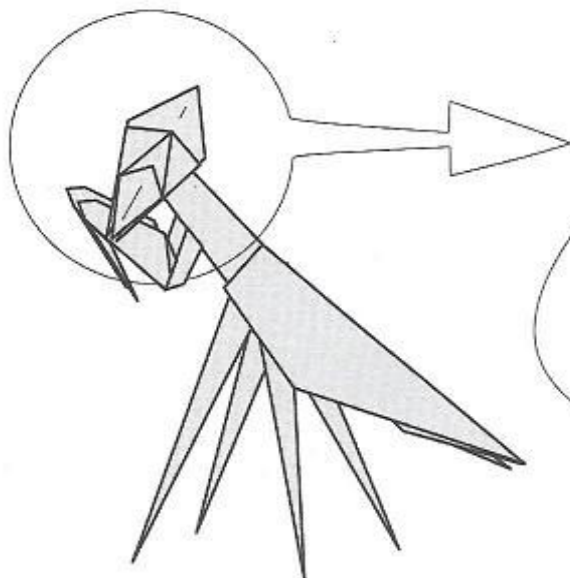

80

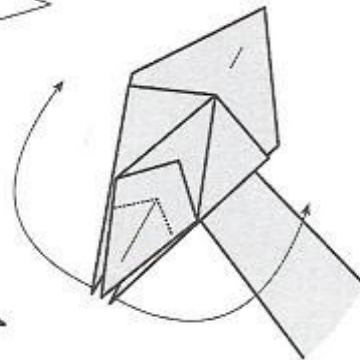

81

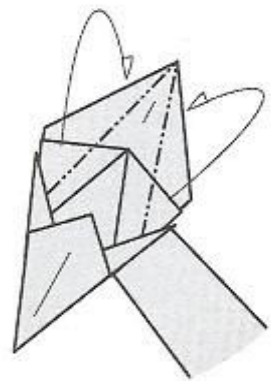

82

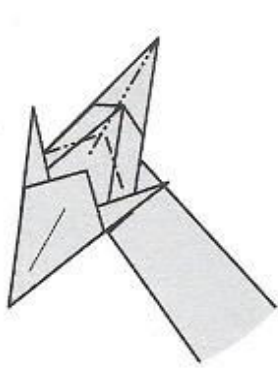

83

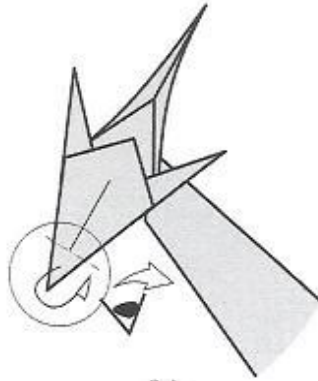

84

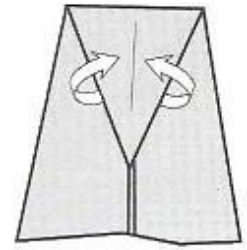

bottom view

85

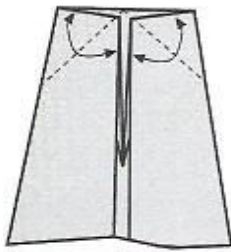

86

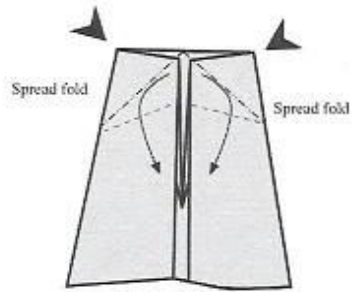

87

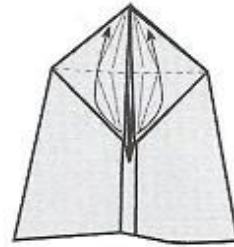

88



89

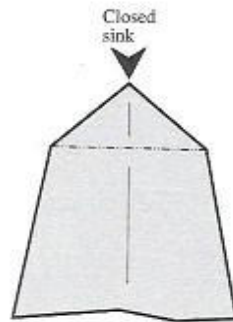

90



91

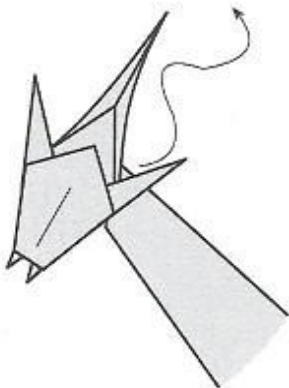

92

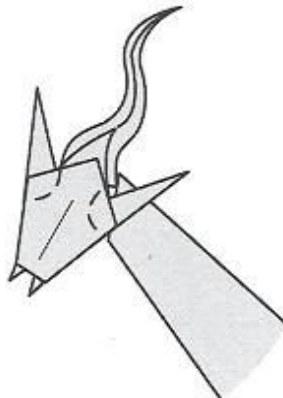

93

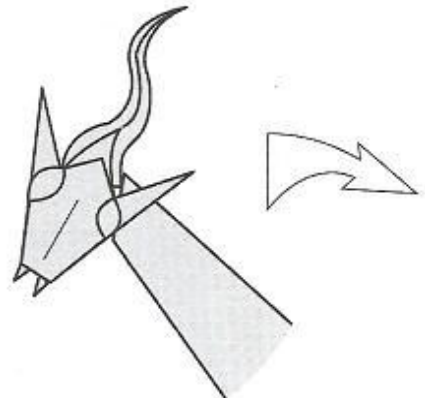

94

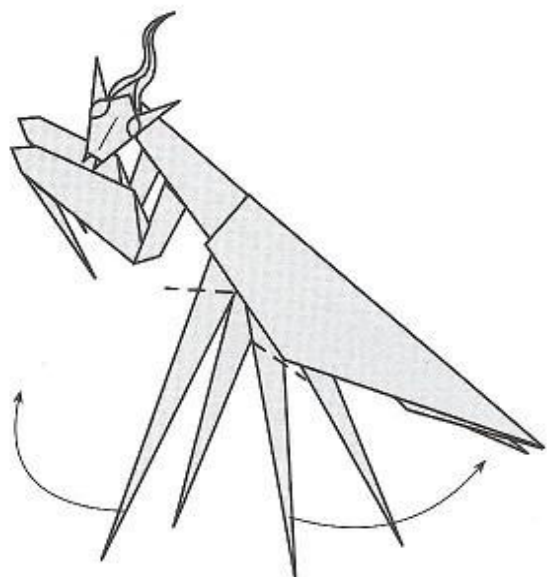

95

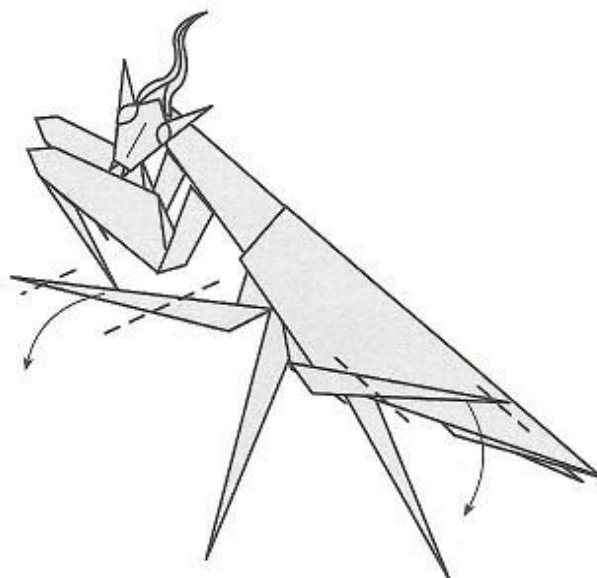

96

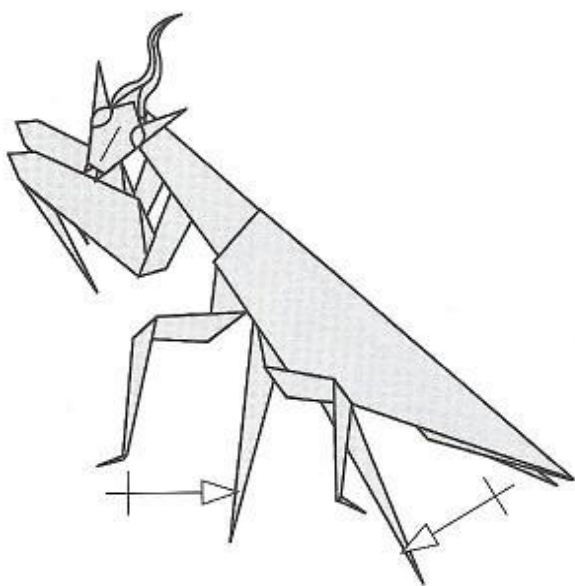

97

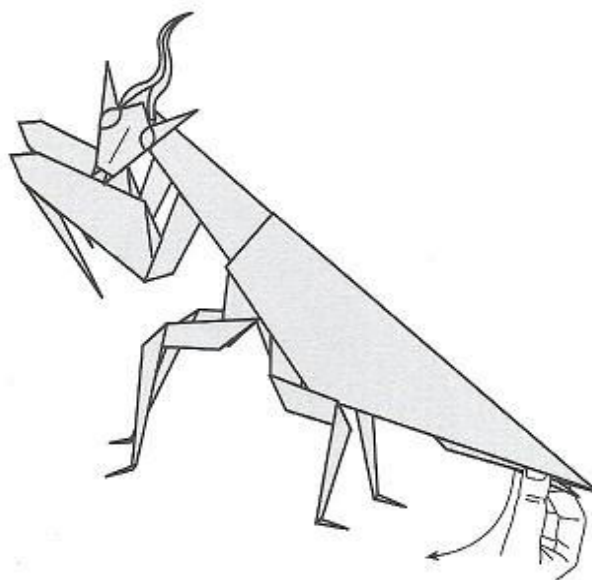

98

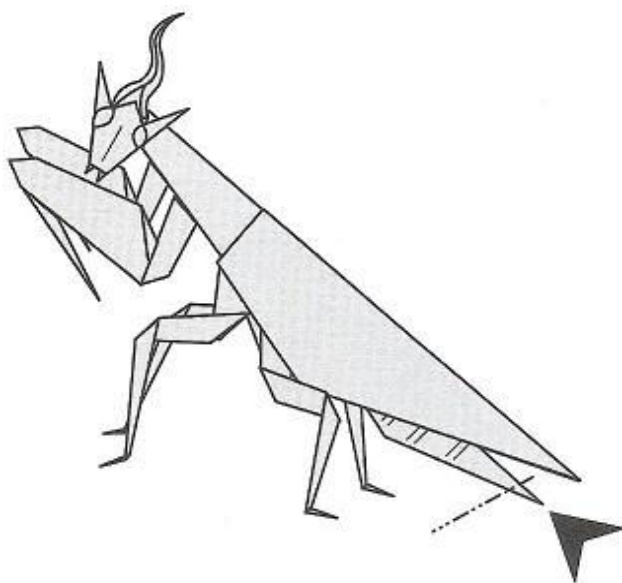

99

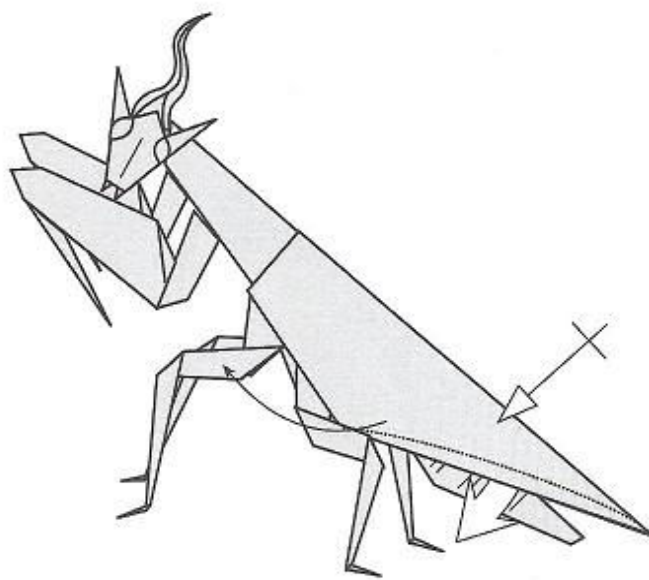

100

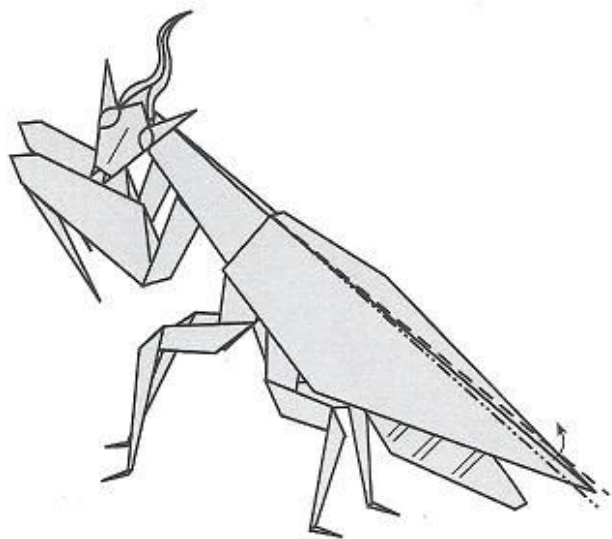

101

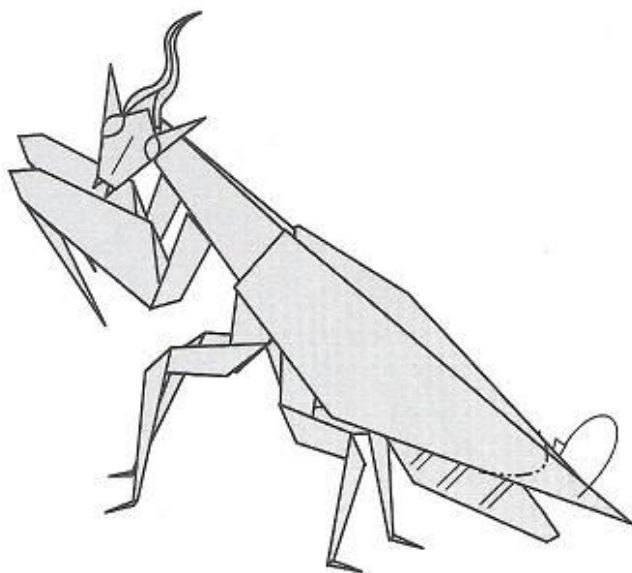

102

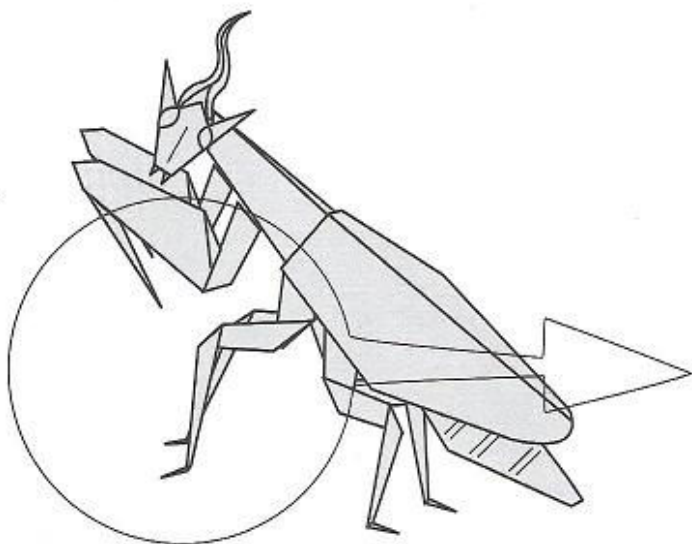

103

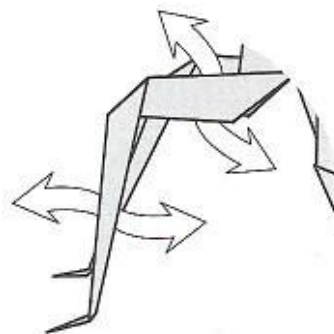

104

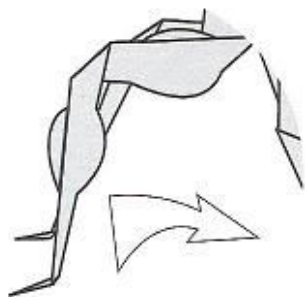

105

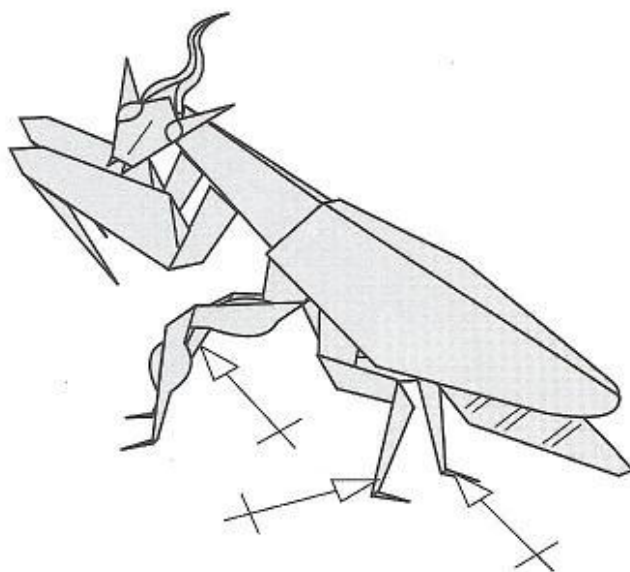

106

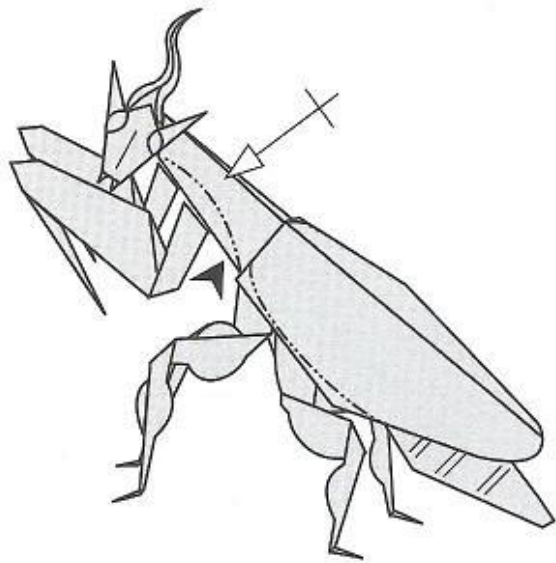

107

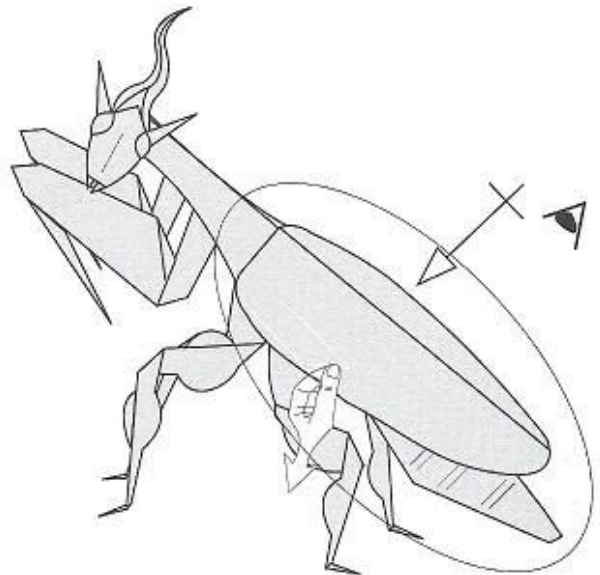

108

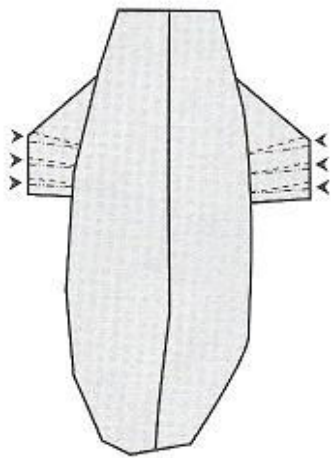

109

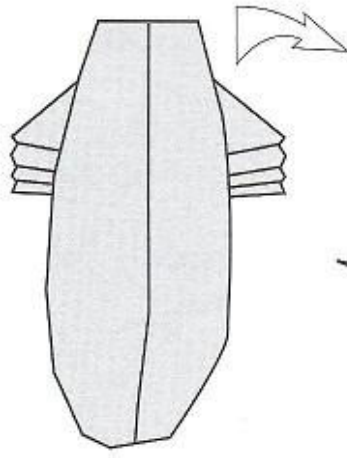

110

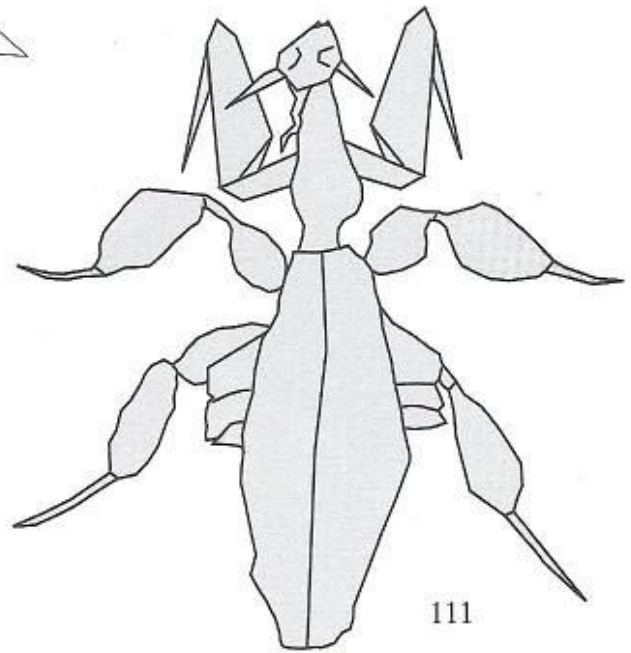

111

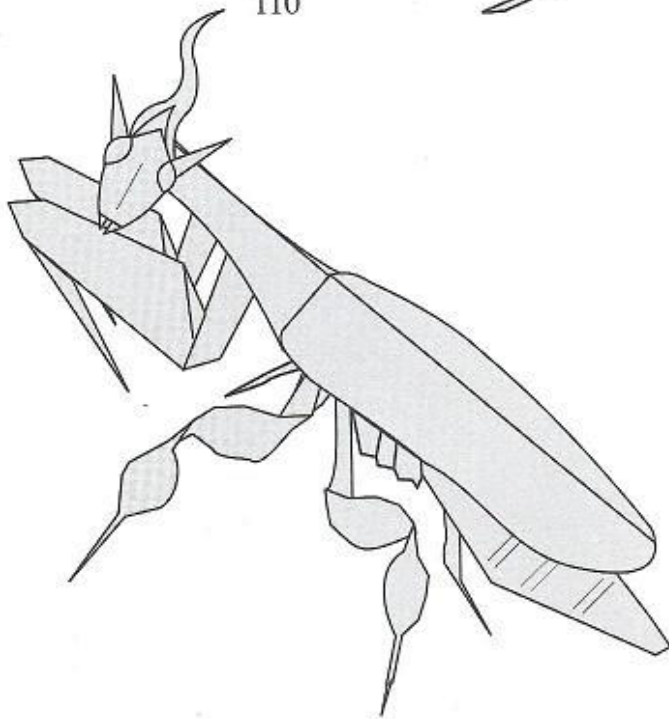

112

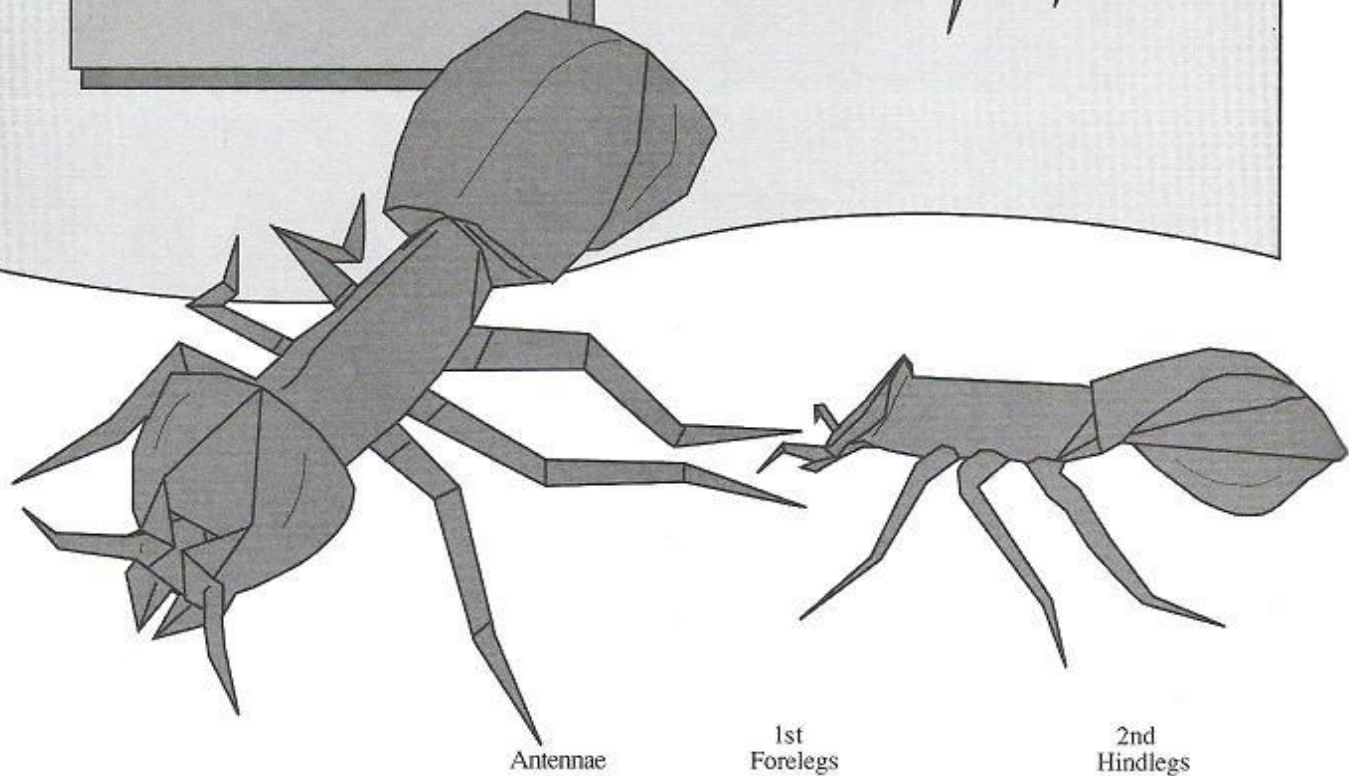
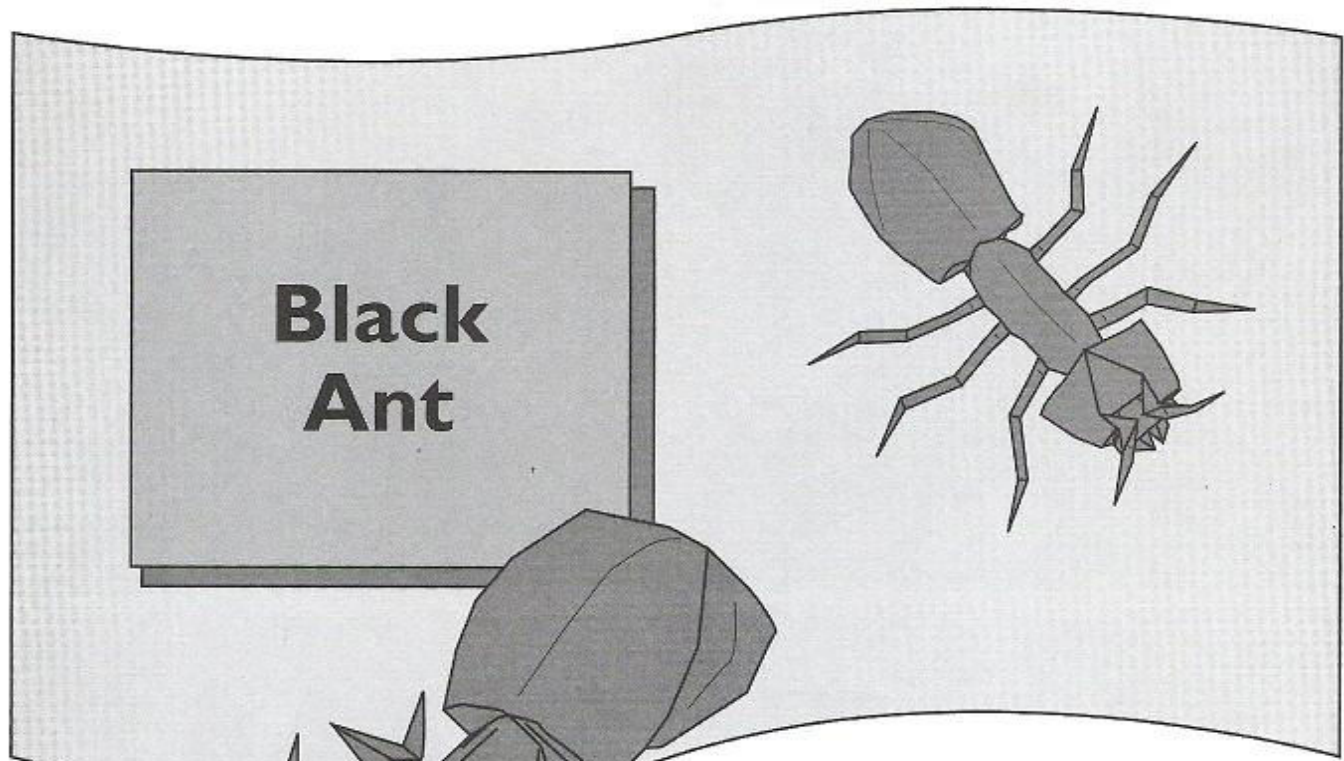

The paper should be black. Fine paper is recommended, less than 40 grams, double silk, banana tree, lokta, metallic or "sandwich," 9.8x9.8 inches (25x25 cm) or bigger.

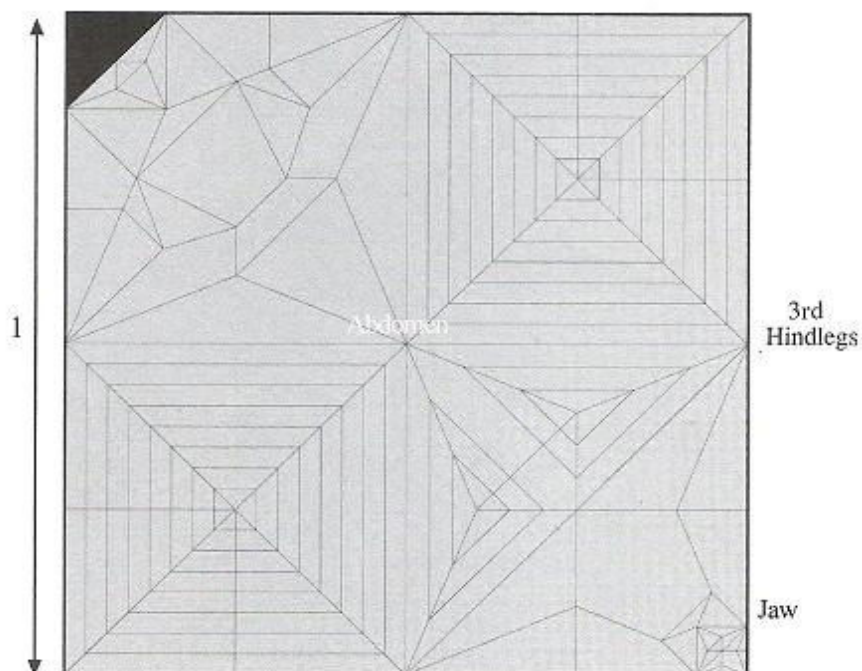
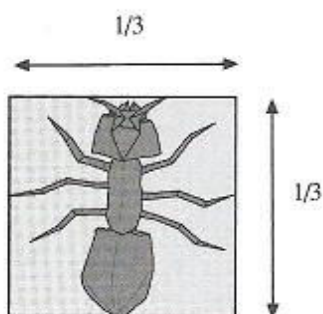

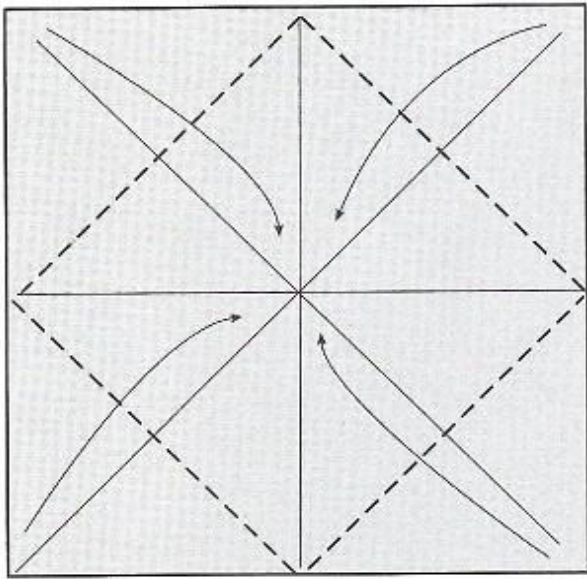

1

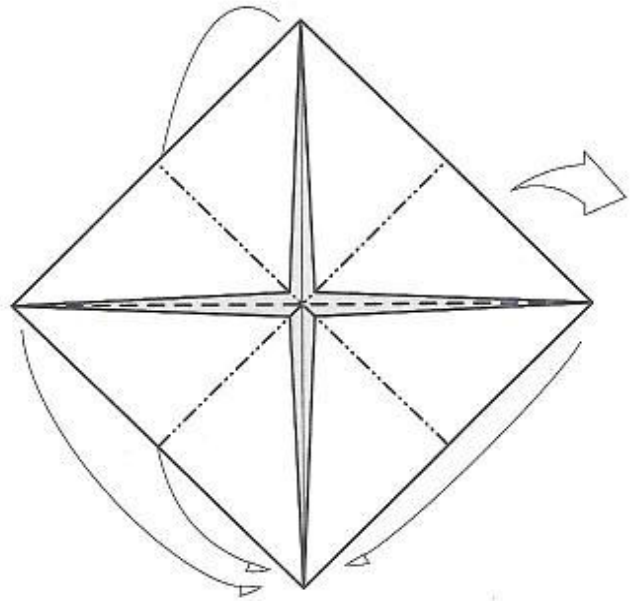

2

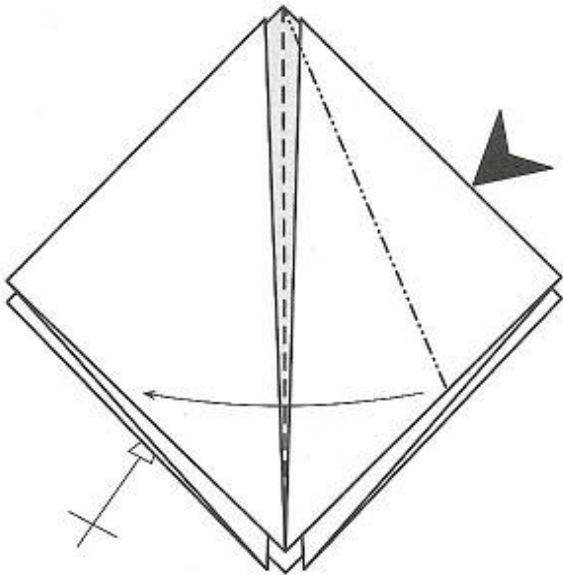

3

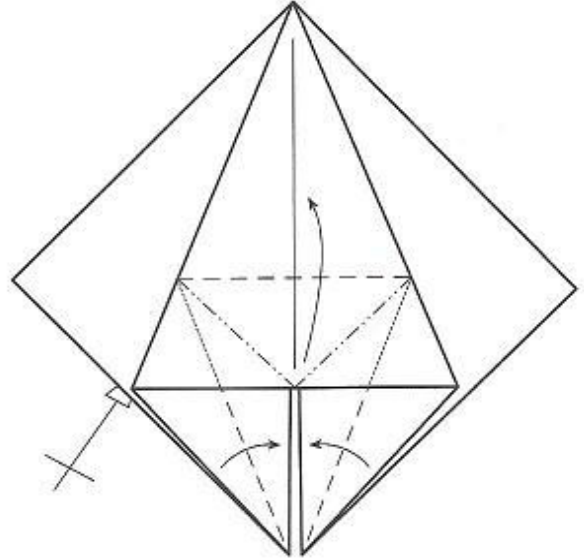

4

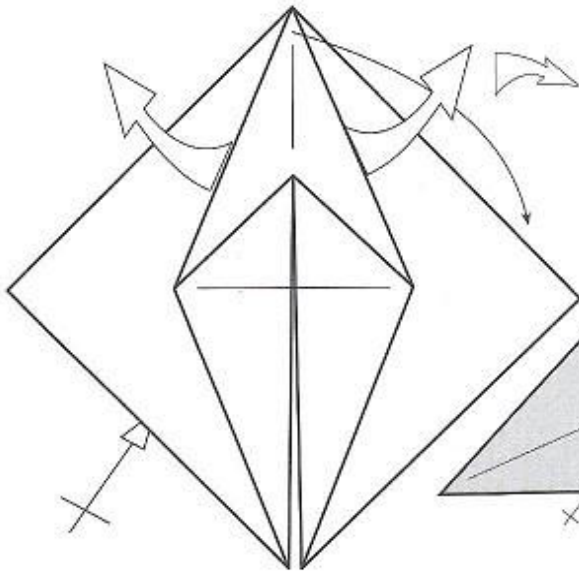

5

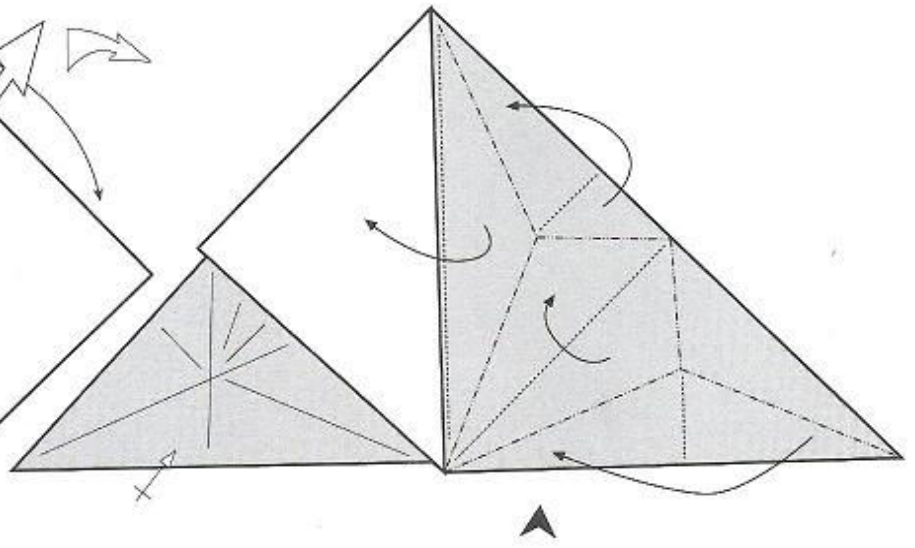

6

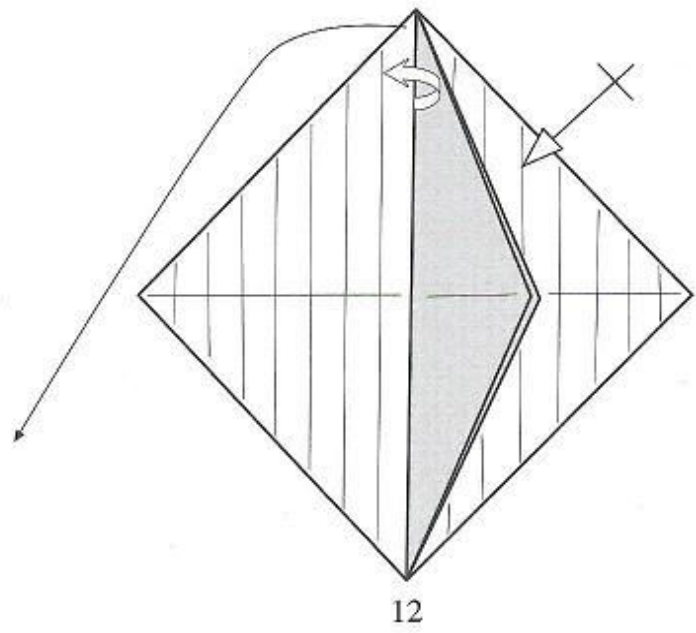
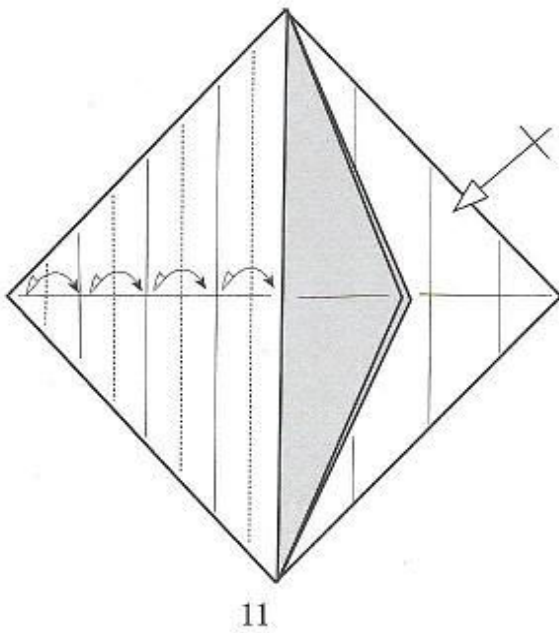
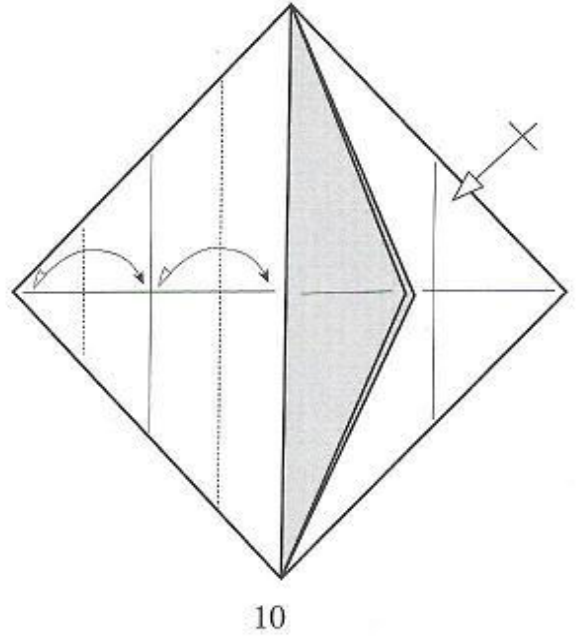
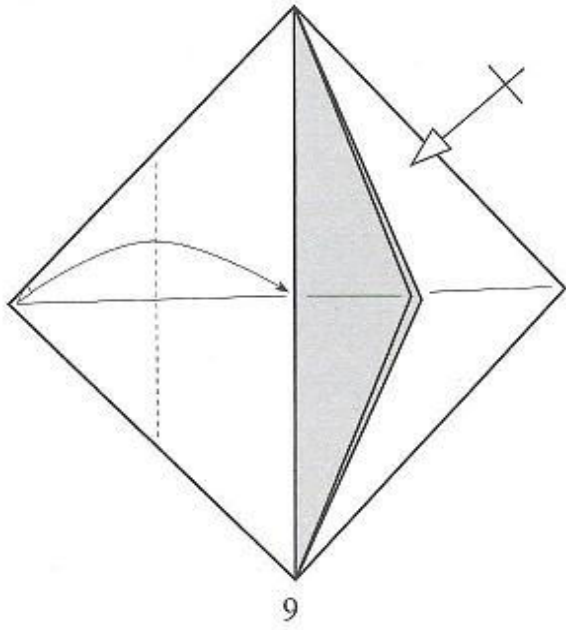
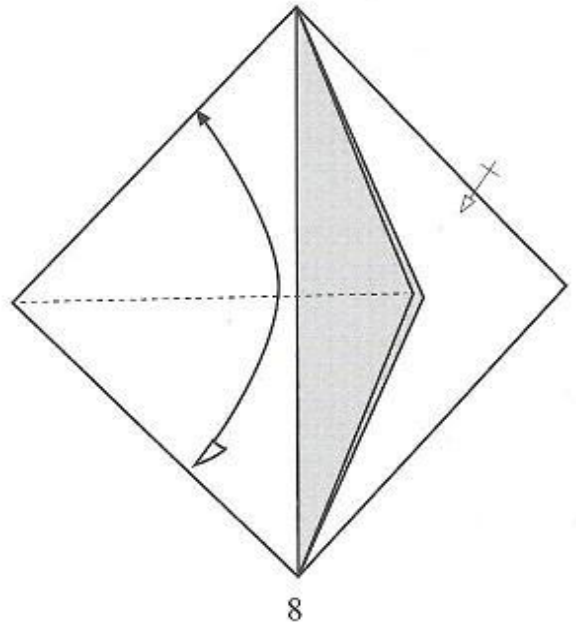
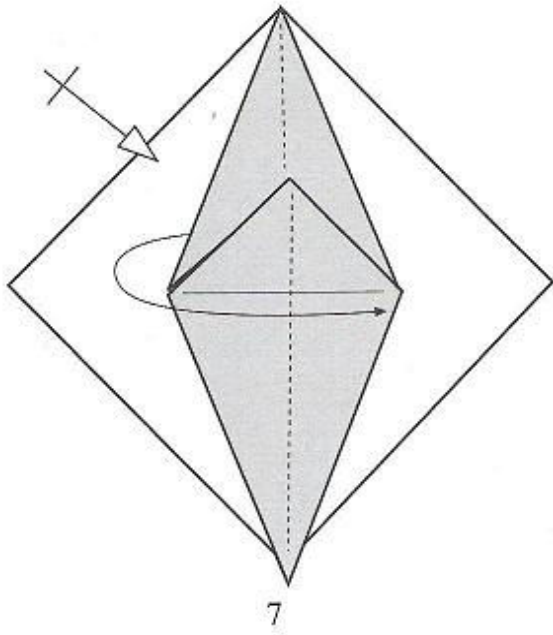

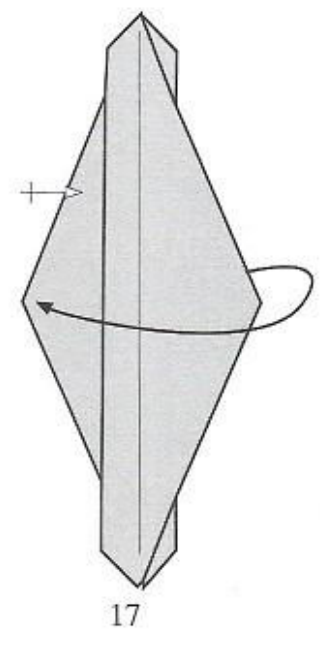
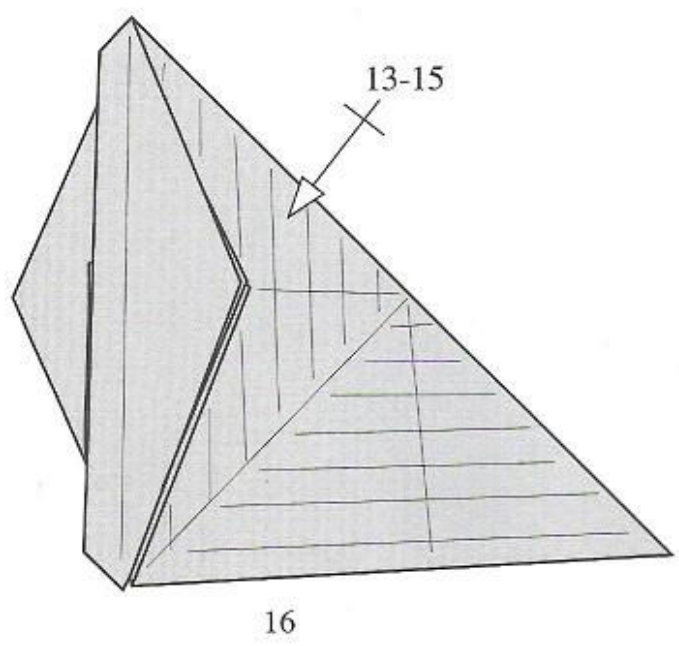
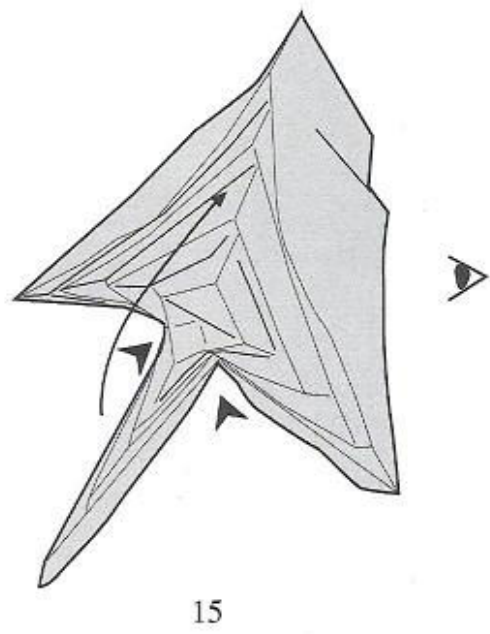
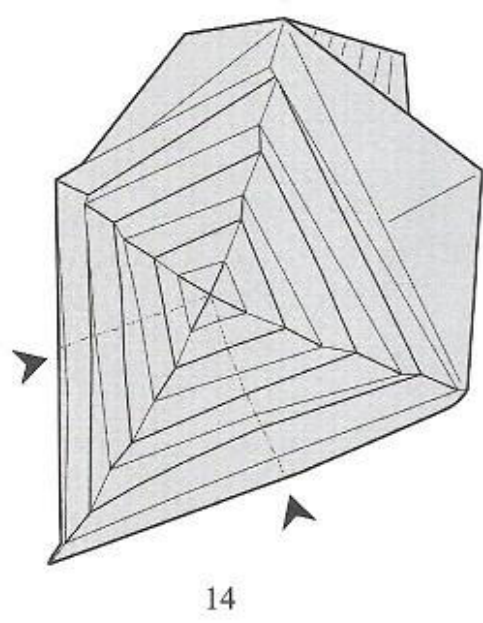
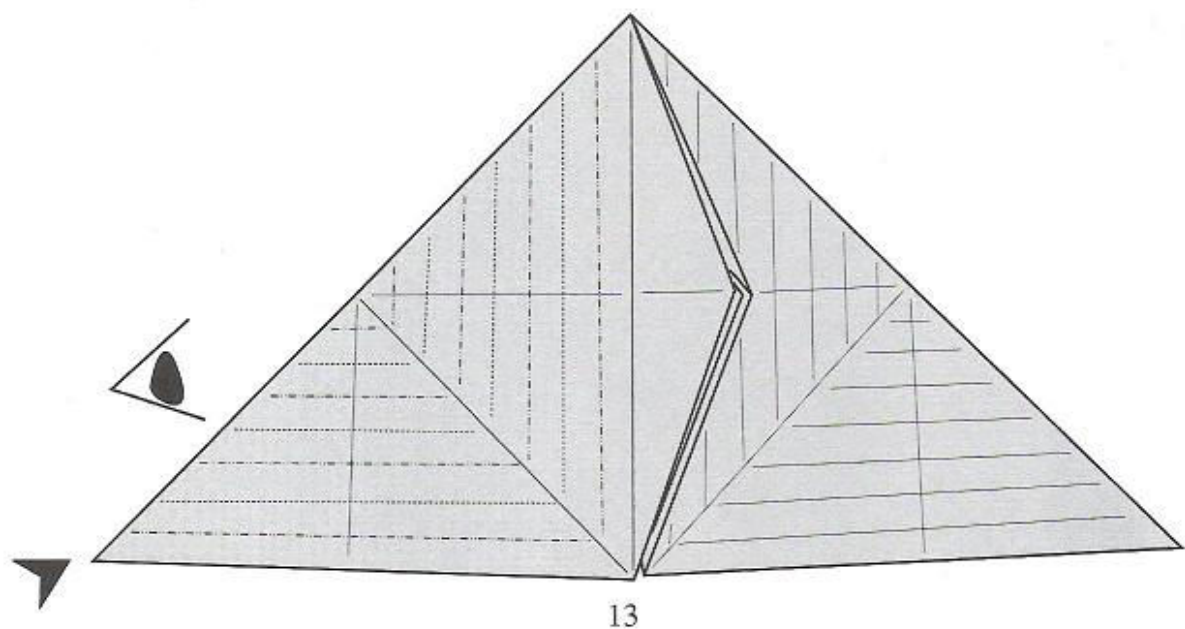

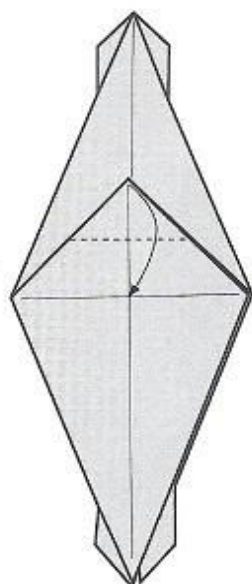

18

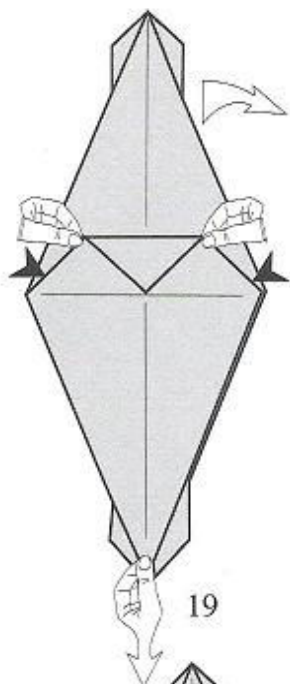

19

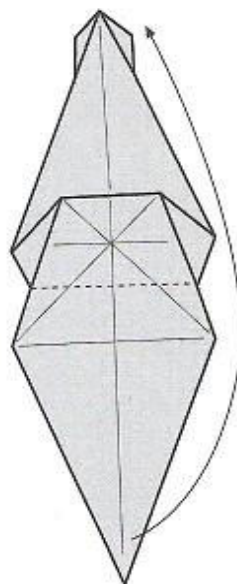

20

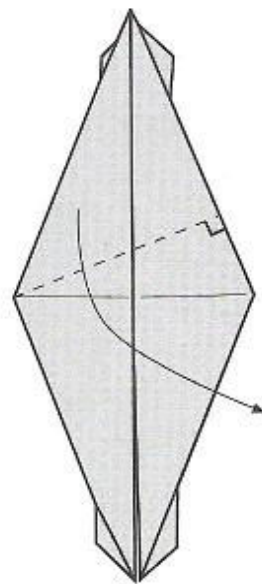

21

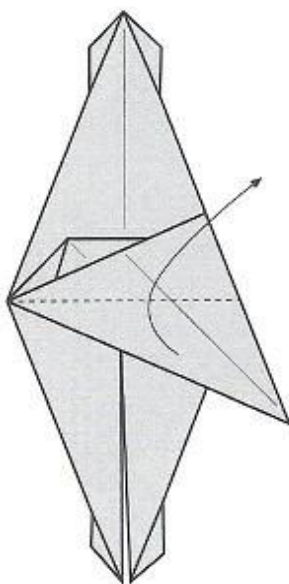

22

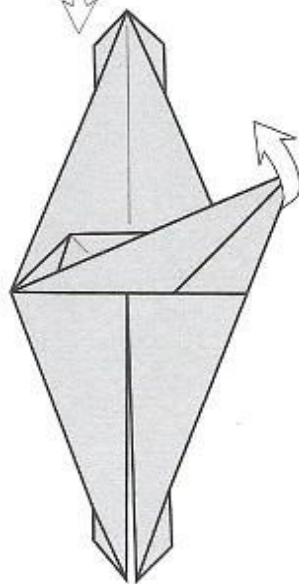

23

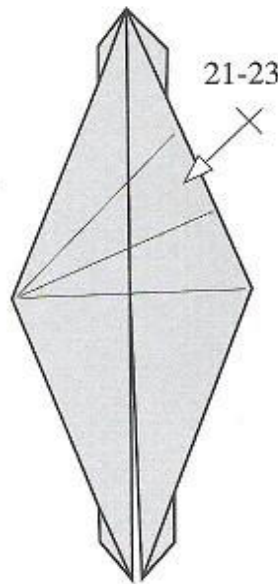

24

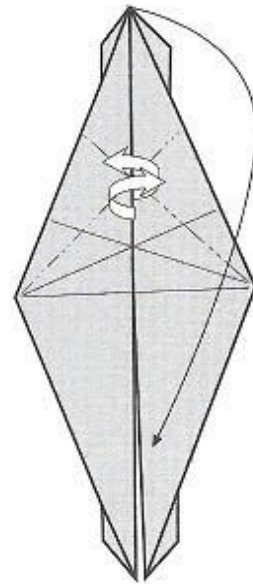

25

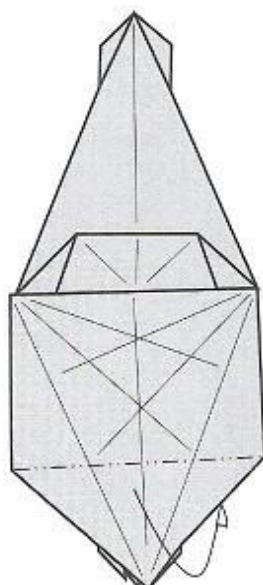

26

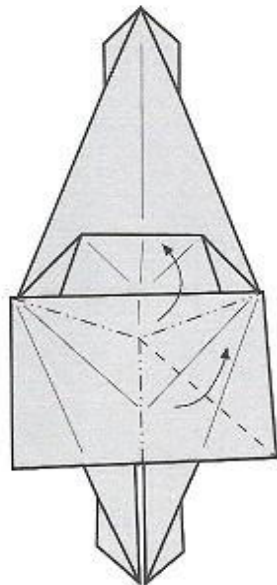

27

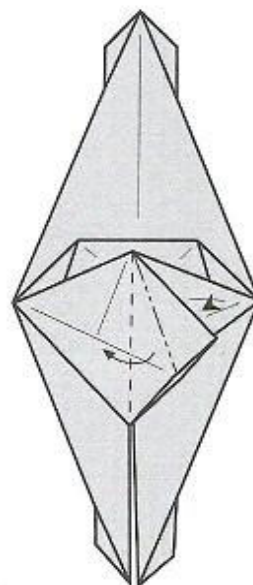

28

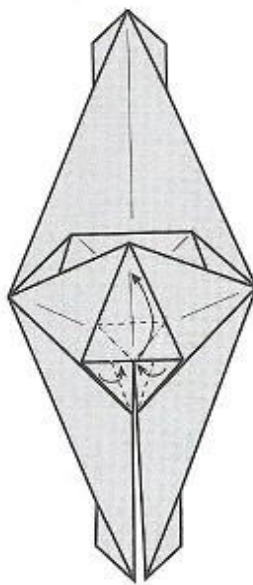

29

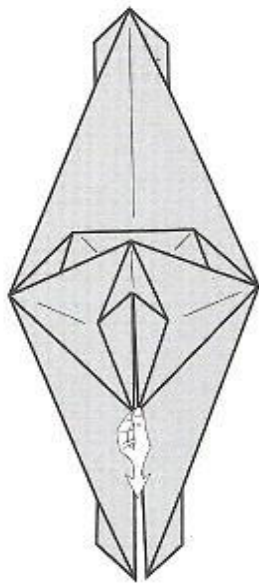

30

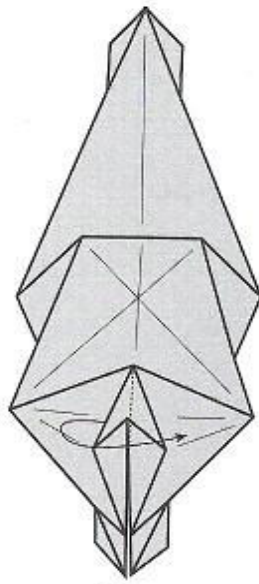

31

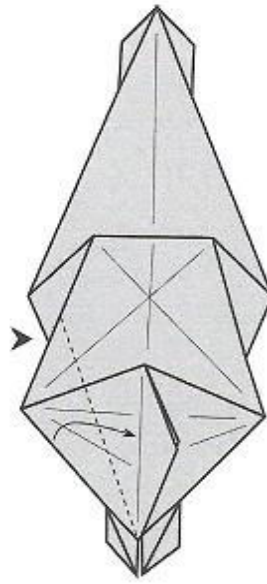

32

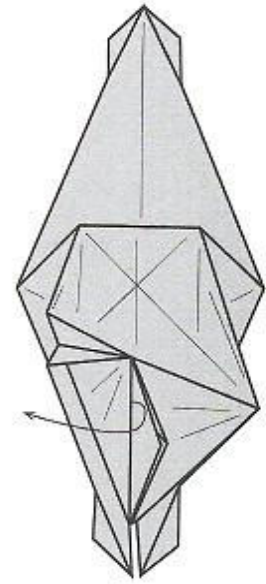

33

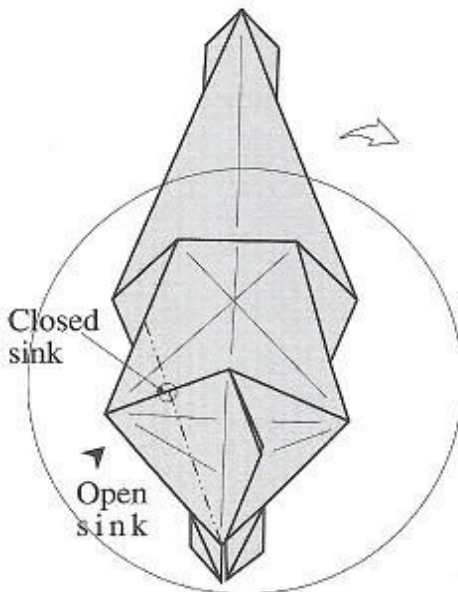

34

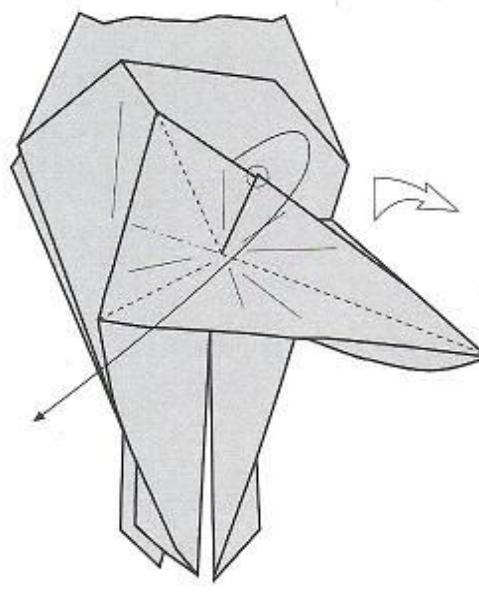

35

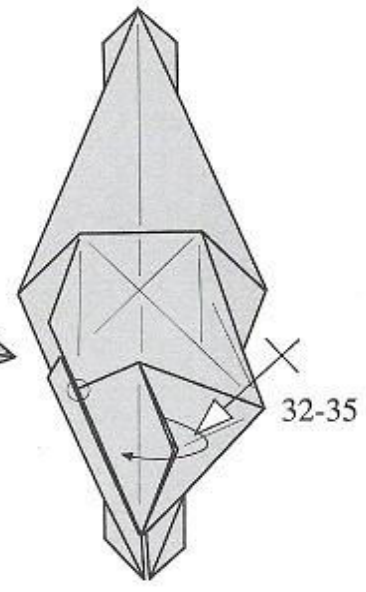

36

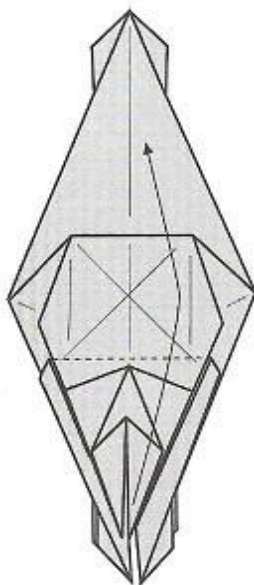

37

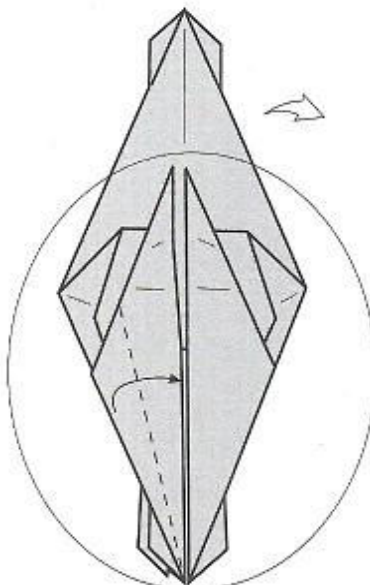

38

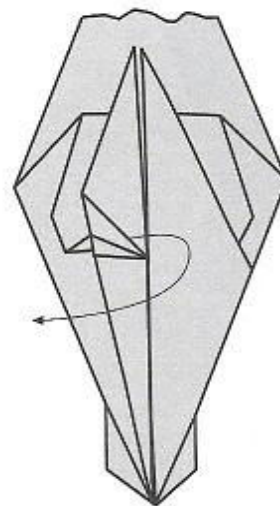

39

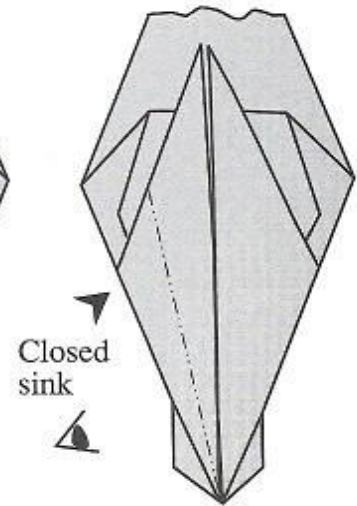

40

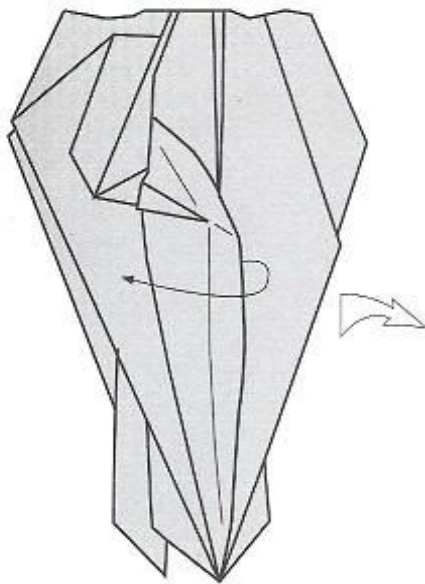

41

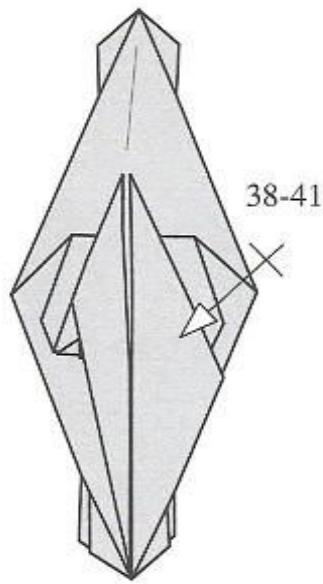

38-41

42

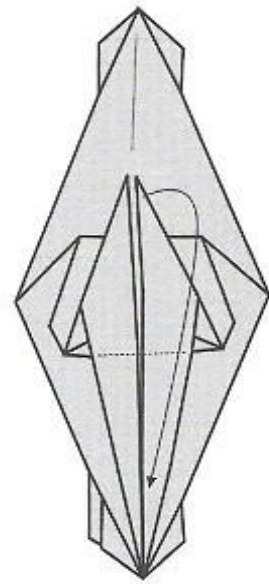

43

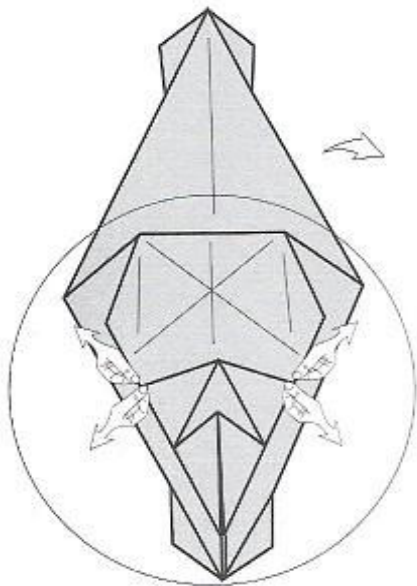

44

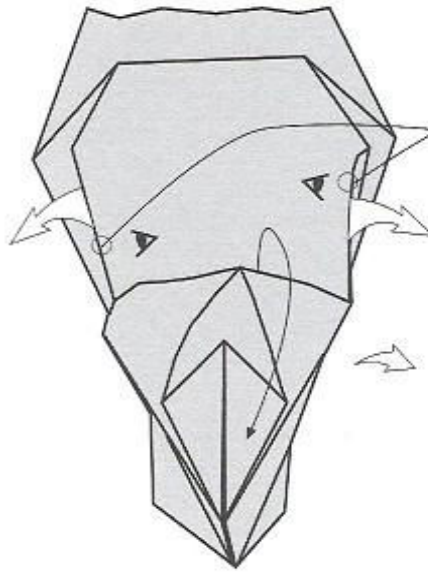

45

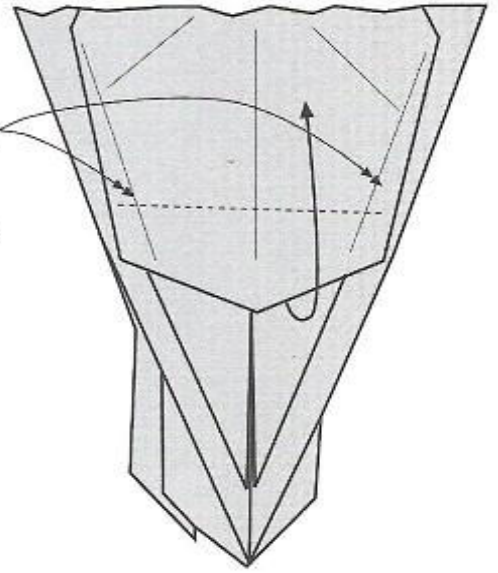

46

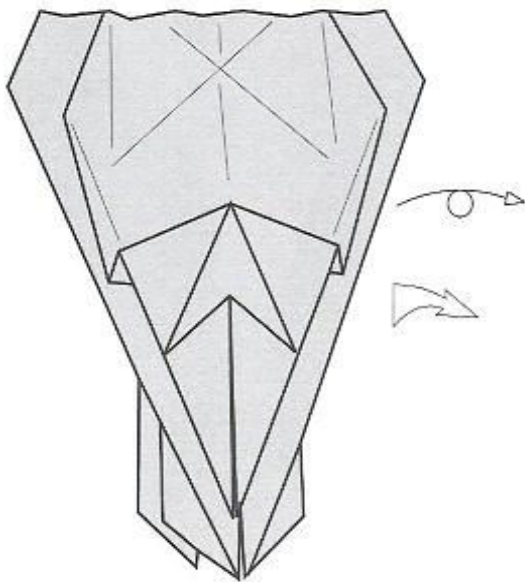

47

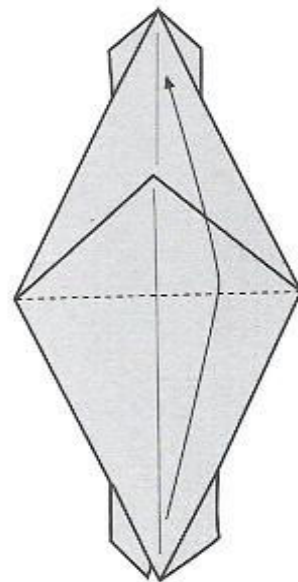

48

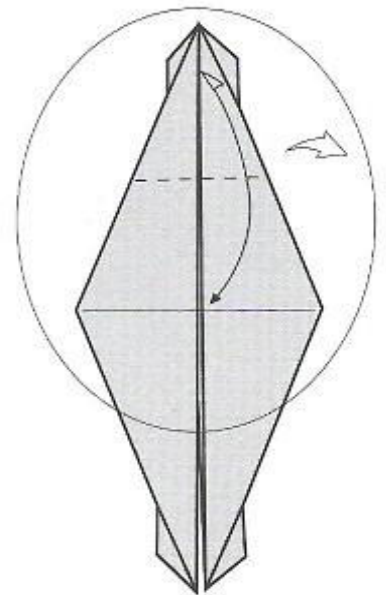

49

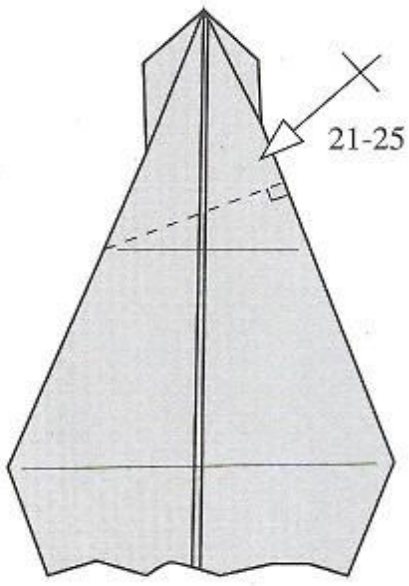

50

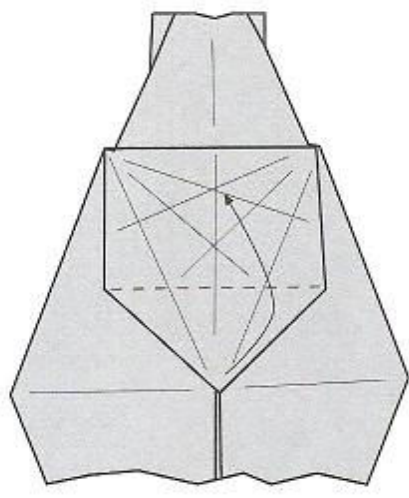

51

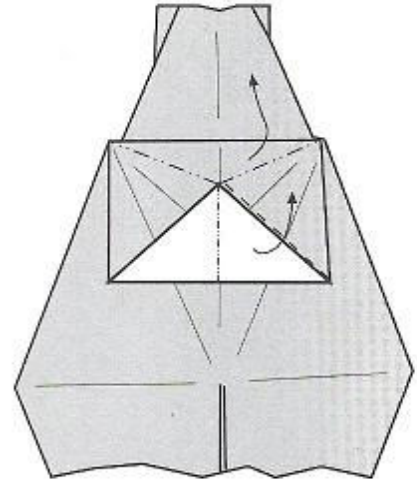

52

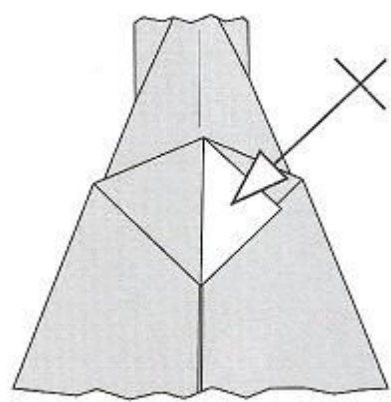

53

3-6
Only this face

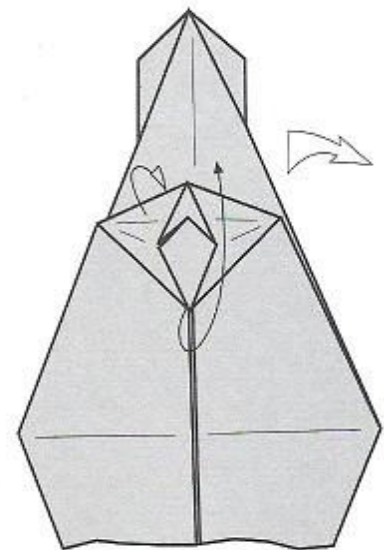

54

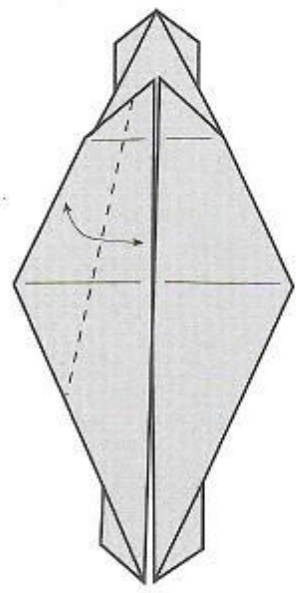

55

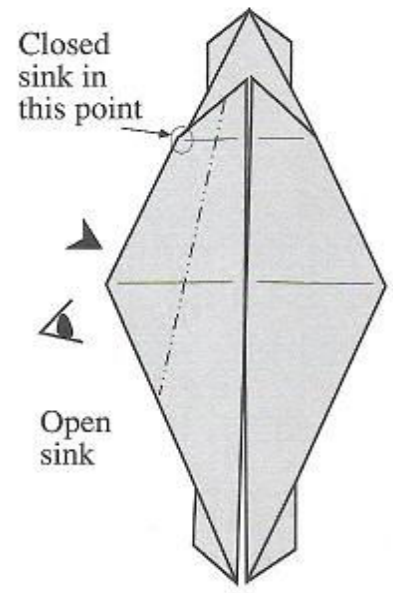

56

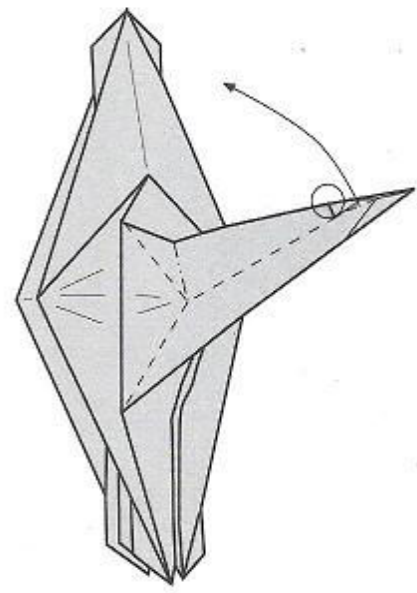

57

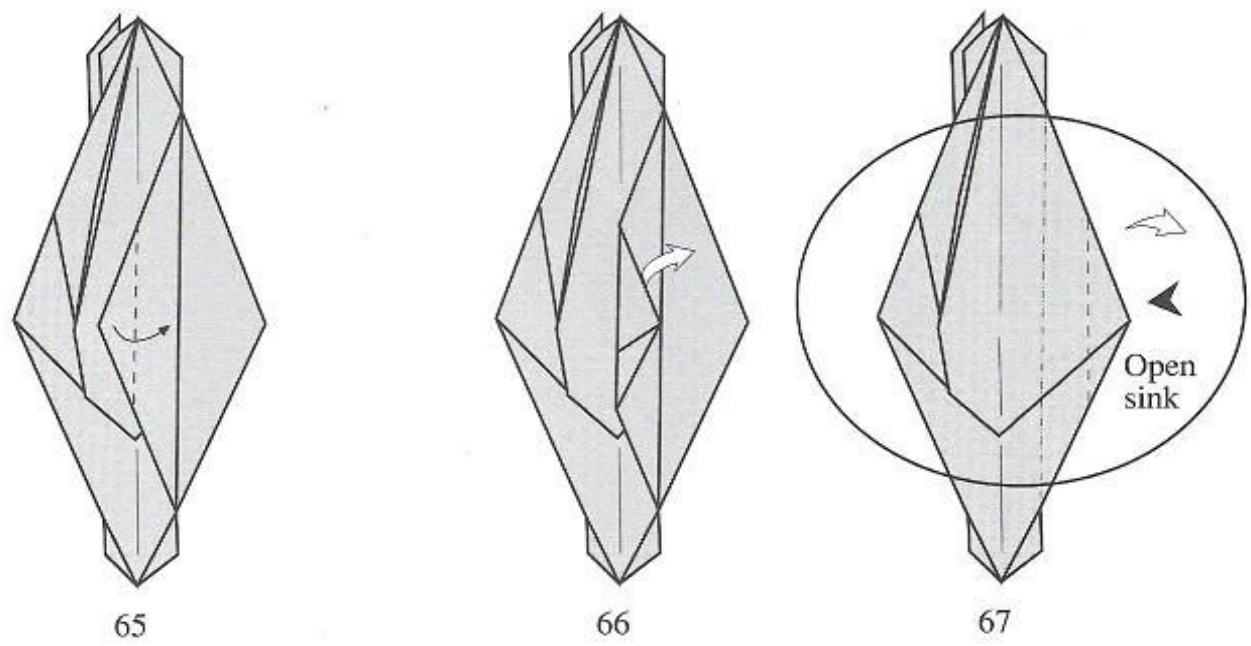
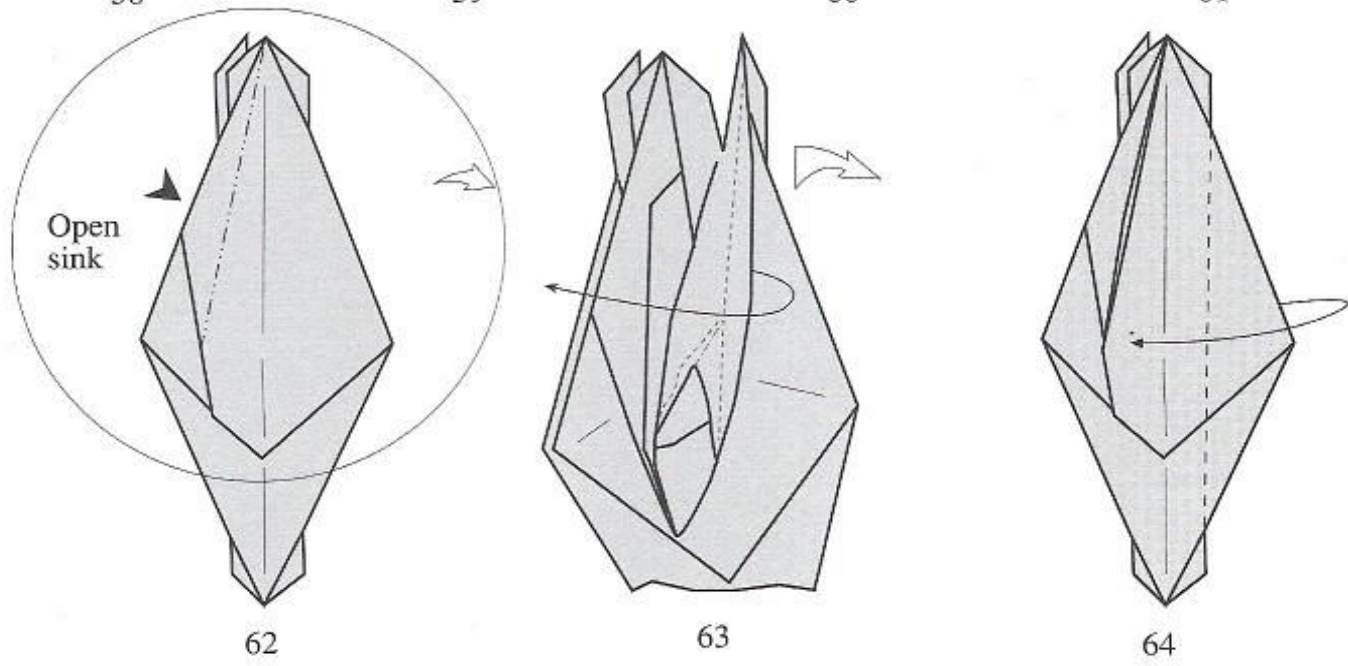
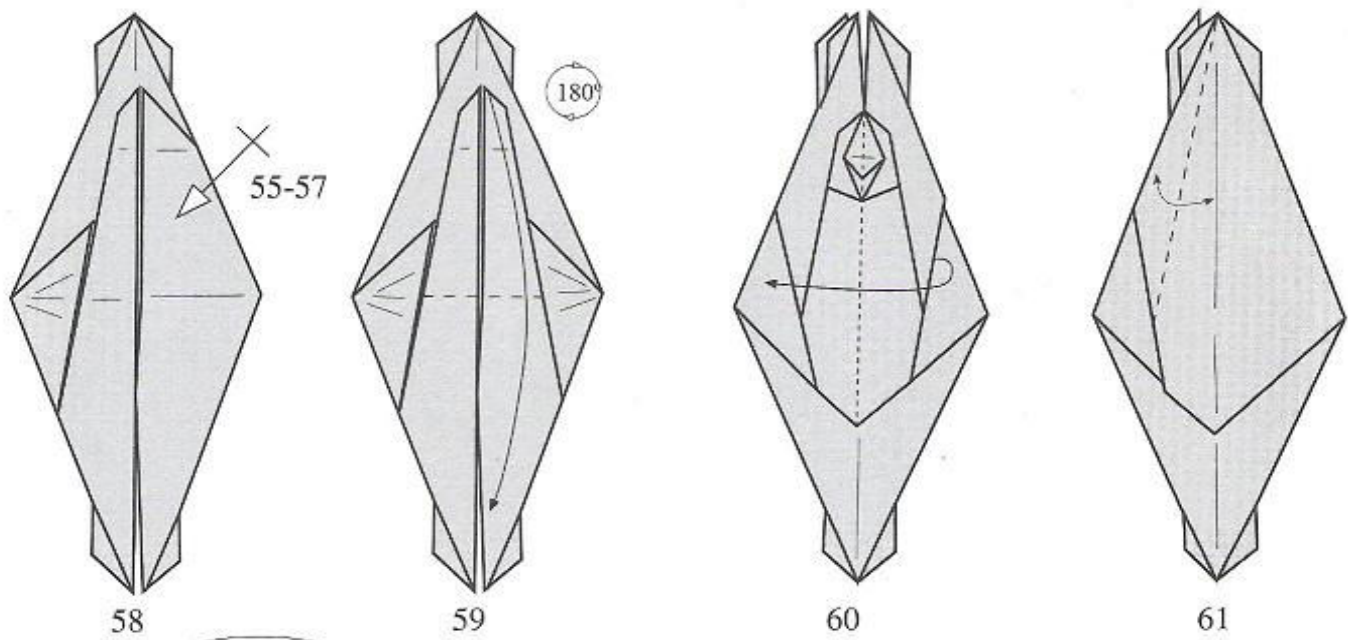

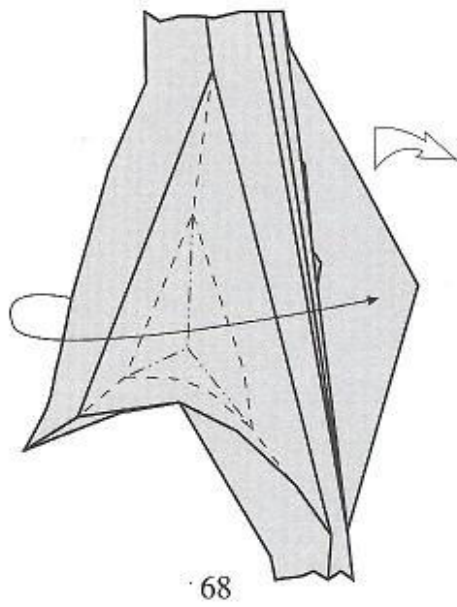

68

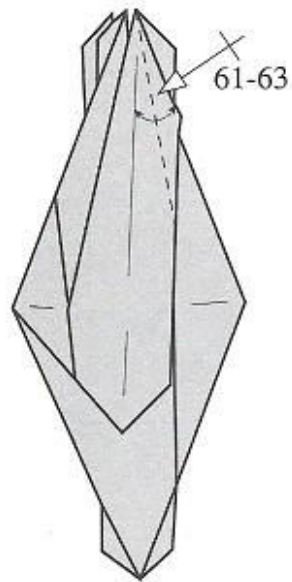

69

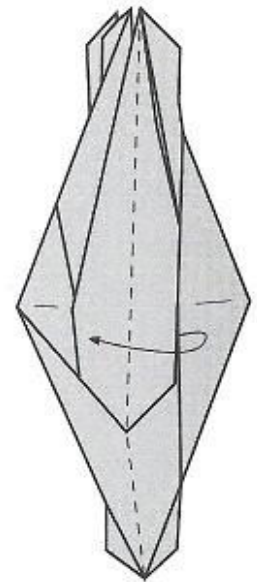

70

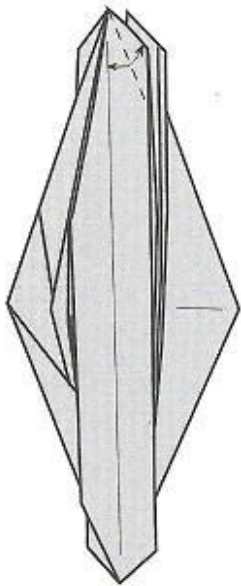

71

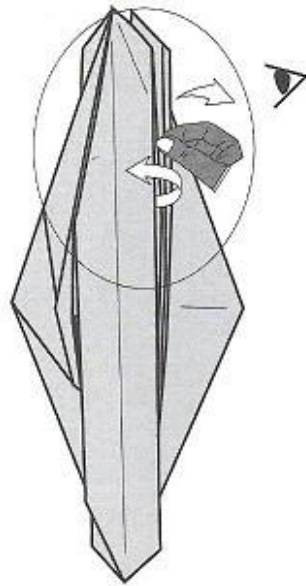

72



73

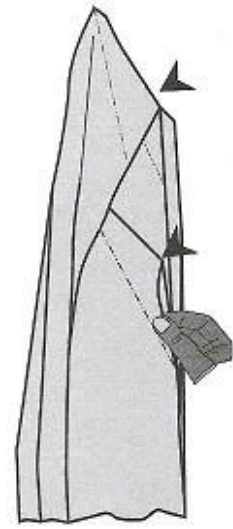

74

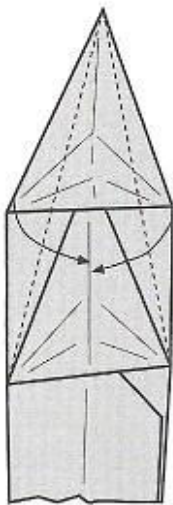

75

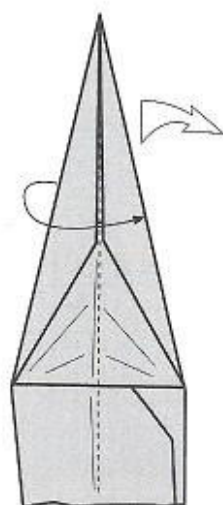

76

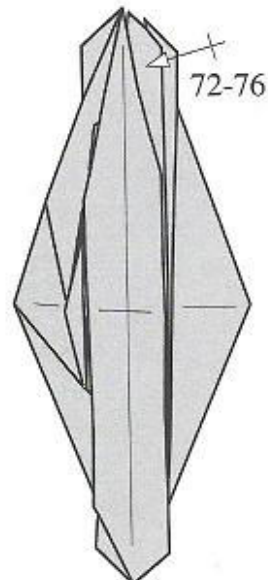

77

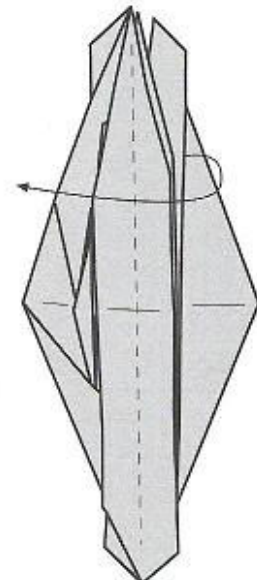

78

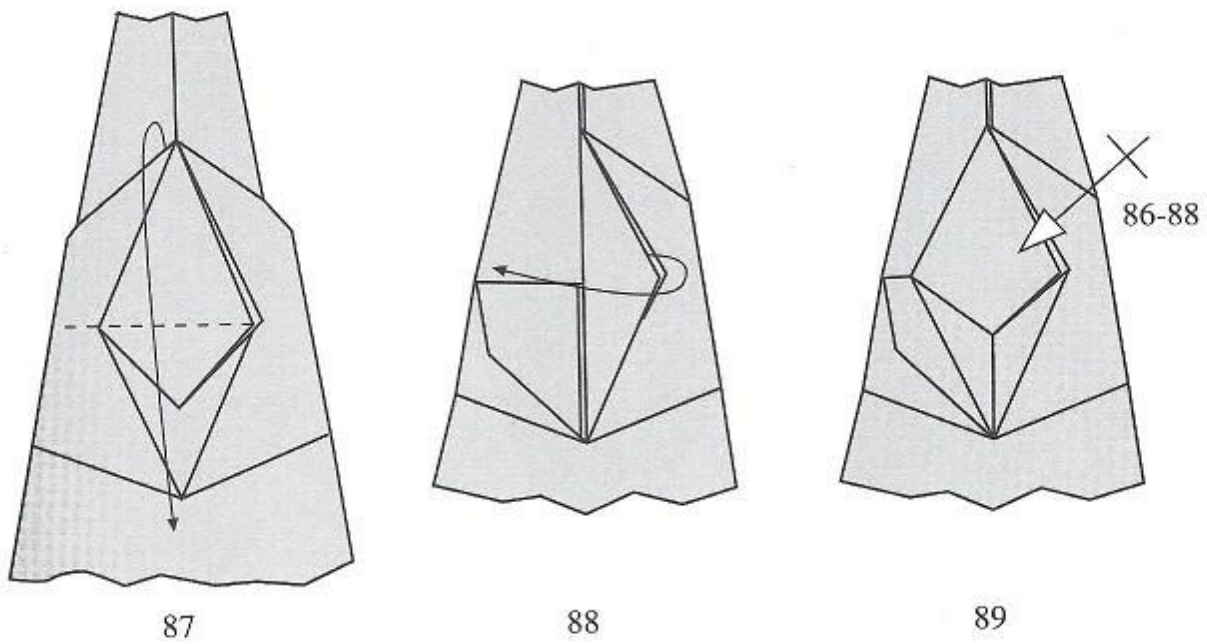
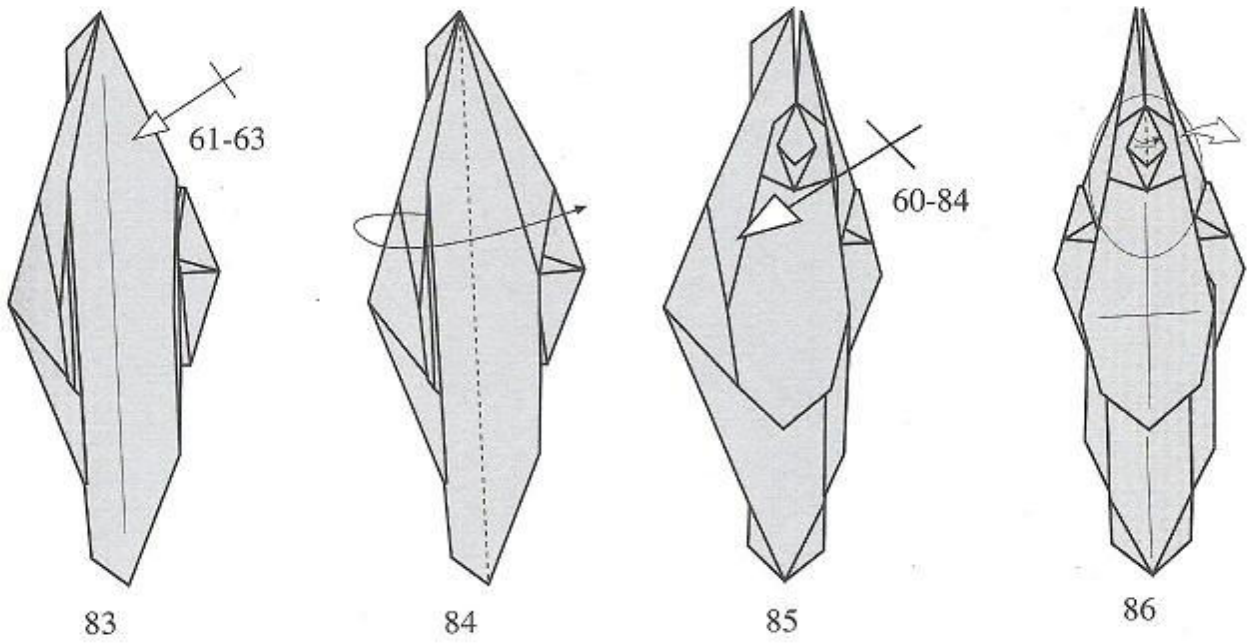
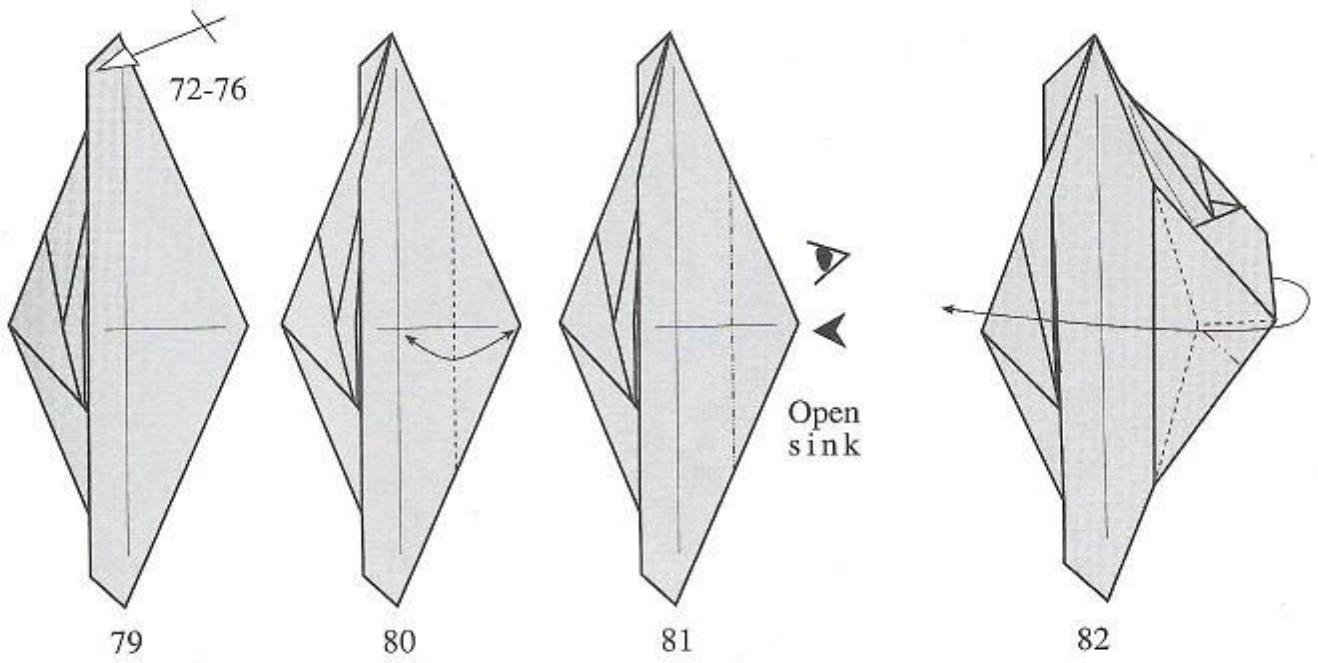

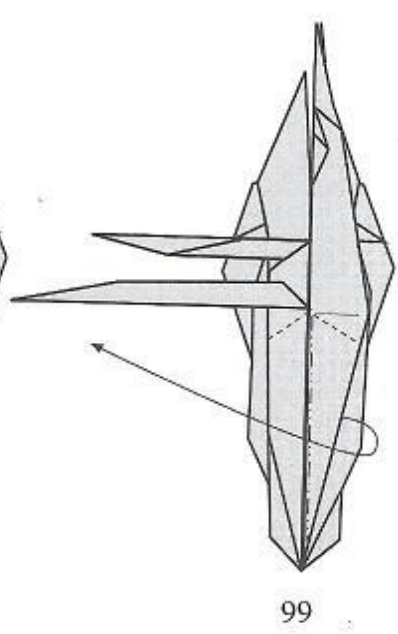
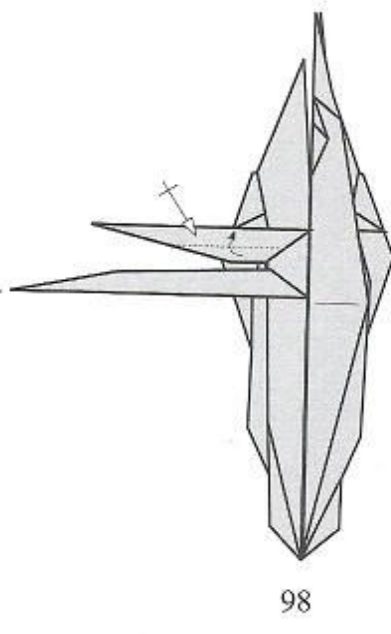
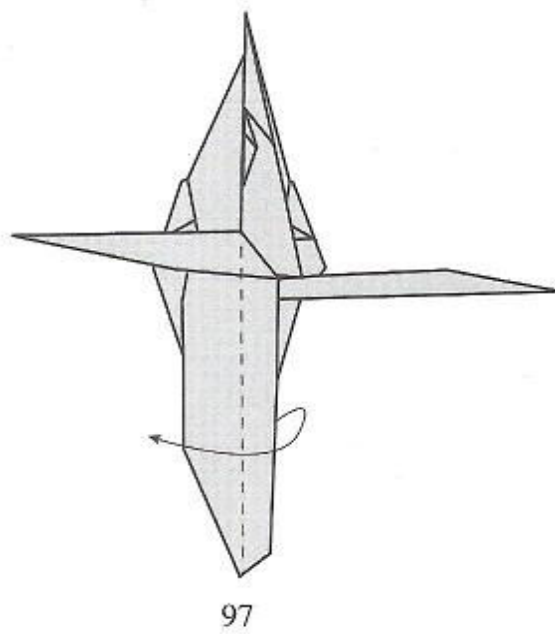
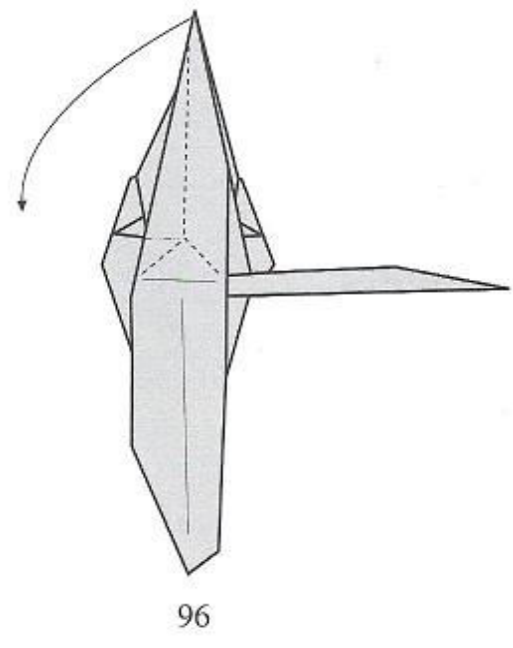
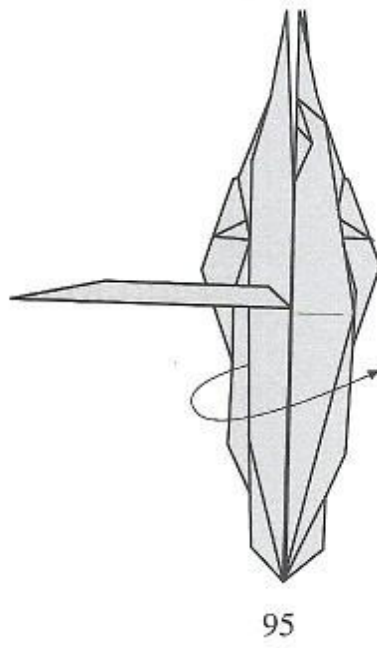
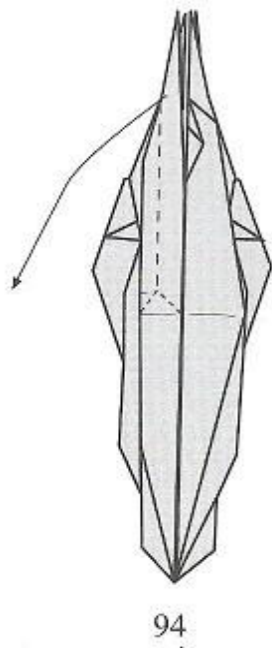
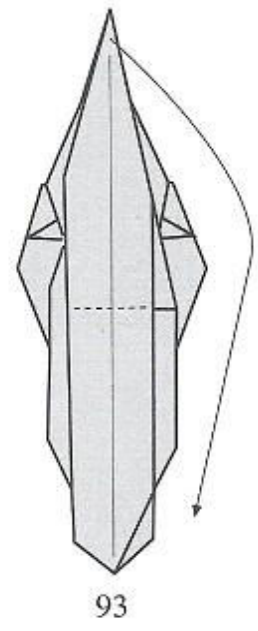
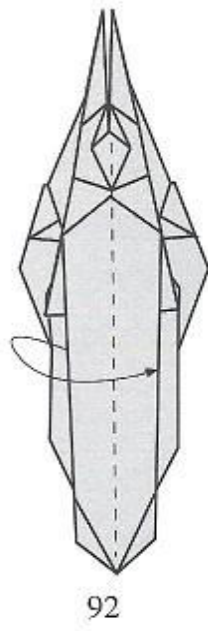
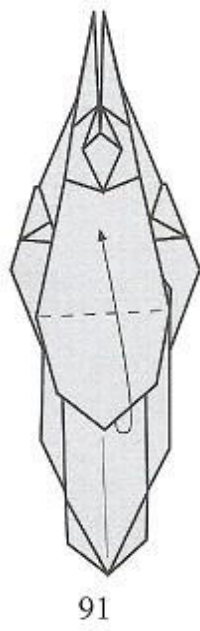
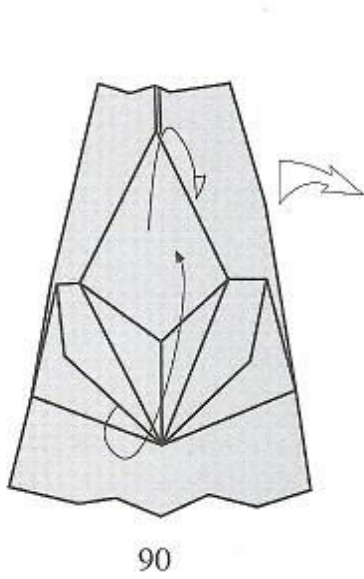

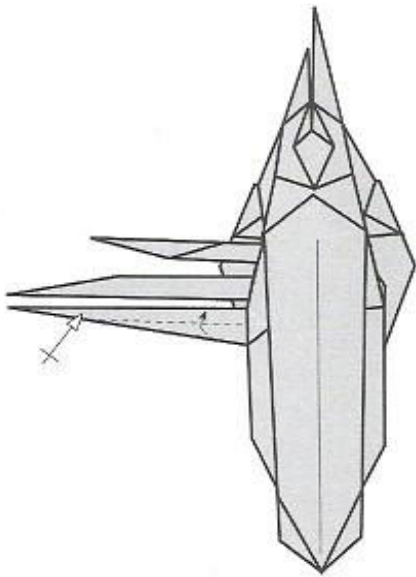

100

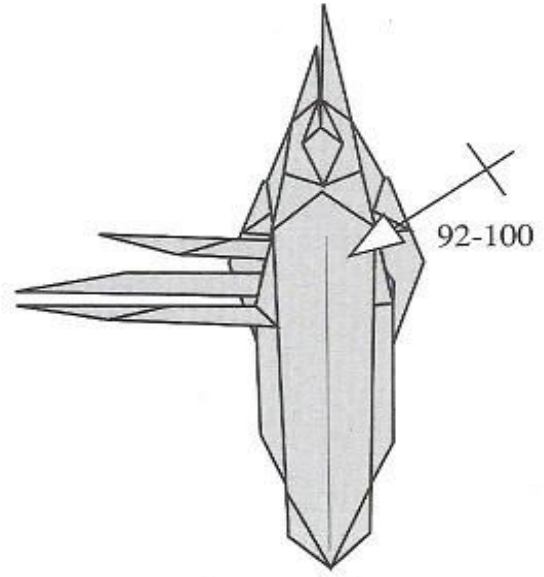

101

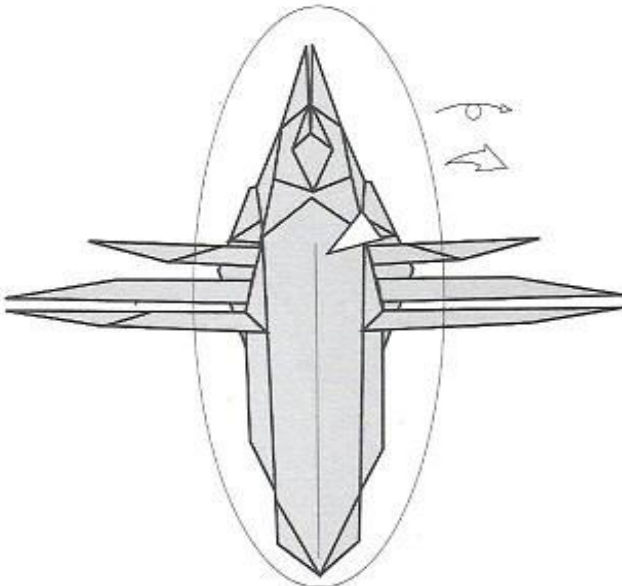

102

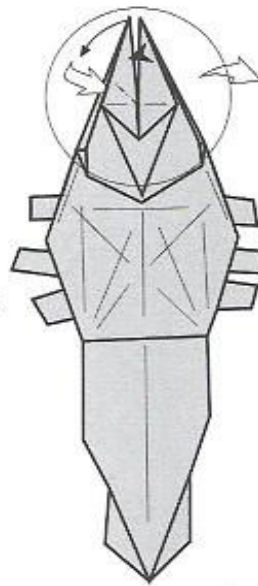

103

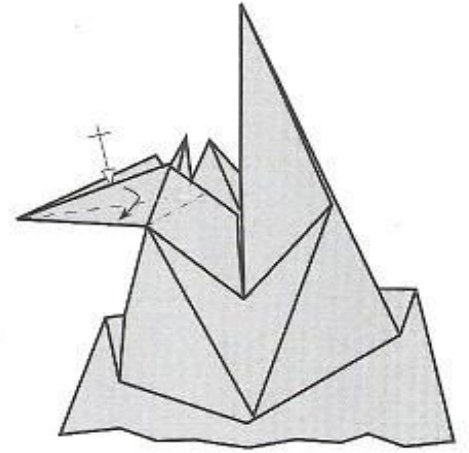

104

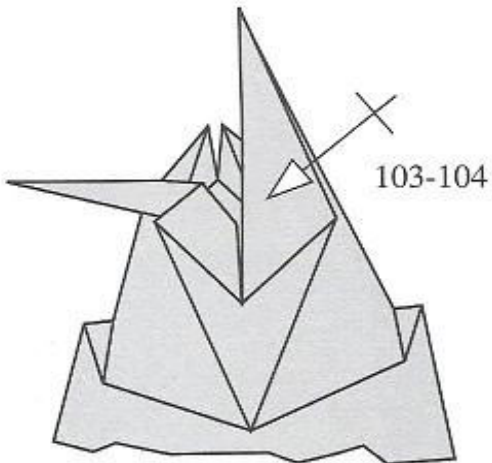

105

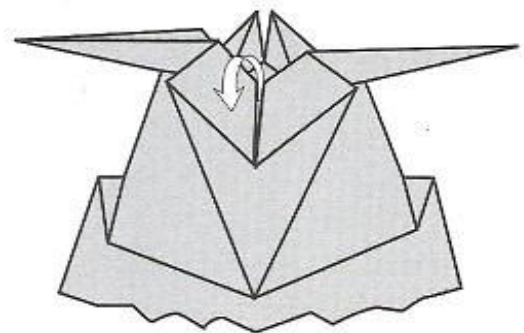

106

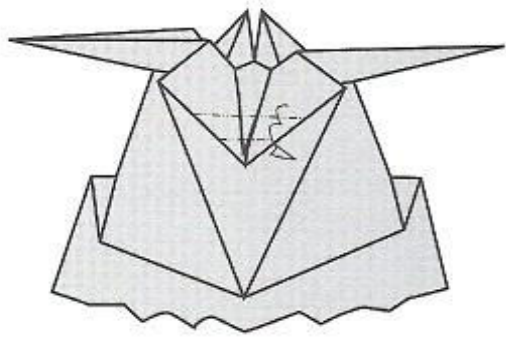

107

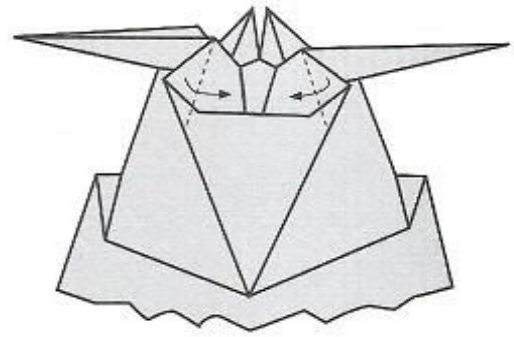

108

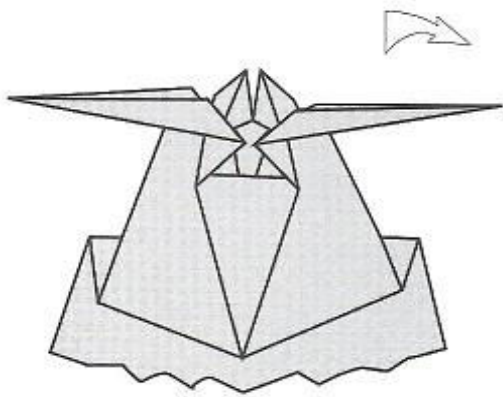

109

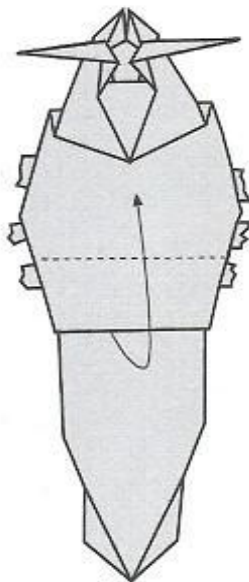

110

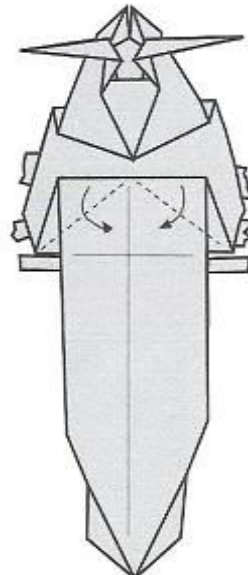

111

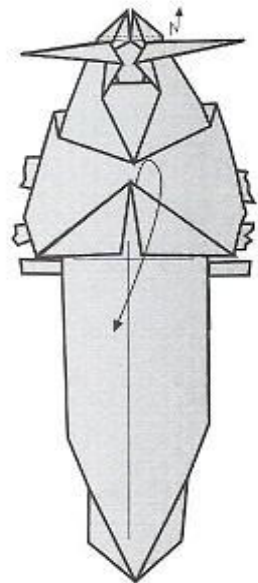

112

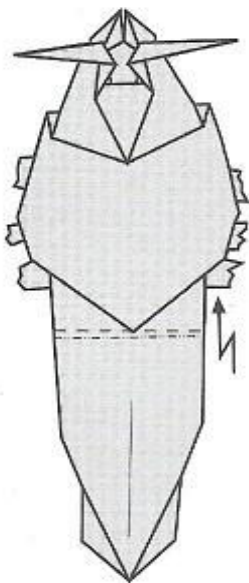

113

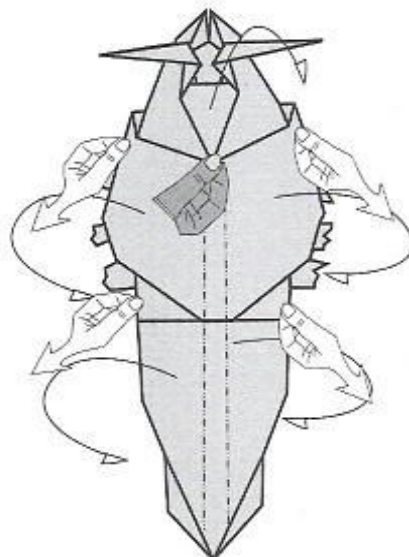

114

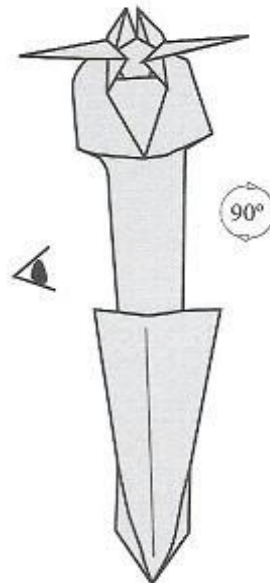

115

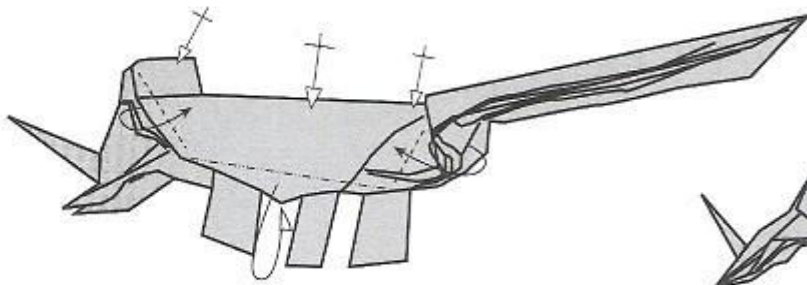

116

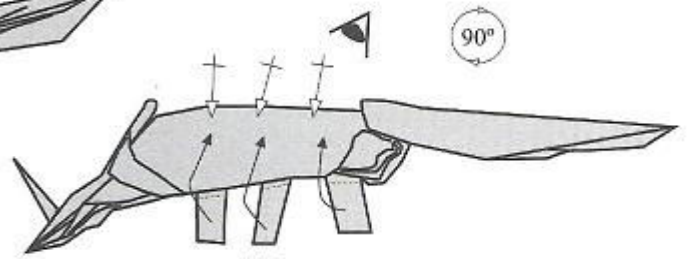

117

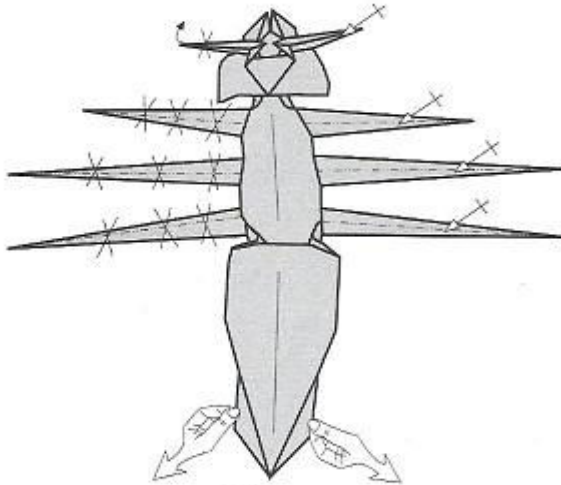

118

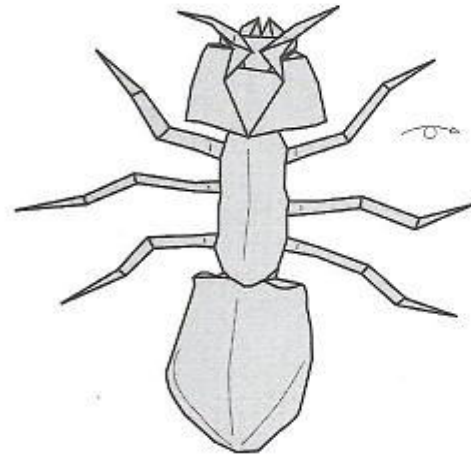

119

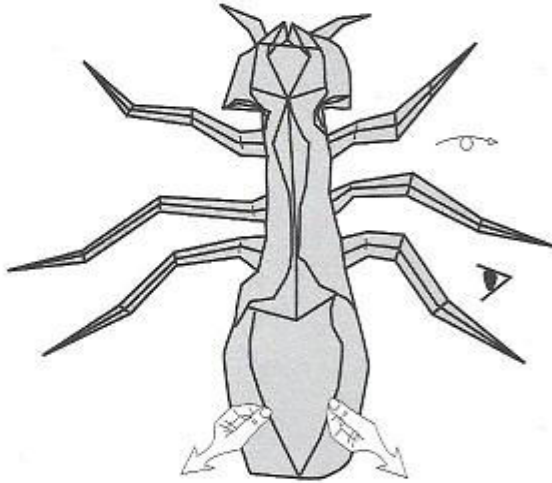

120

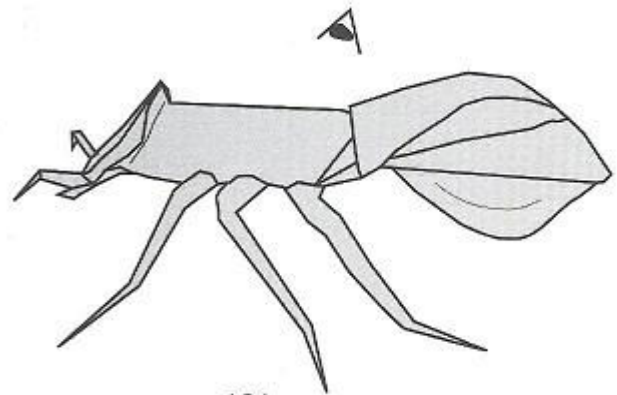

121

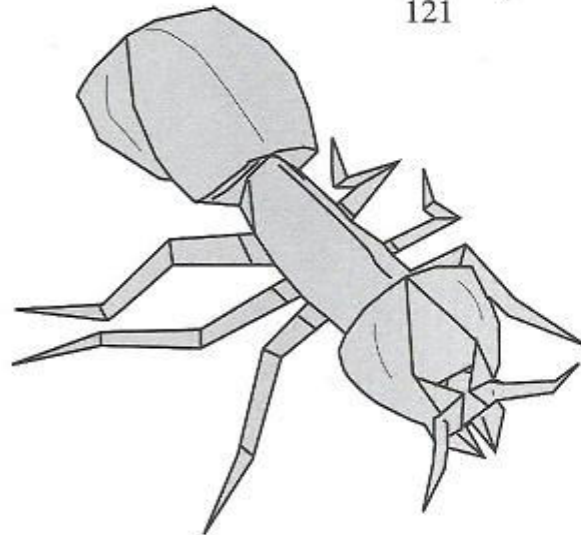

122

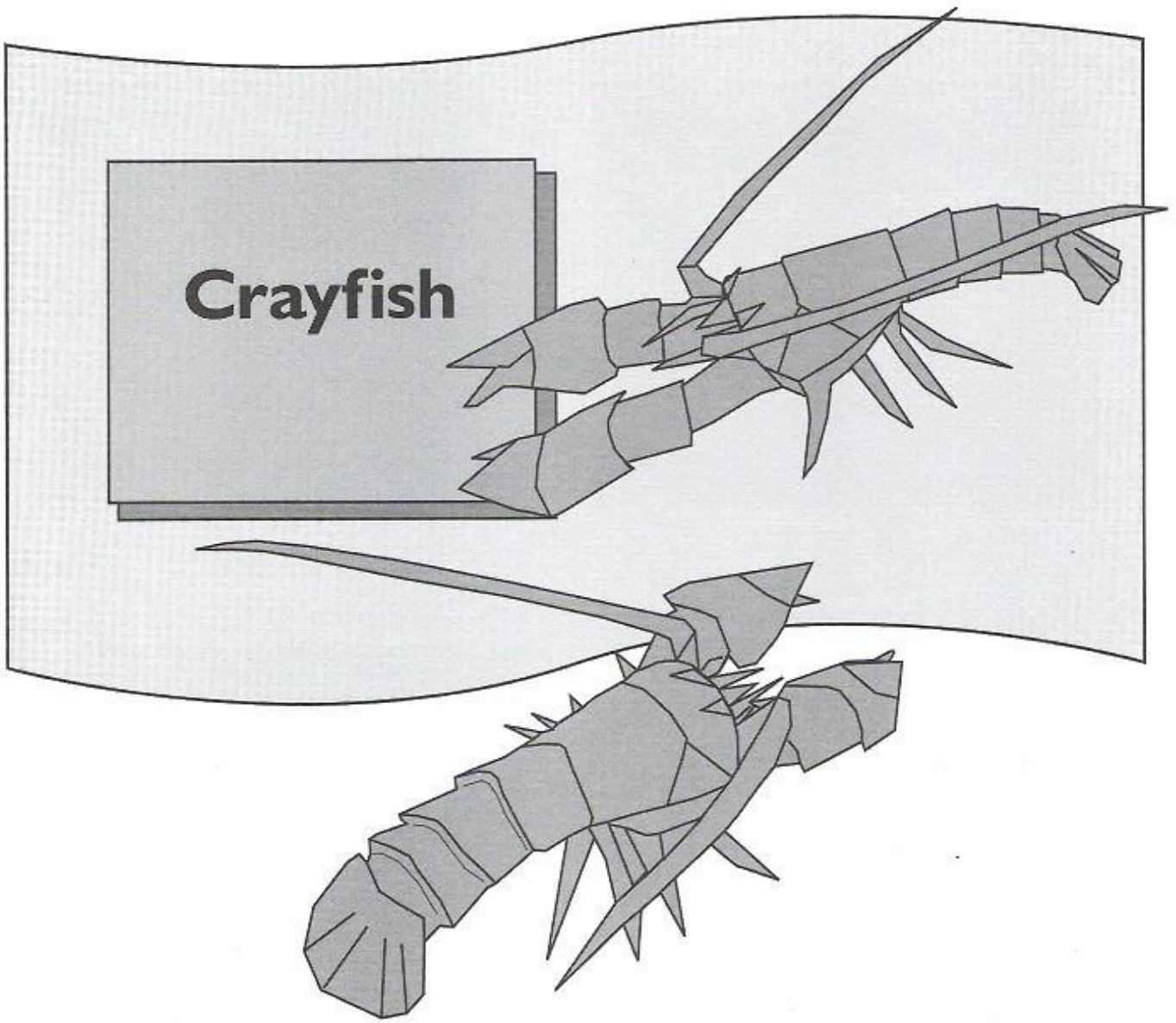

The paper should be dark green or black. Fine paper is recommended, less than 30 grams, double silk, banana tree, lokta, metallic or "sandwich," 11.8x11.8 inches (30x30 cm) or bigger.

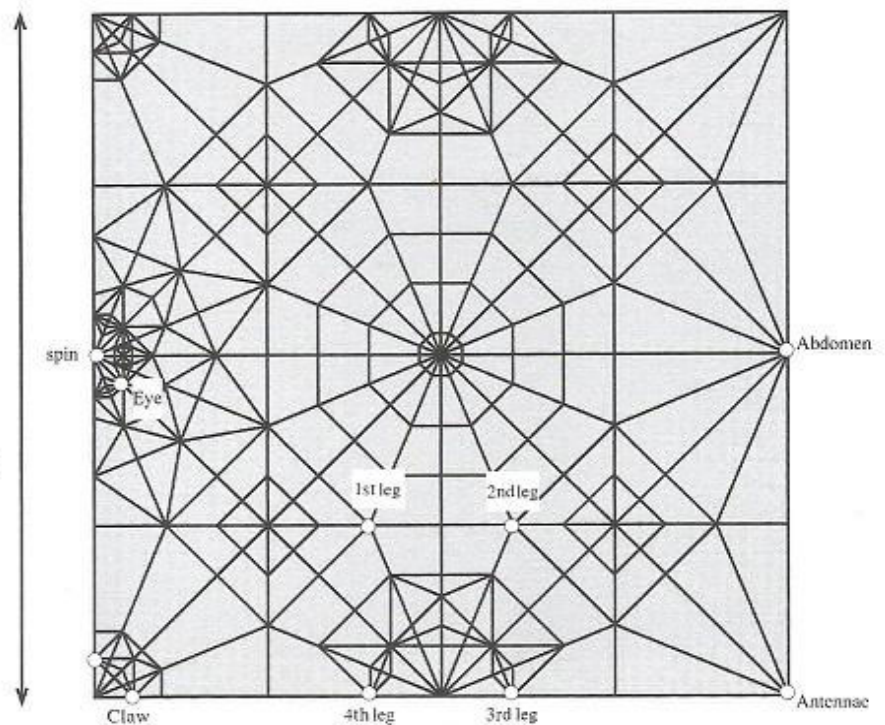
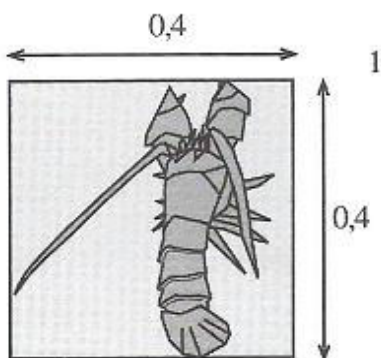

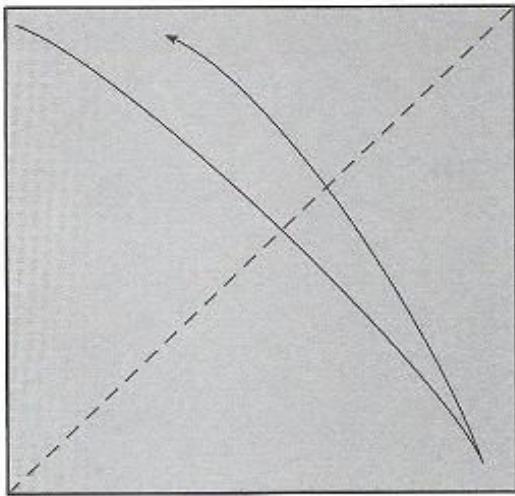

1 ⊖

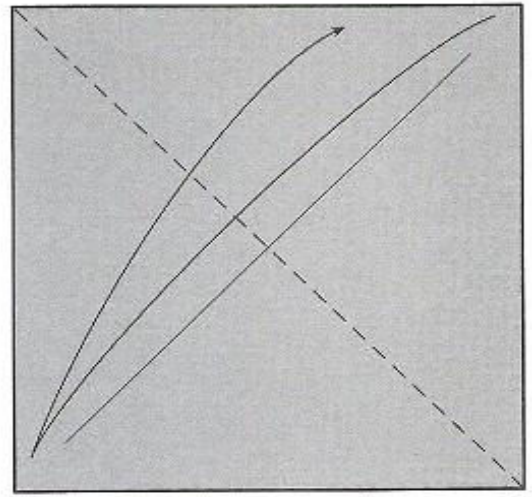

2

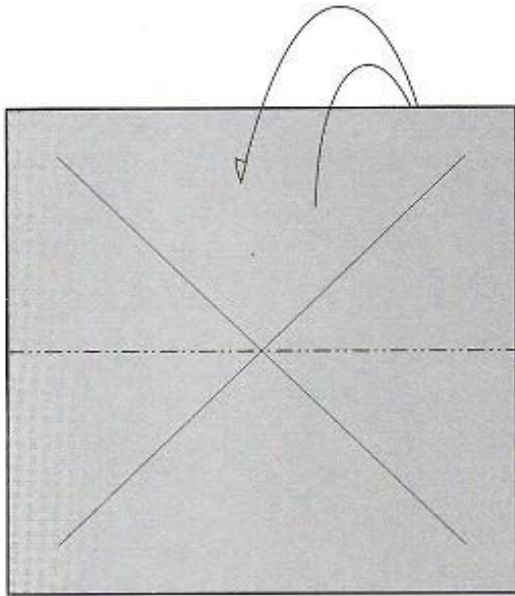

3

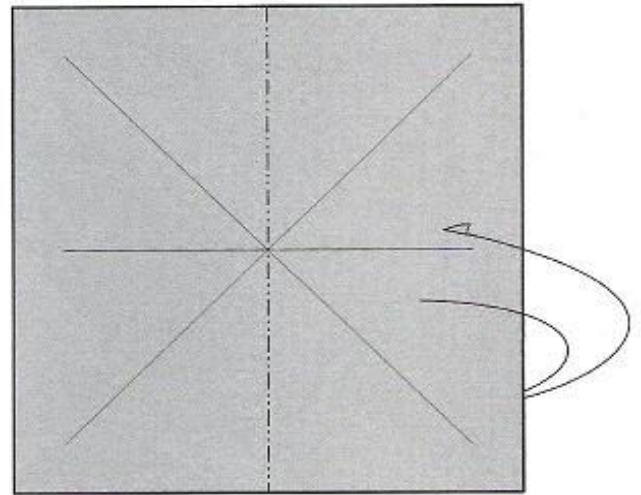

4

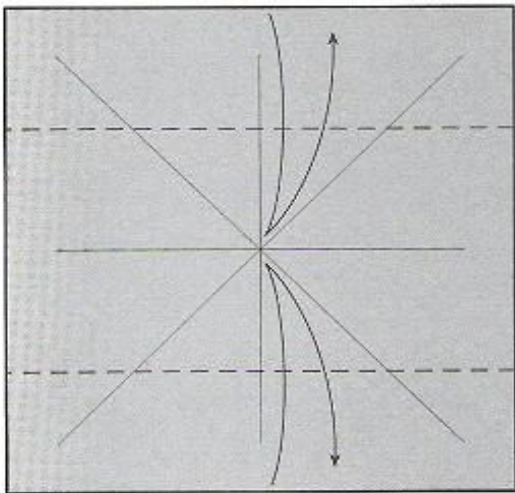

5

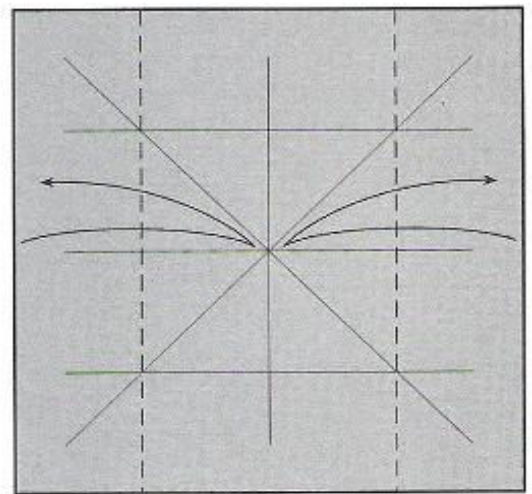

6

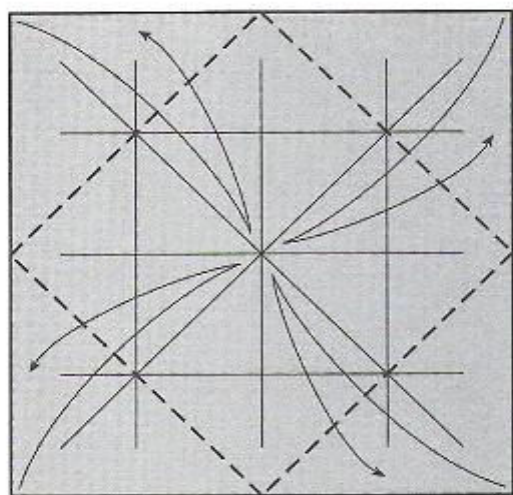

7

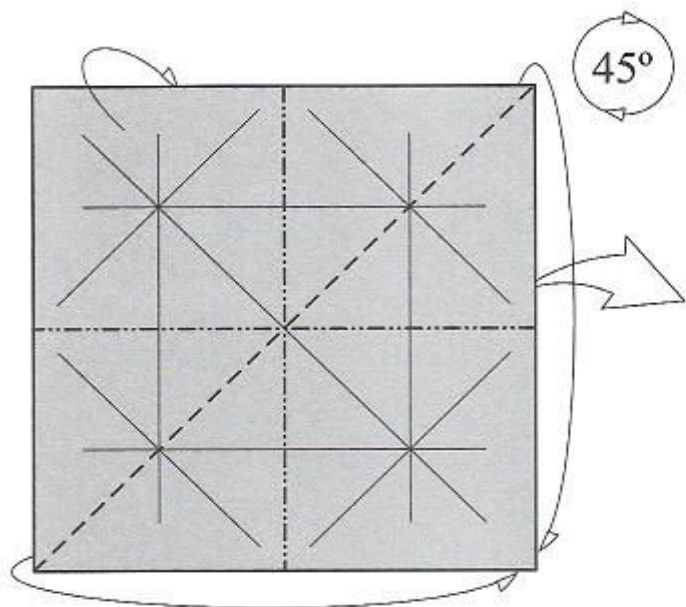

8

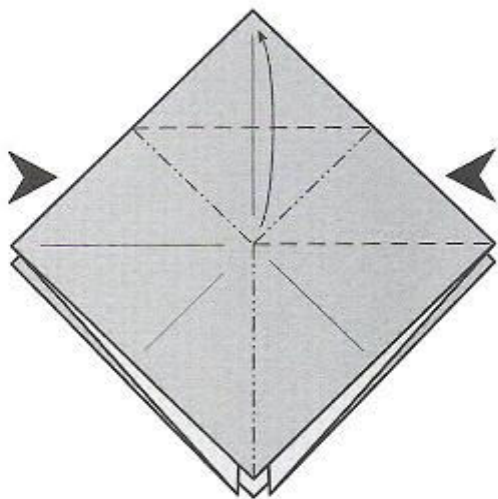

9

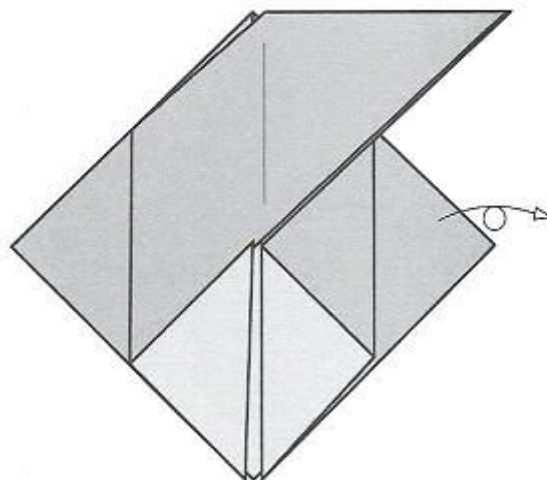

10

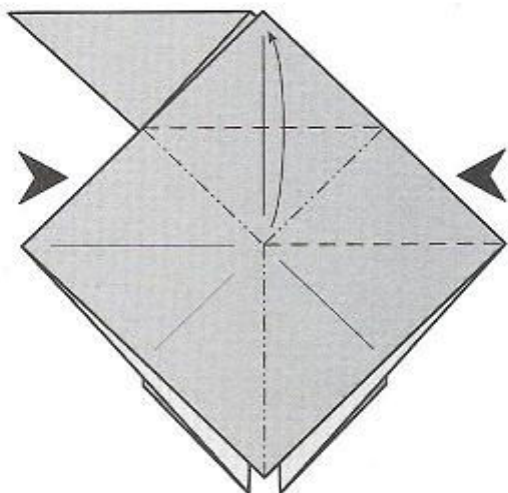

11

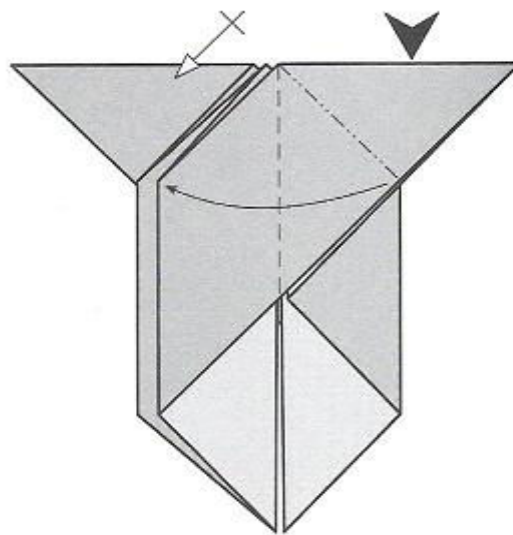

12

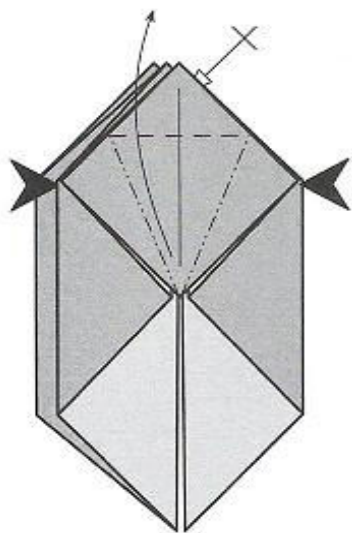

13

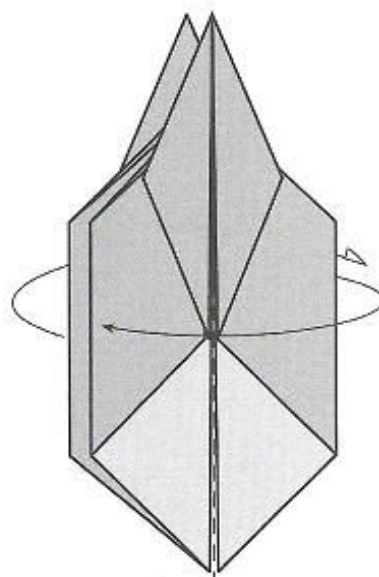

14

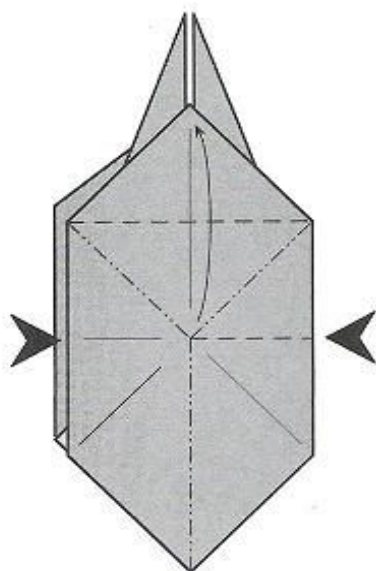

15

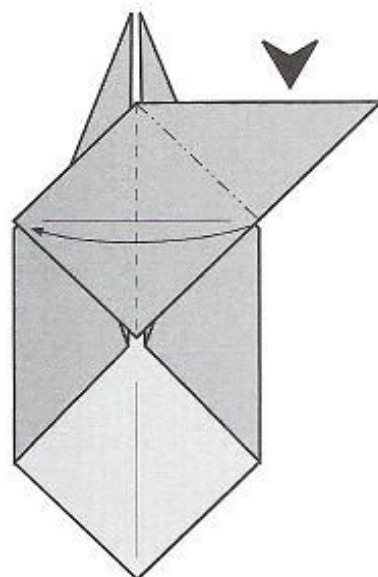

16

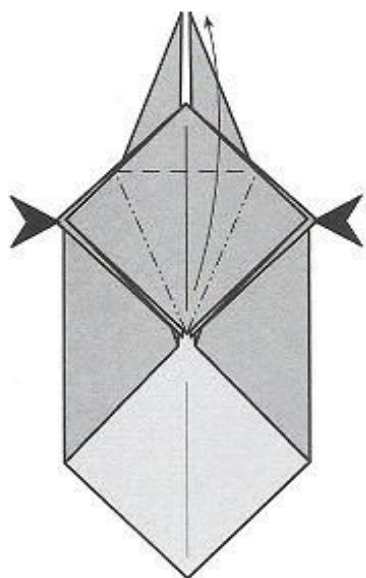

17

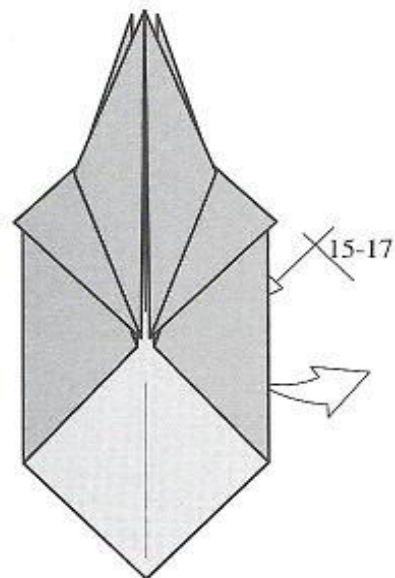

18

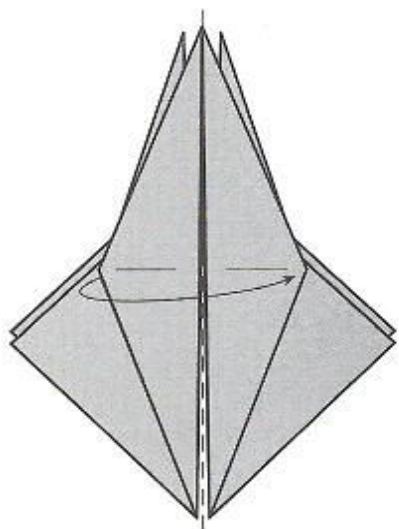

19

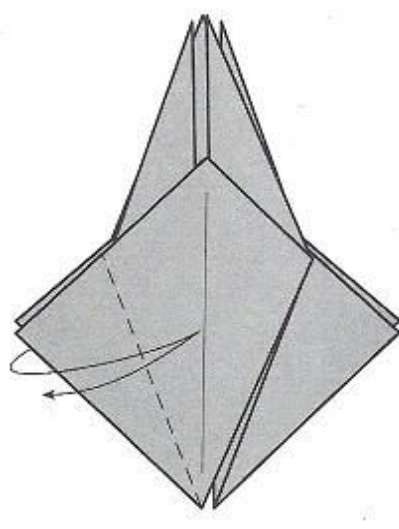

20

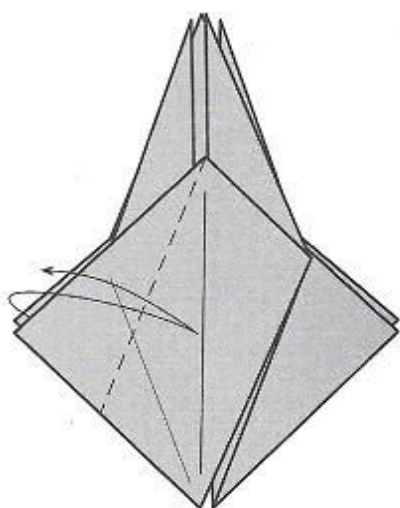

21

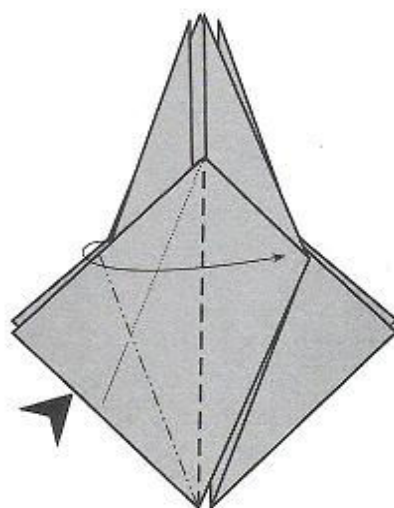

22

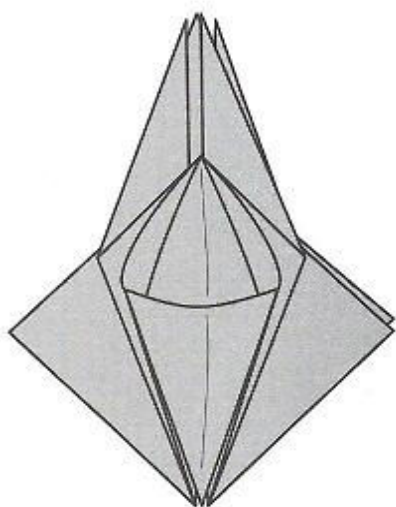

23

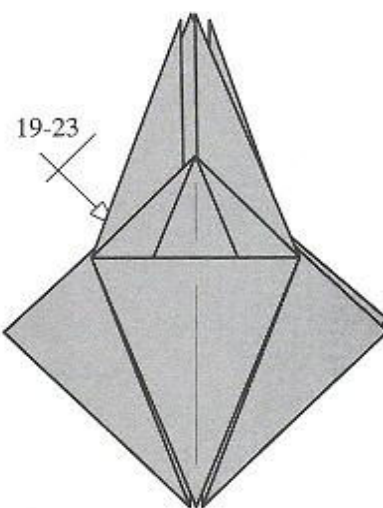

24

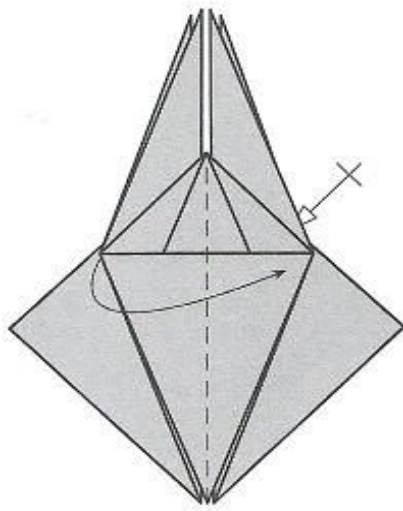

25

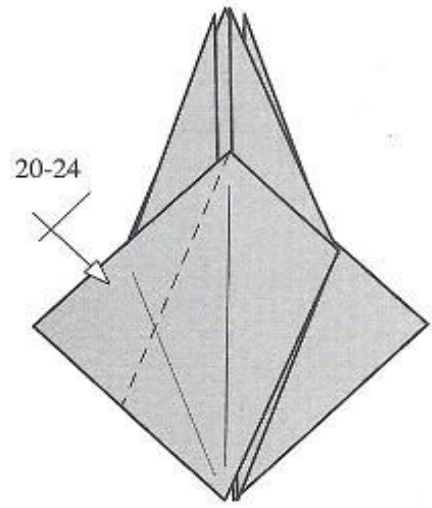

26

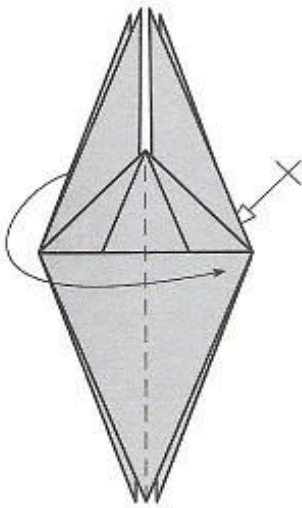

27

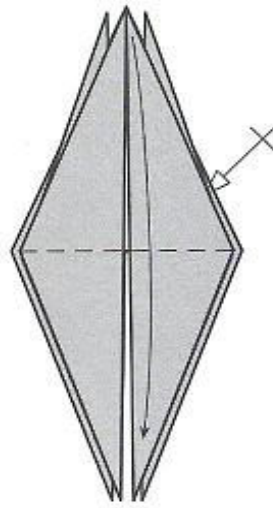

28

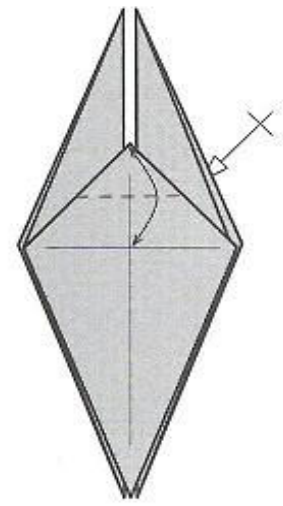

29

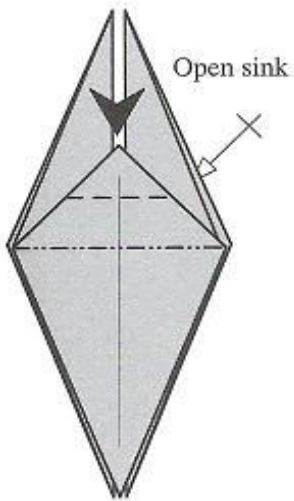

30

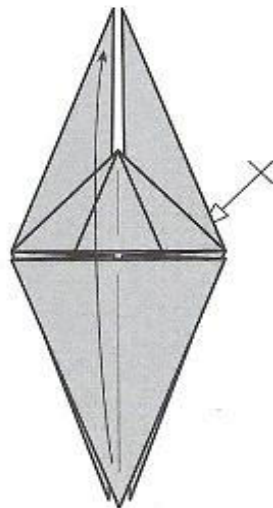

31

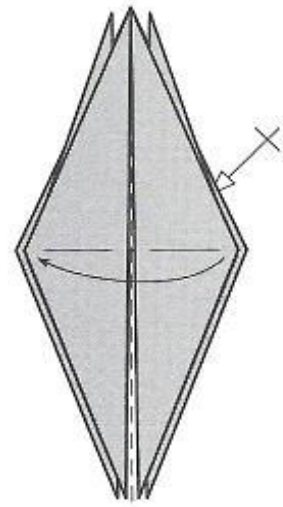

32

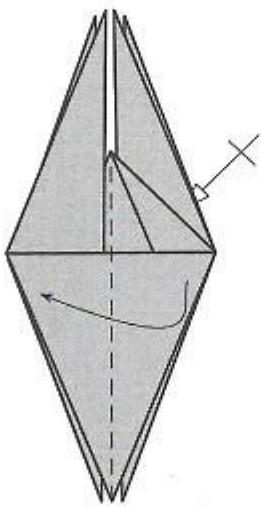

33

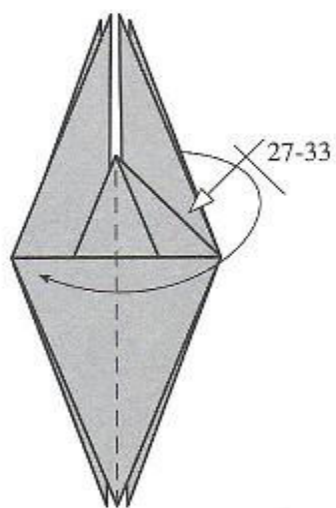

34

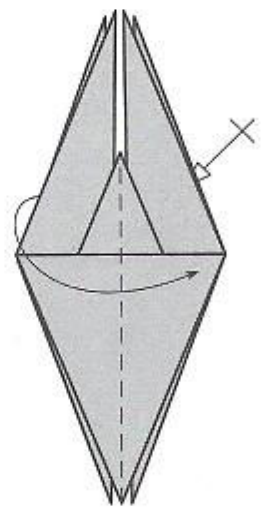

35

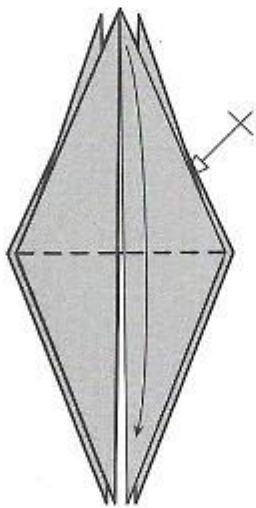

36

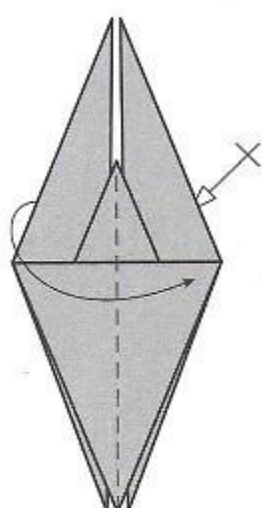

37

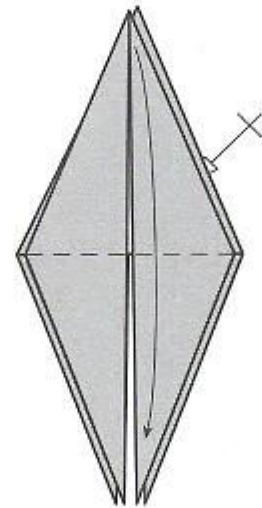

38

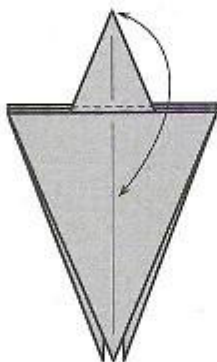

39

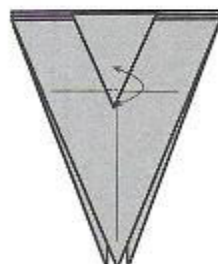

40



41

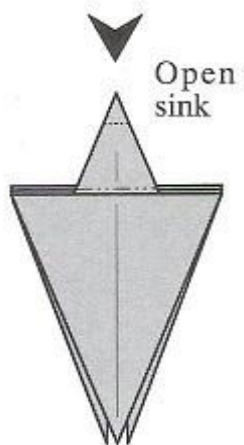

42



43

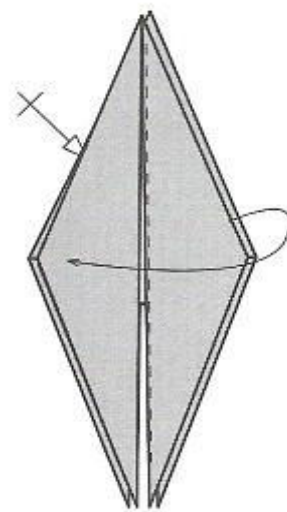

44

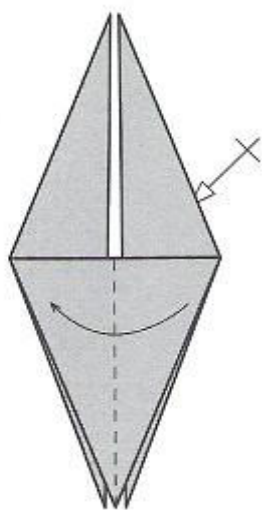

45

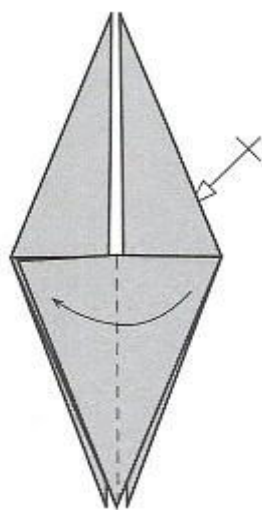

46

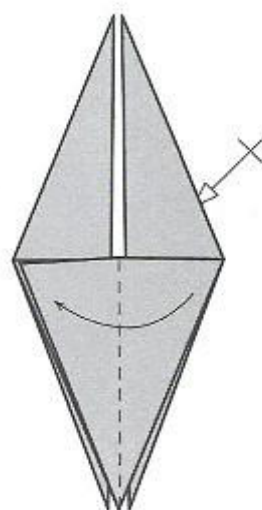

46-A

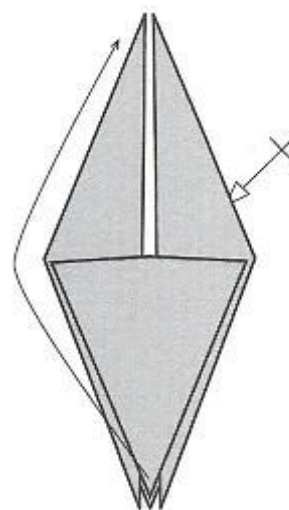

47

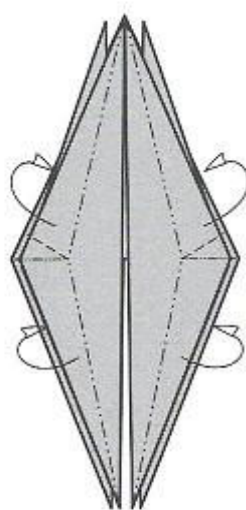

48

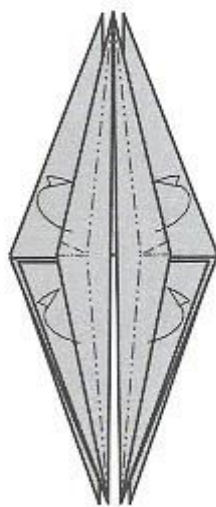

49

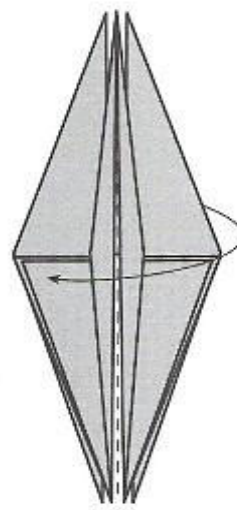

50

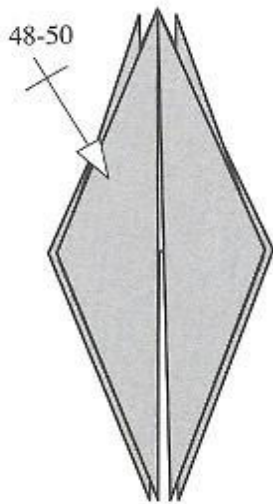

51

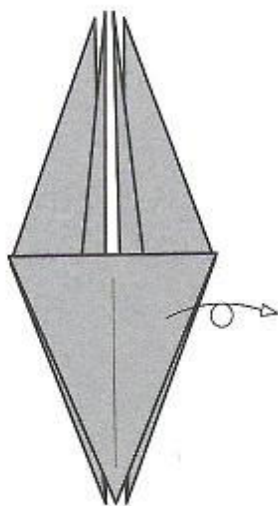

52

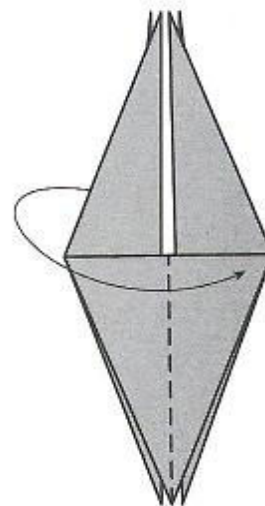

53

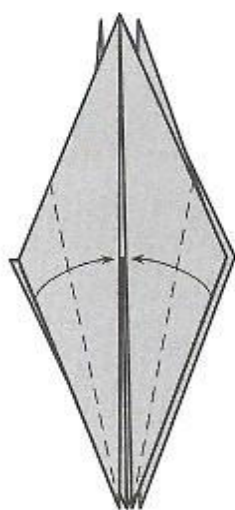

54



55

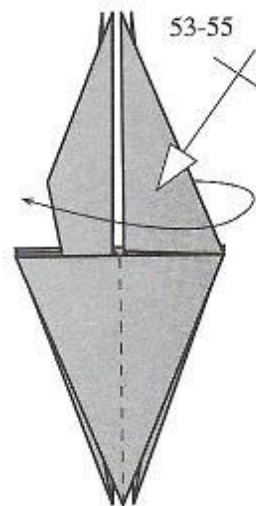

56

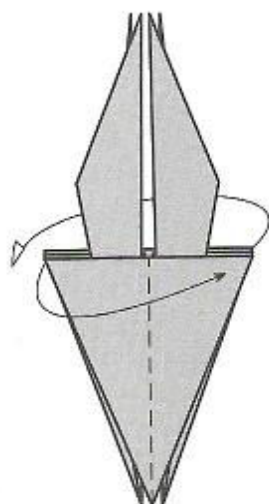

57

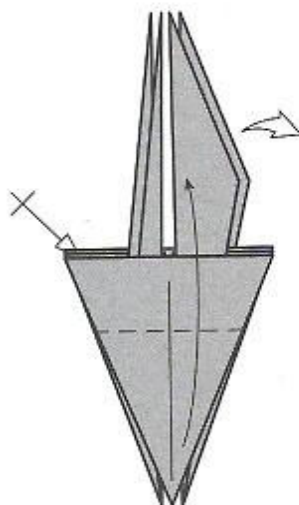

58

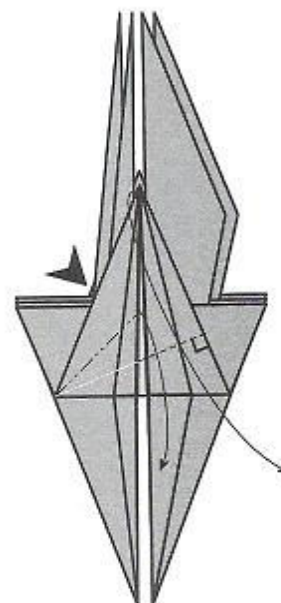

59

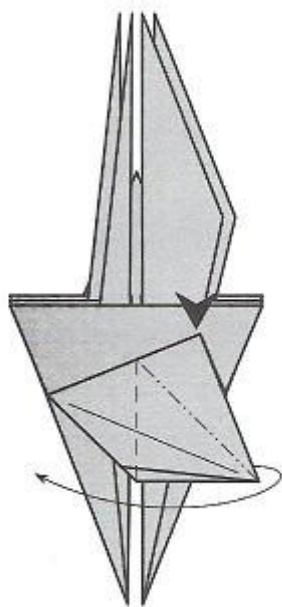

60

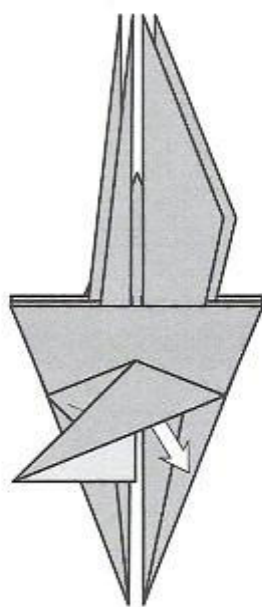

61

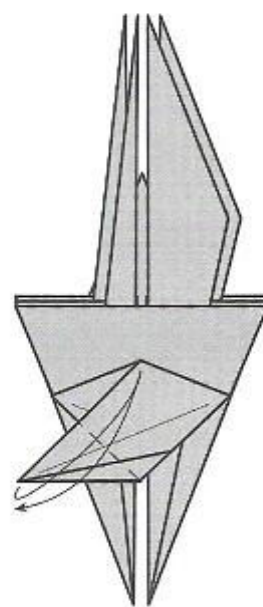

62

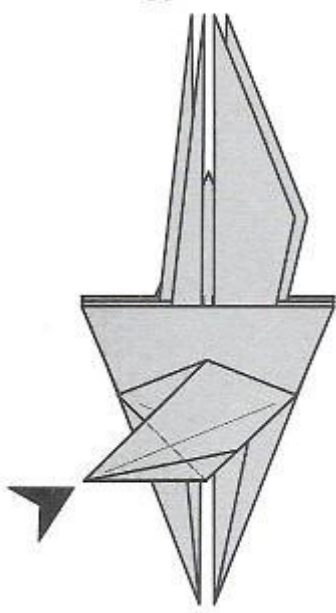

63

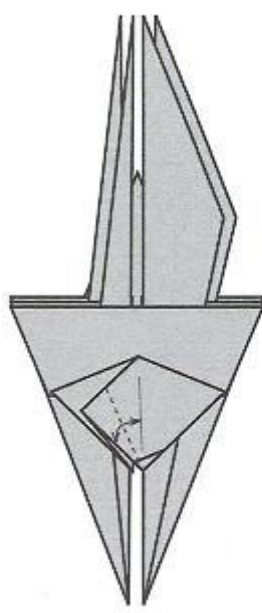

64

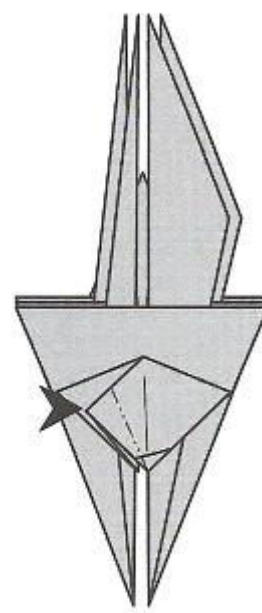

65

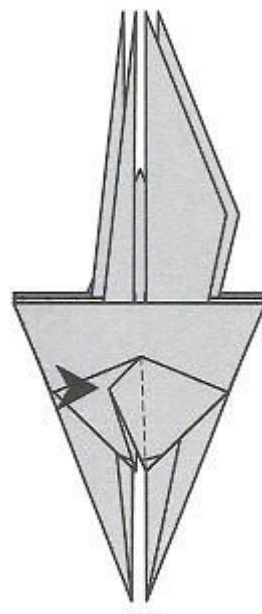

66

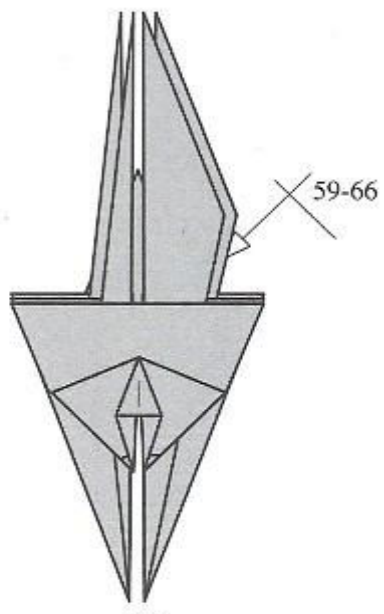

67

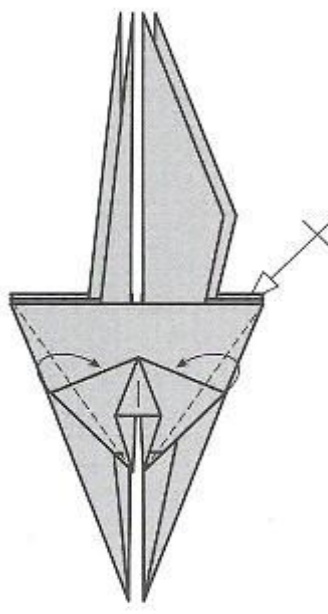

68

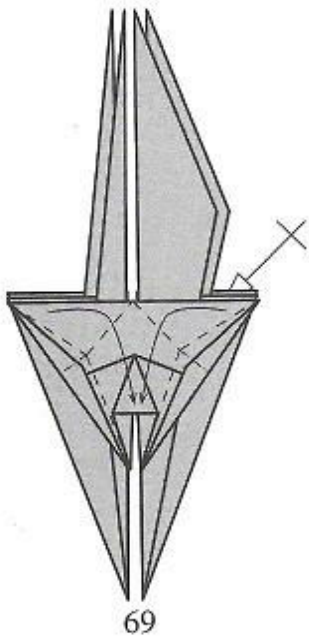

69

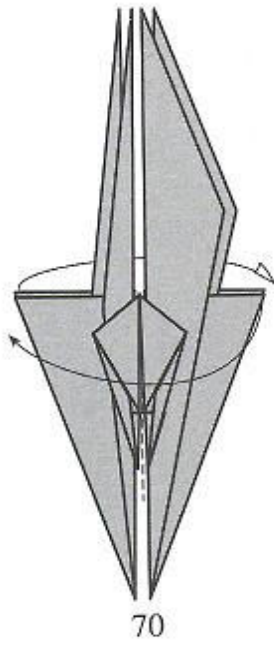

70

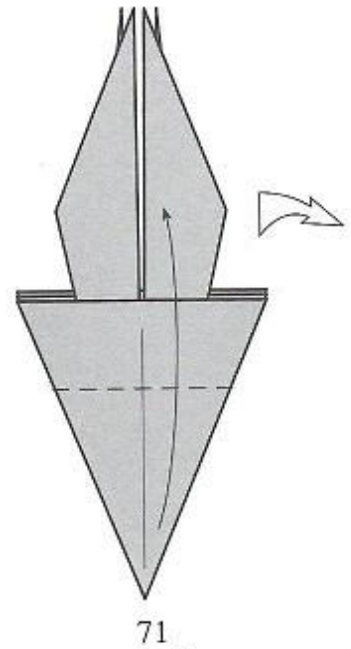

71

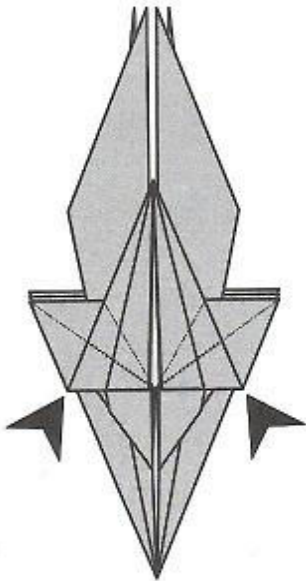

72

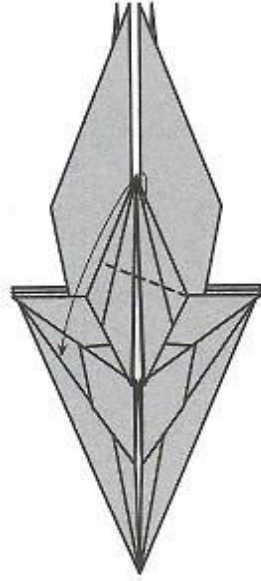

73

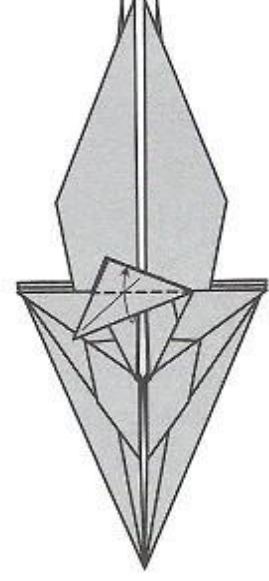

74

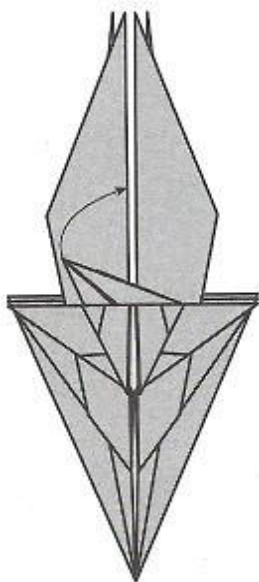

75

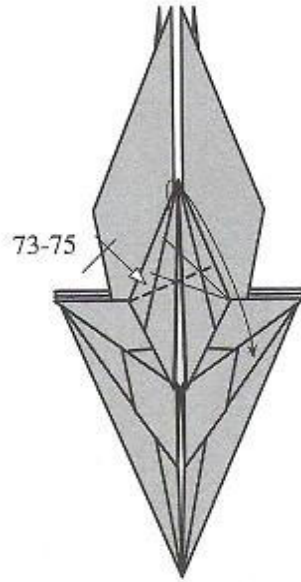

76

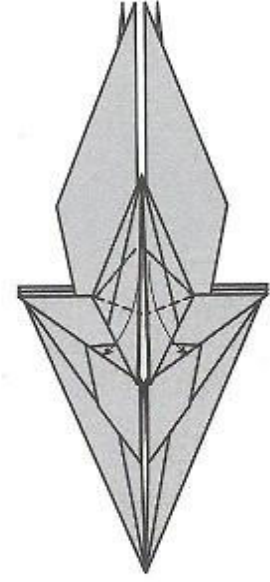

77

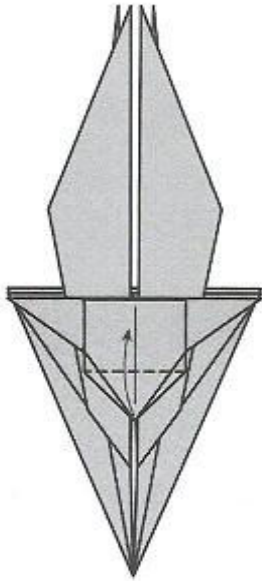

78

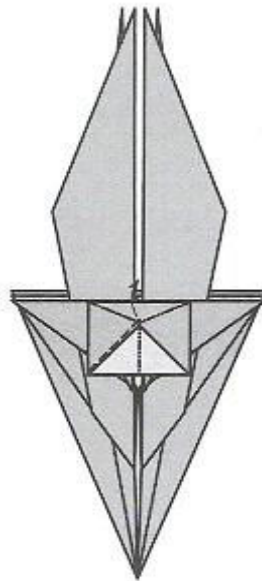

79

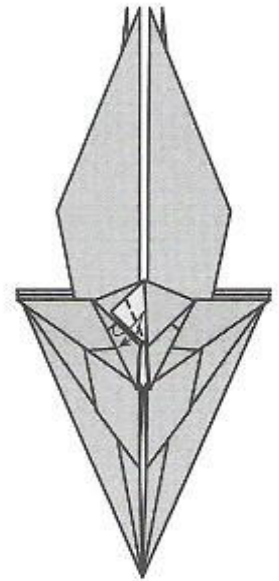

80

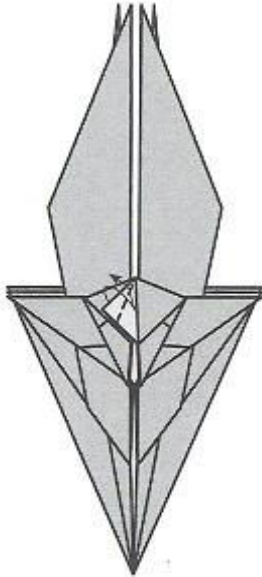

81

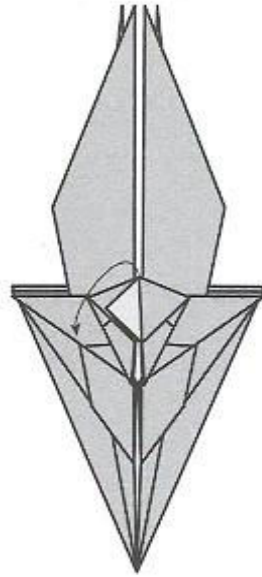

82

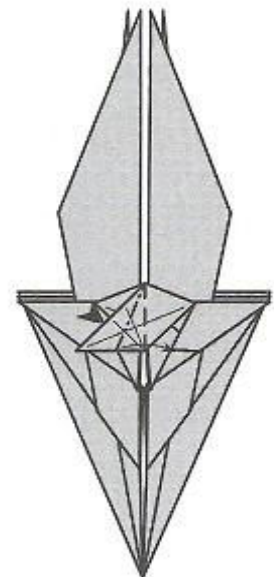

83

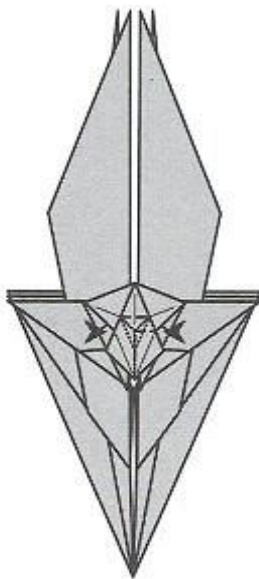

84

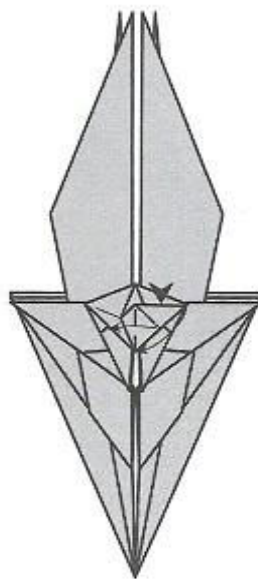

85

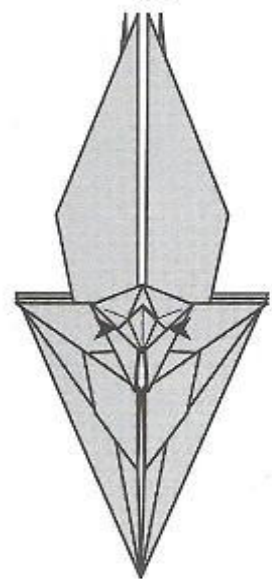

86

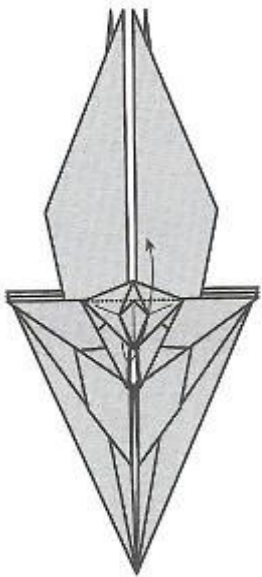

87

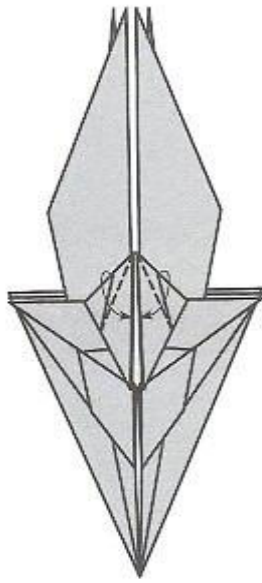

88

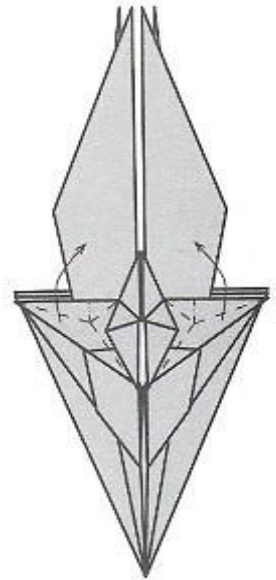

89

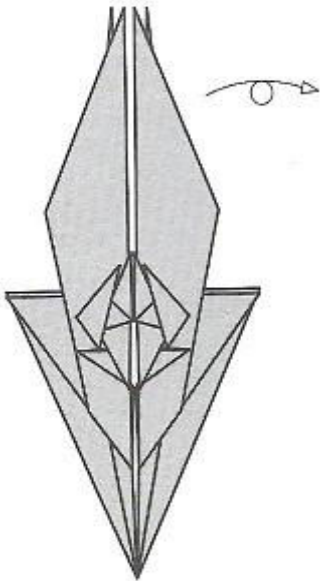

90

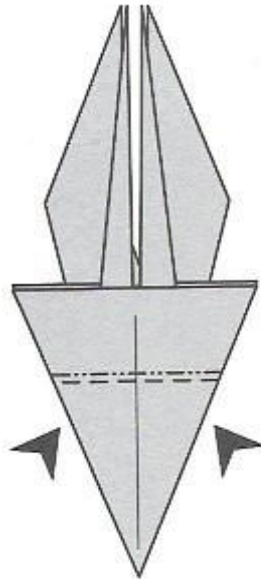

91

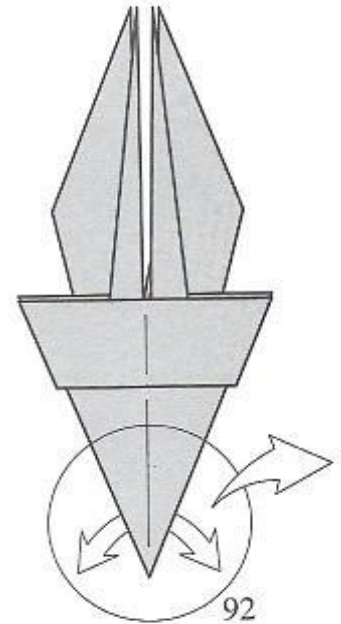

92

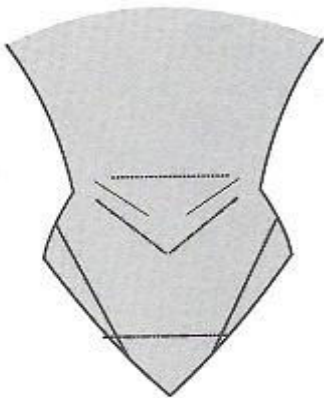

93

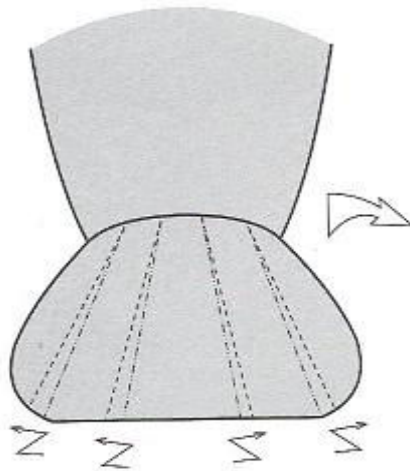

94

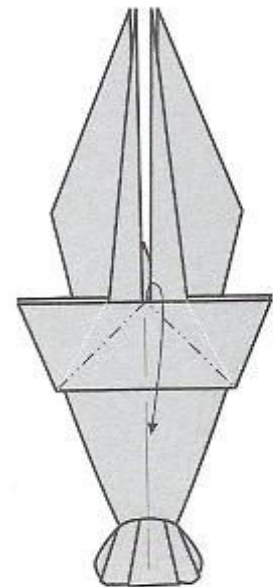

95

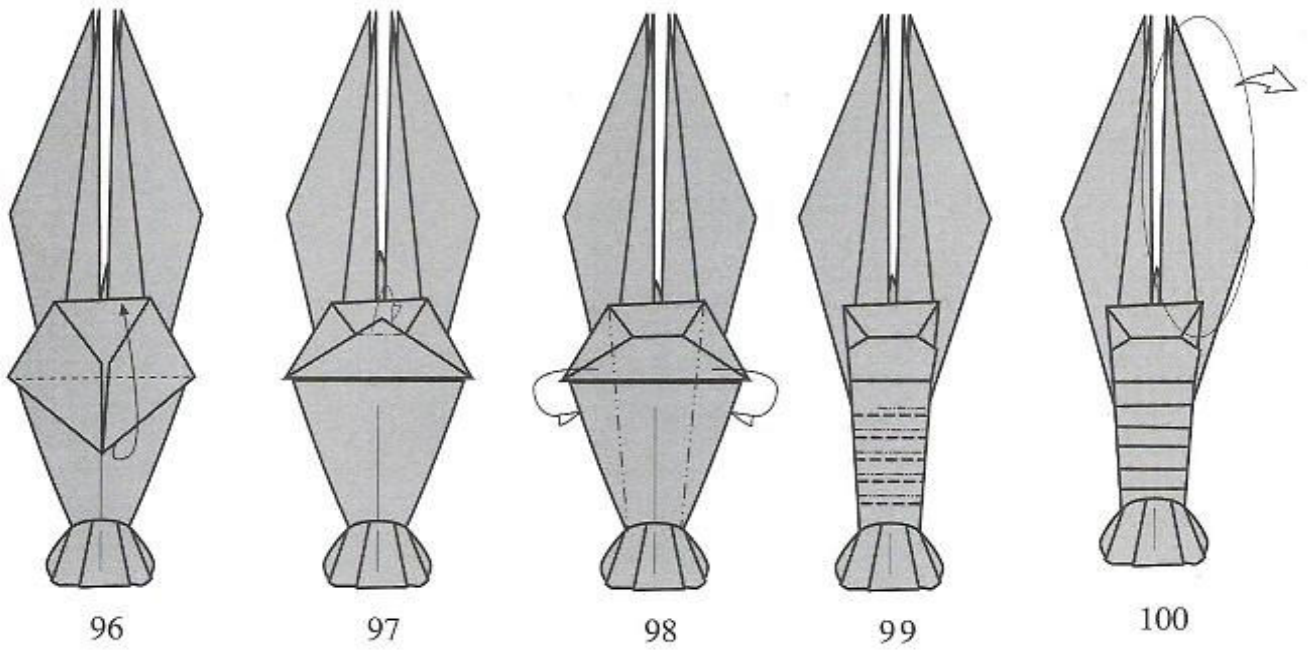

FOLDING OF THE CLAWS

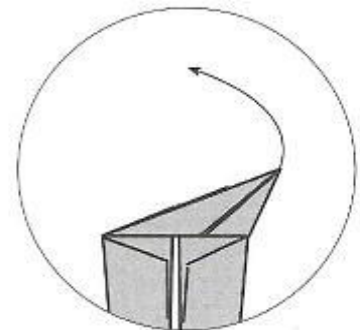
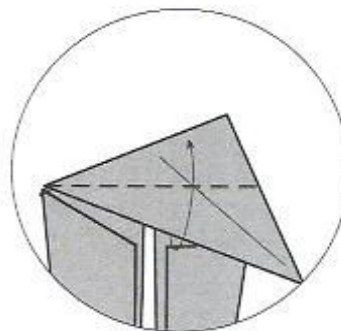
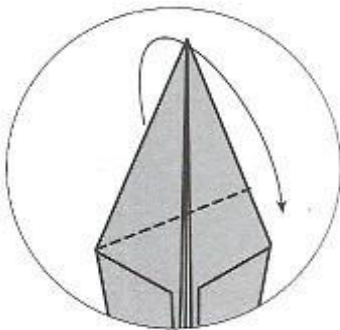
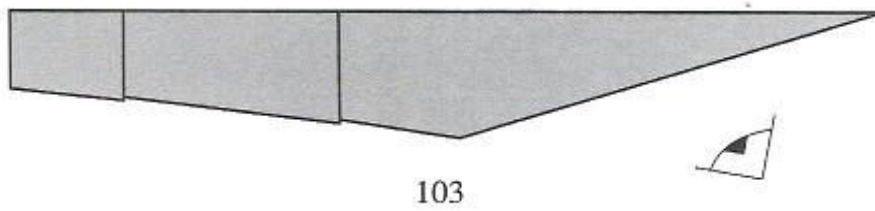
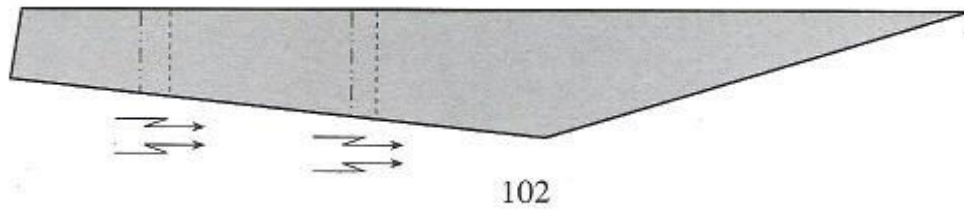
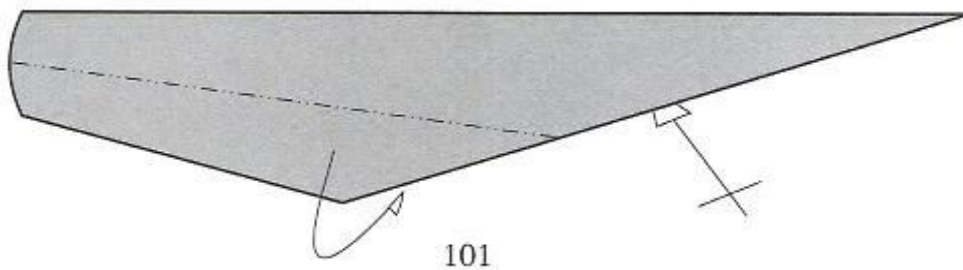

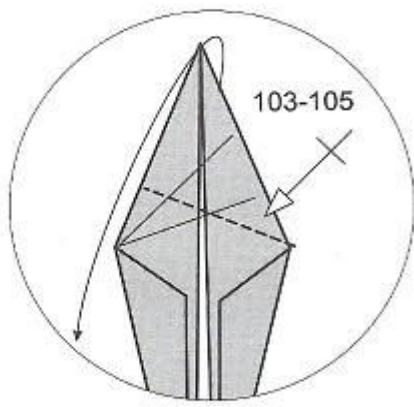

107

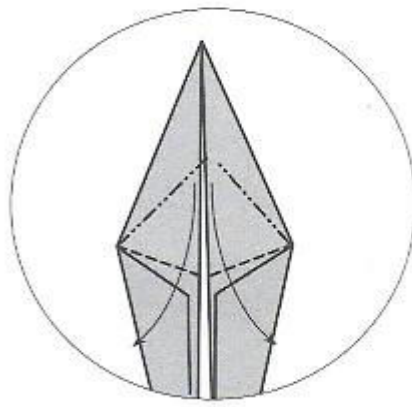

108

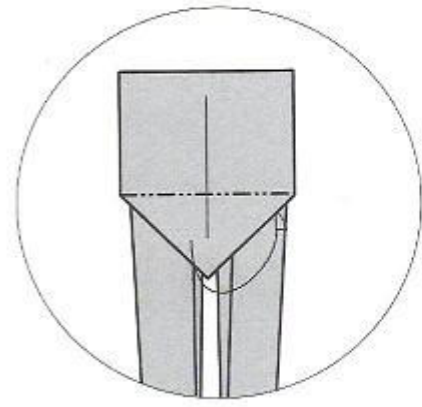

109

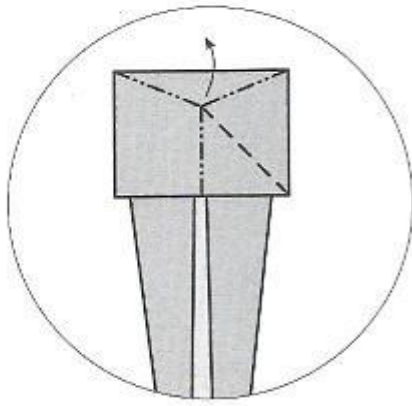

110

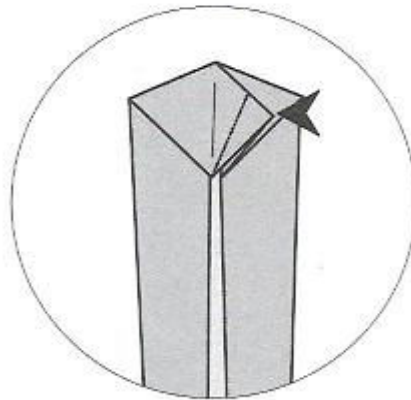

111

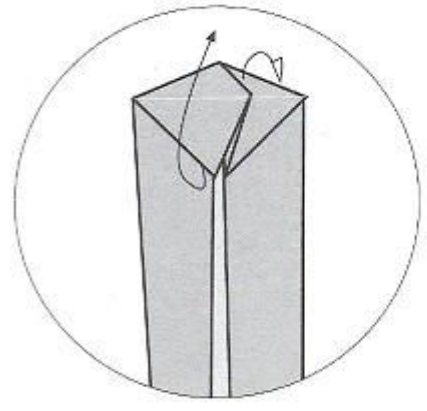

112

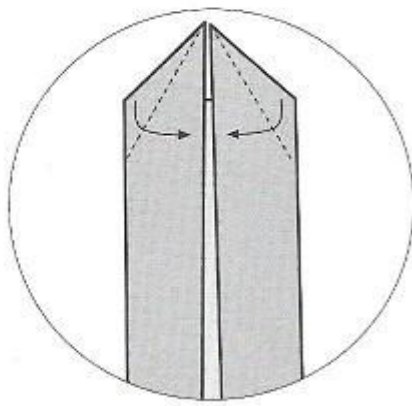

113

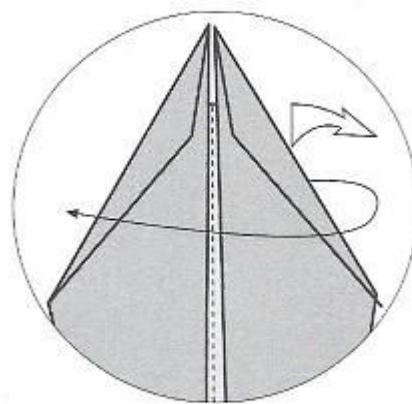

114

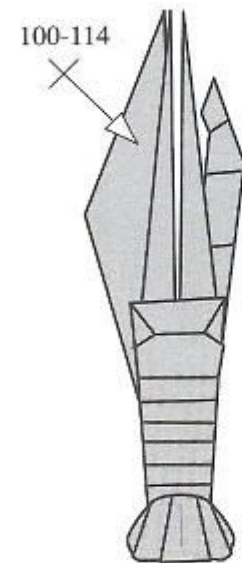

115

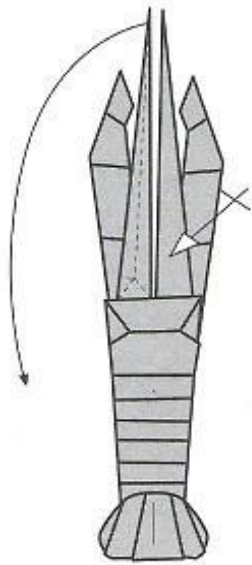

116

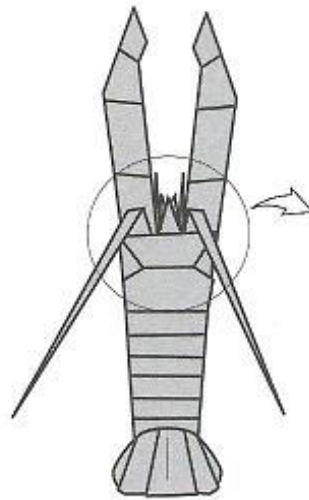

117

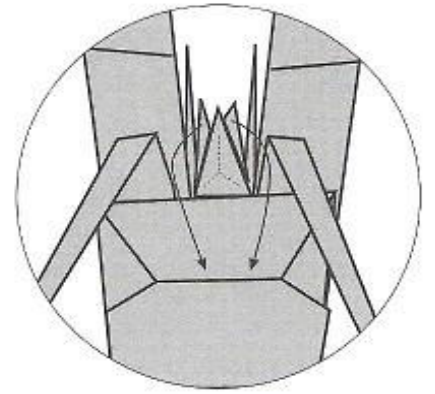

118

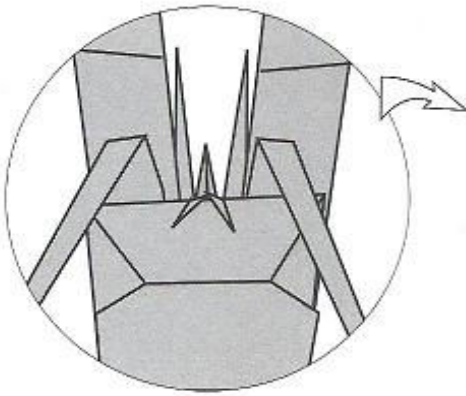

119

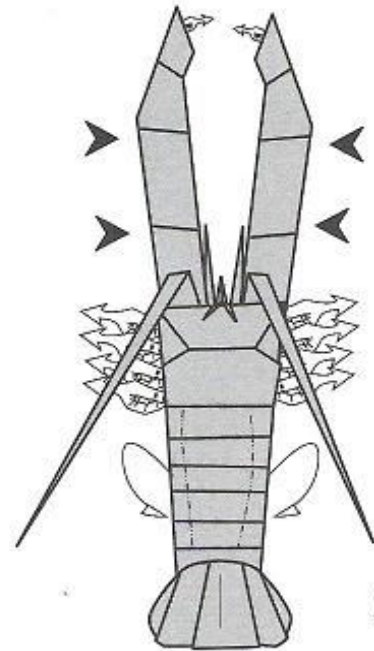

120

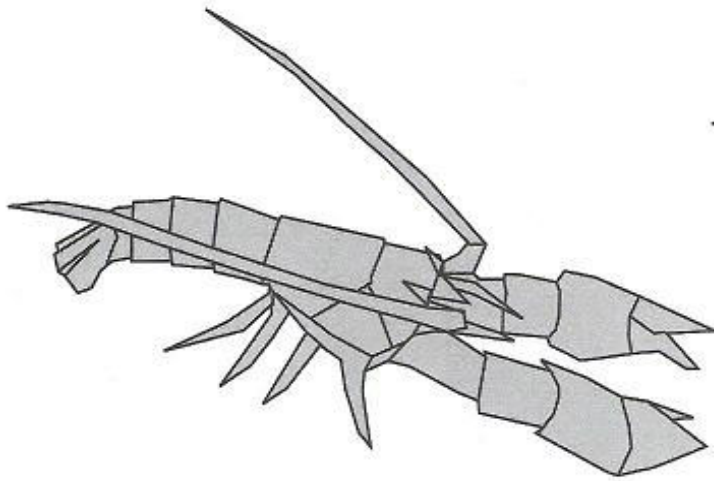

121

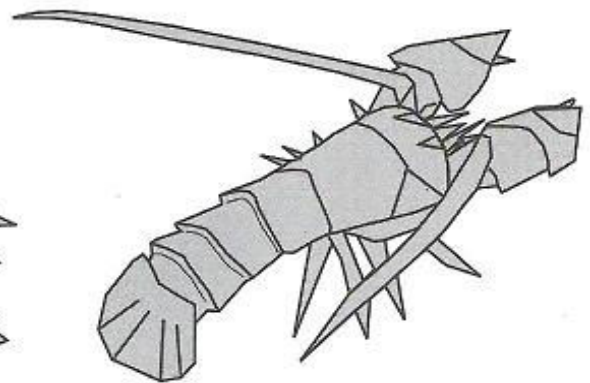

180

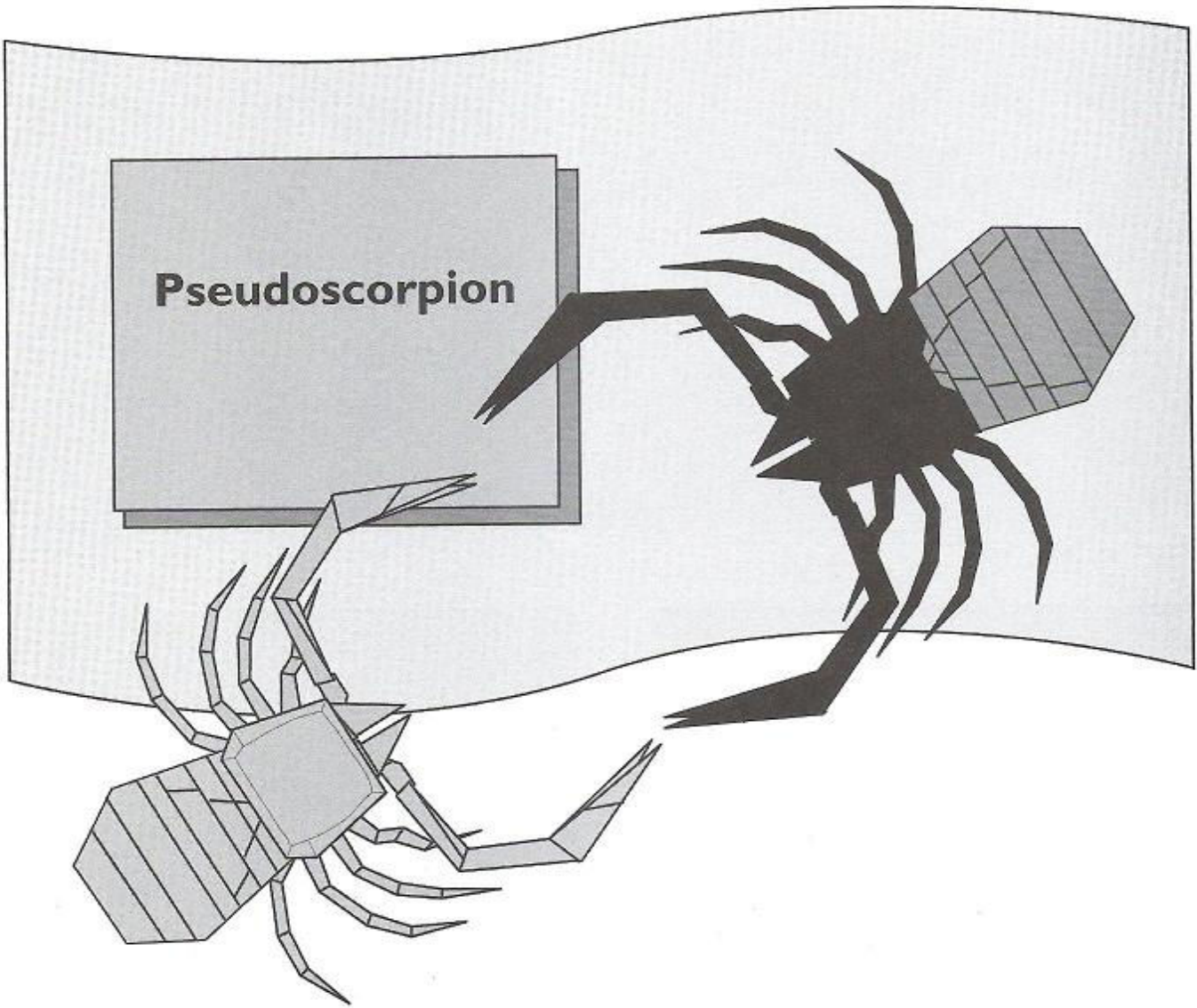

The paper should be brown. Fine paper is recommended, less than 30 grams, double silk, or "sandwich," 9.8x9.8 inches (25x25 cm) or bigger.

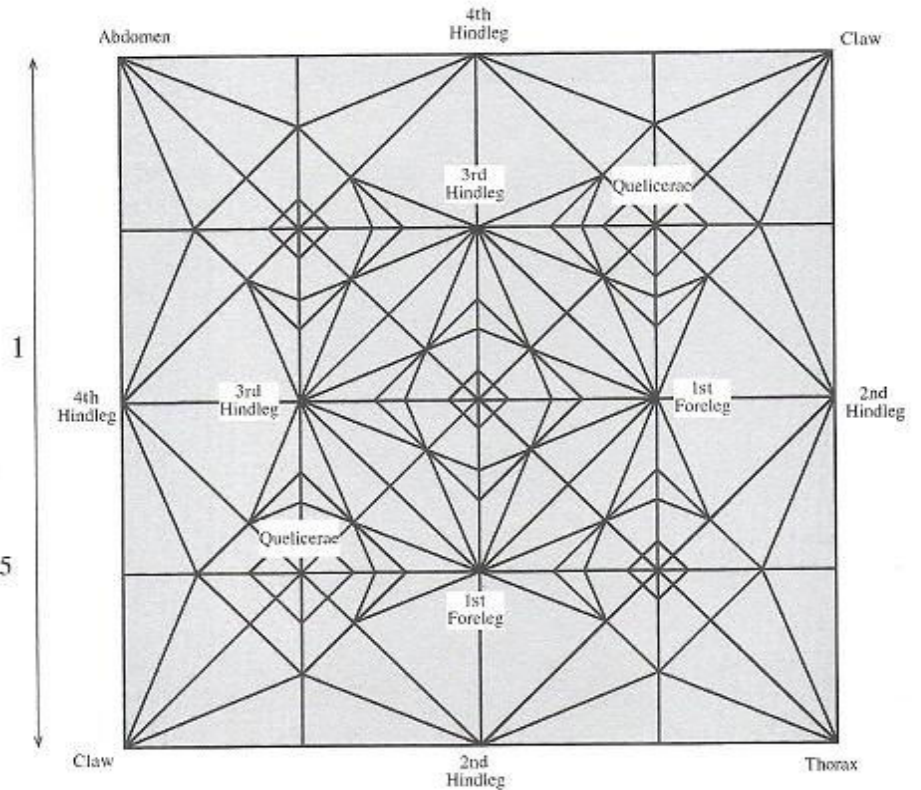
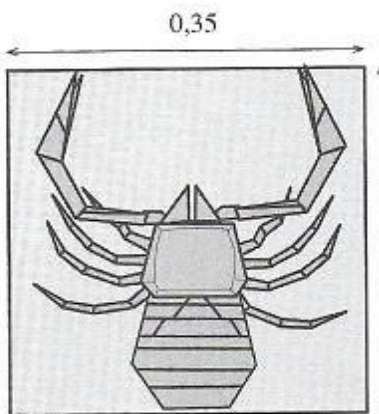

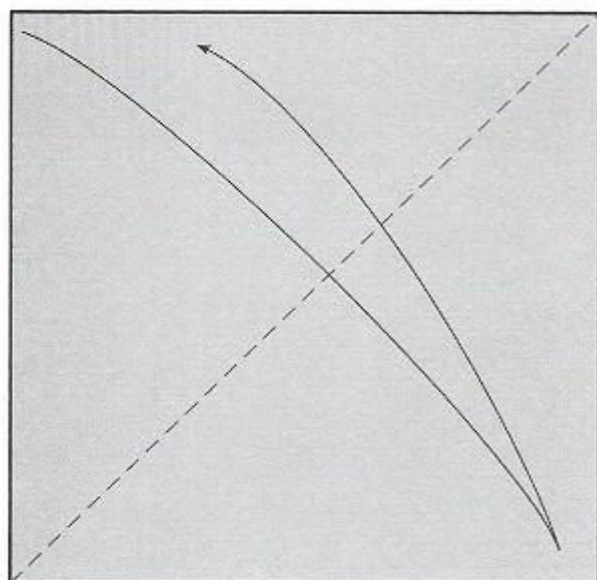

1 ● black brown ● green any color

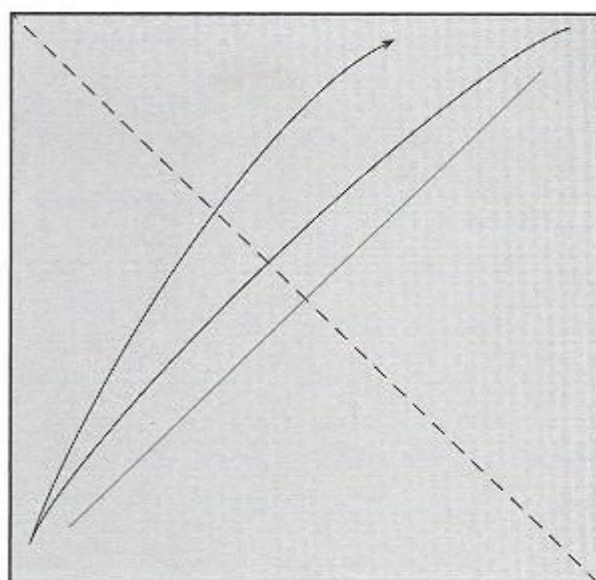

2

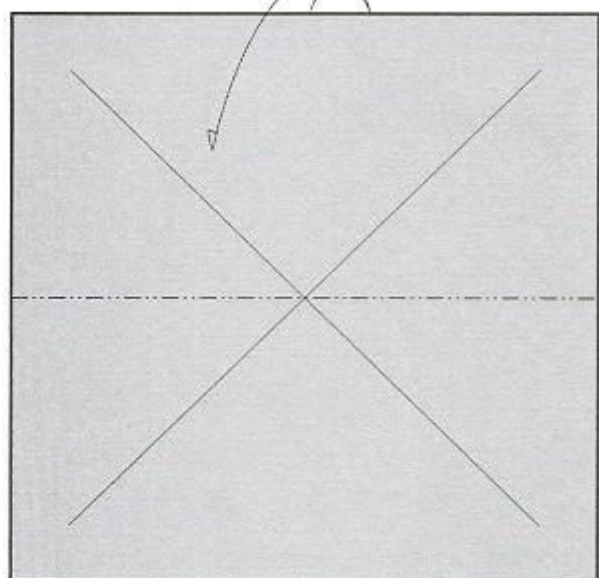

3

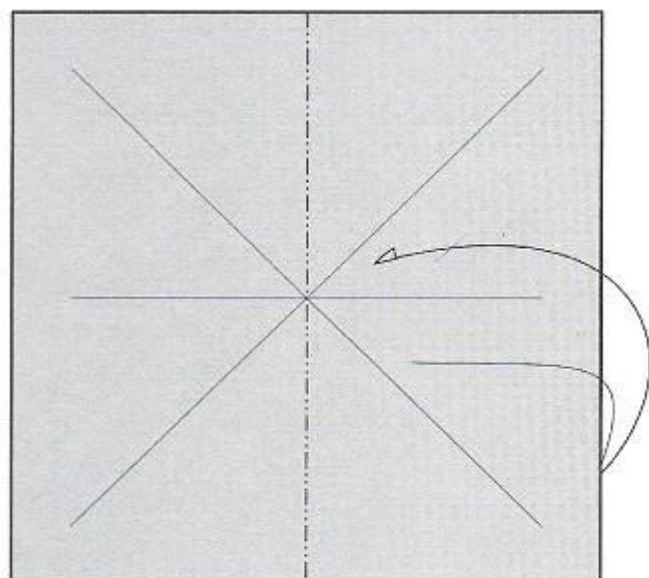

4

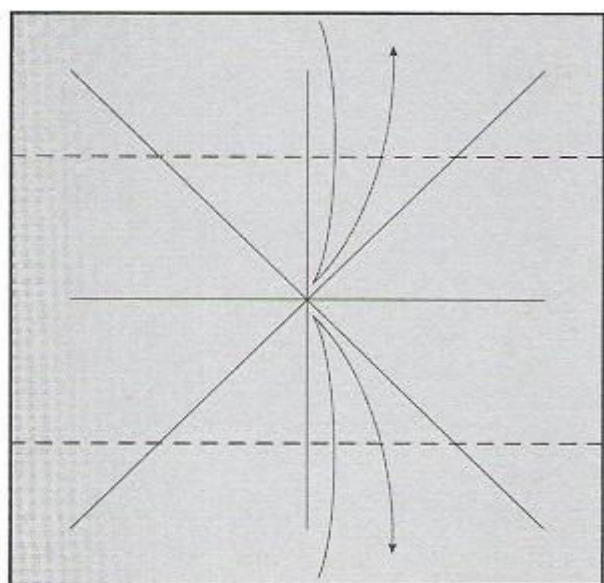

5

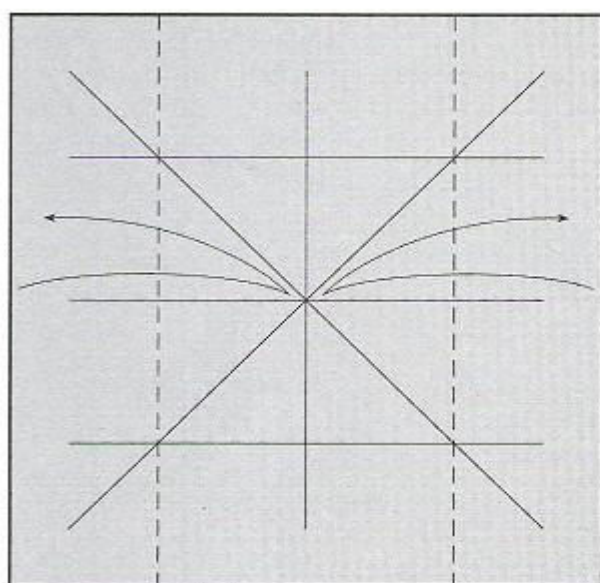

6

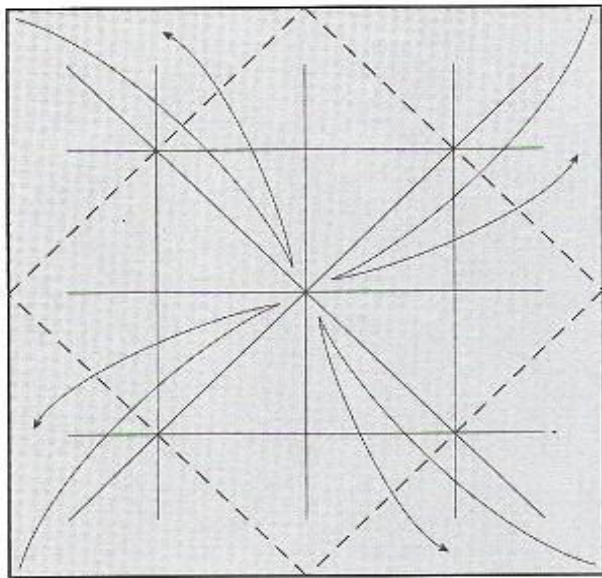

7

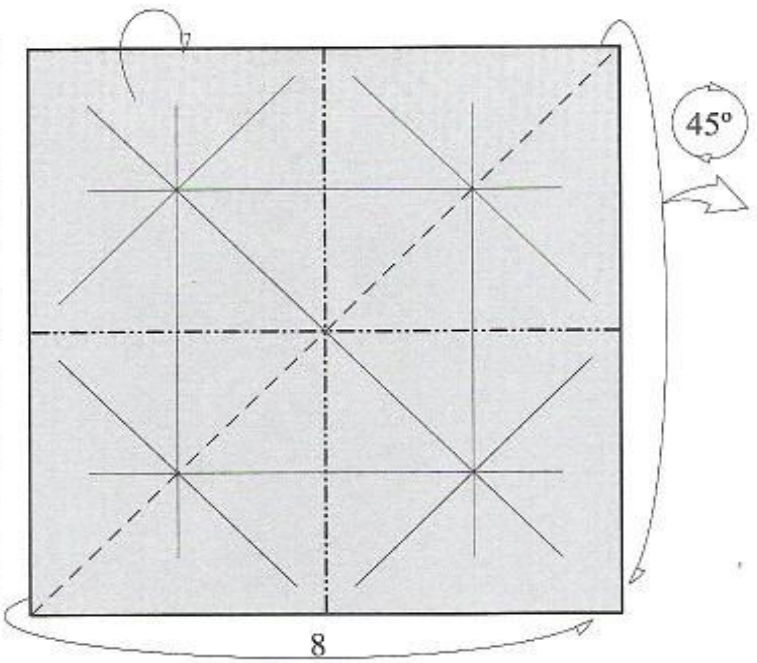

8

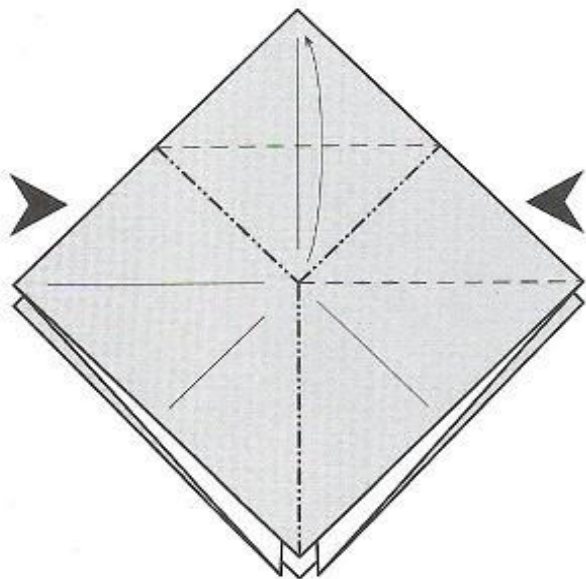

9

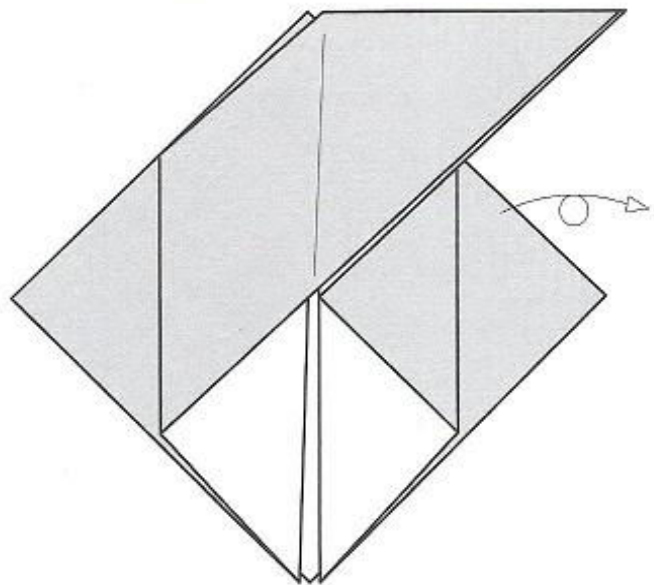

10

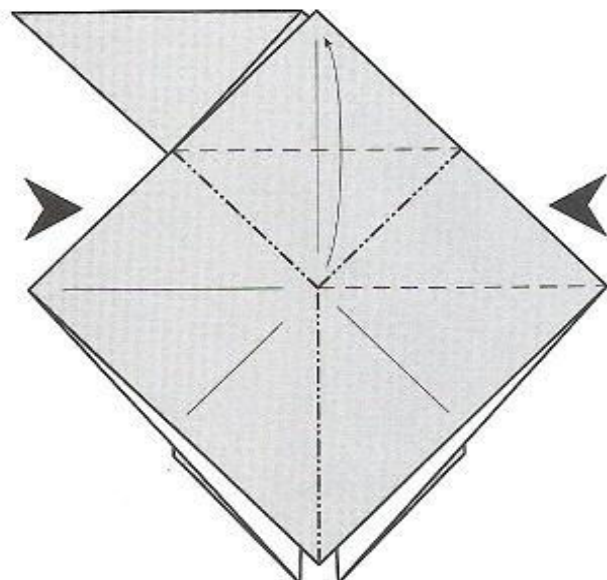

11

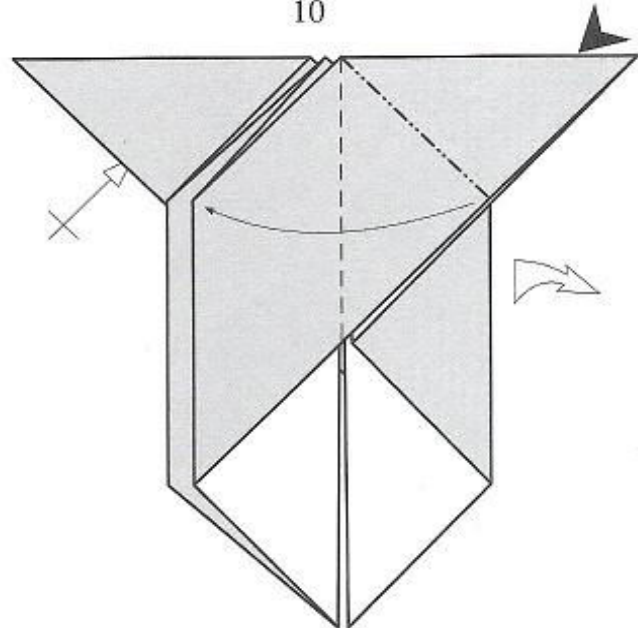

12

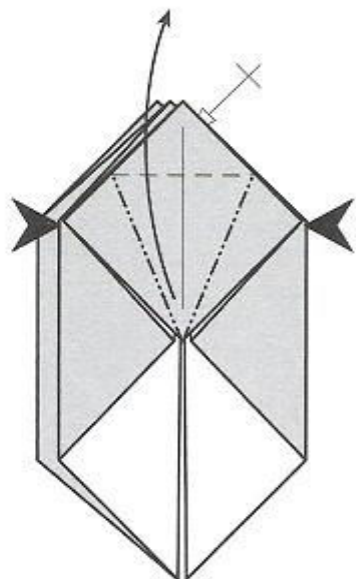

13

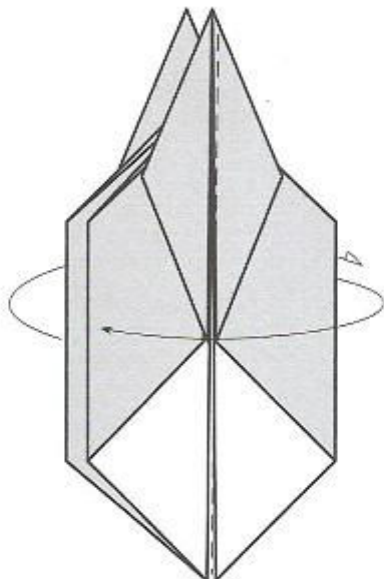

14

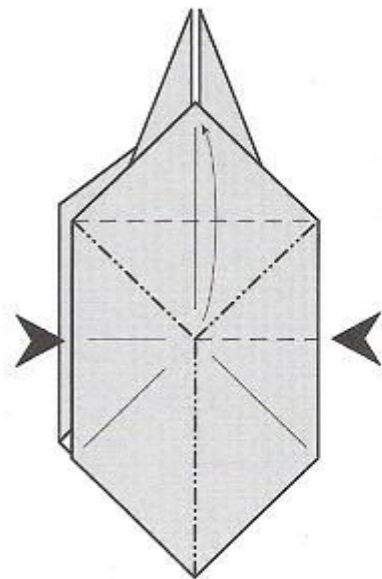

15

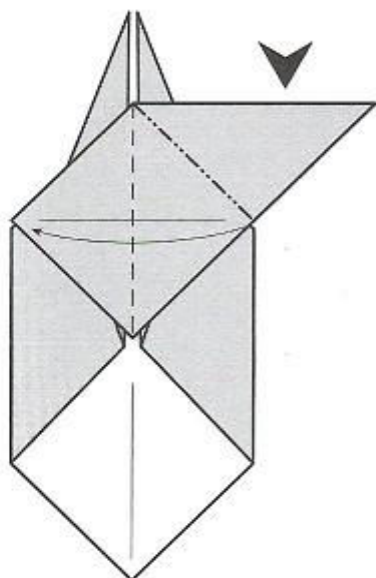

16

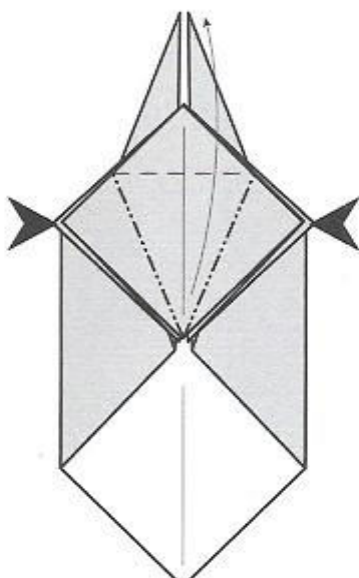

17

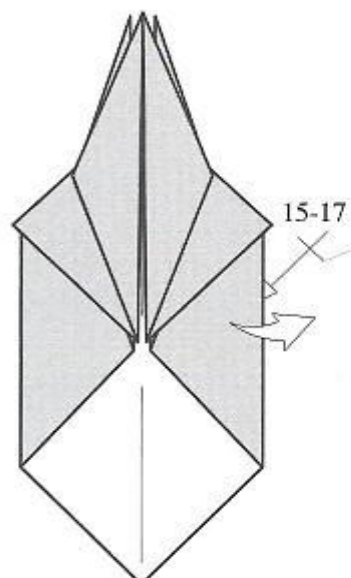

18

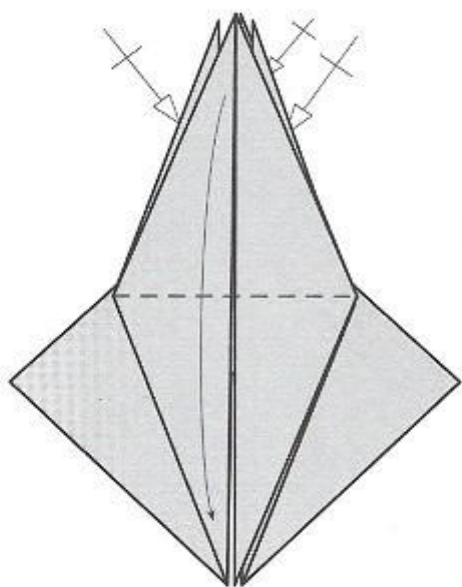

19

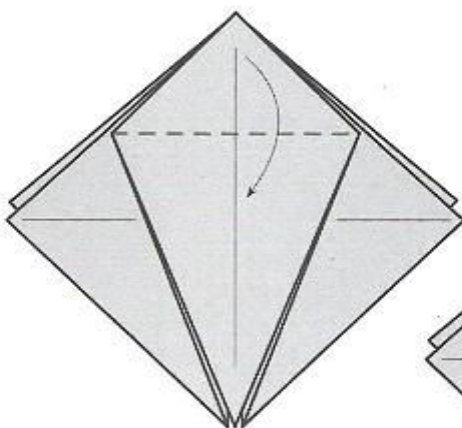

20

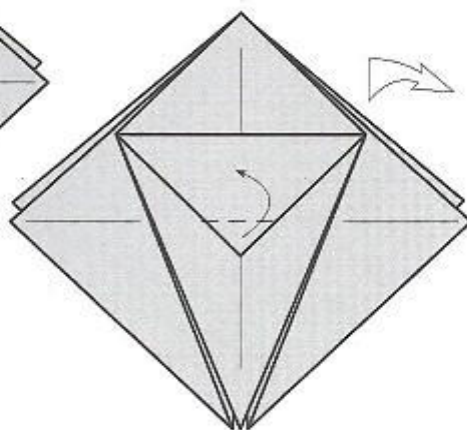

21

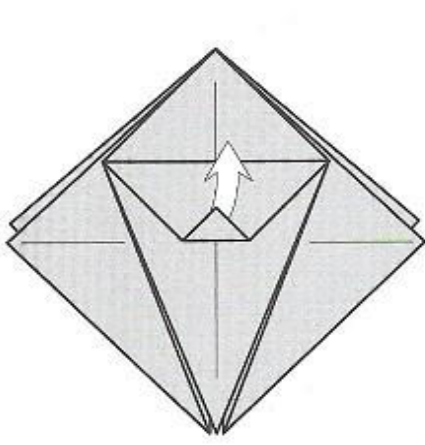

22

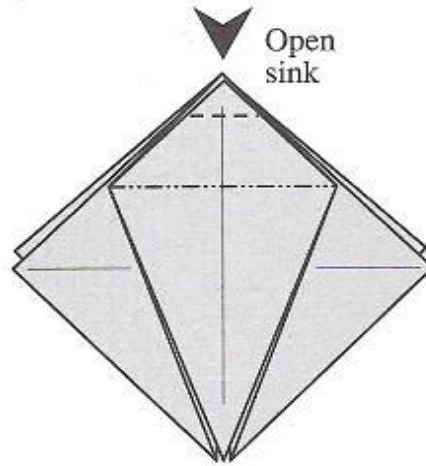

23

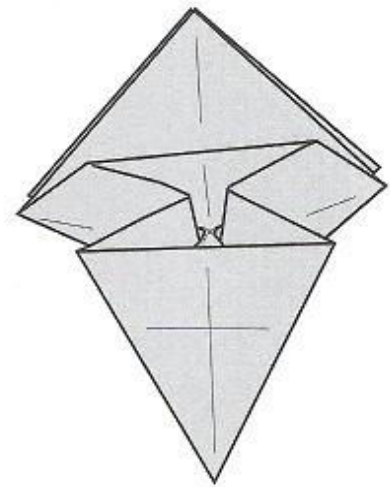

24-3D

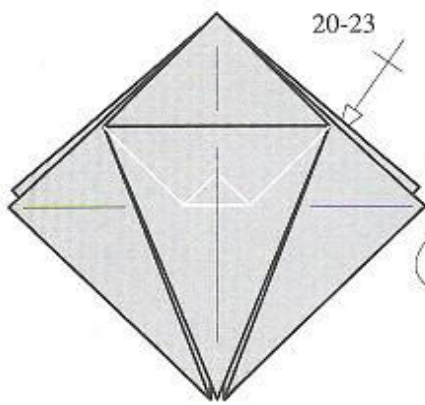

25 R-X

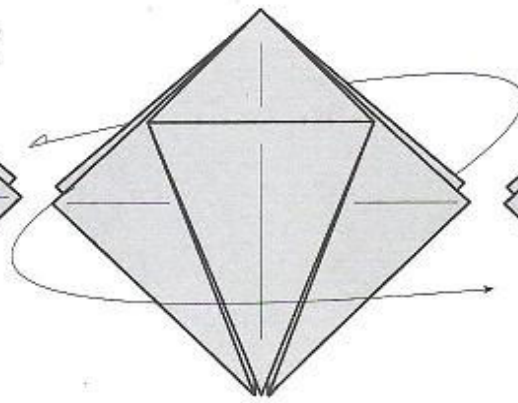

26

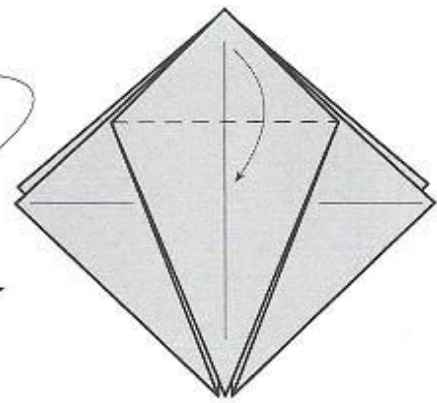

27

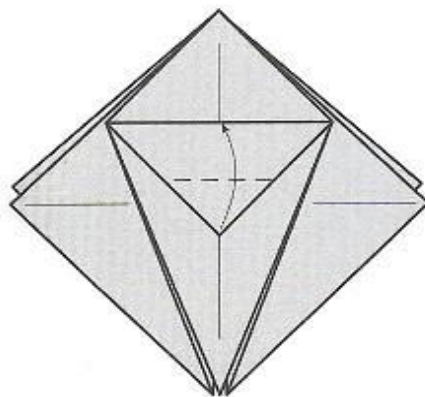

28

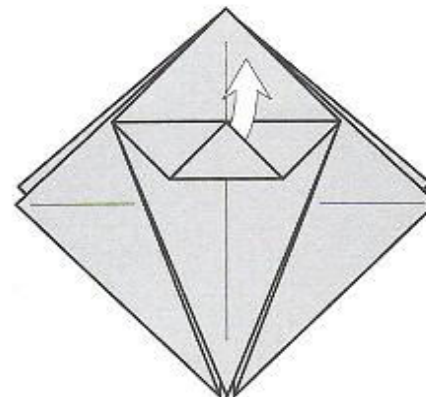

29

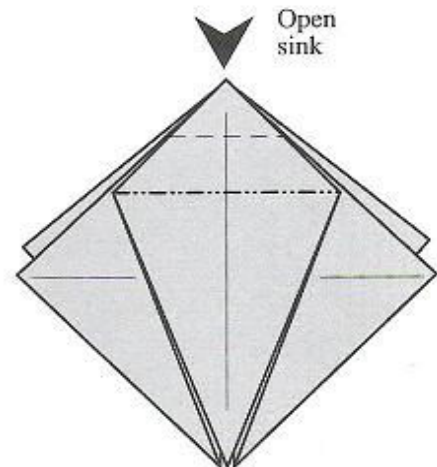

30

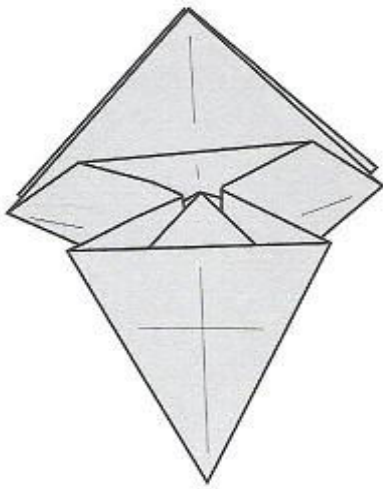

31-3D

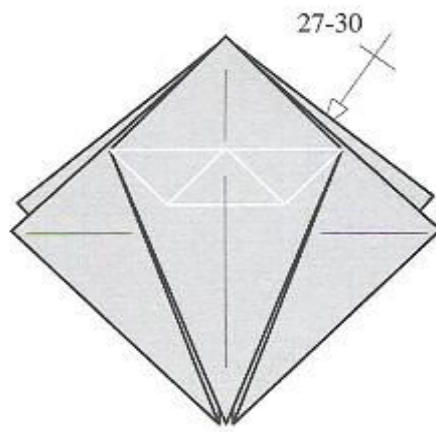

32 R-X

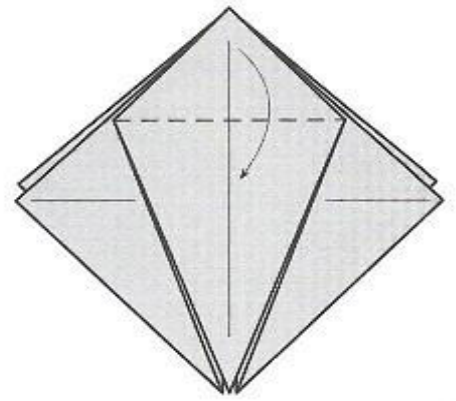

33

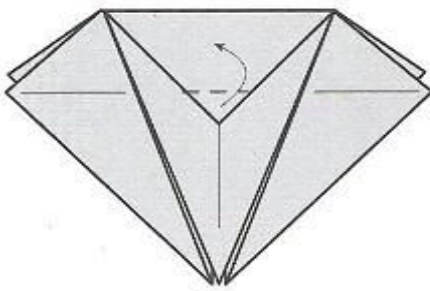

34

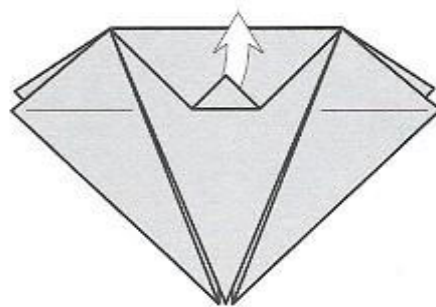

35

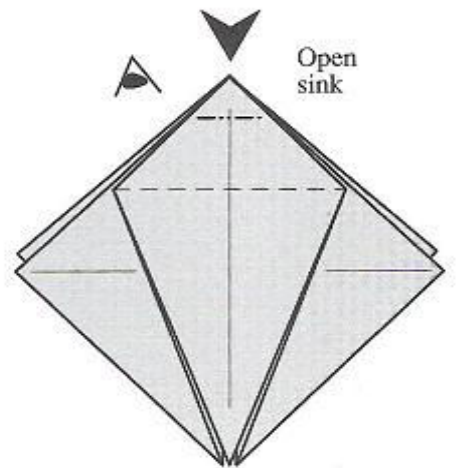

36

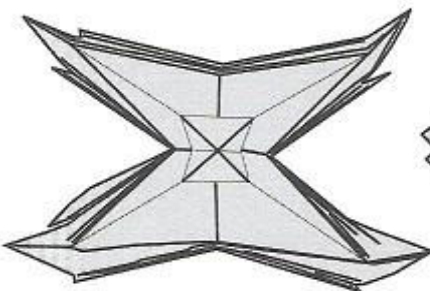

37-3D

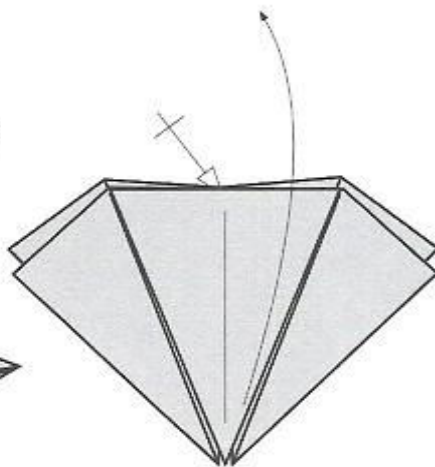

38

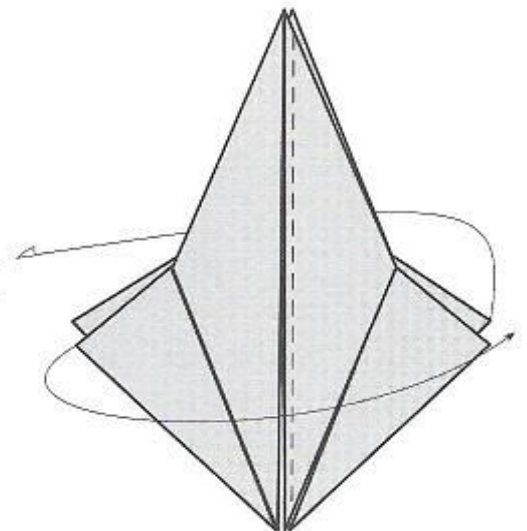

39

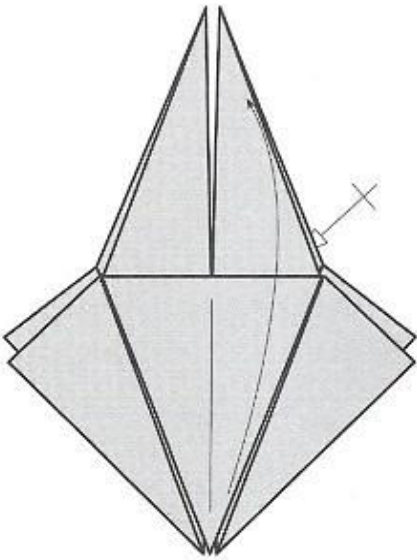

40

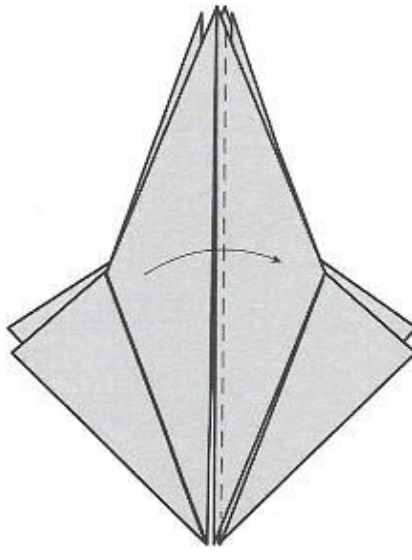

41

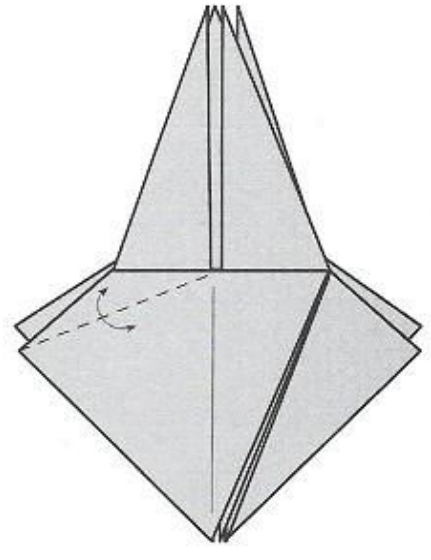

42

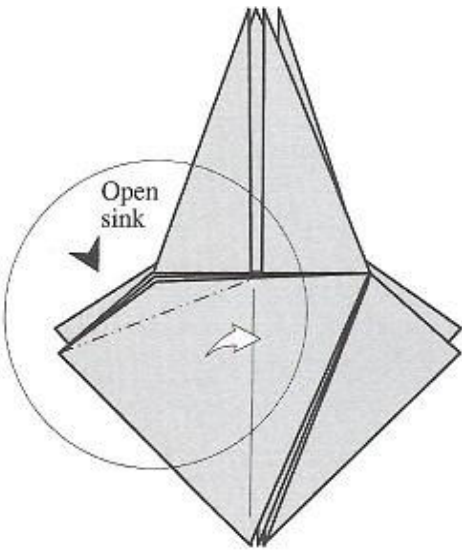

43

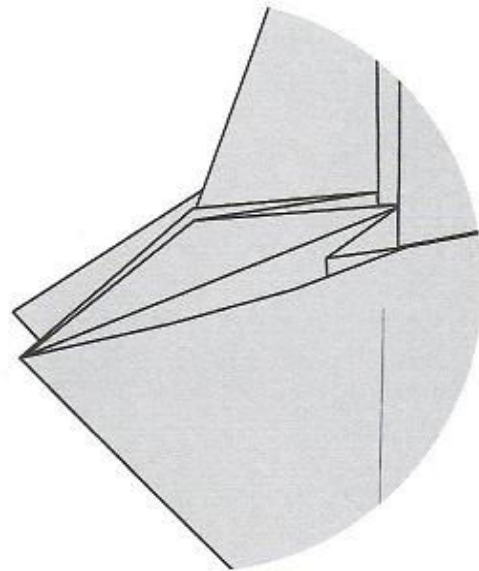

44

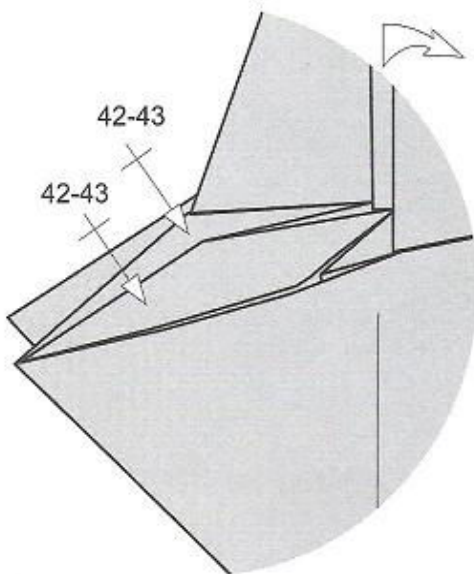

45

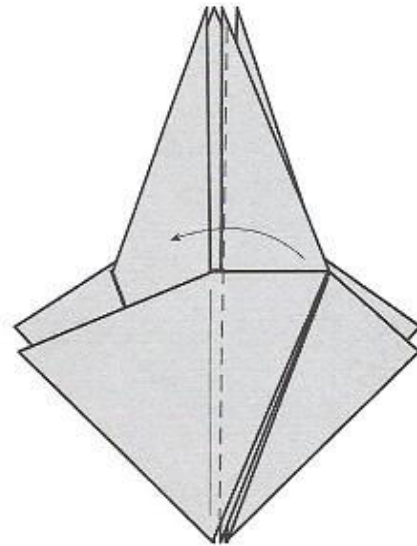

46

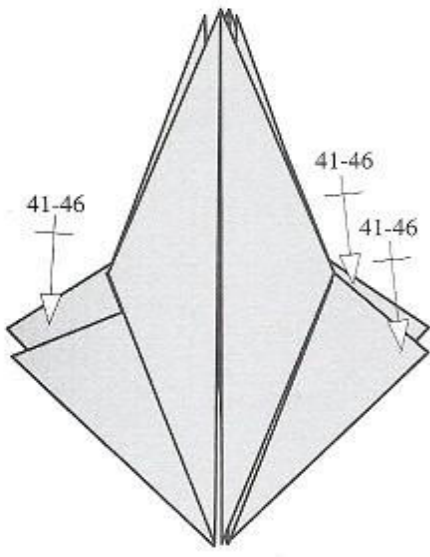

47

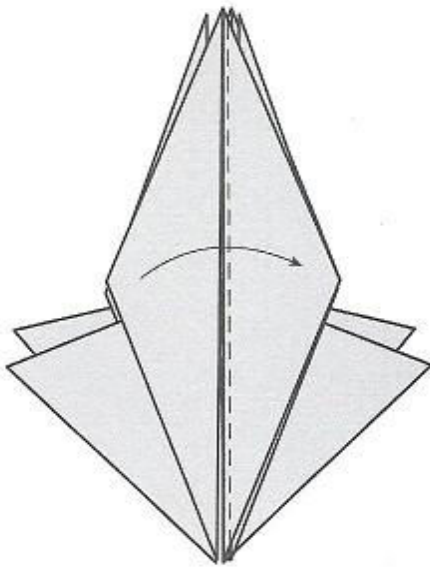

48

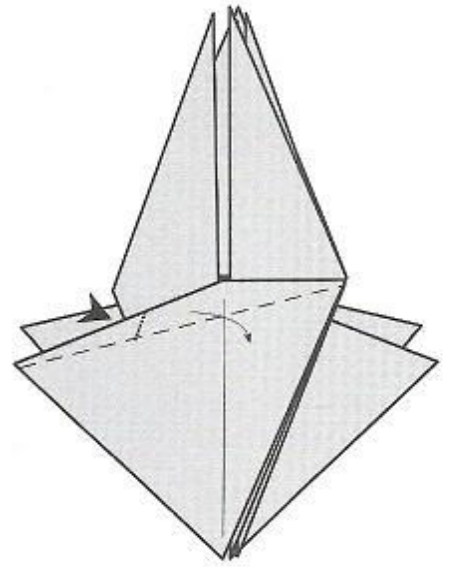

49

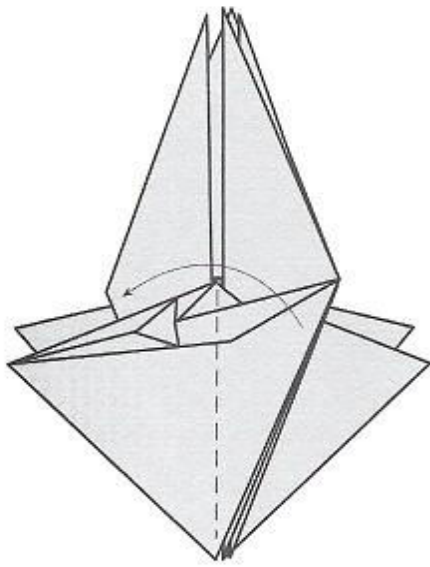

50

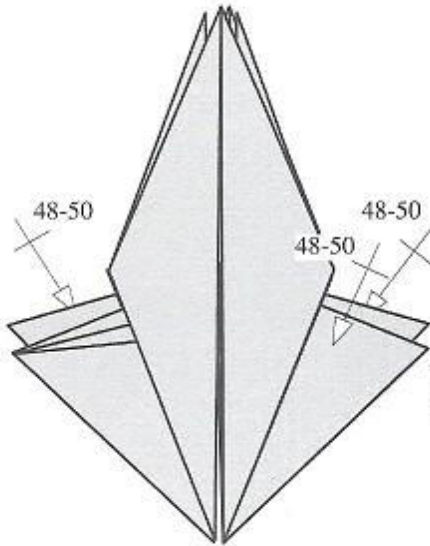

51

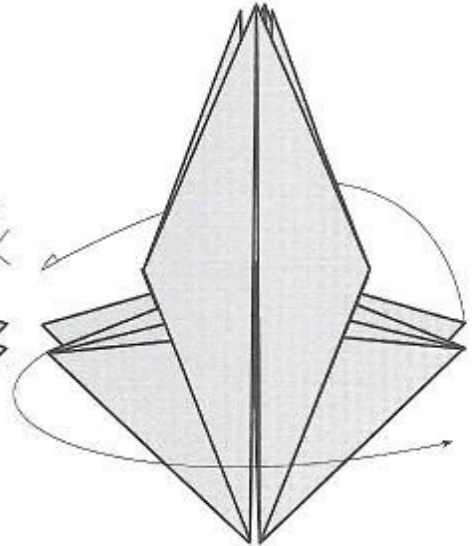

52

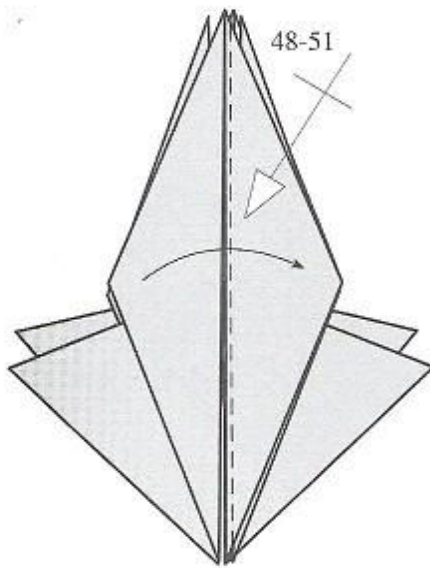

53

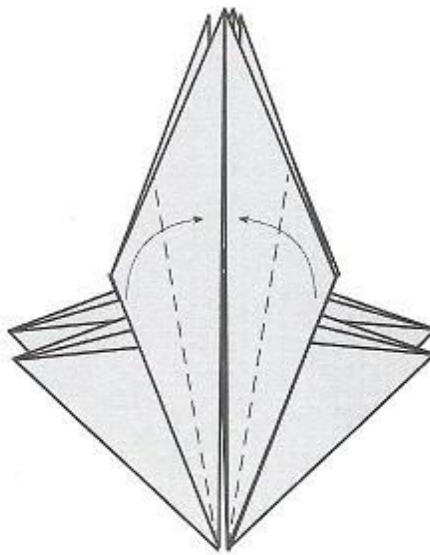

54

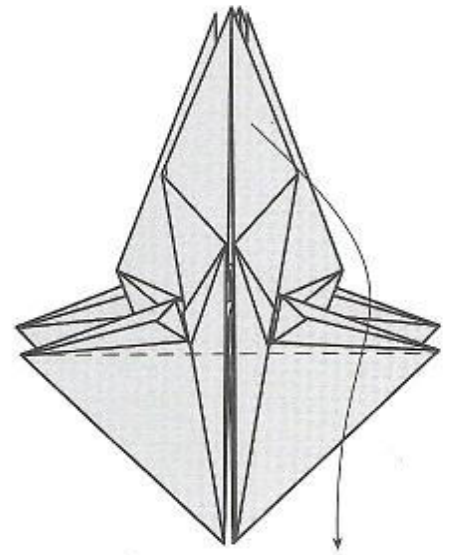

55

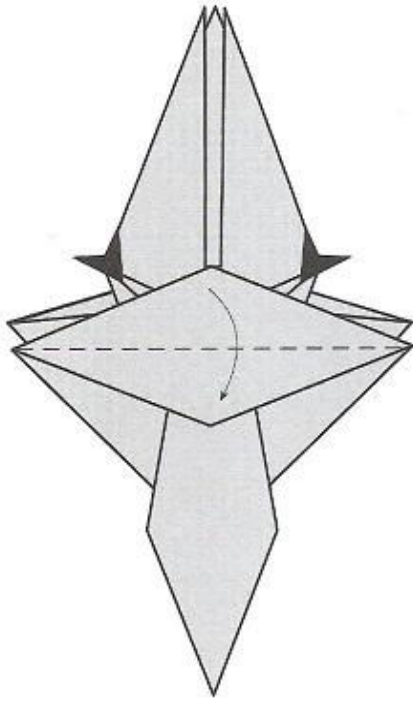

56

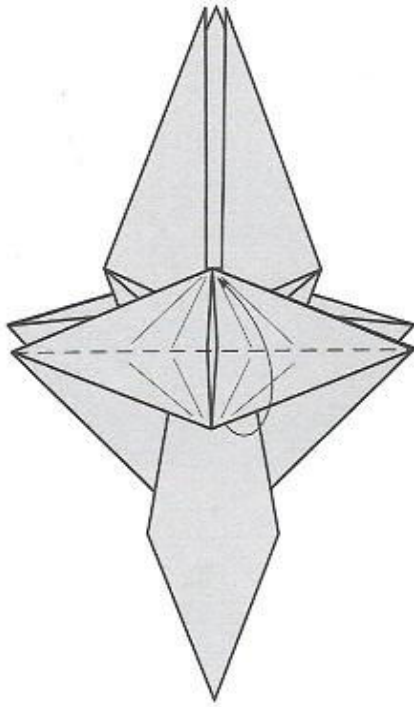

57

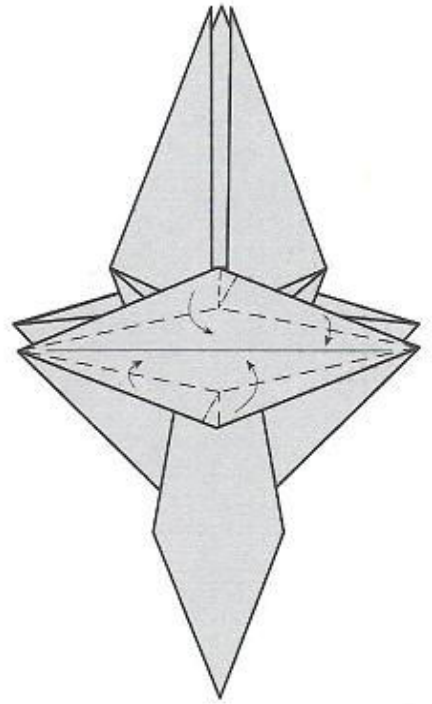

58

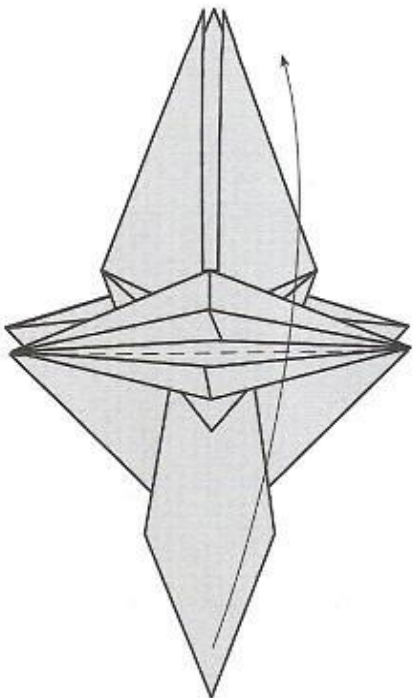

59

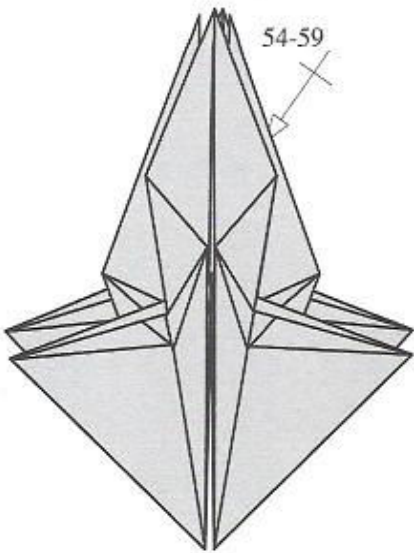

60

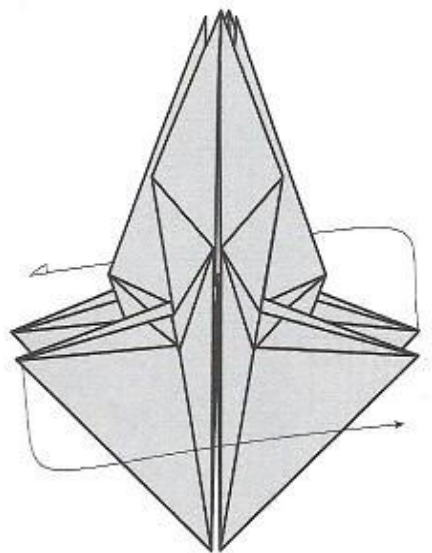

61

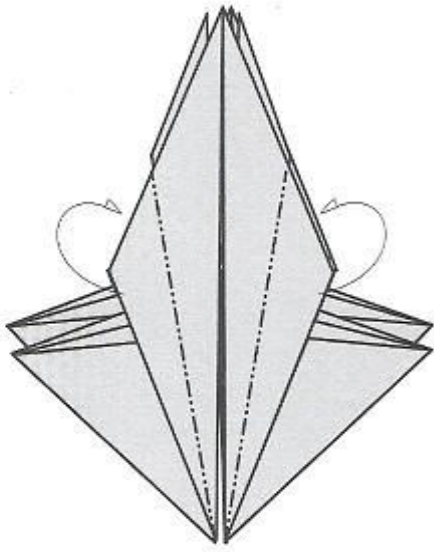

62

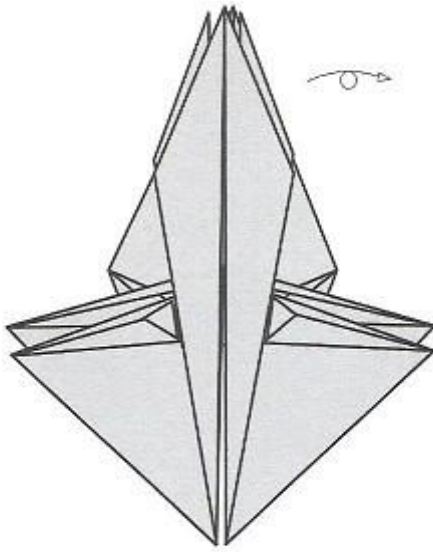

63

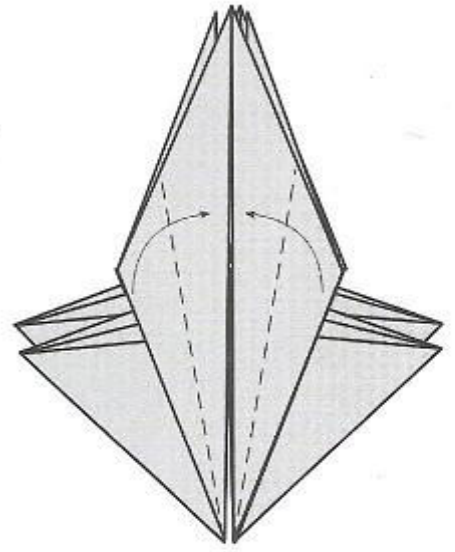

64

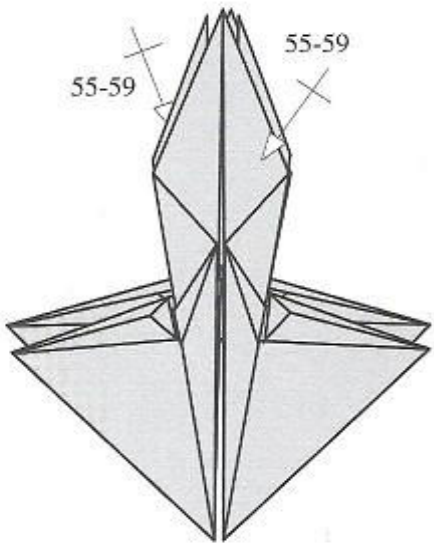

65

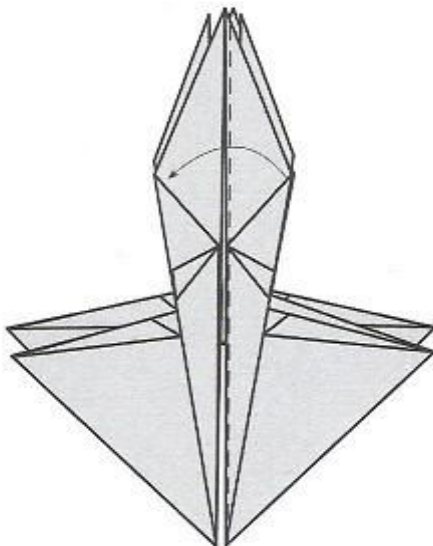

66

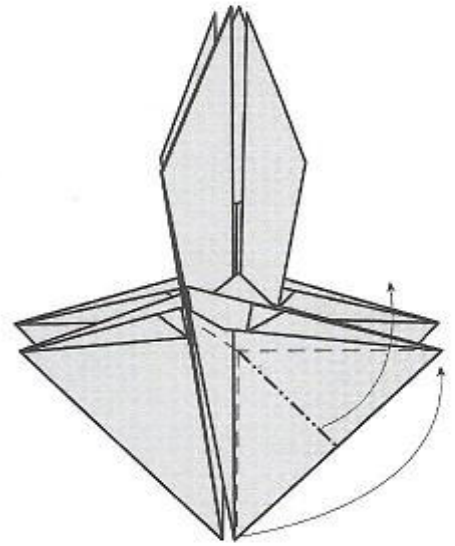

67

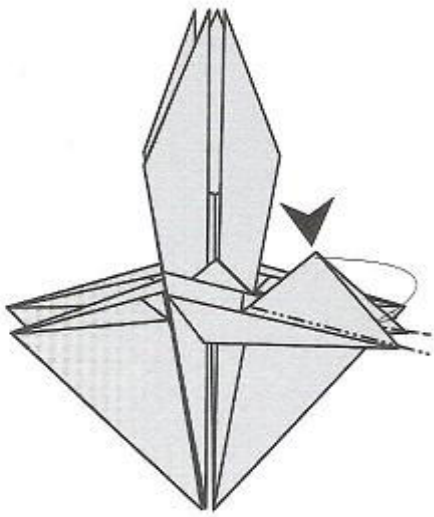

68

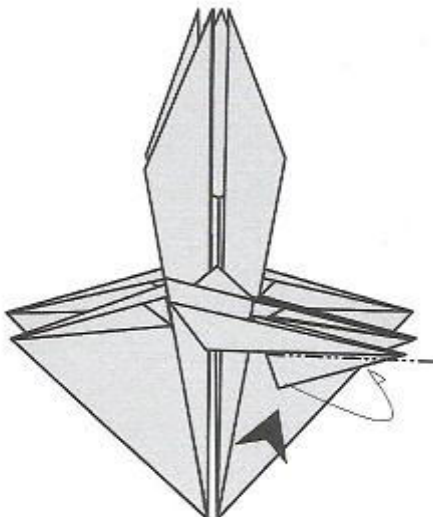

69

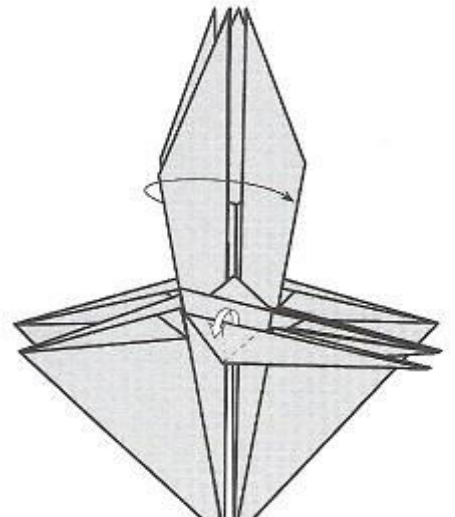

70

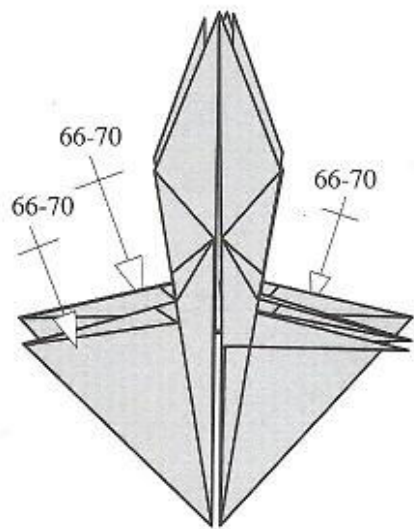

71

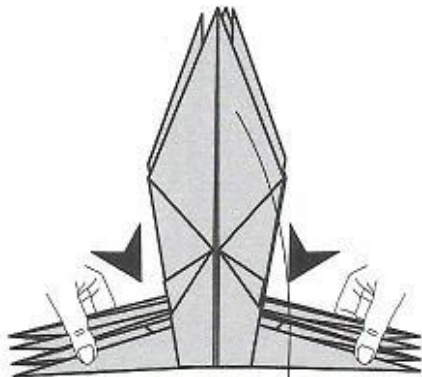

72

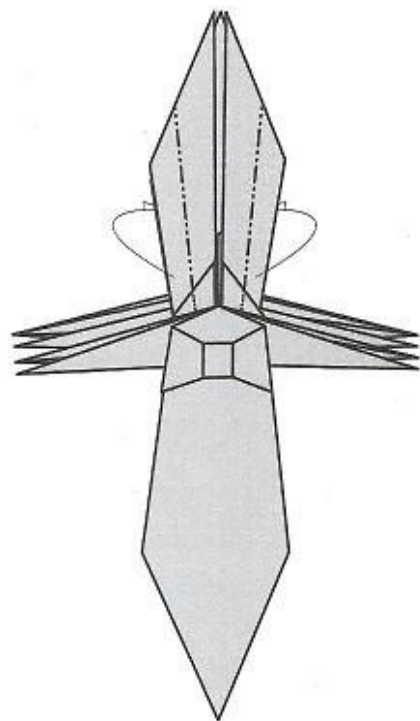

73

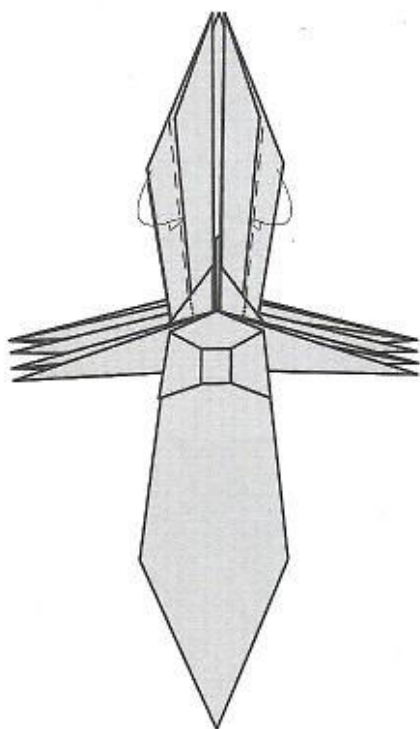

74

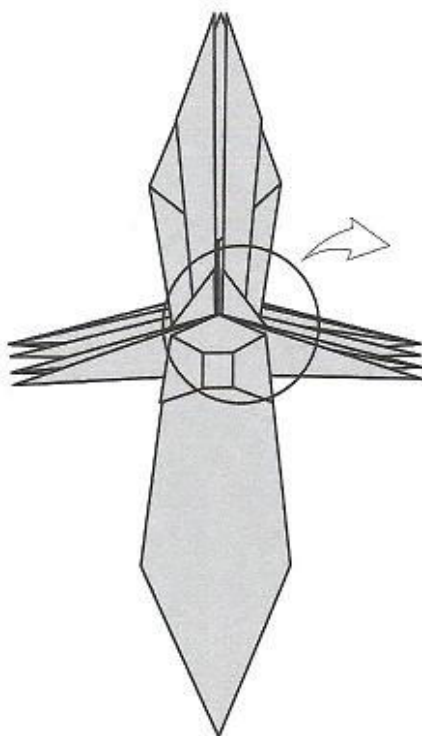

75

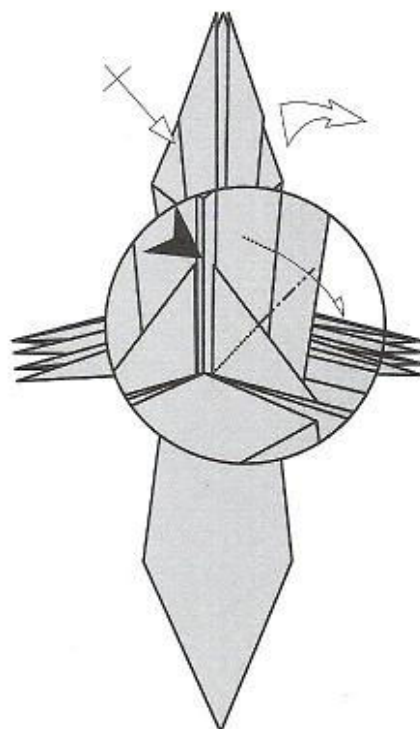

76

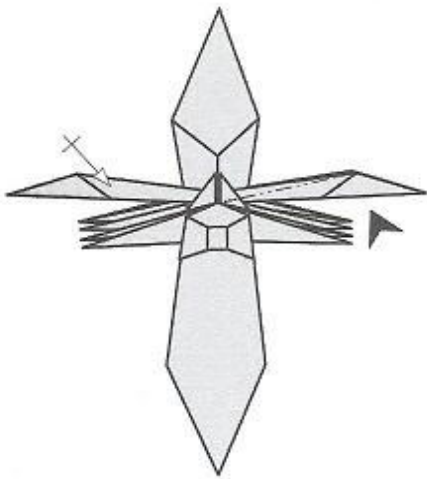

77

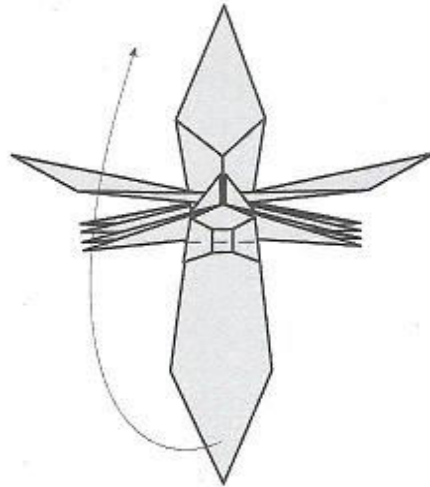

78

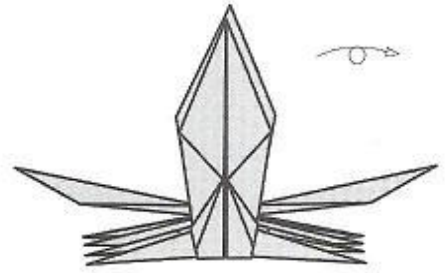

79

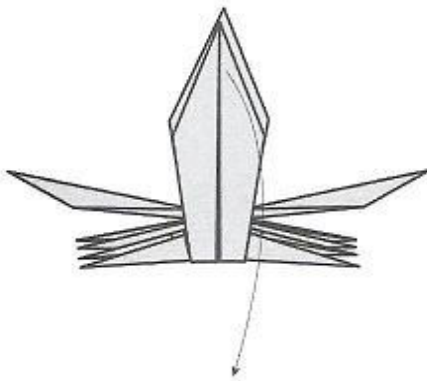

80

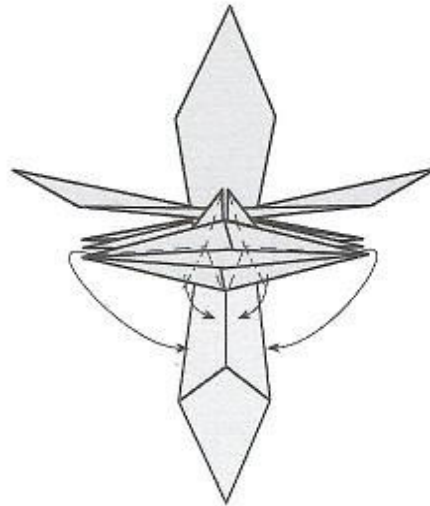

Rabbit ear for two tips

81

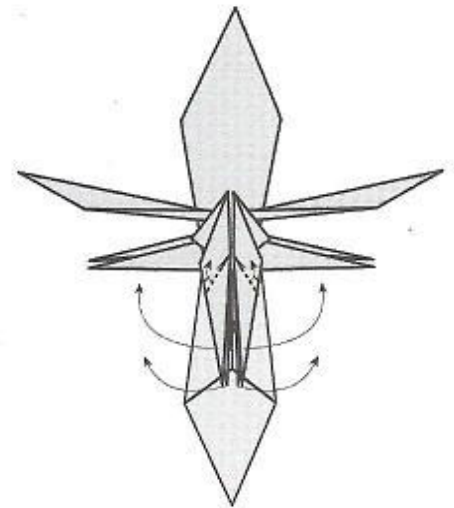

82

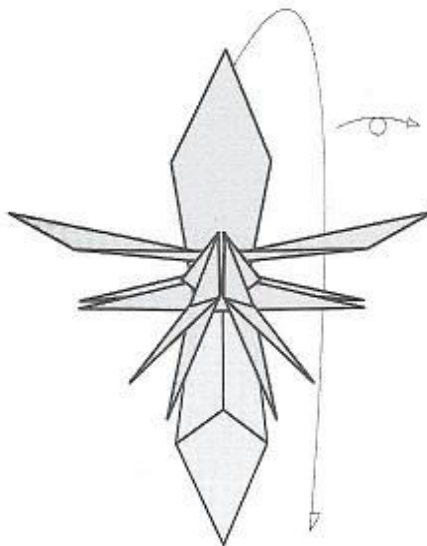

83

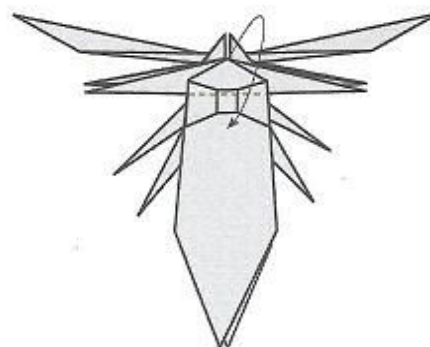

Two Layers

84

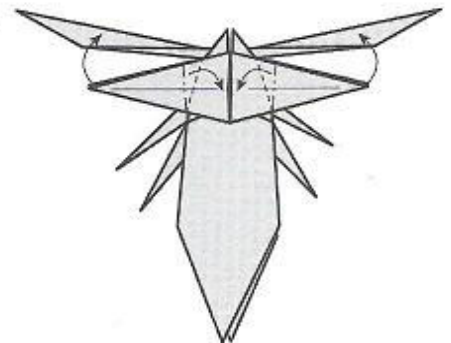

85

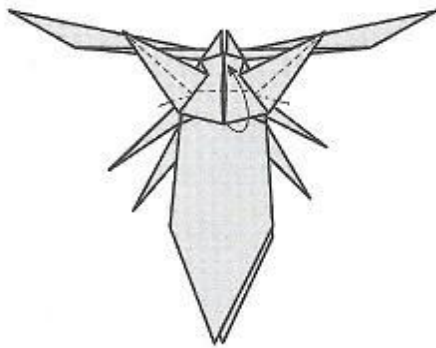

86

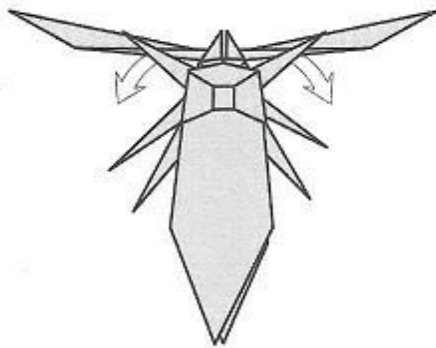

87

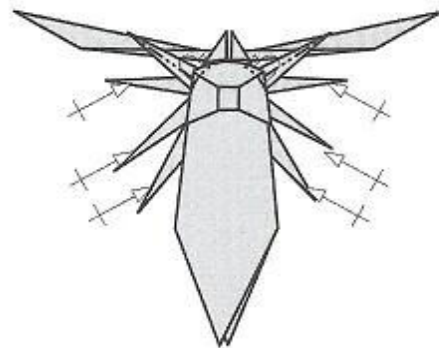

Rabbit ear in each leg

88

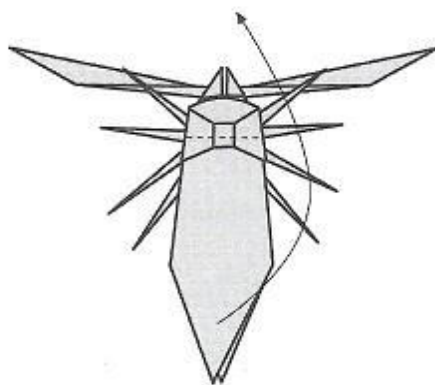

89

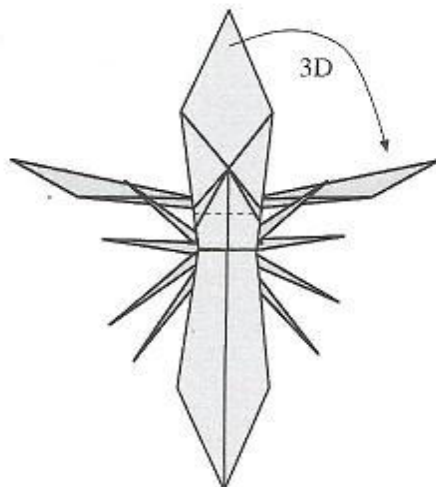

90

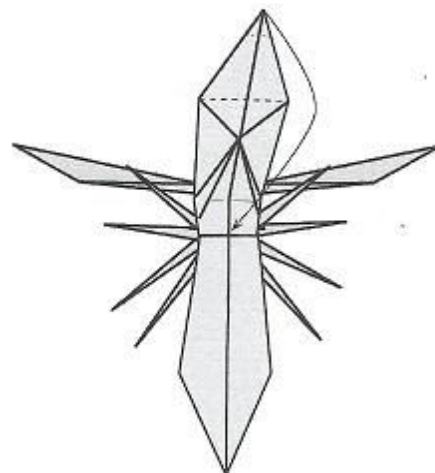

91

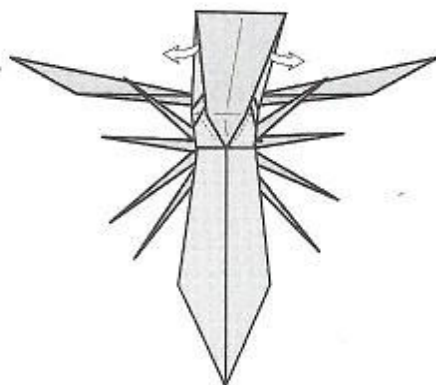

92

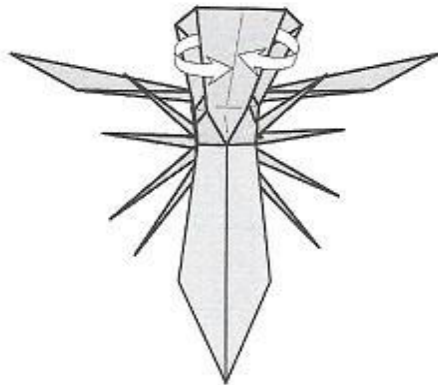

93

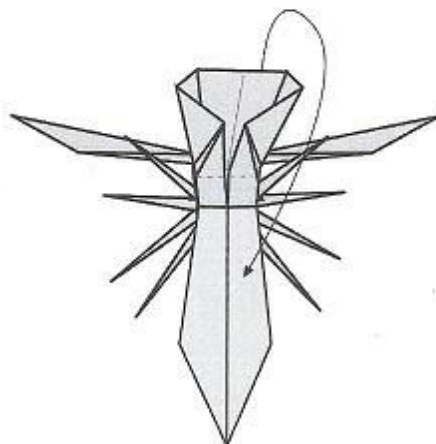

94

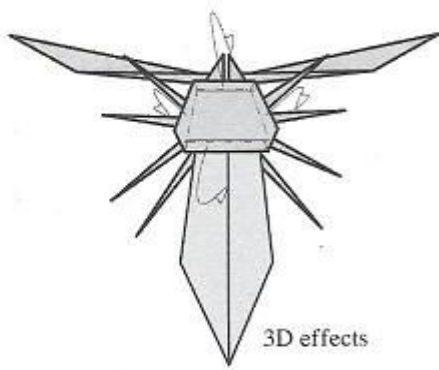

95

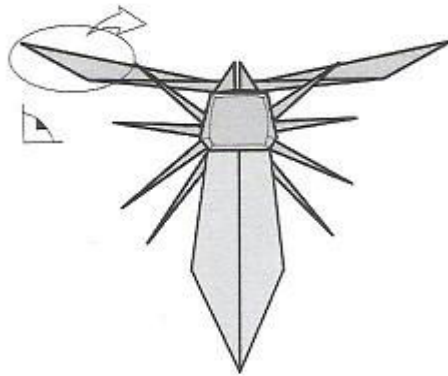

96

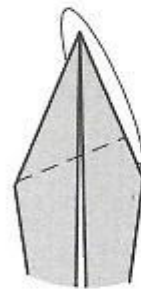

97



98



99

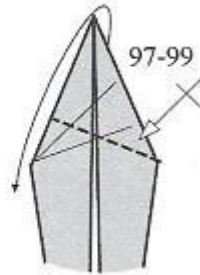

100

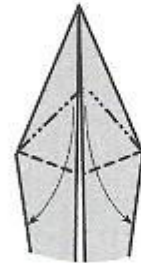

101



102



103



104



105



106



107

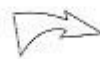

108

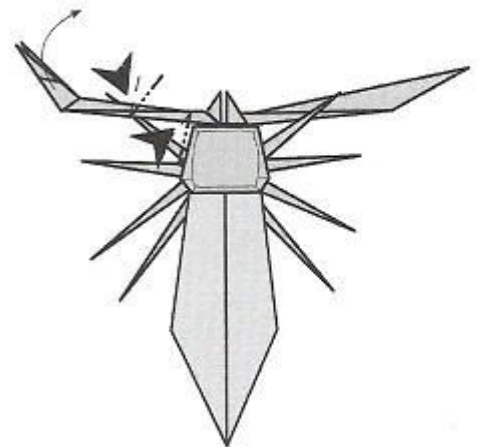

109

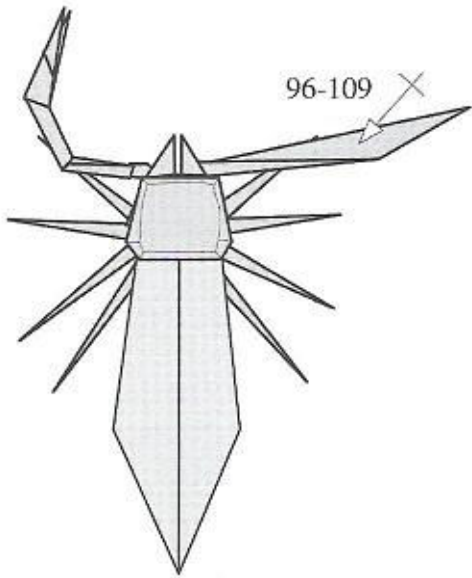

110

Monocolor version

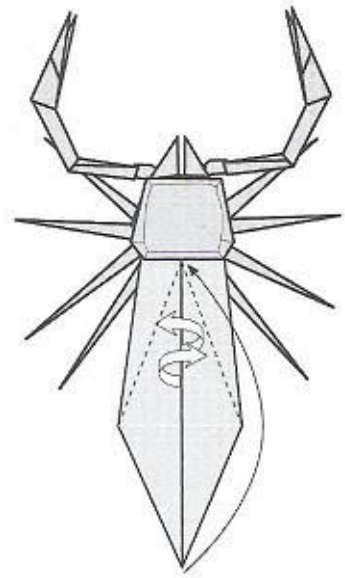

111

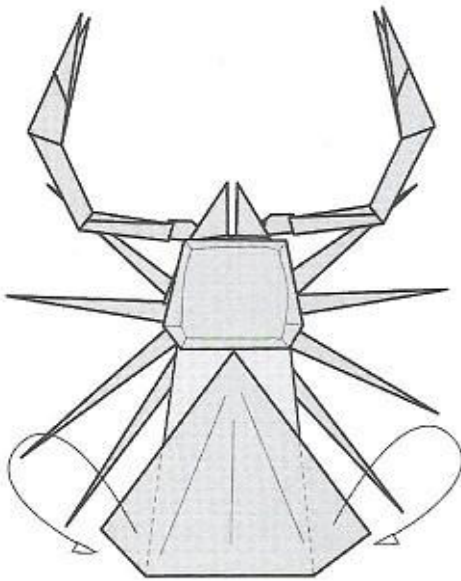

112

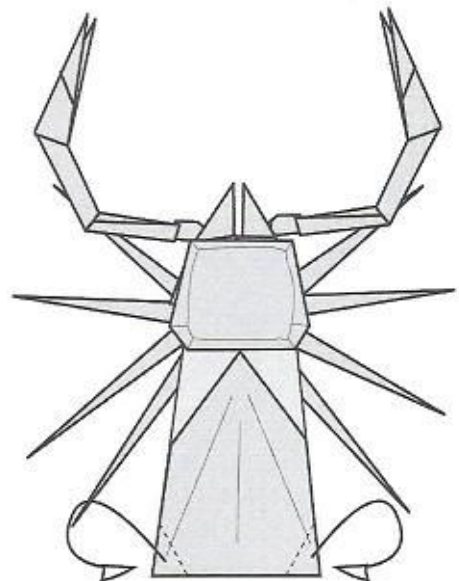

113

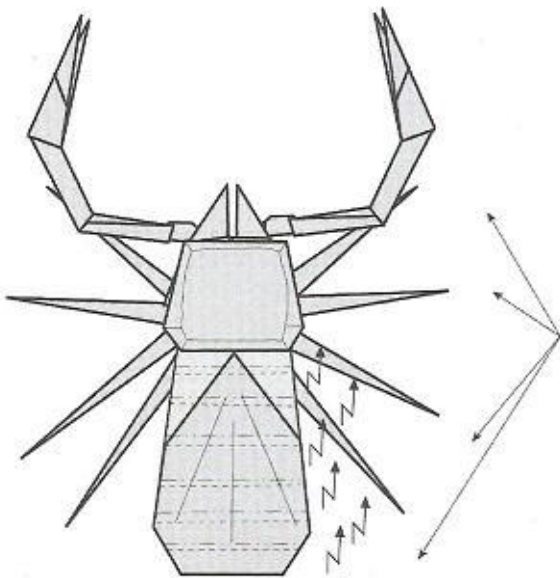

114

Make four segments
in the legs

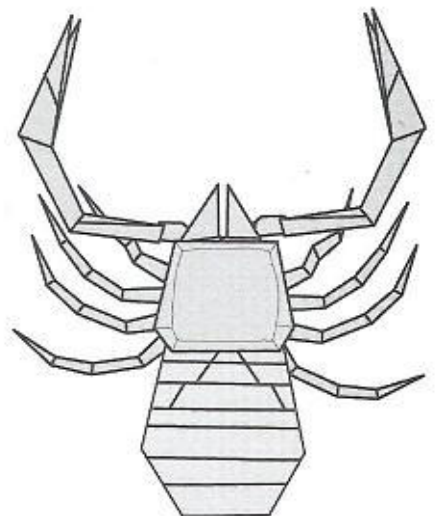

115

Bicolor version

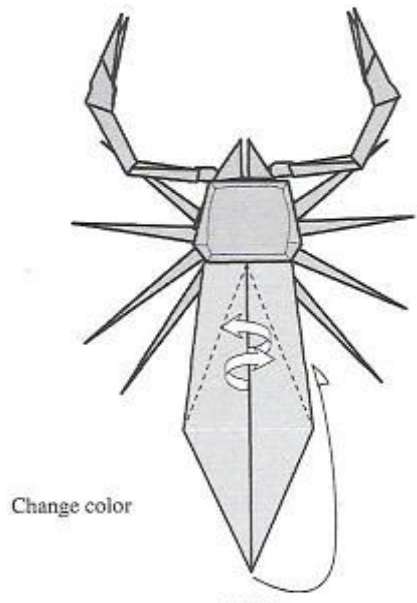

Change color

111

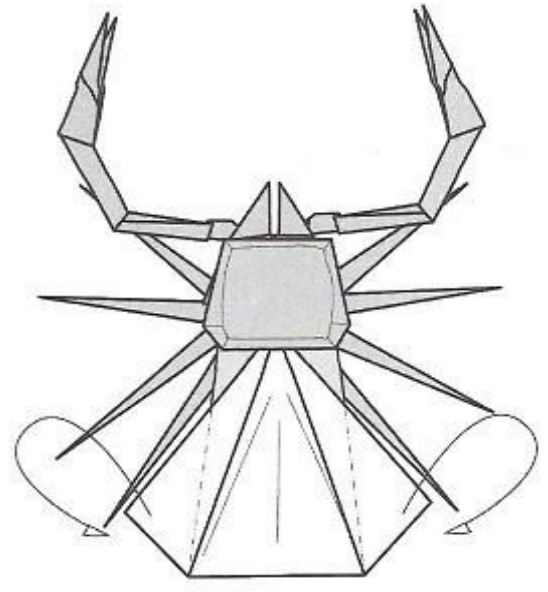

112

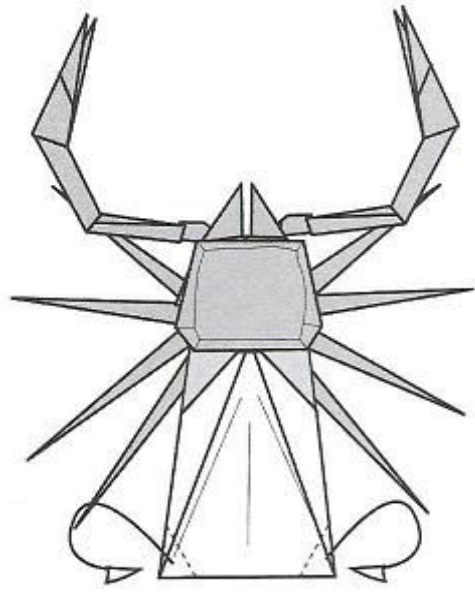

113

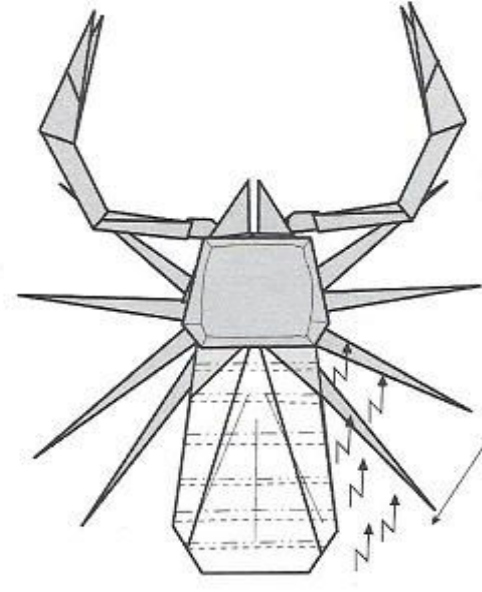

Make four segments in the legs

114

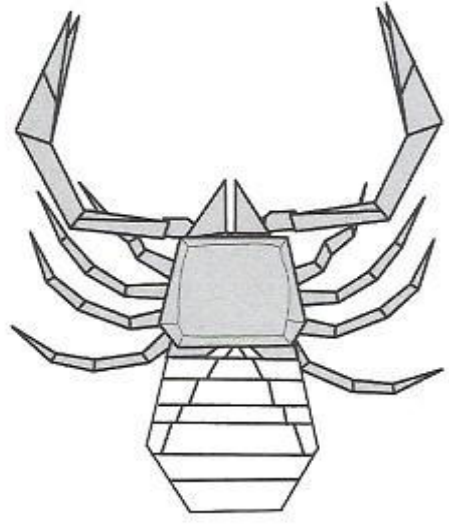

115

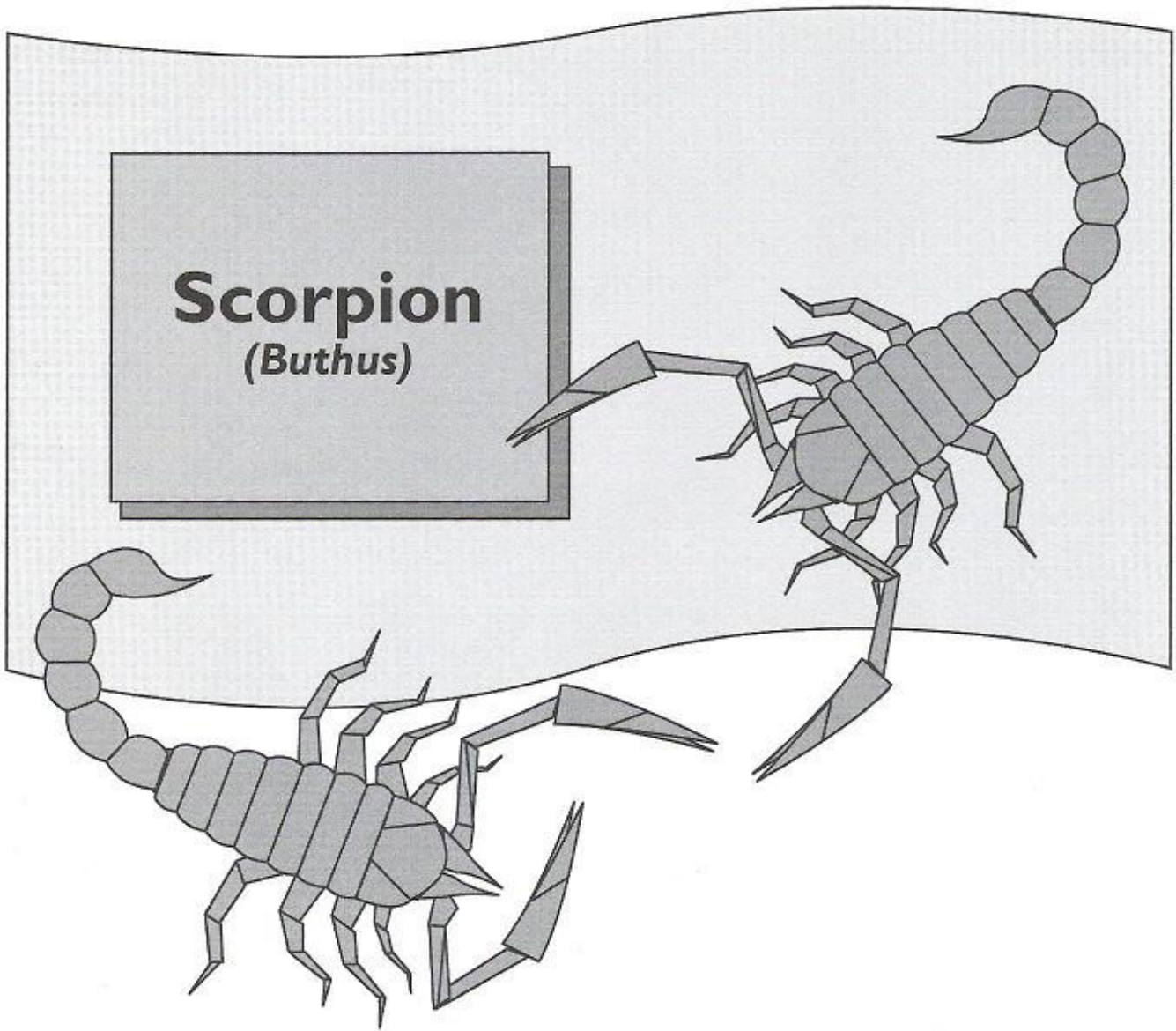

The paper should be brown. Fine paper is recommended, less than 30 grams, double silk, or "sandwich," 9.8x9.8 inches (25x25 cm) or bigger.

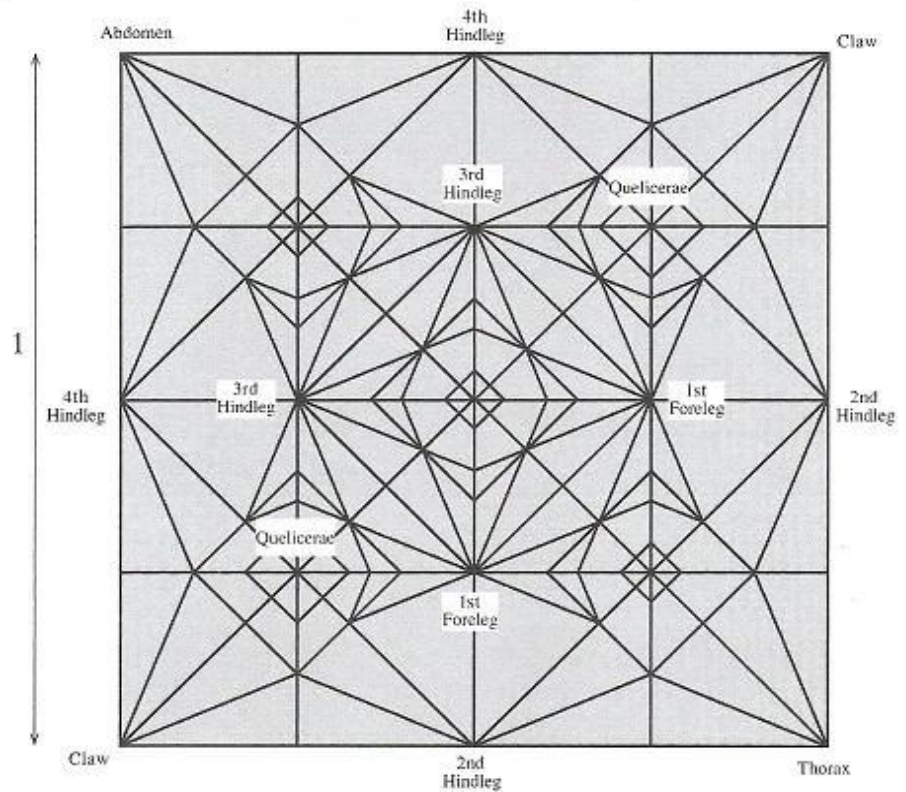
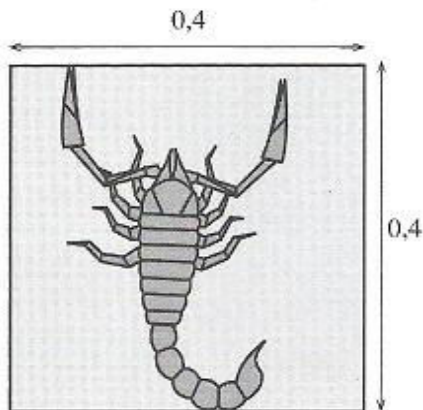

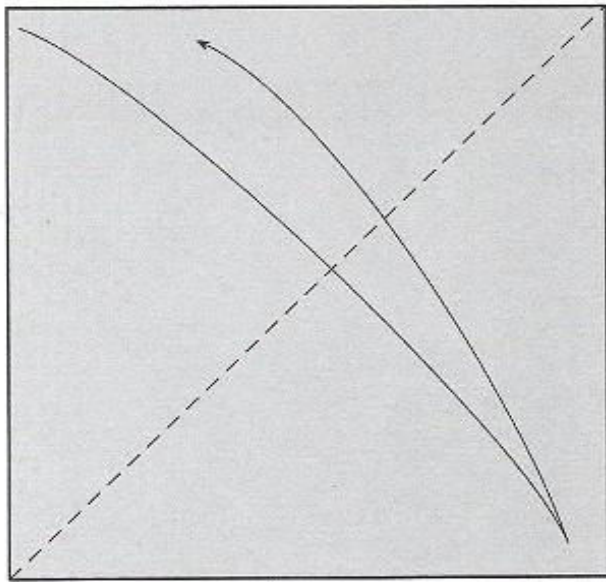

Steps 2 until 80 of Pseudoscorpion



1

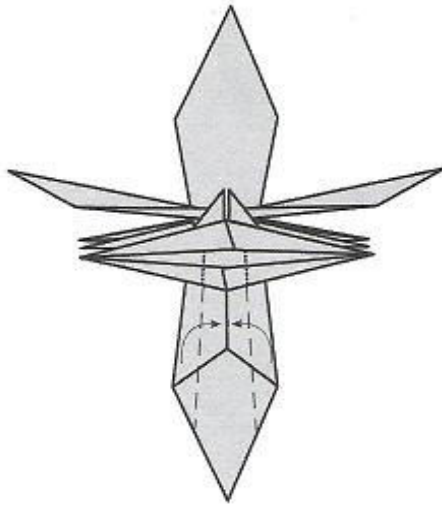

81

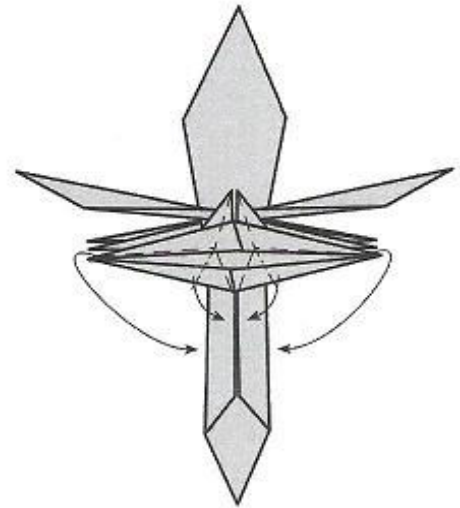

Rabbit ear for two tips

82

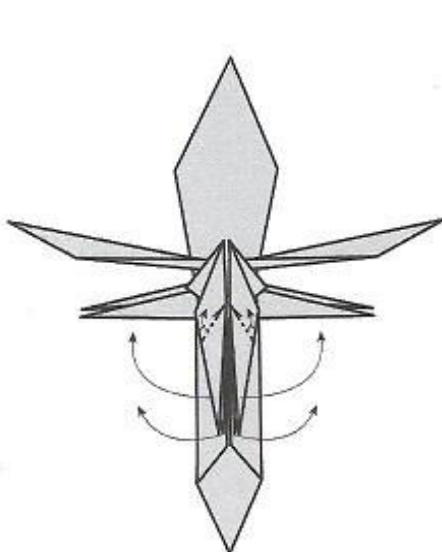

83

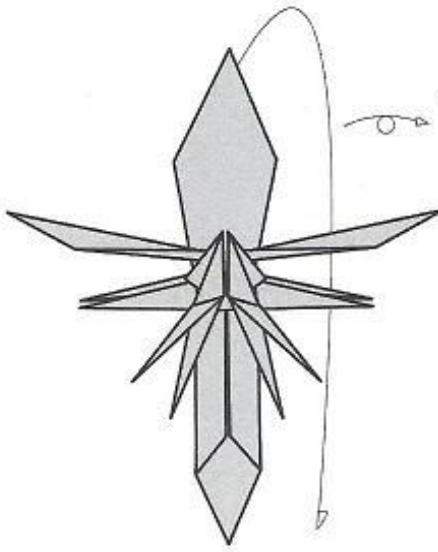

84

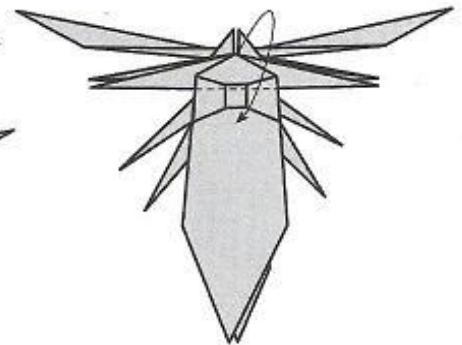

Two Layers

85

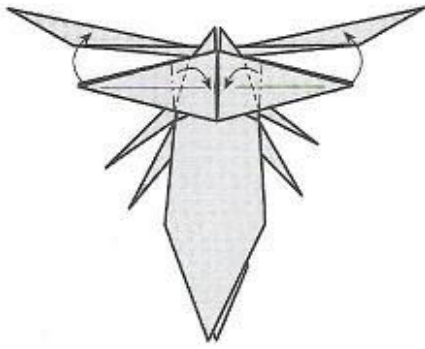

86

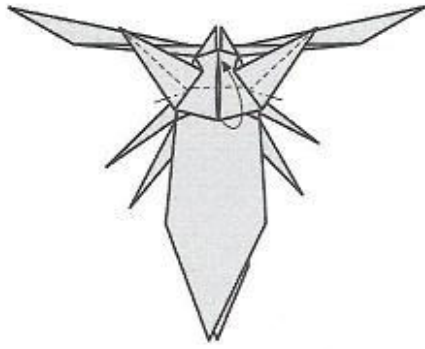

87

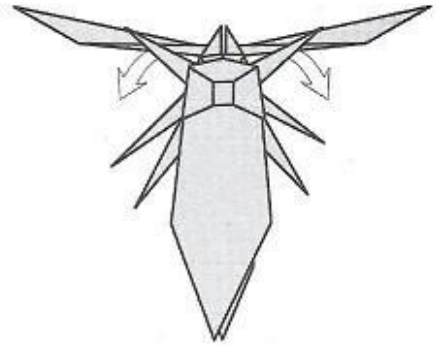

88

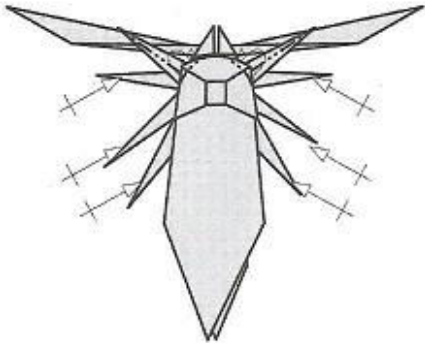

Rabbit ear in each leg

89

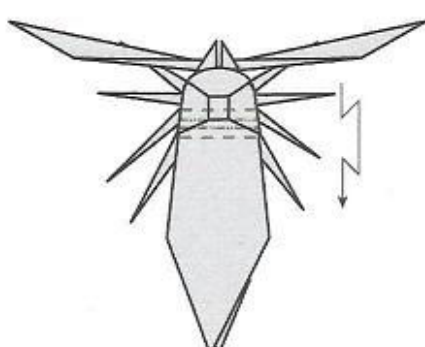

90

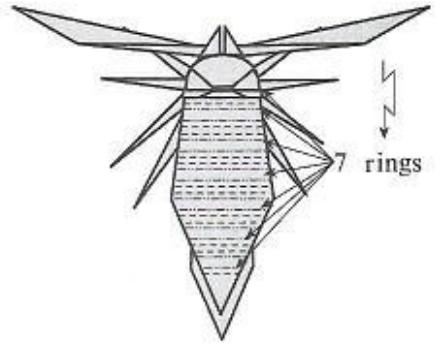

91

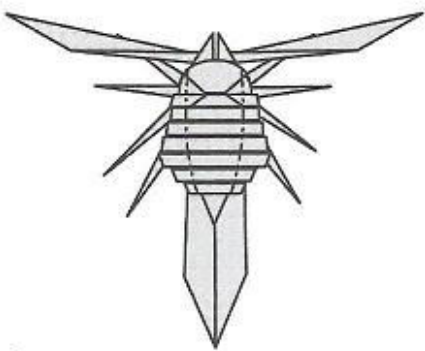

92

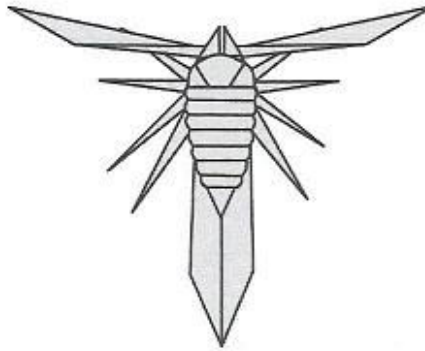

93

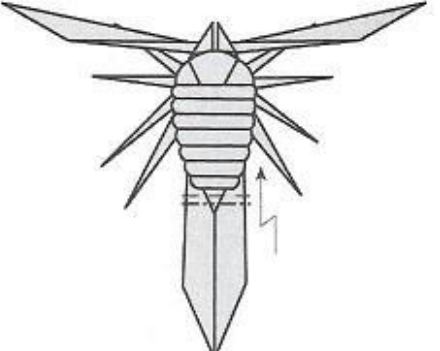

94



95

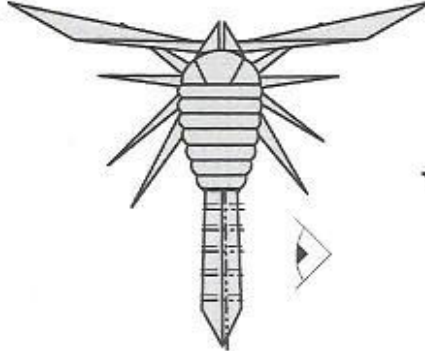

96

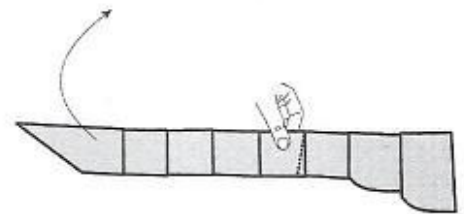

97

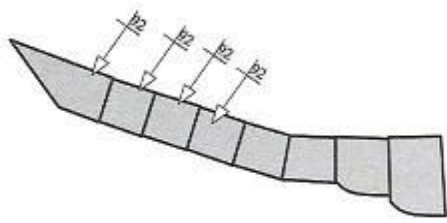

98

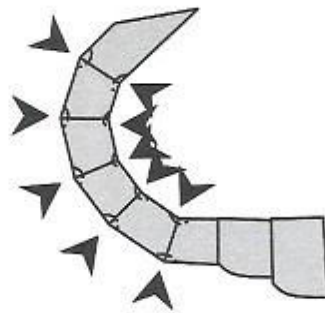

99

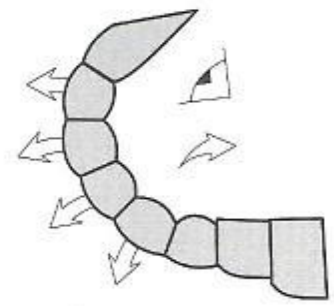

100

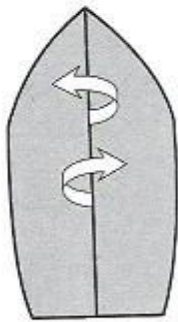

101

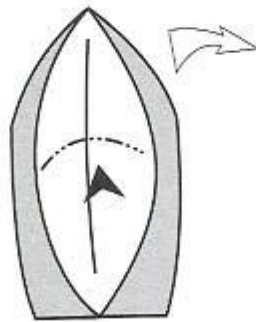

102

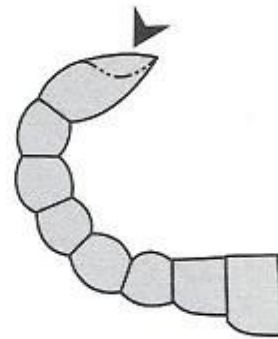

103

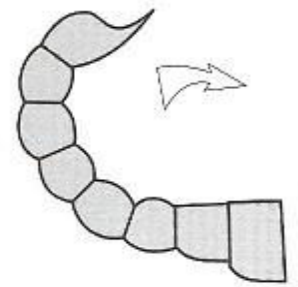

104

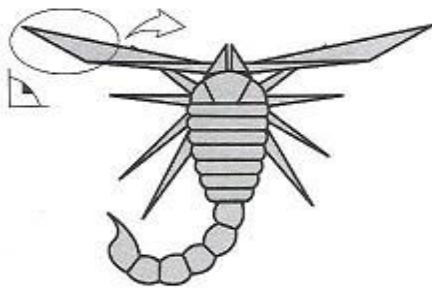

105

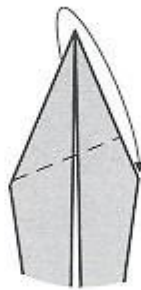

106



107

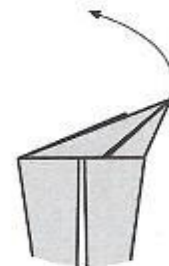

108

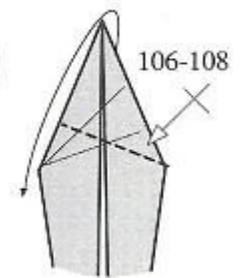

109



110



111

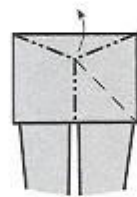

112



113



114



115



116



117

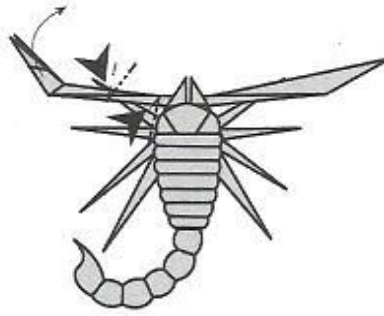

118

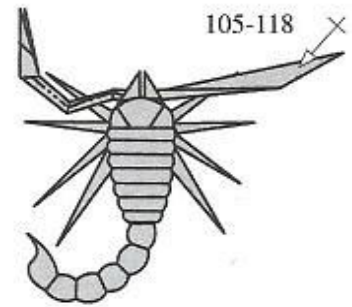

119

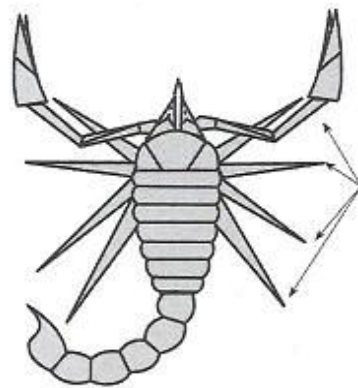

Make four segments in the legs

120

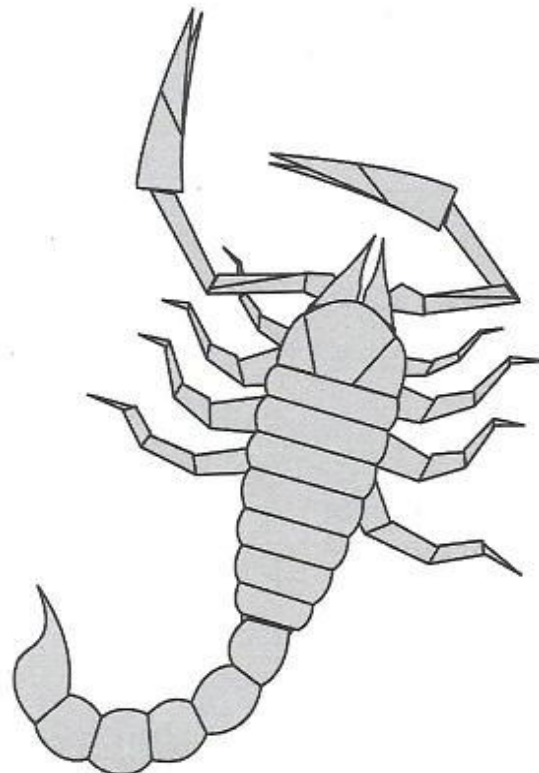

121

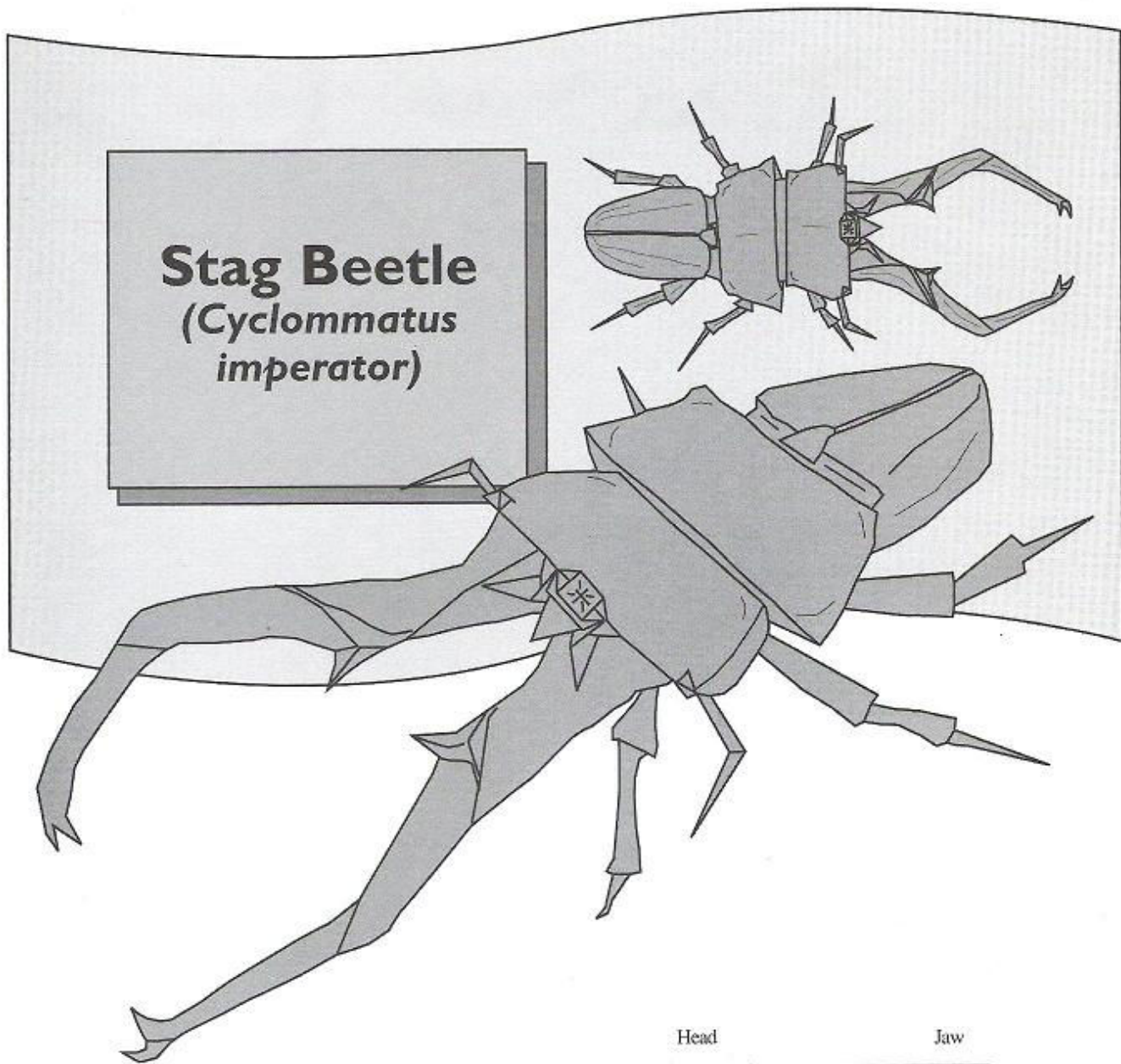

The paper should be brown or green dark. Fine paper is recommended, less than 40 grams, double silk, banana tree, lokta, metallic or "sandwich," 13.75x13.75 inches (35x35 cm) or bigger.

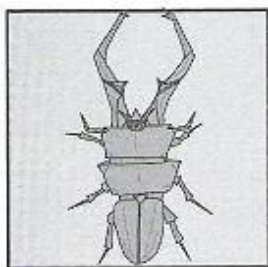

2/5

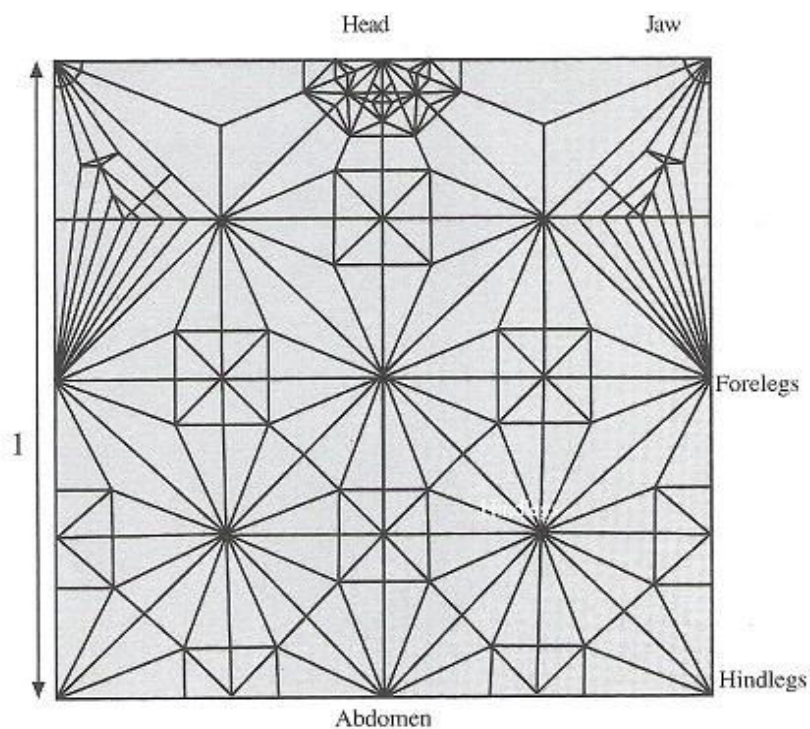

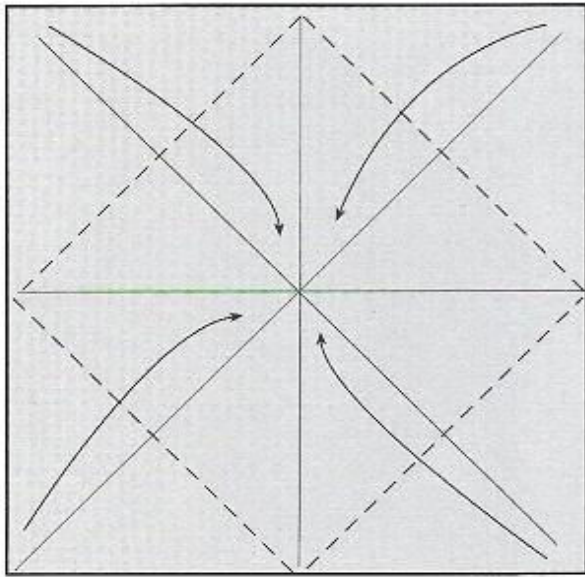

1

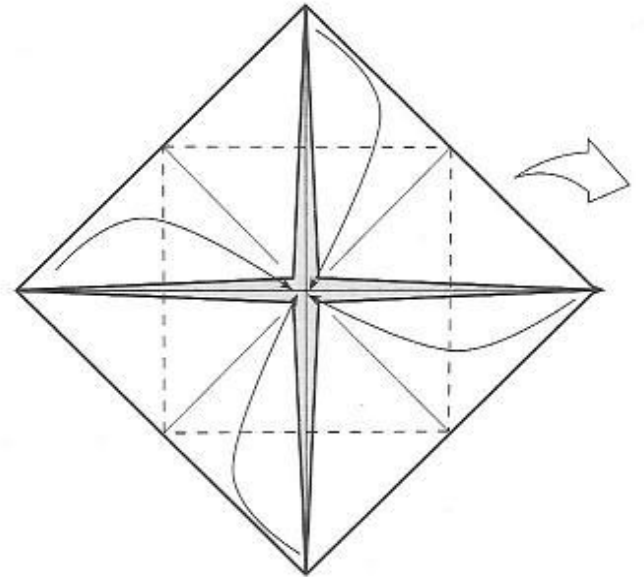

2

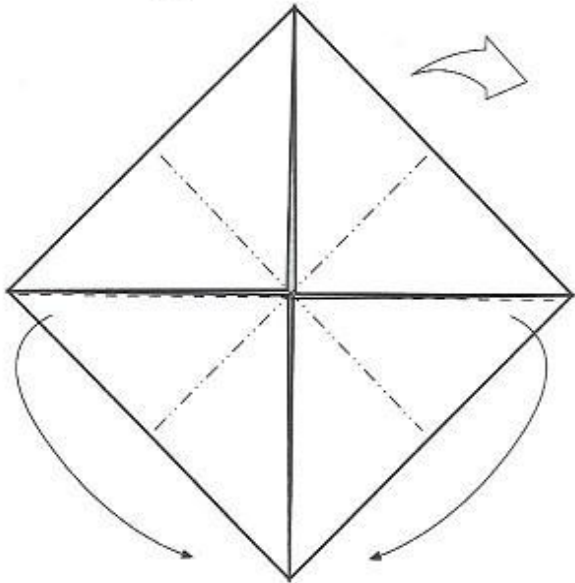

3

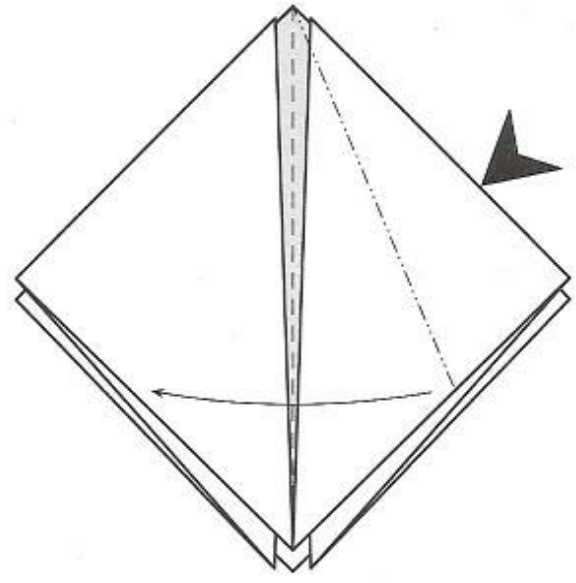

4

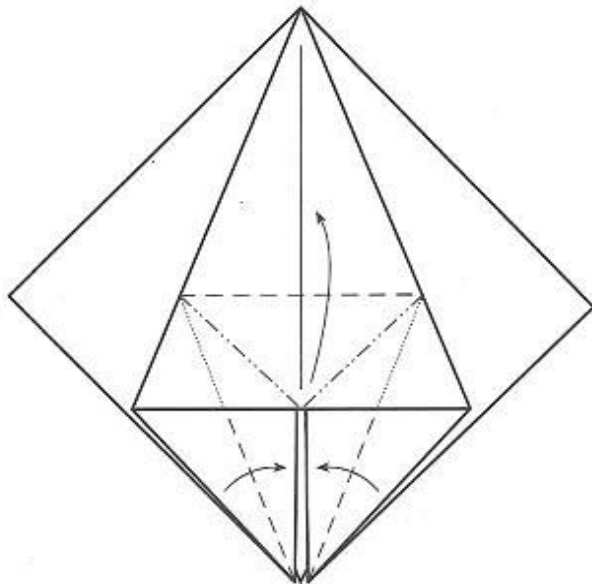

5

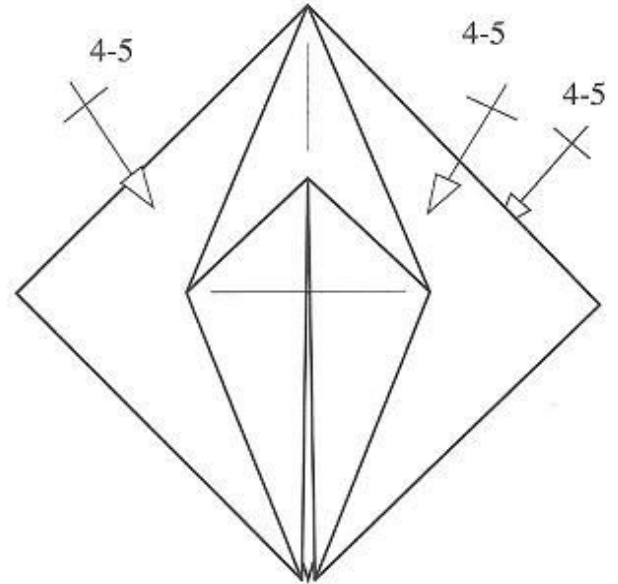

6

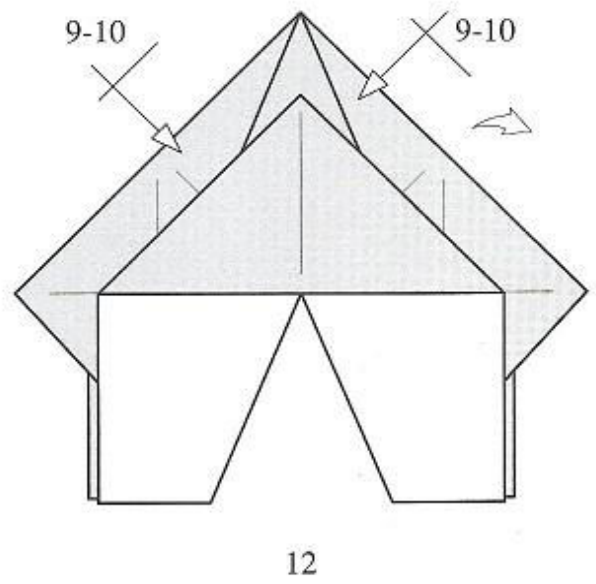
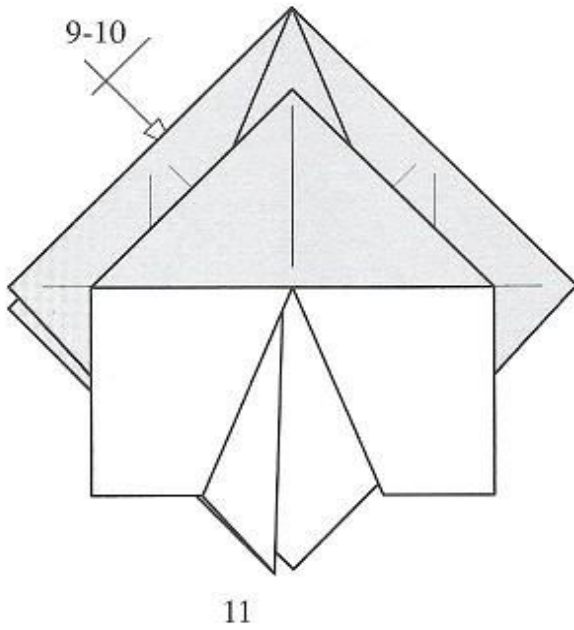
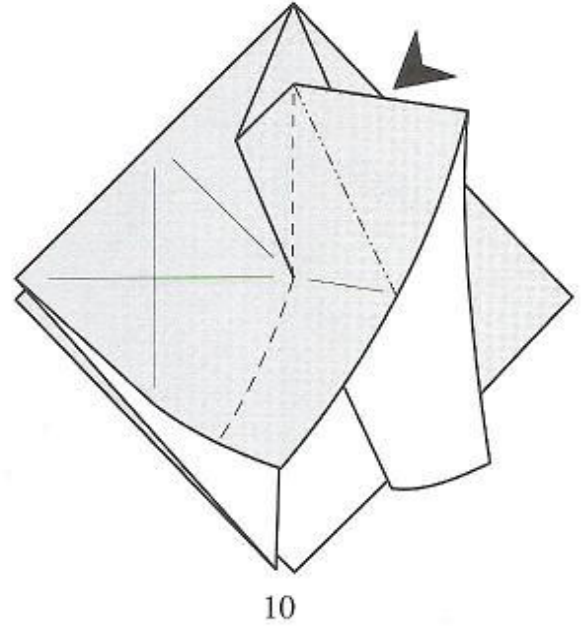
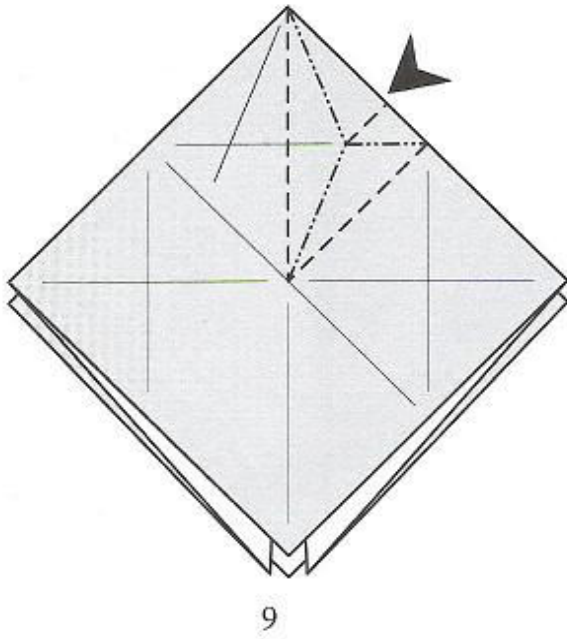
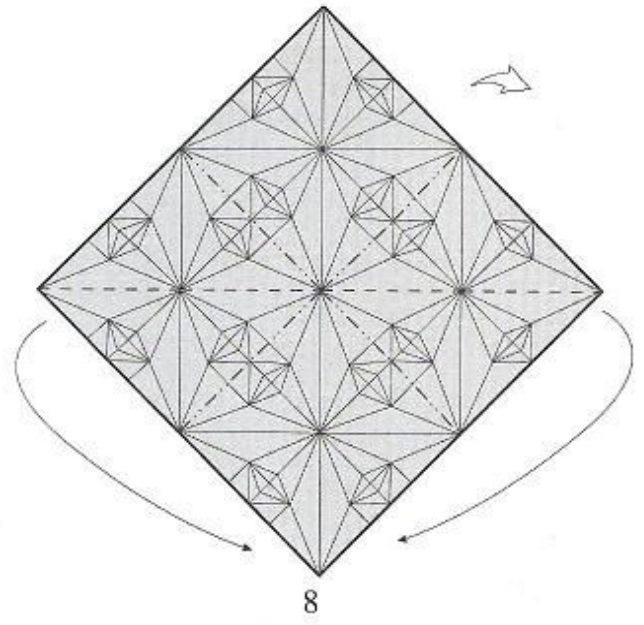
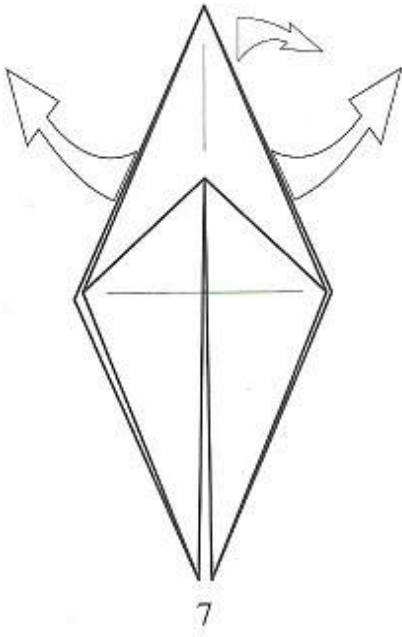

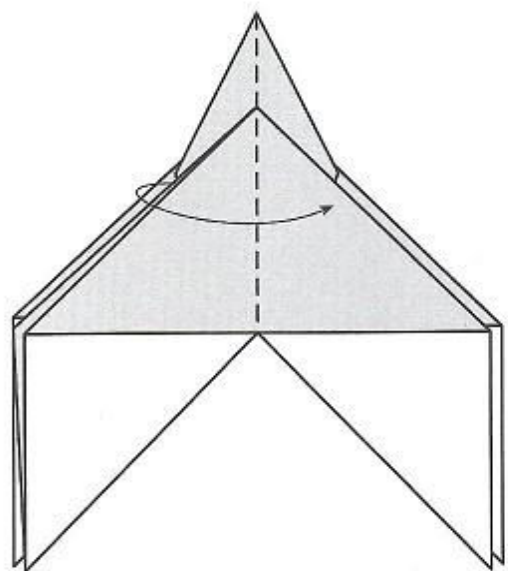

13

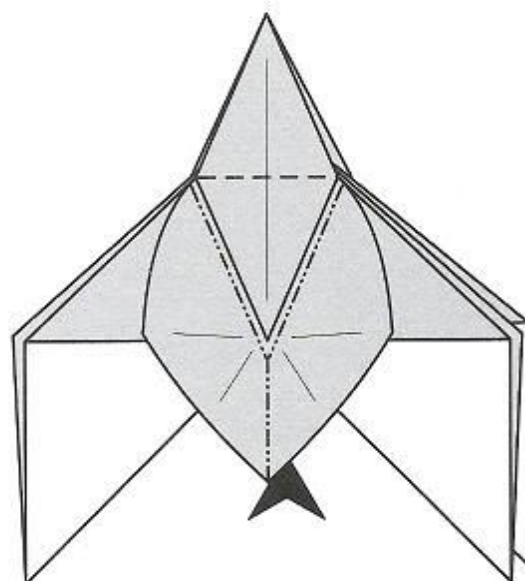

14

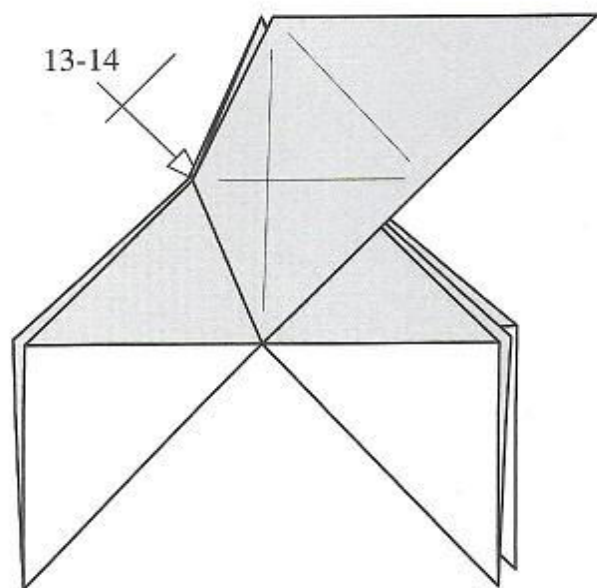

15

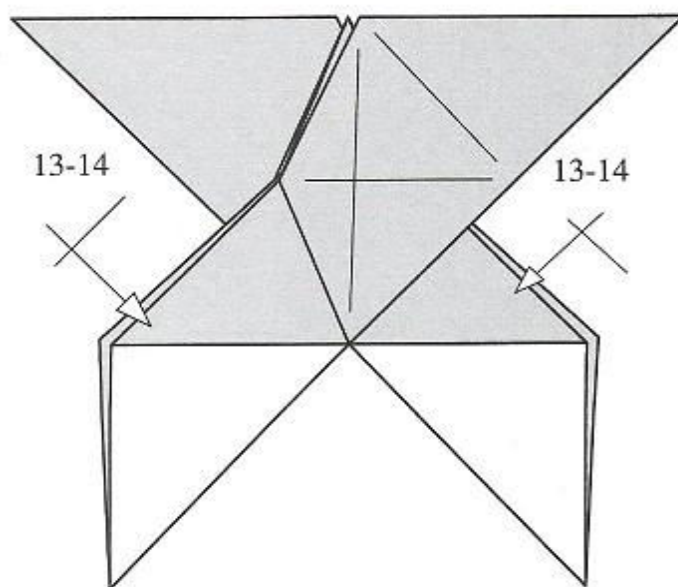

16

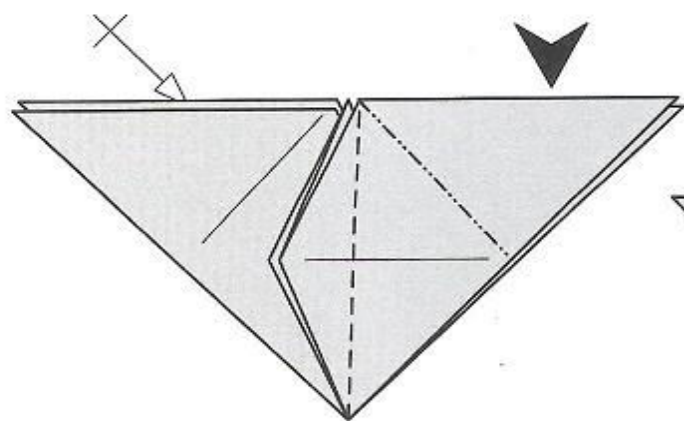

17

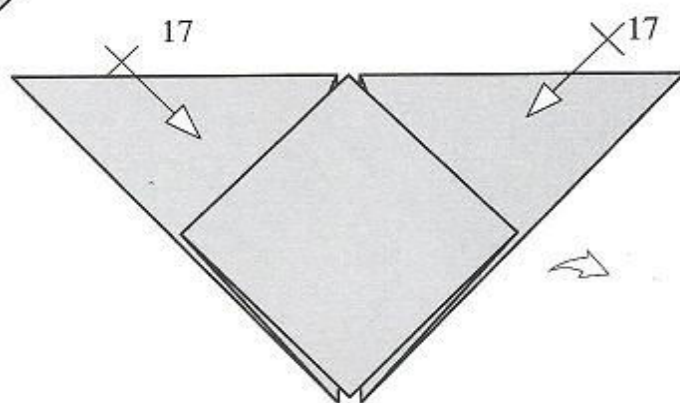

18

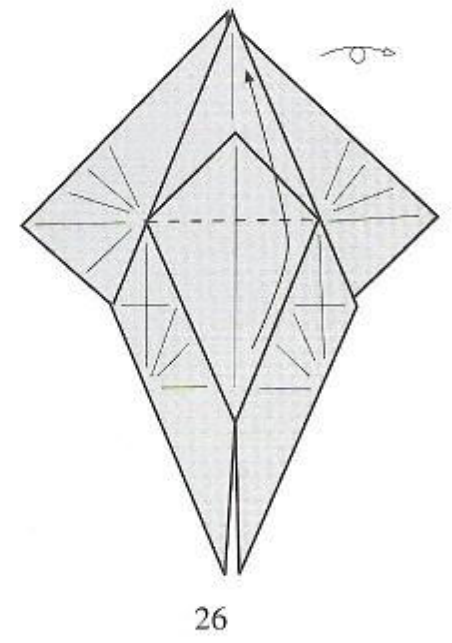
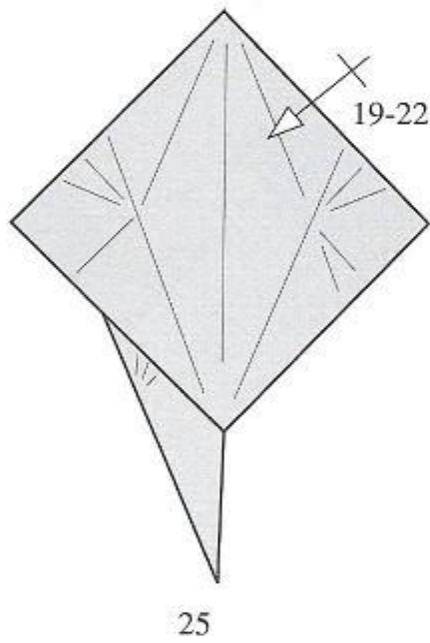
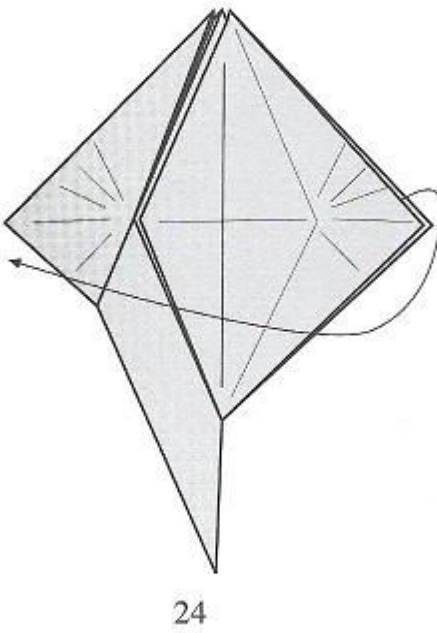
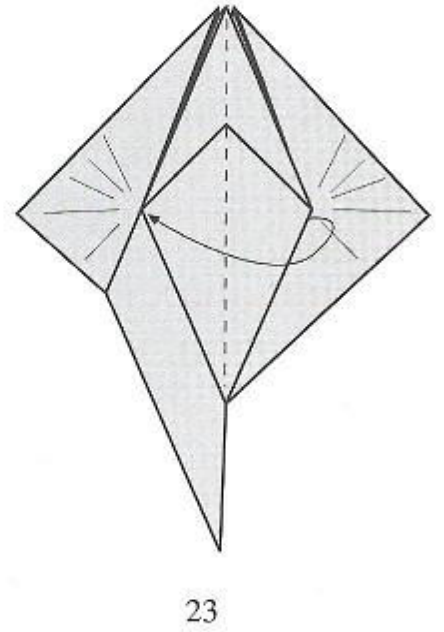
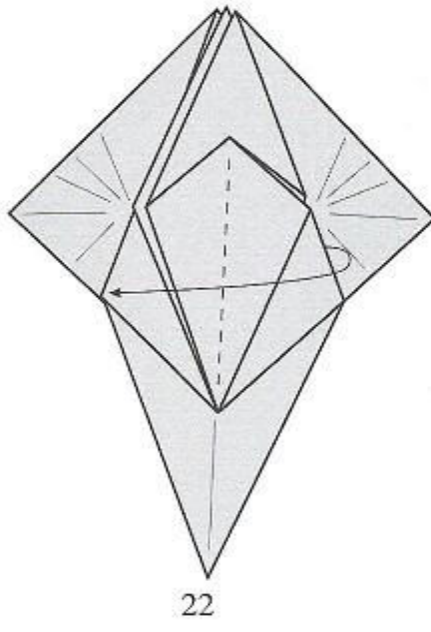
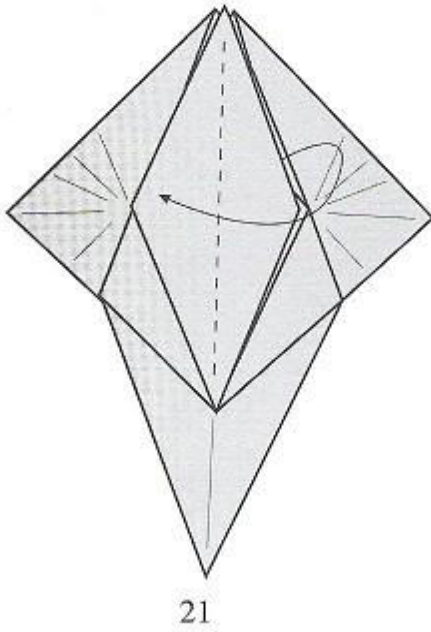
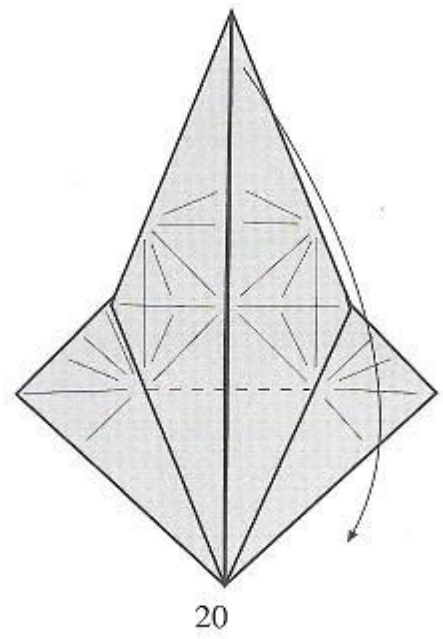
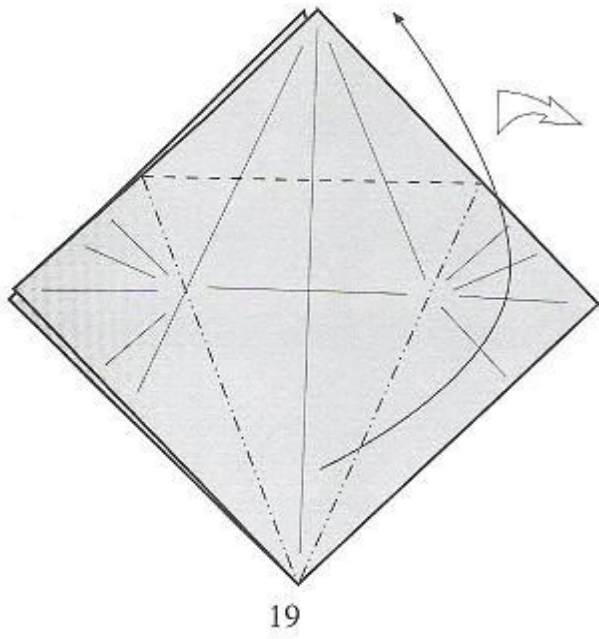

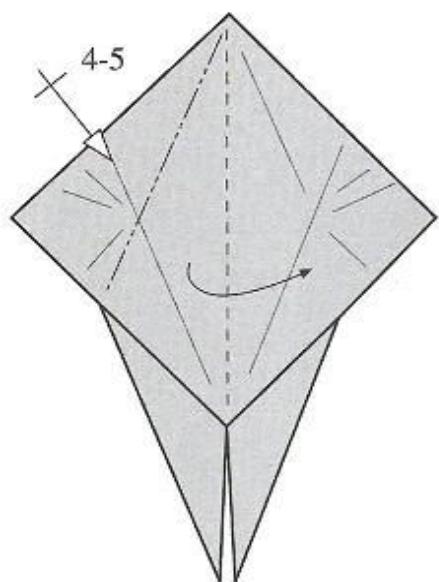

27

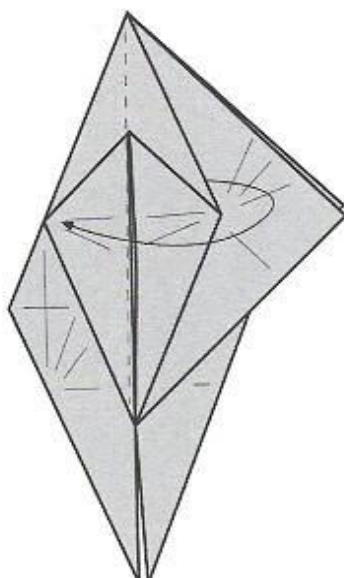

28

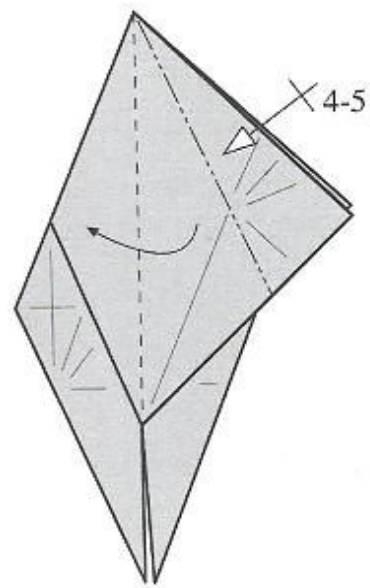

29

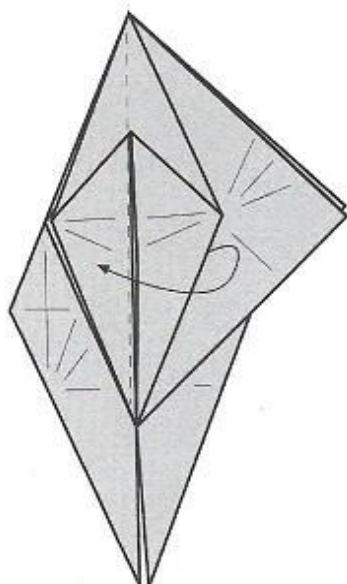

30

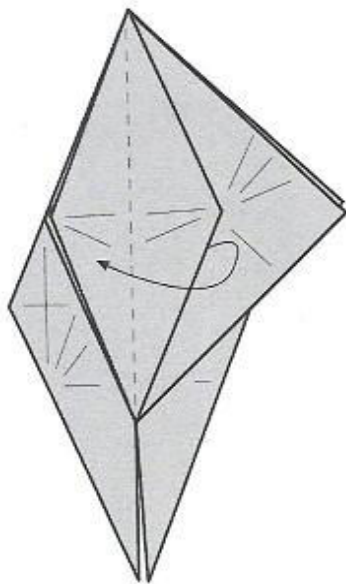

31

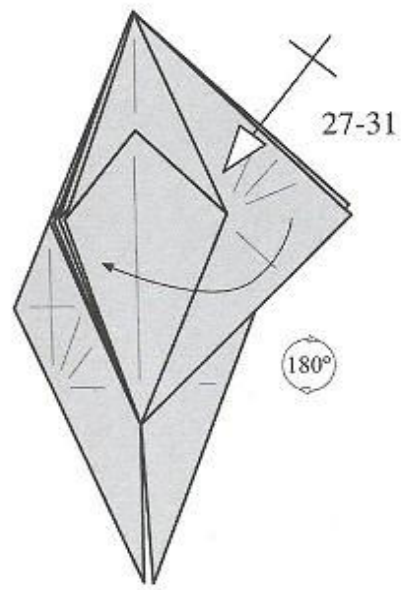

32

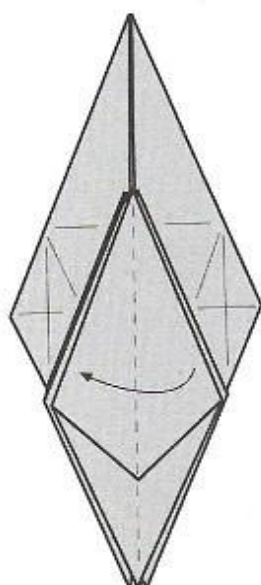

33

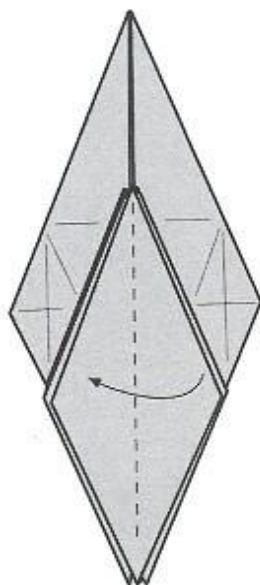

34

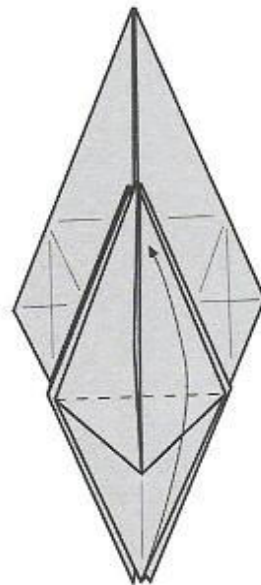

35

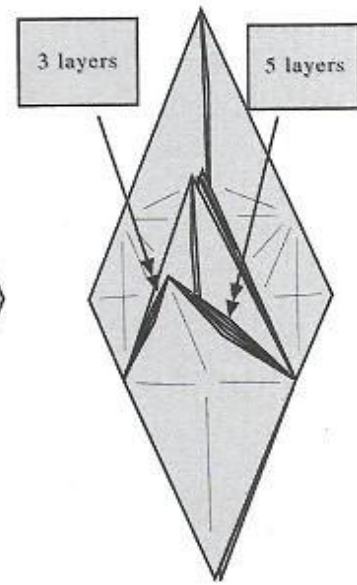

36 - 3D

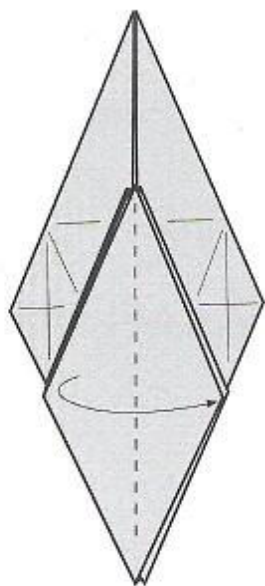

37

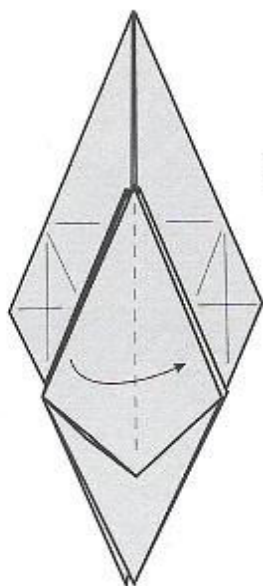

38

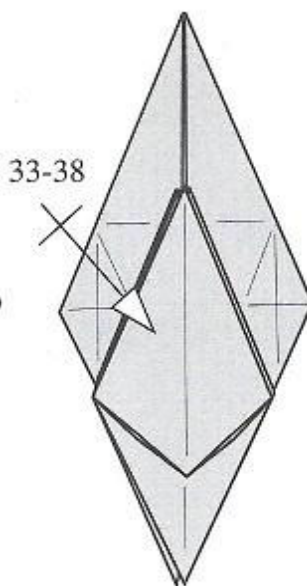

39

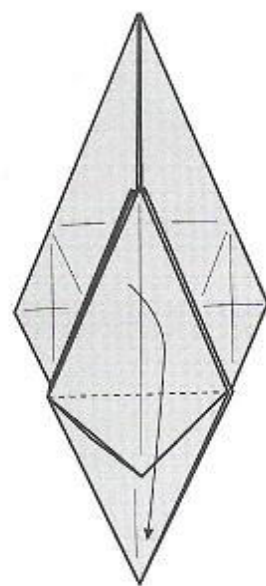

40

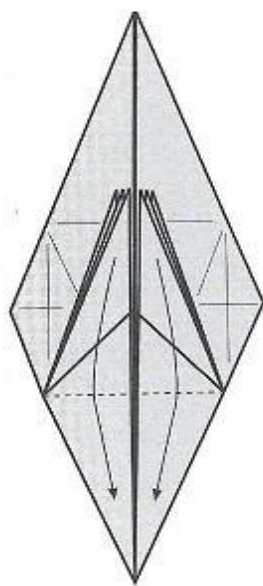

41

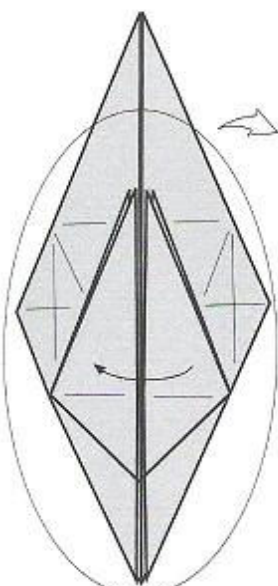

42

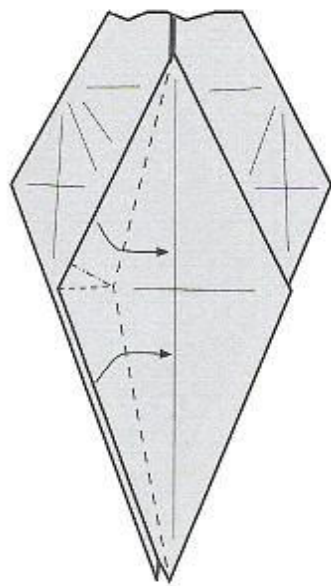

43

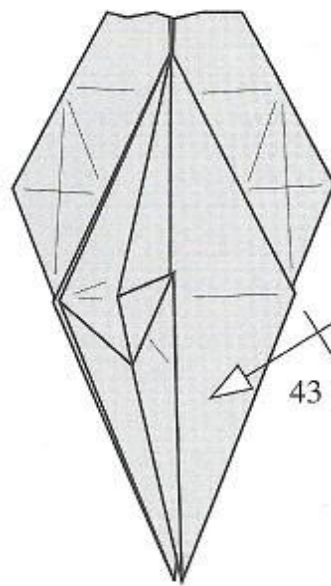

44

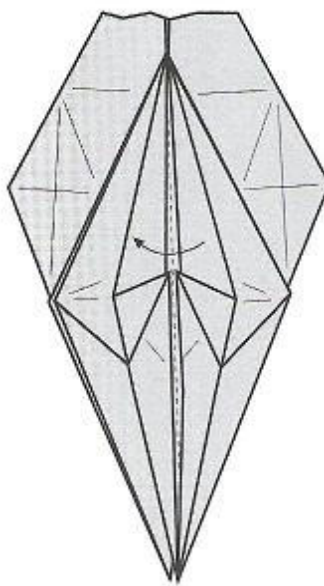

45

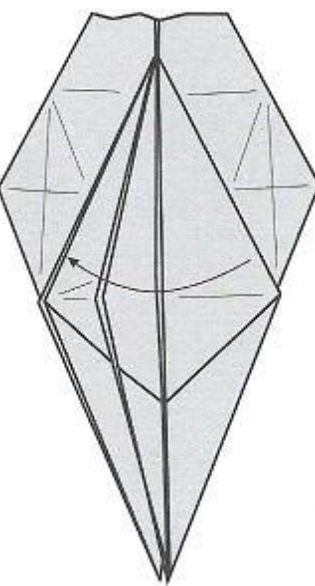

46

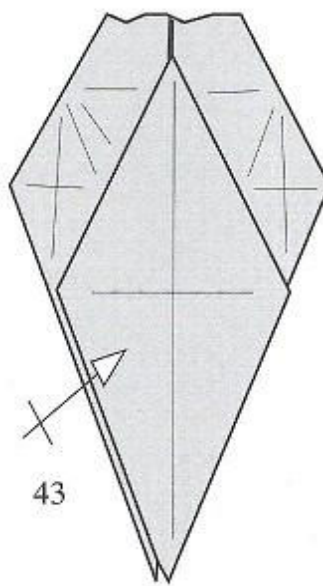

43

47

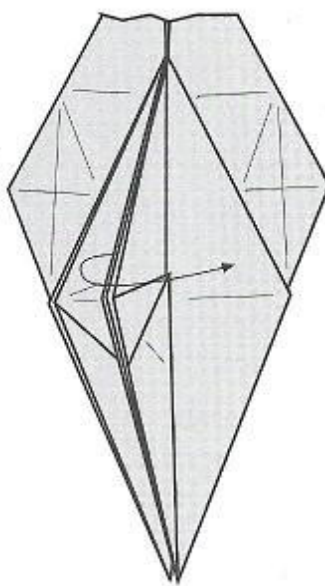

48

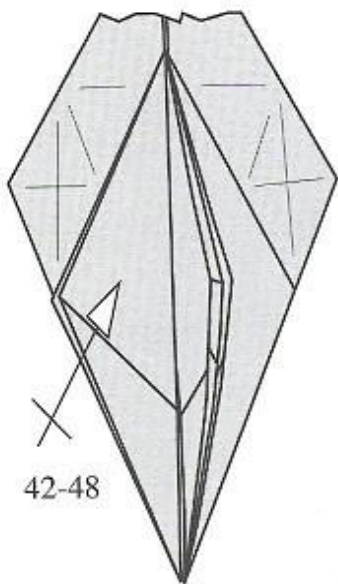

49

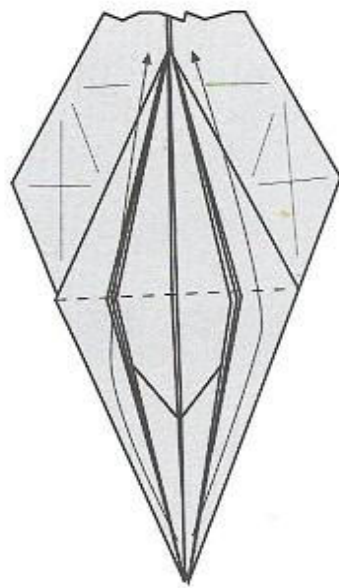

50

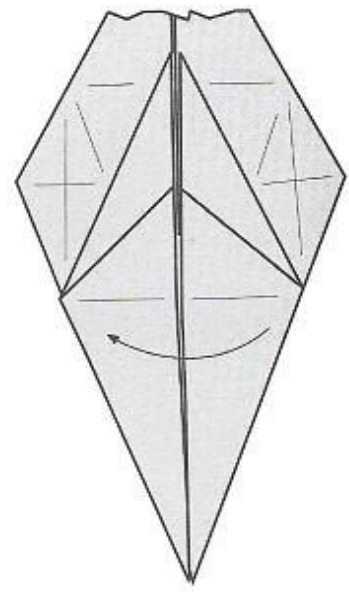

51

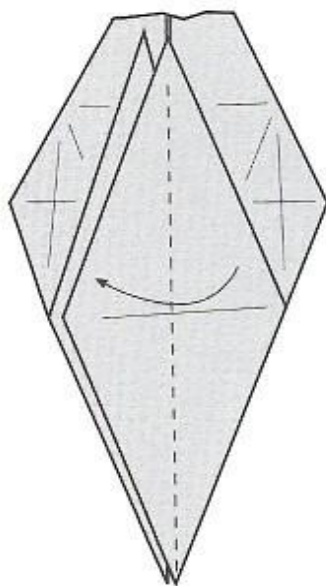

52

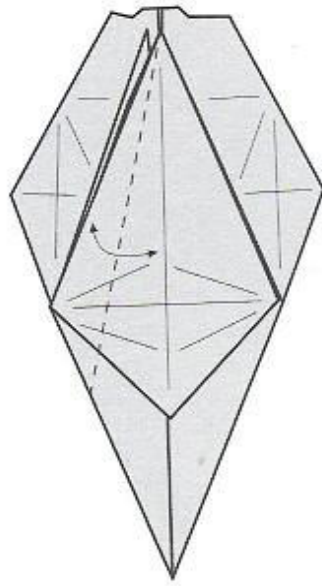

53

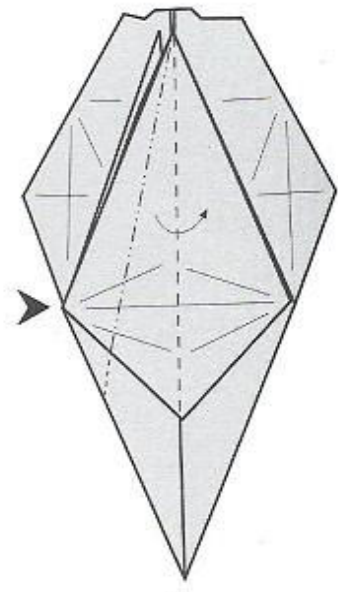

54

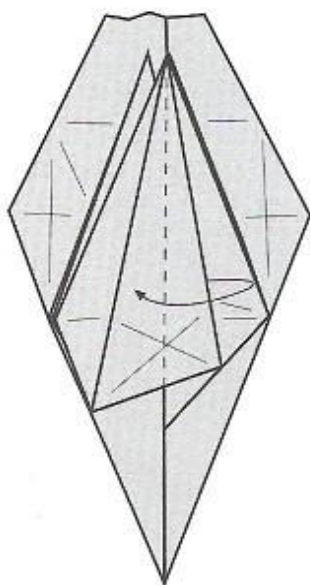

55

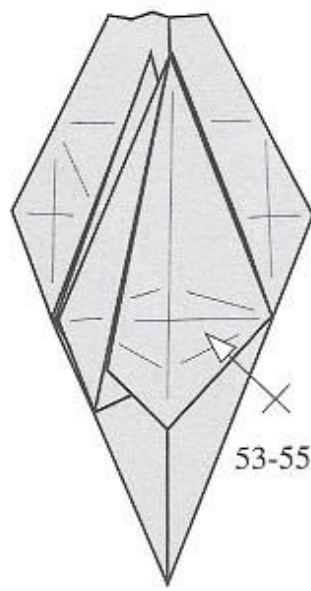

56

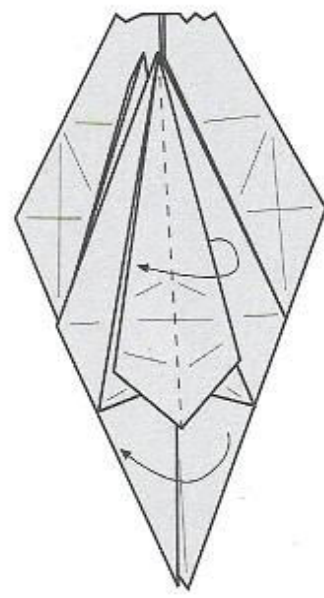

57

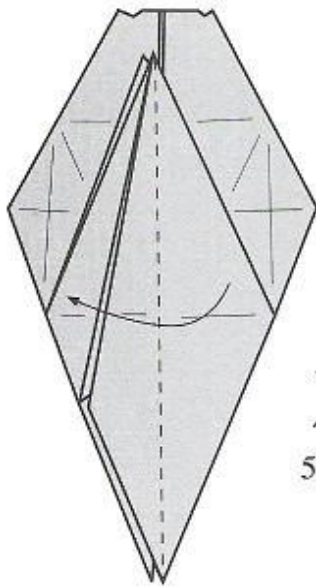

58

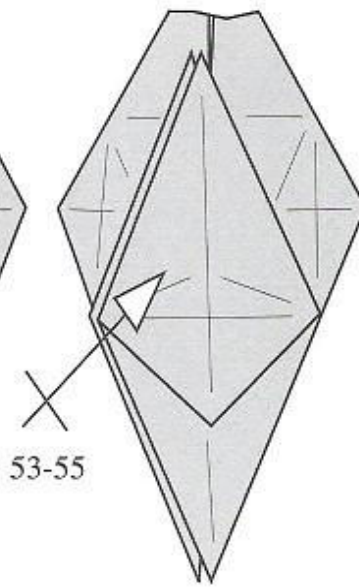

53-55

59

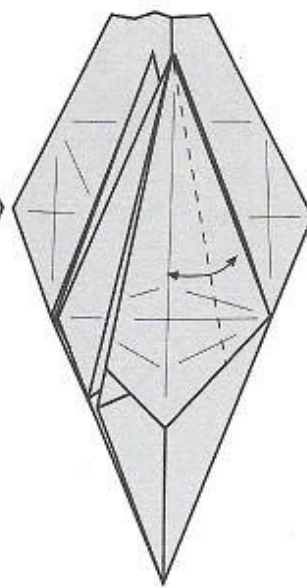

60

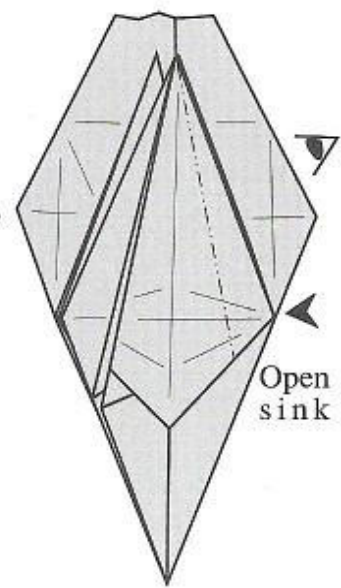

Open sink

61

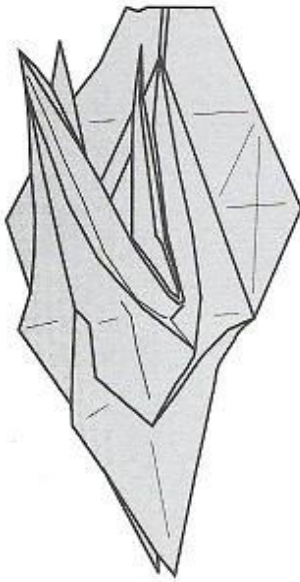

62

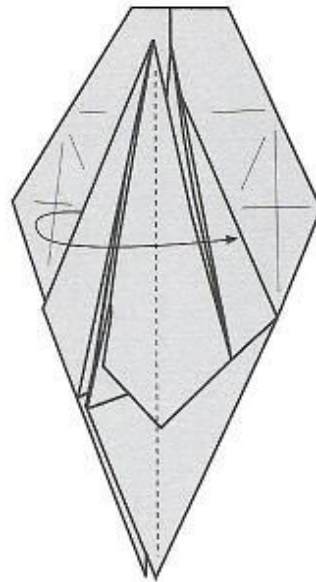

63

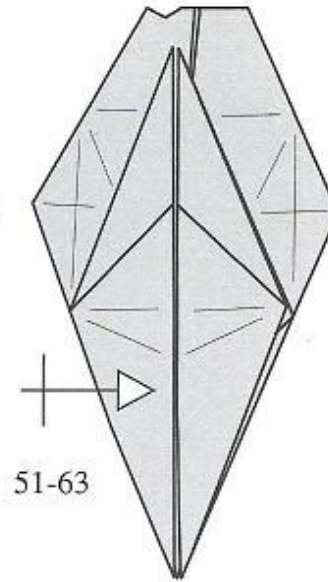

51-63

64

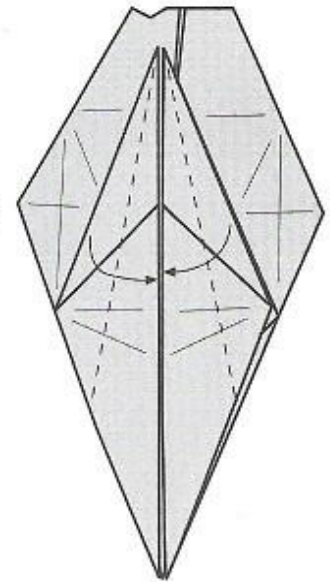

65

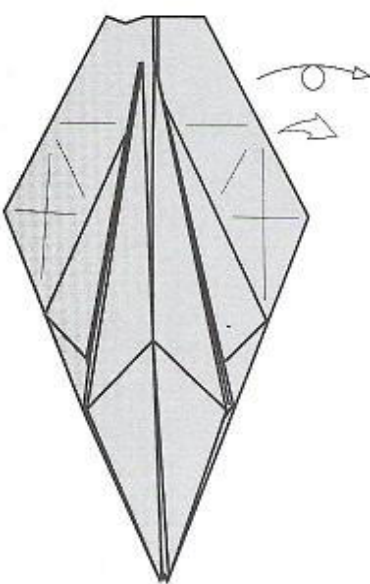

66

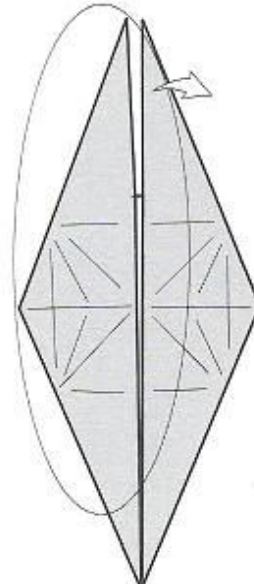

67

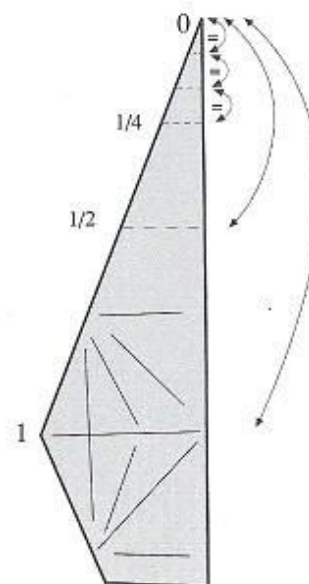

68

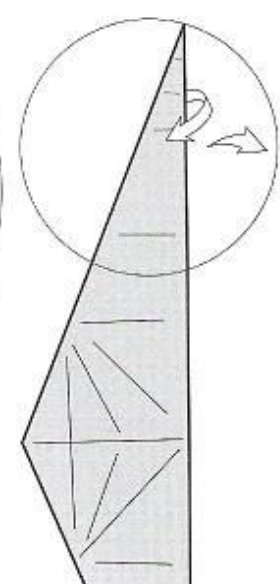

69

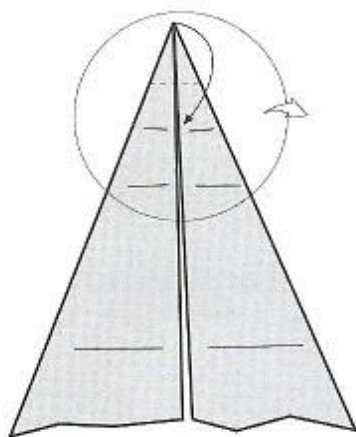

70

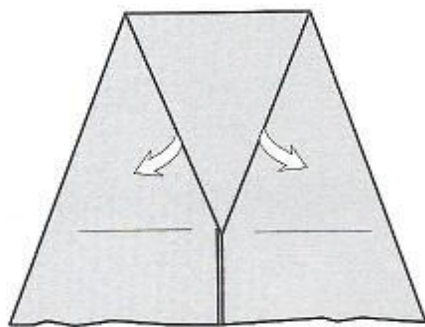

71

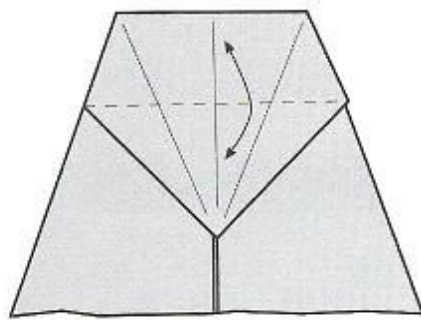

72

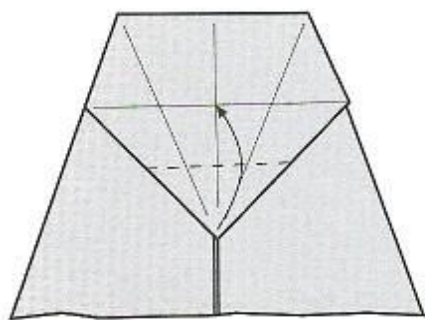

73

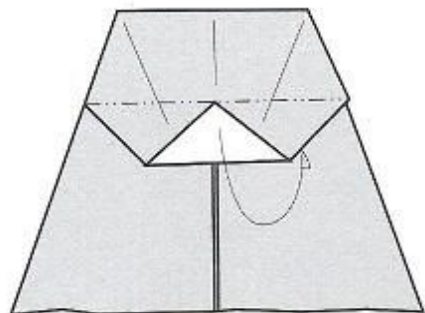

74

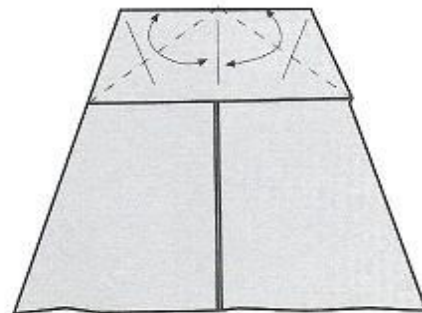

75

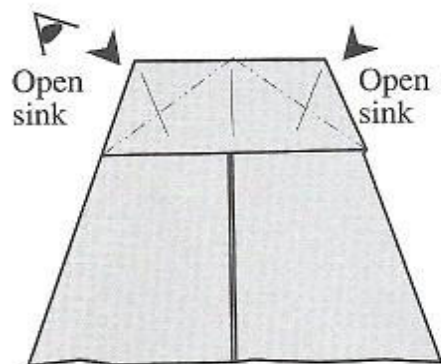

76

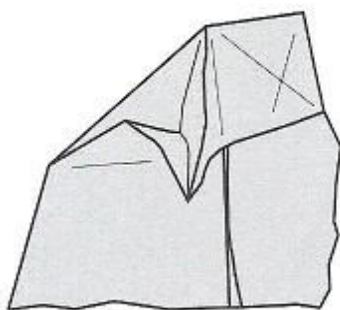

77-3D

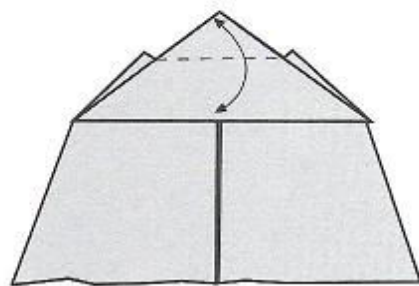

78

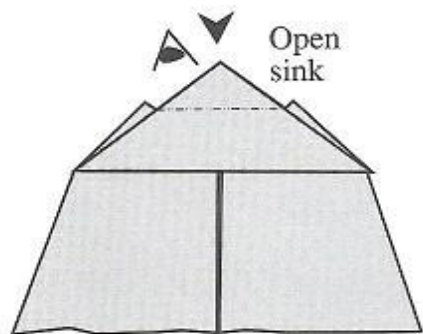

79



80-3D



81

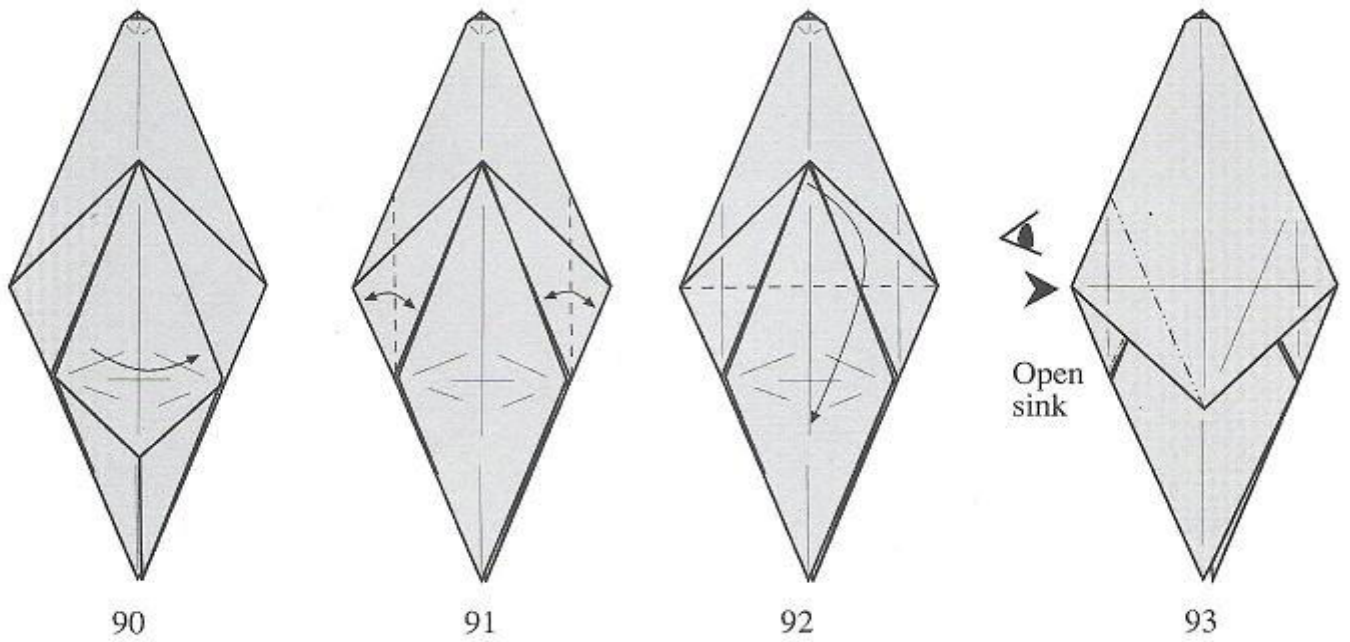
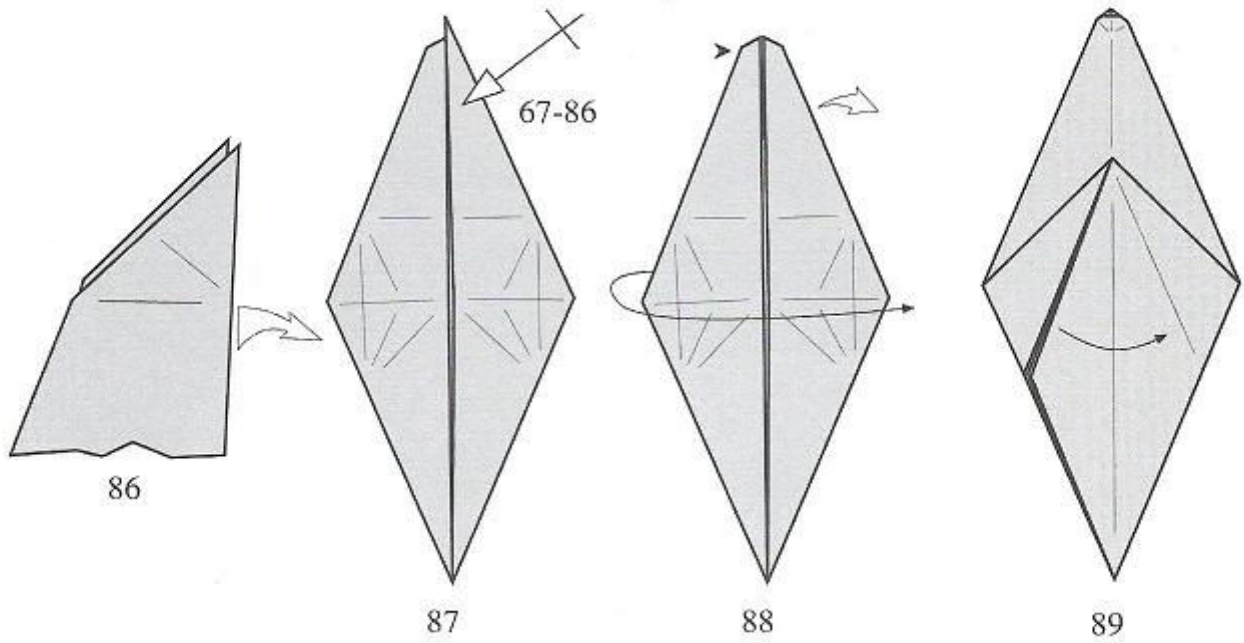
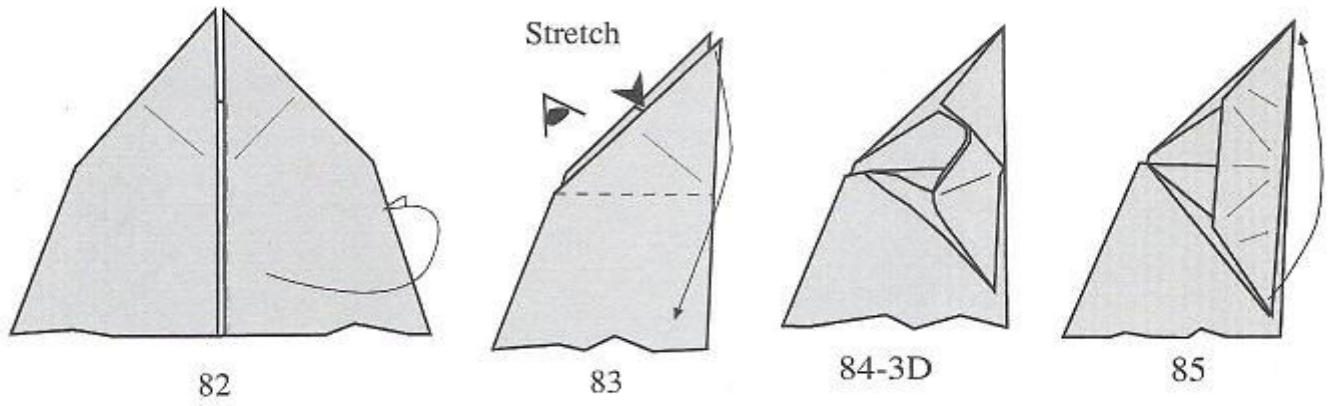



94-3D

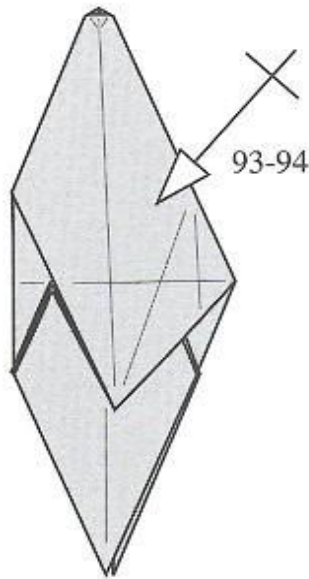

95

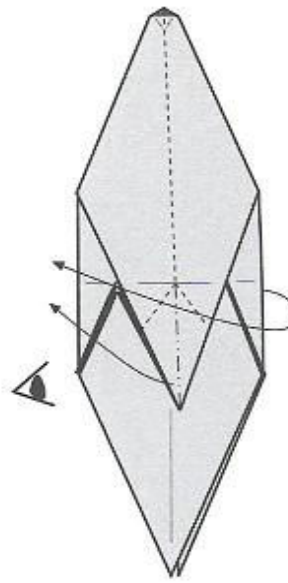

96

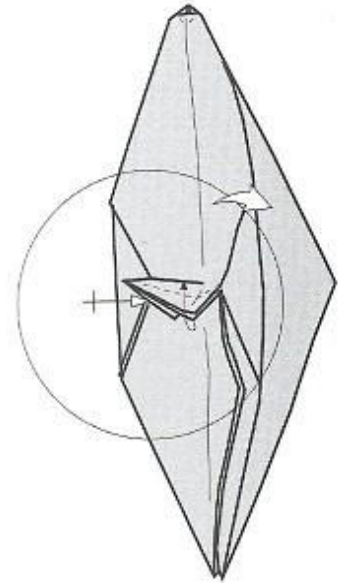

97-3D

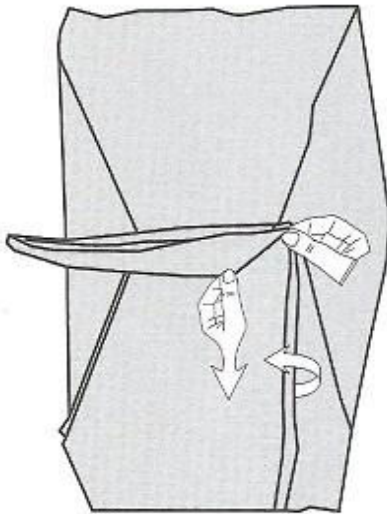

98-3D

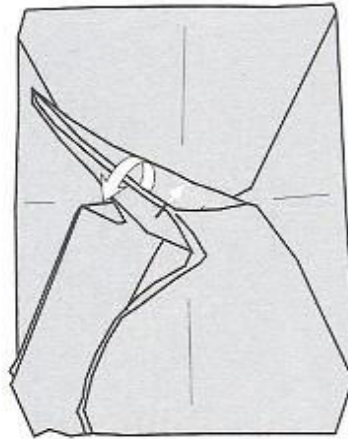

99-3D

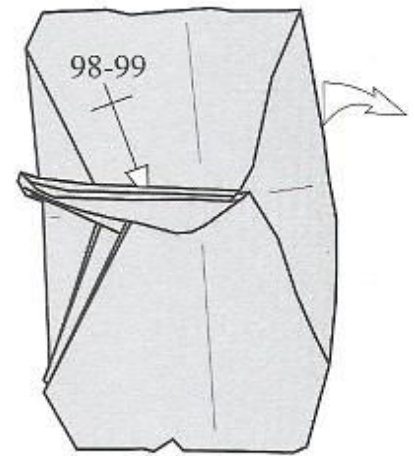

100-3D

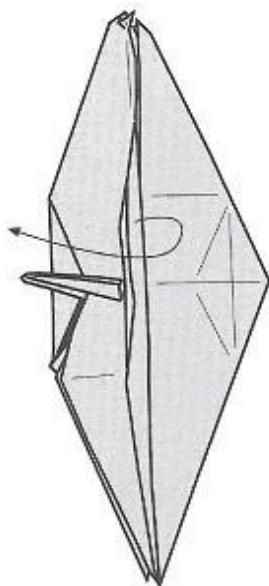

101-3D

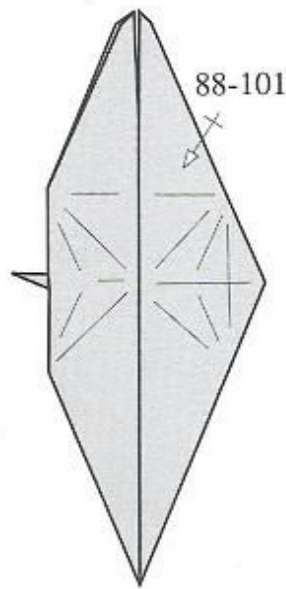

102

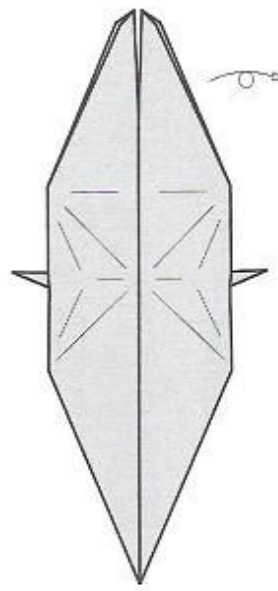

103

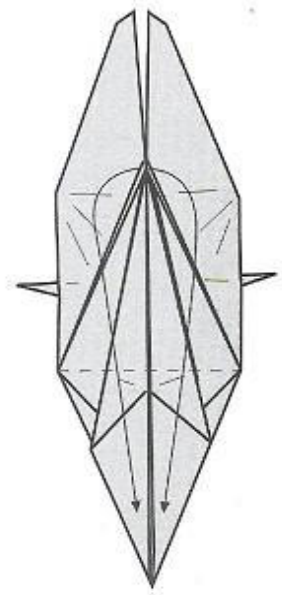

104

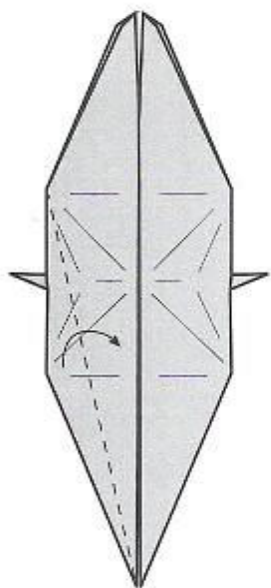

105

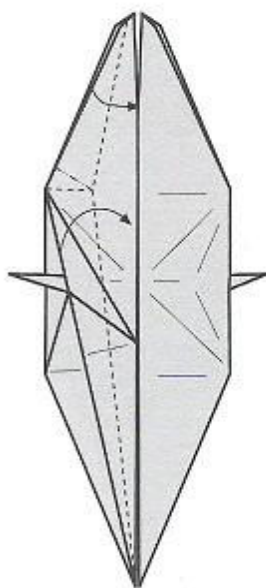

106

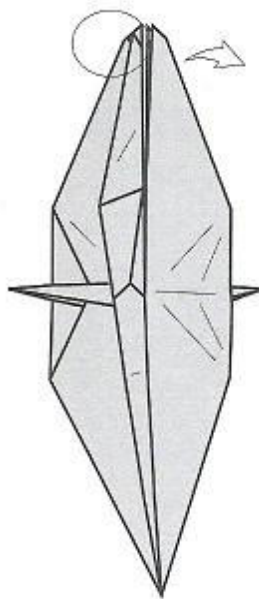

107

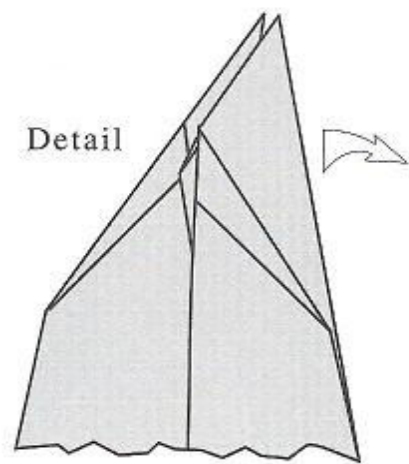

Detail

108

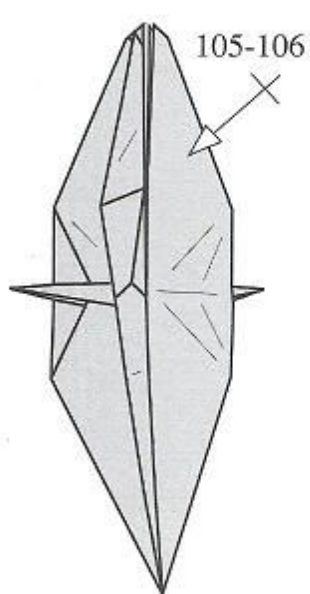

109

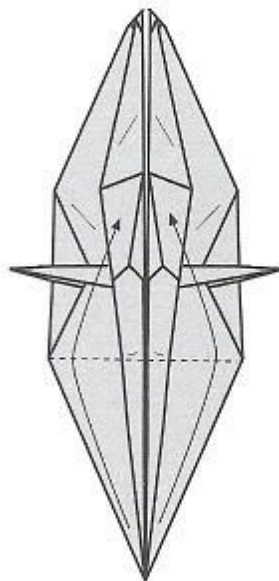

110

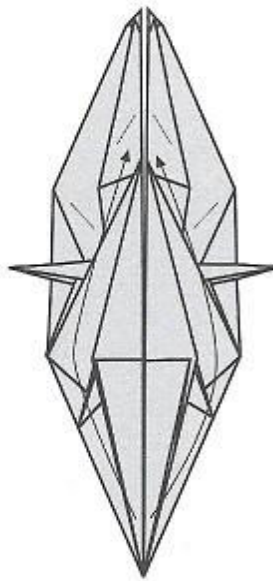

111

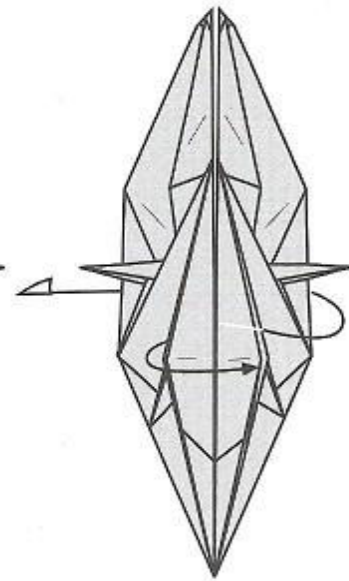

112

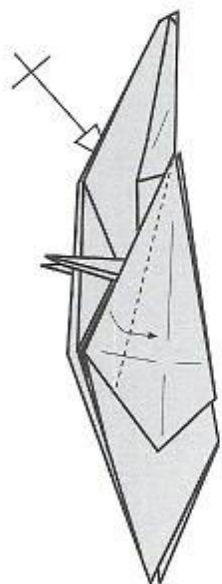

113

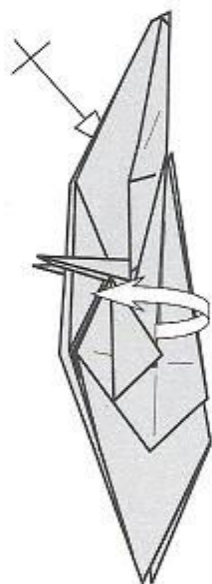

114

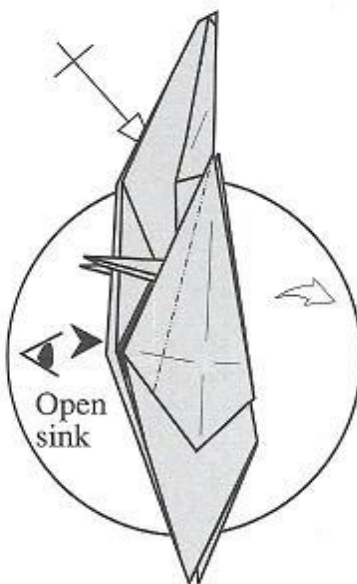

Open sink

115

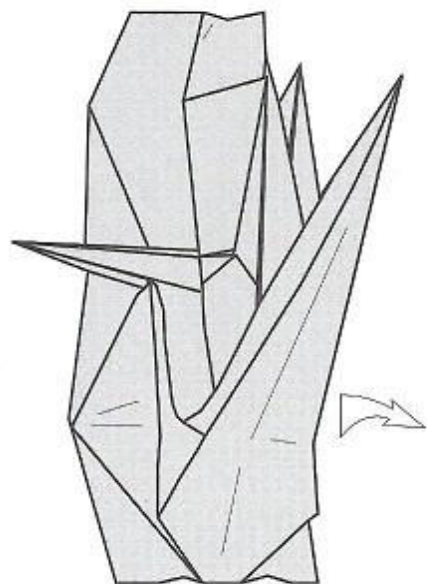

116-3D

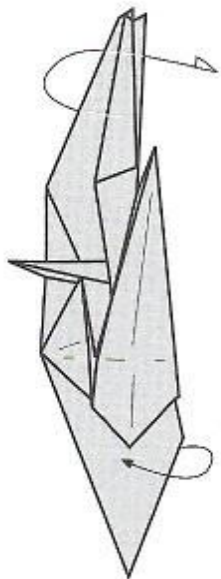

117

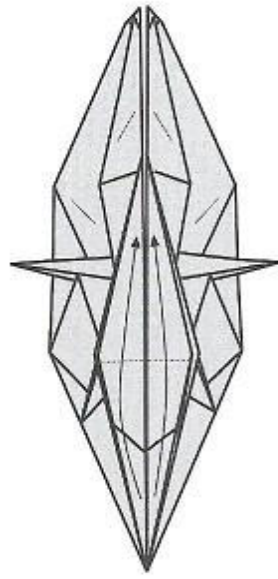

118

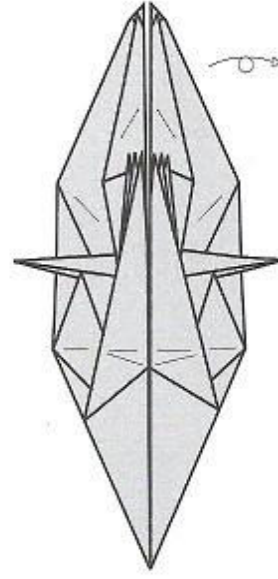

119

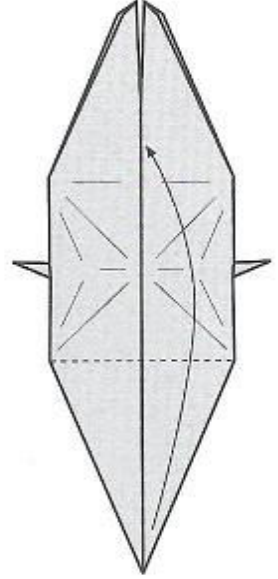

120

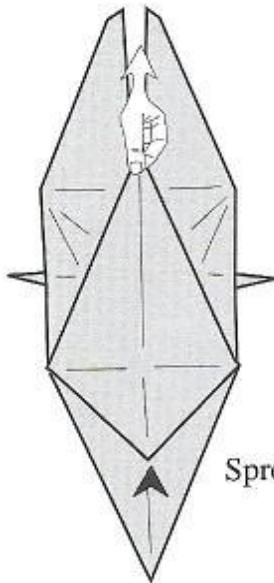

121

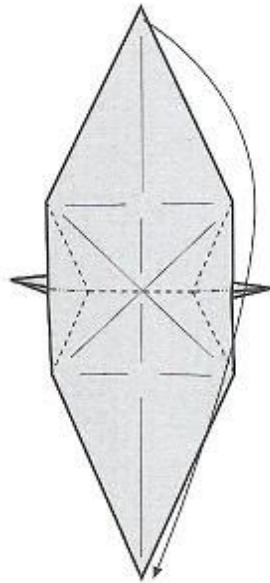

122

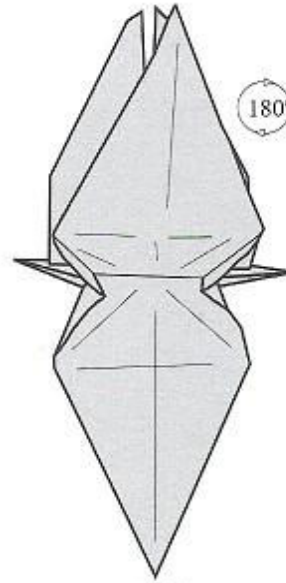

123-3D

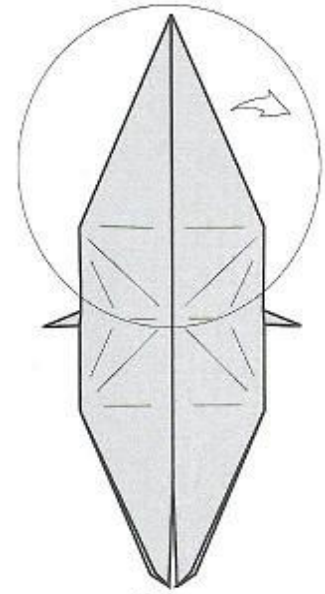

124

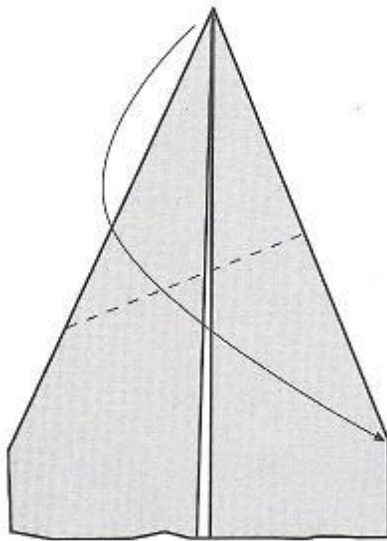

125

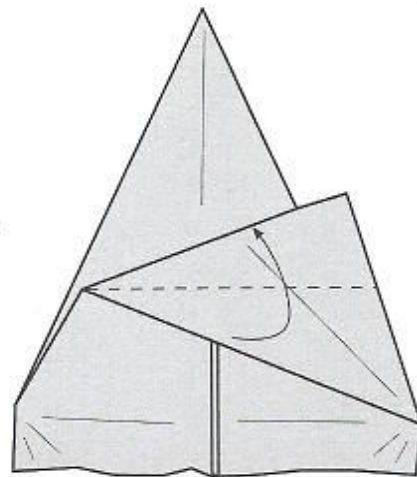

126

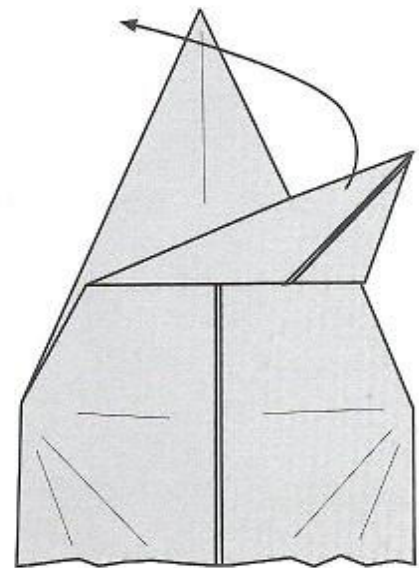

127

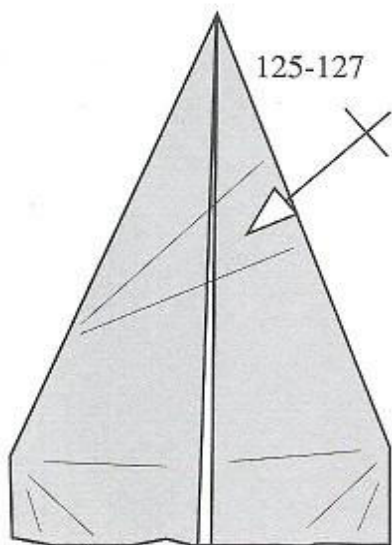

128

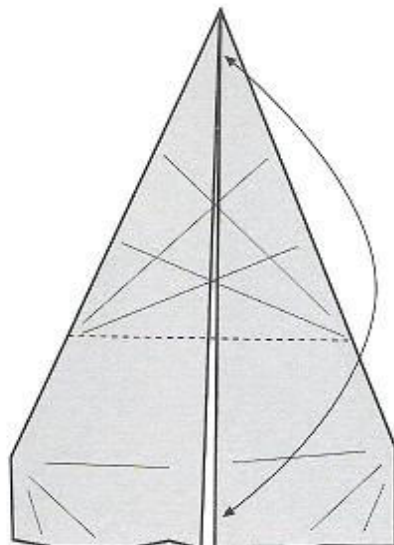

129

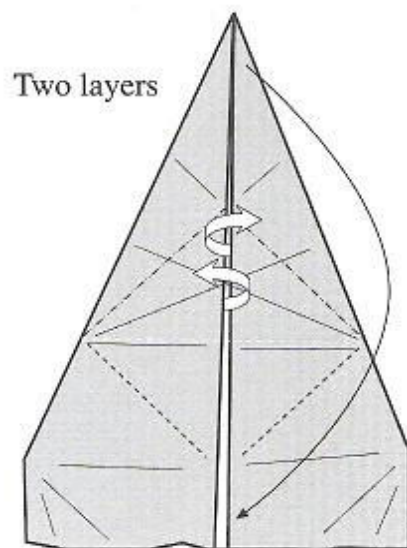

Two layers

130

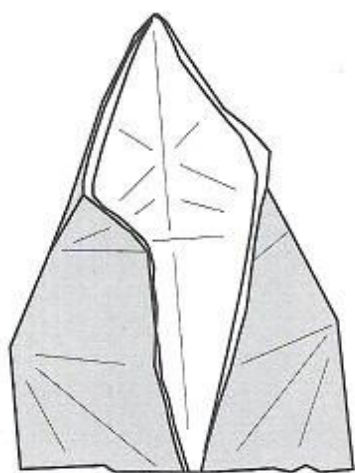

131-3D

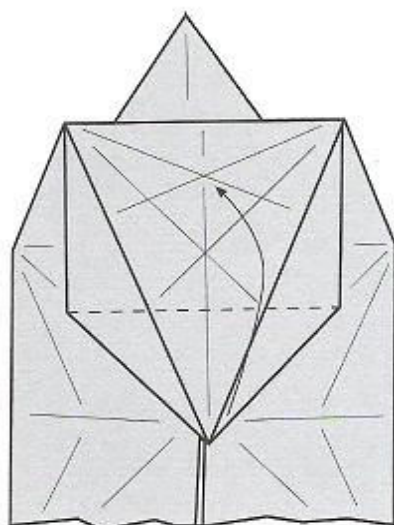

132

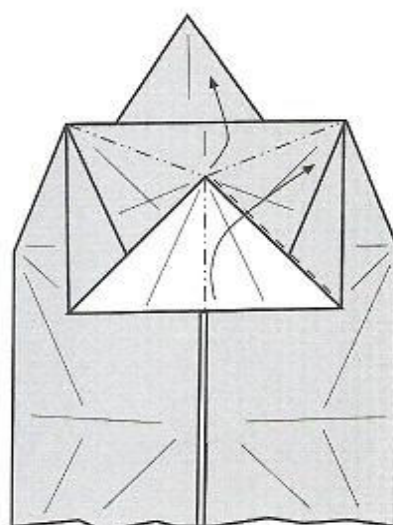

133

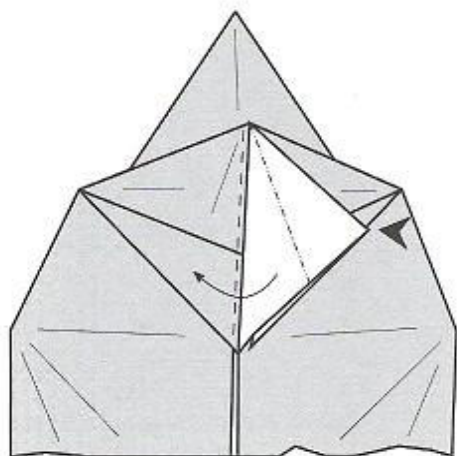

134

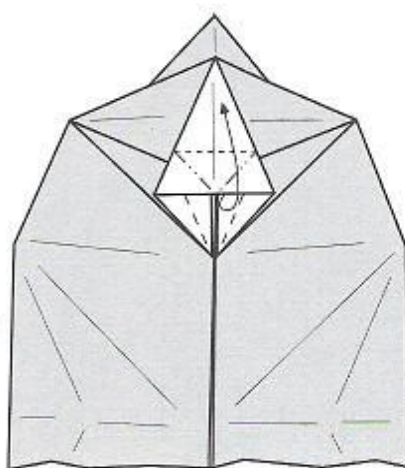

135

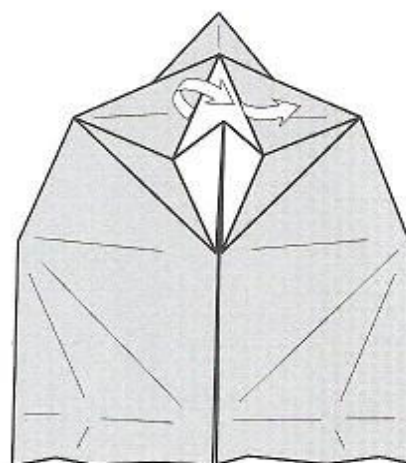

136

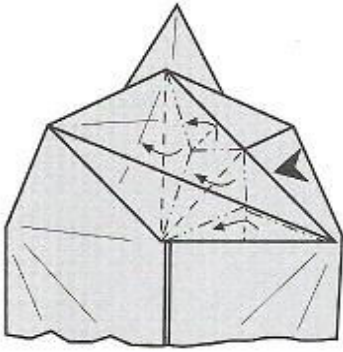

137

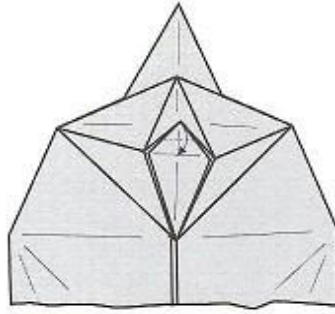

138

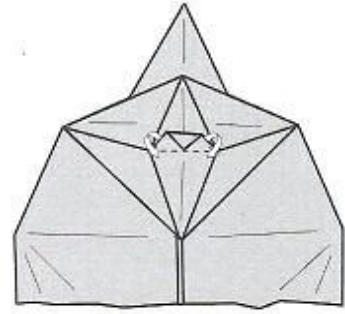

139

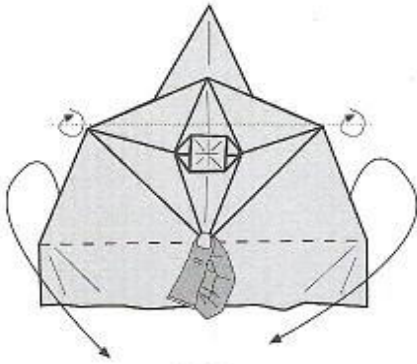

140

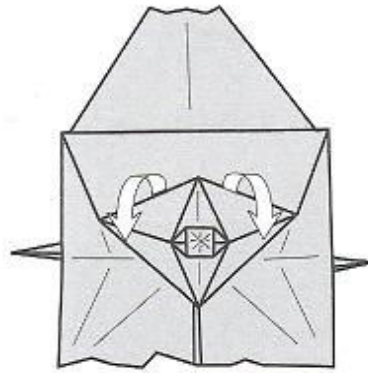

141

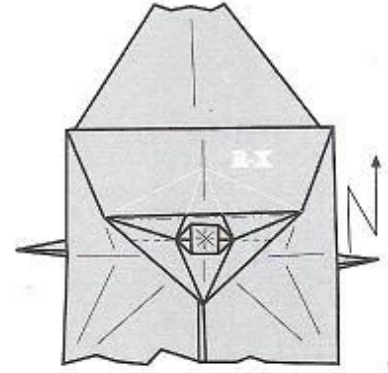

142

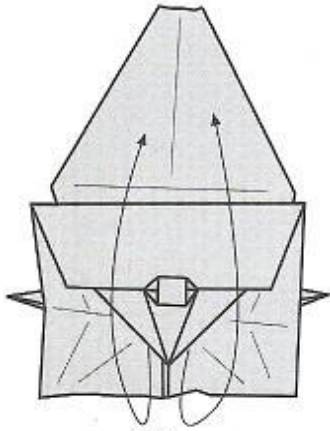

143

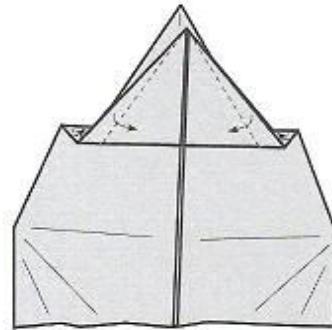

144

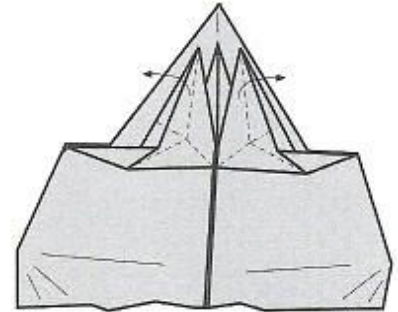

145

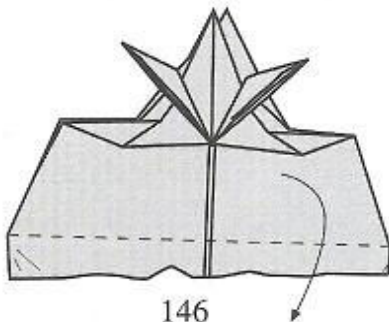

146

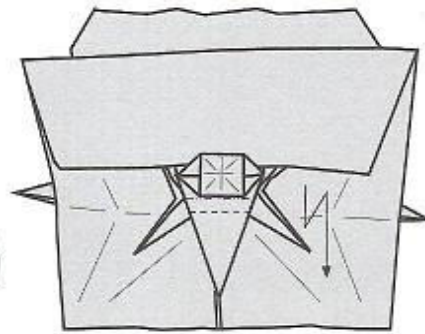

147

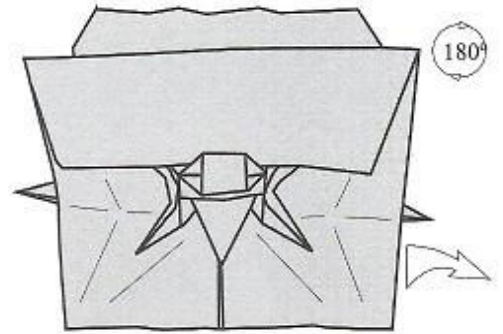

148

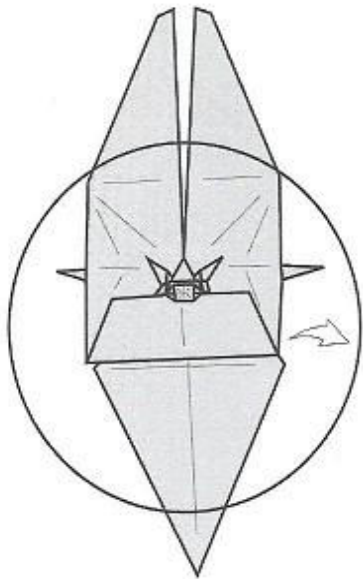

149

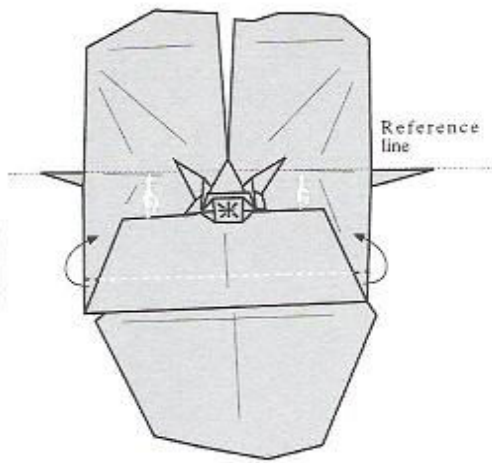

150

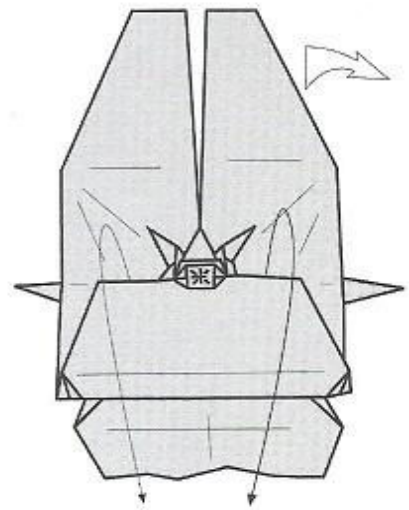

151

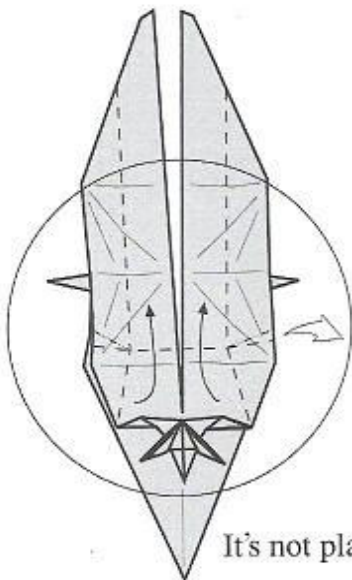

152

It's not plain

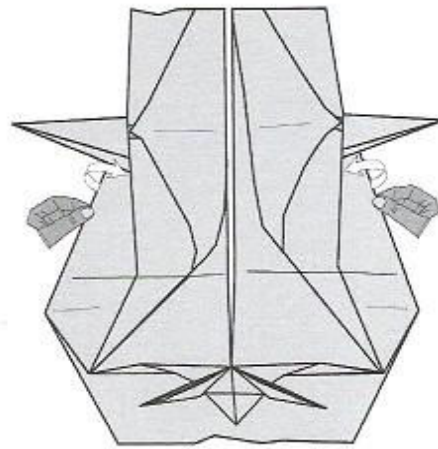

153

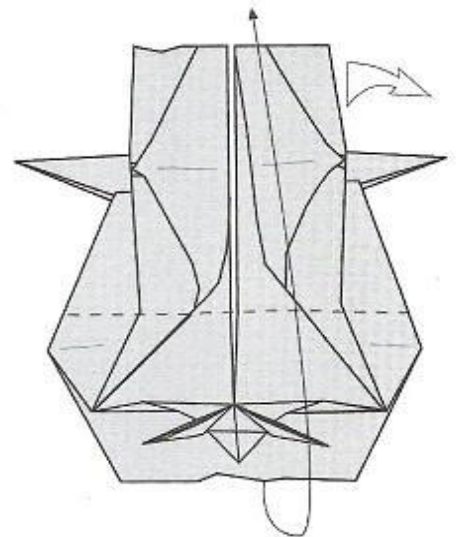

154

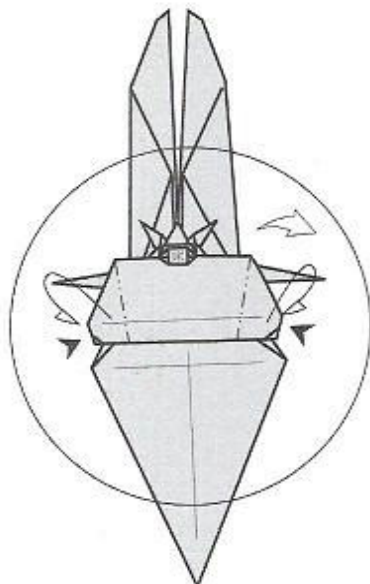

155

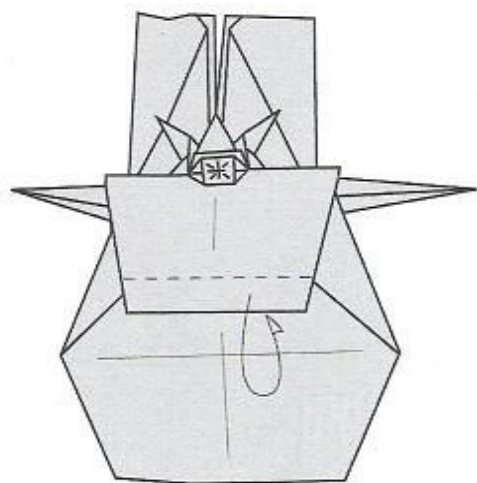

156

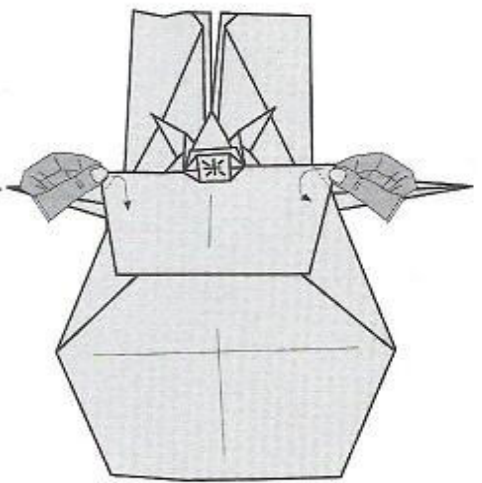

157

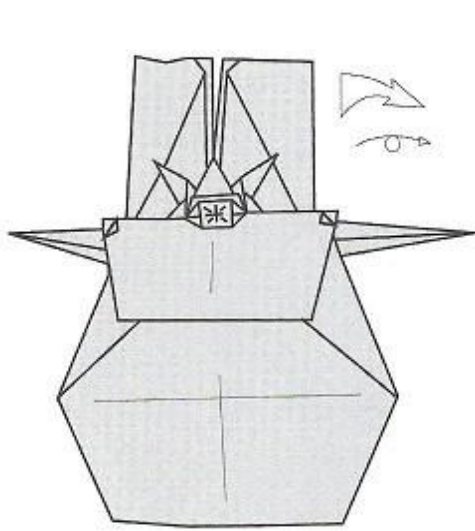

158

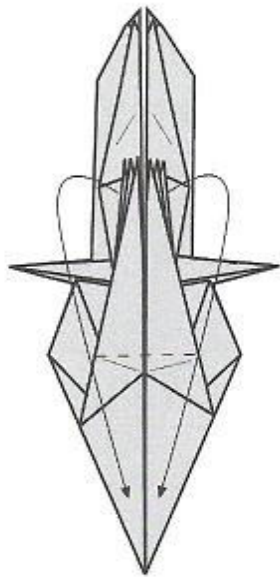

159

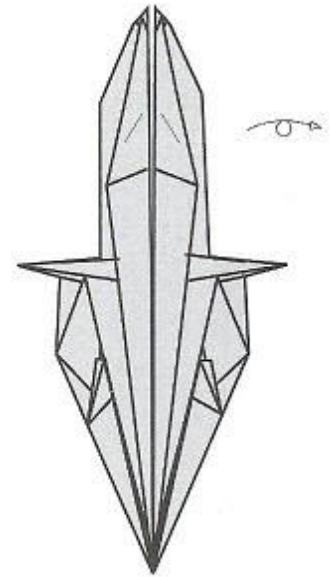

160

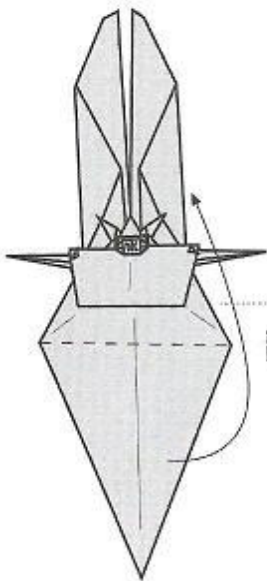

161

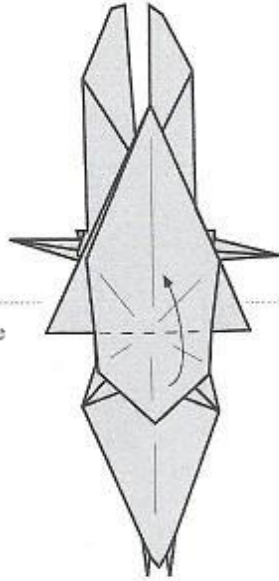

162

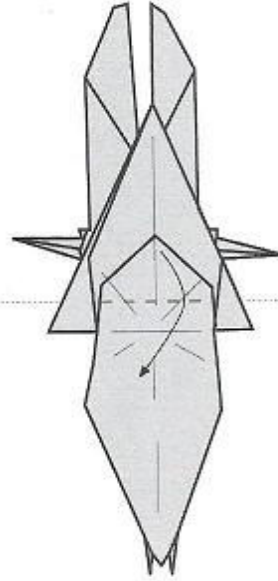

163

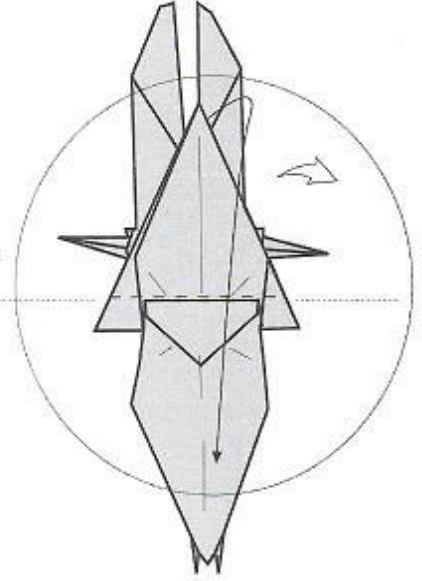

164

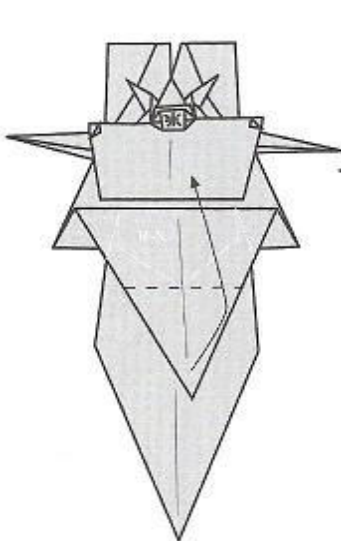

165

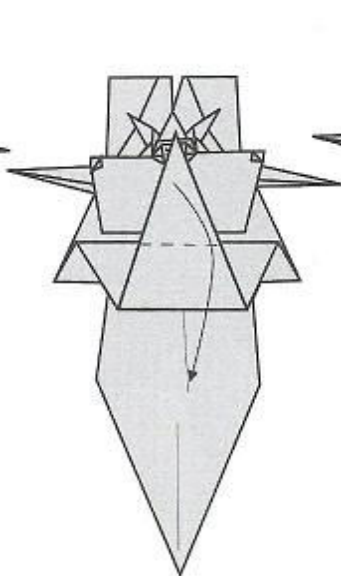

166

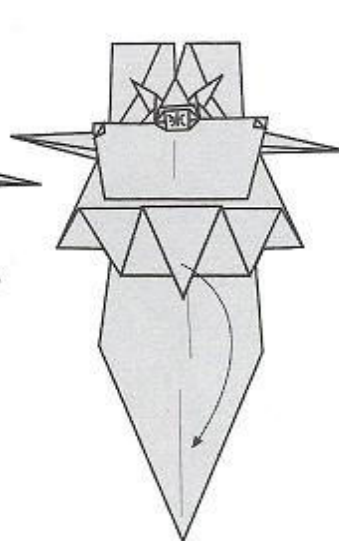

167

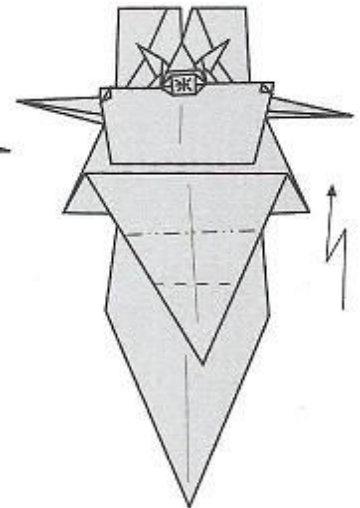

168

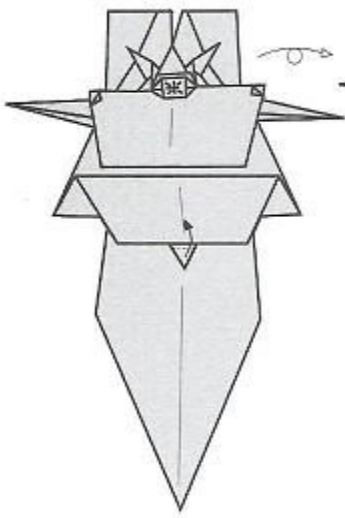

169

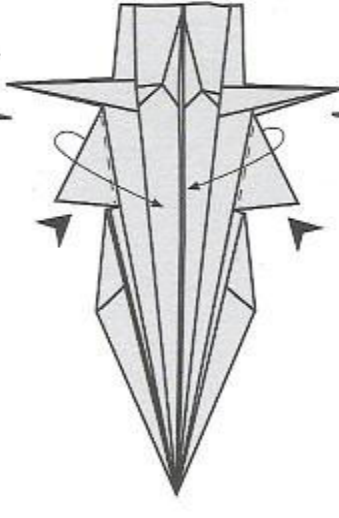

170

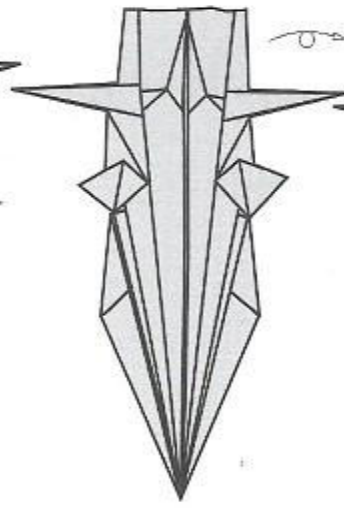

171

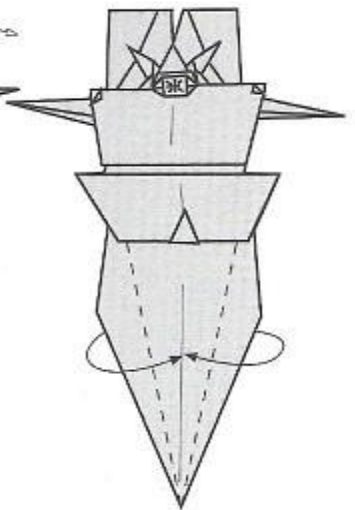

172

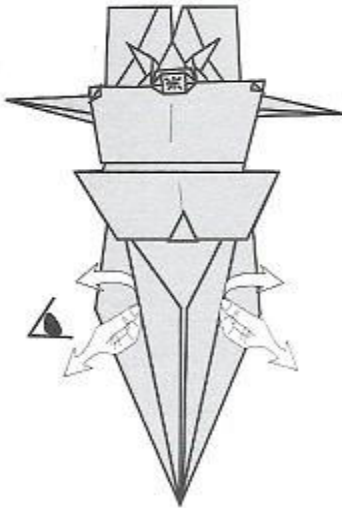

173

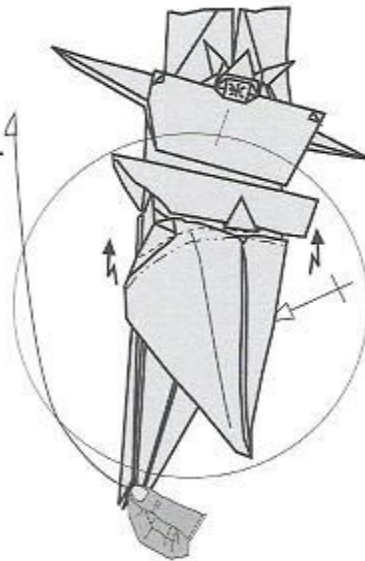

174

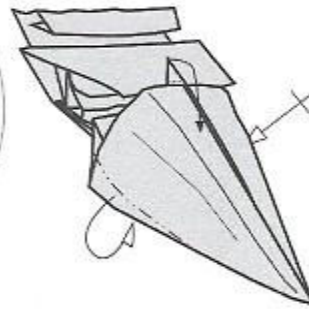

175

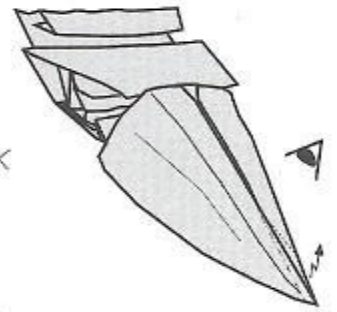

176

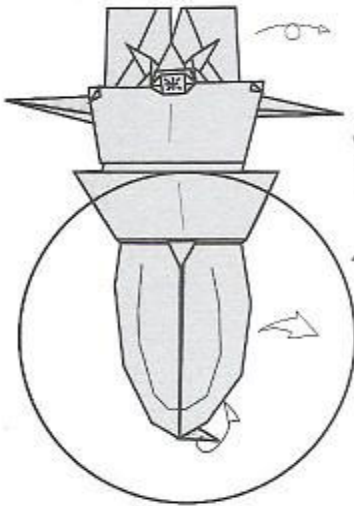

177

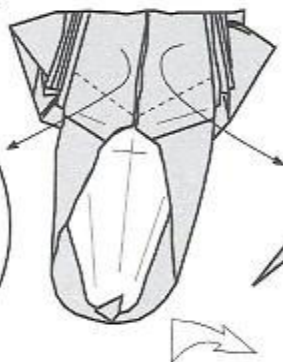

178

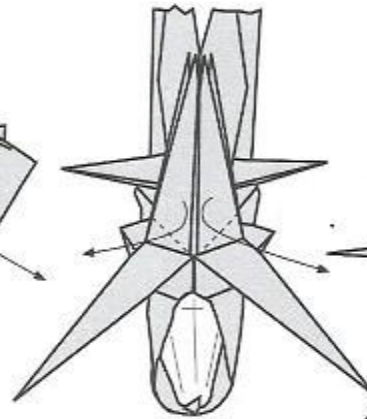

179

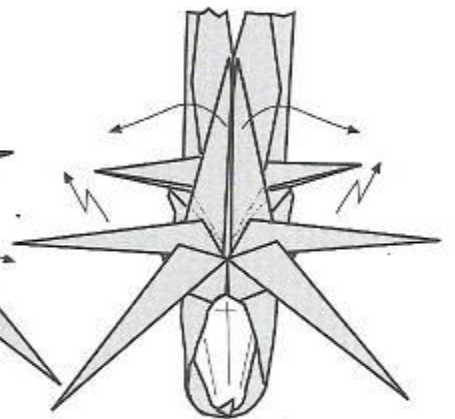

180

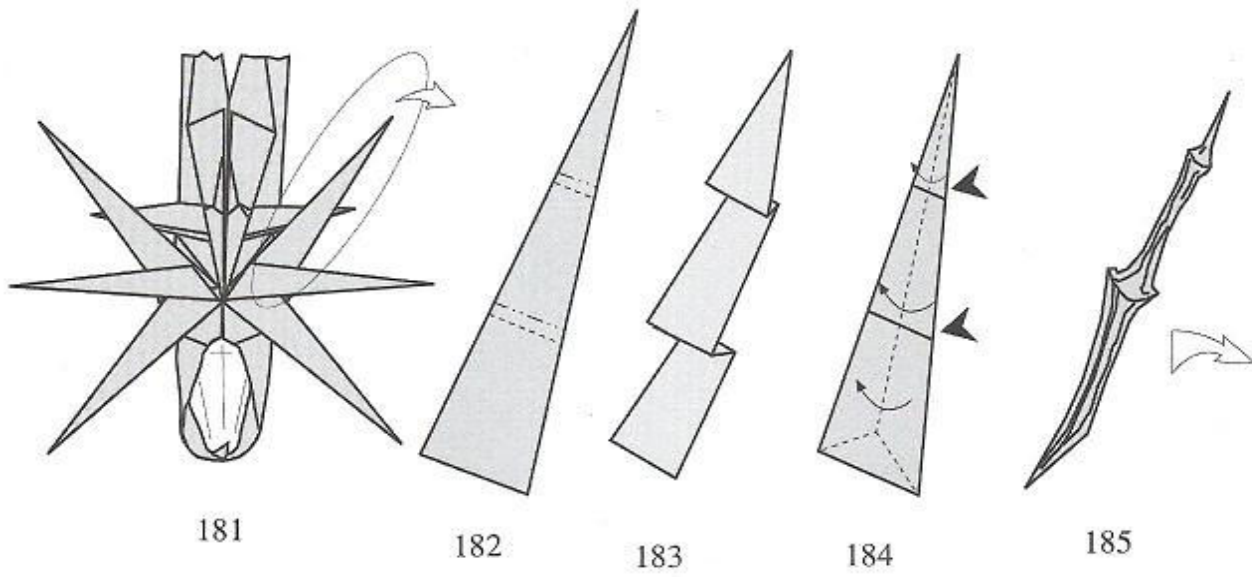

181

182

183

184

185

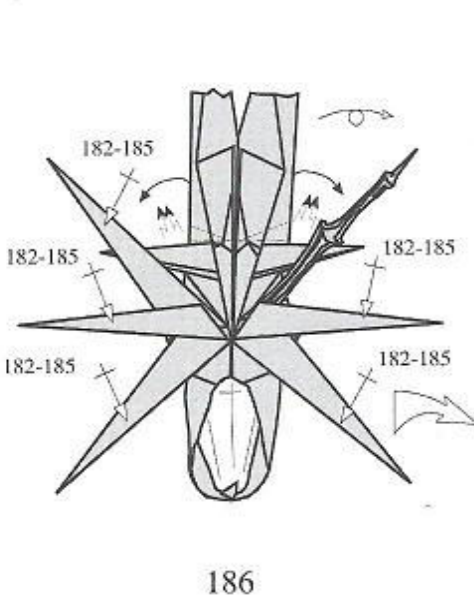

186

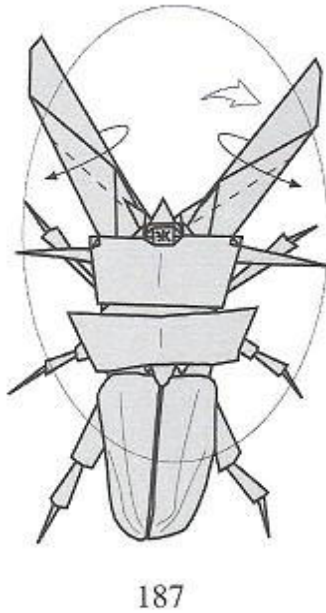

187

The legs will be omitted until the end.

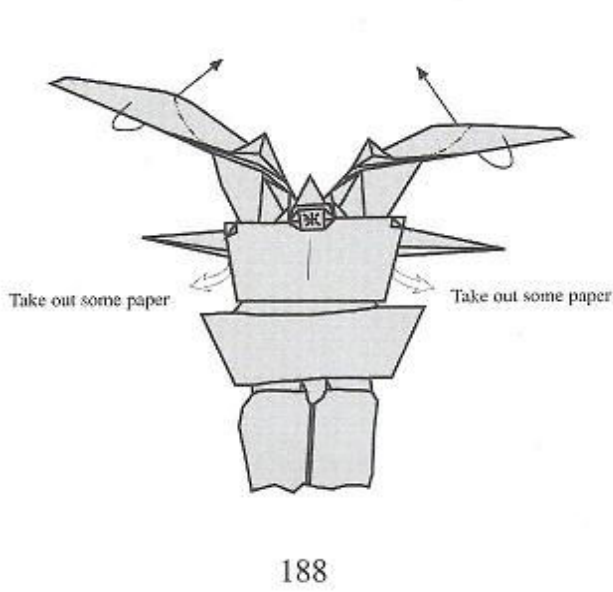

188

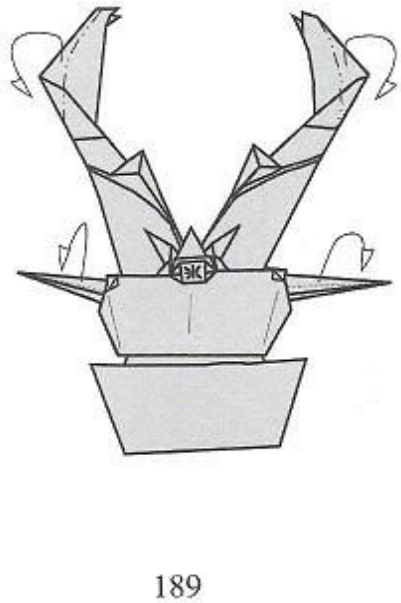

189

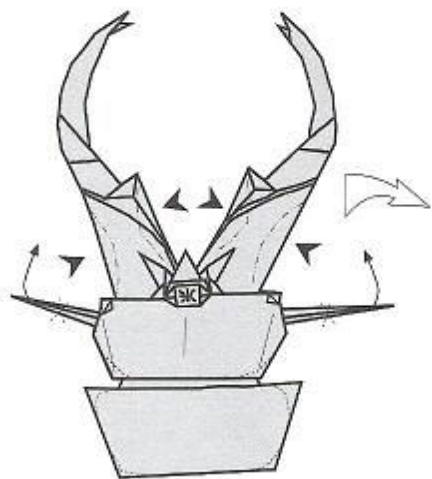

190

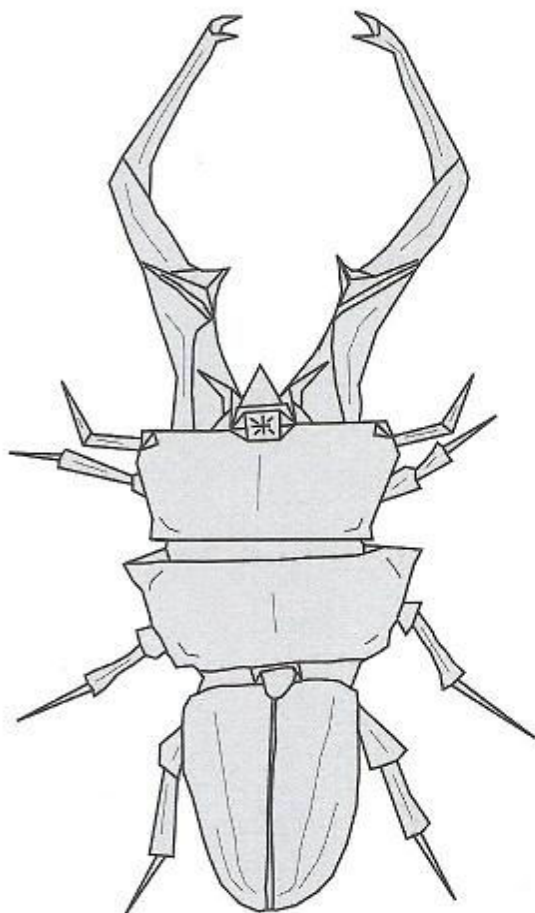

191

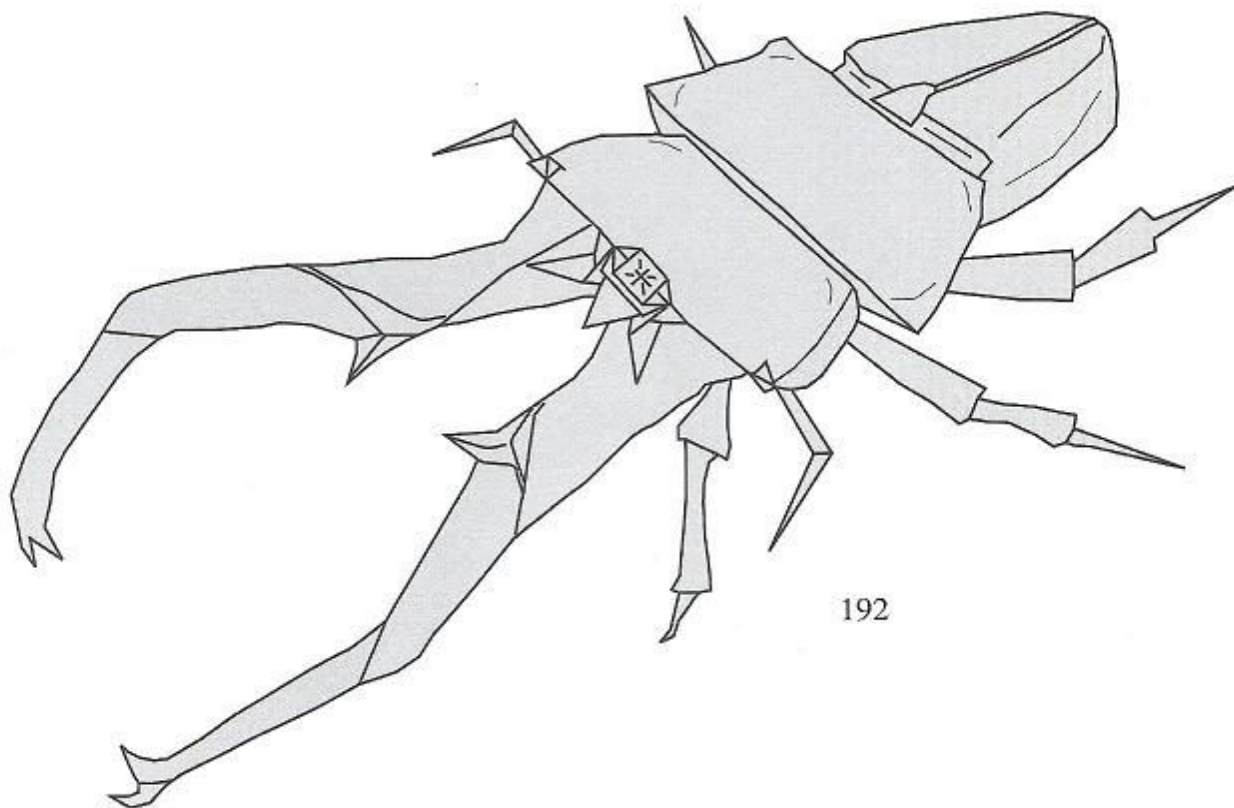

192

European Stag Beetle

(*Lucanus cervus*)

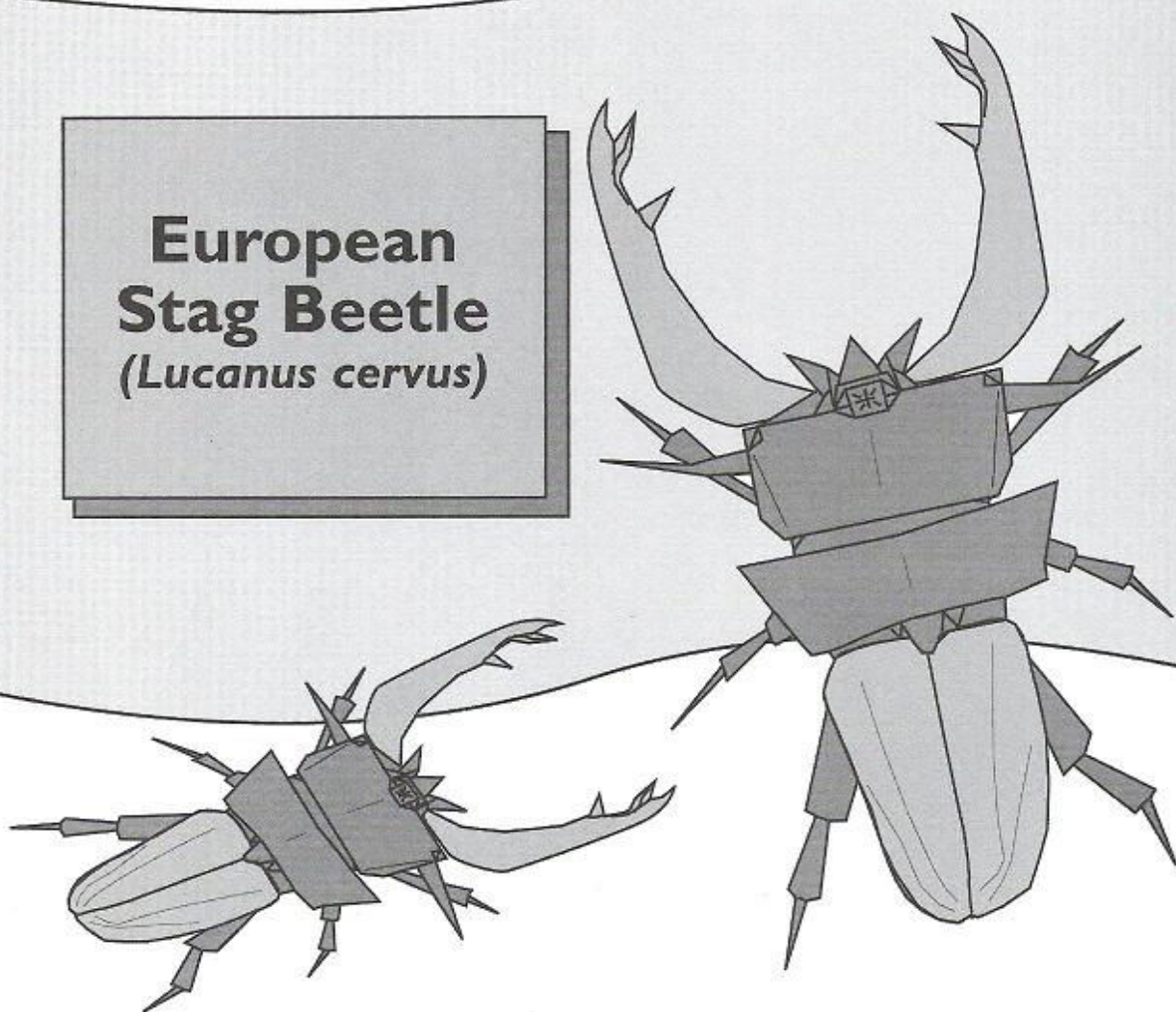

The paper should be dark brown and black. Fine paper is recommended, less than 40 grams, double silk, banana tree, lokta, metallic or "sandwich," 13.75x13.75 inches (35x35 cm) or bigger.

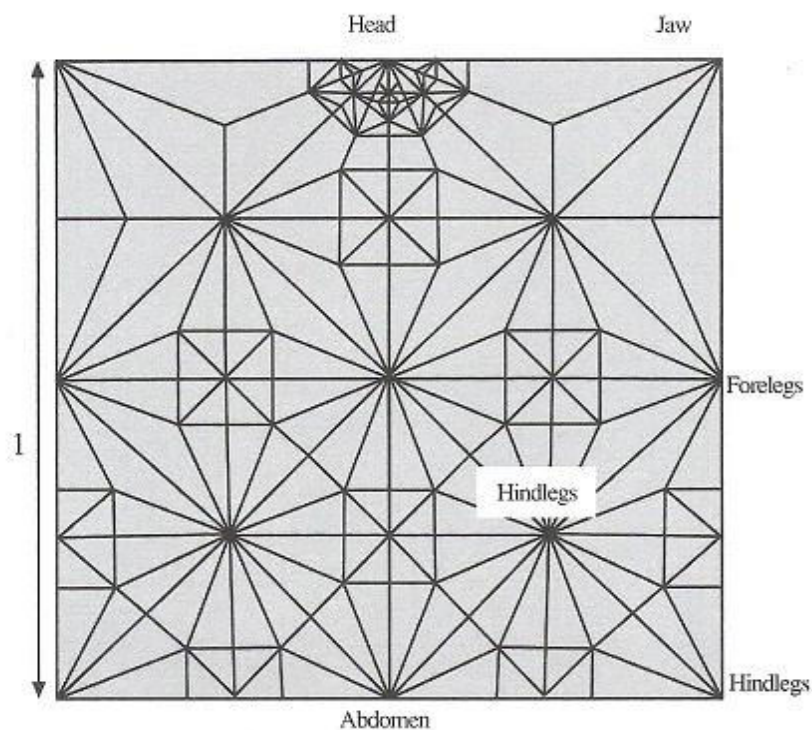
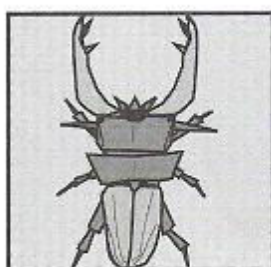

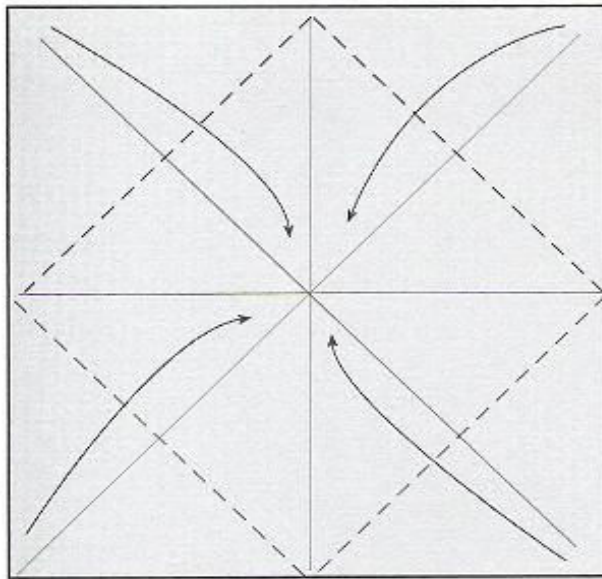

steps 2 until 65 of *Cyclommatus imperator*



1  black
dark brown

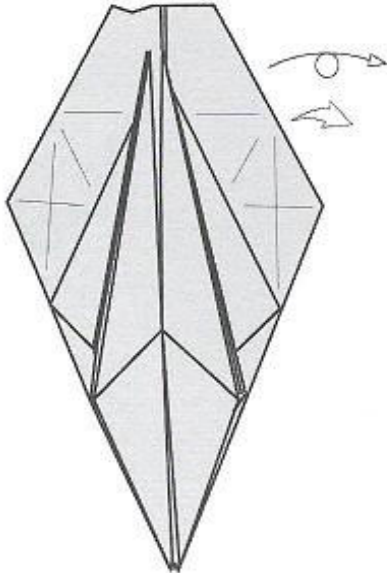

step 66 of *Cyclommatus imperator*

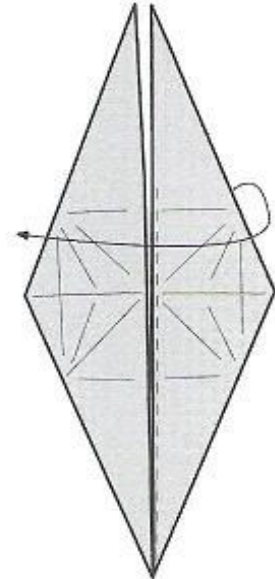

67

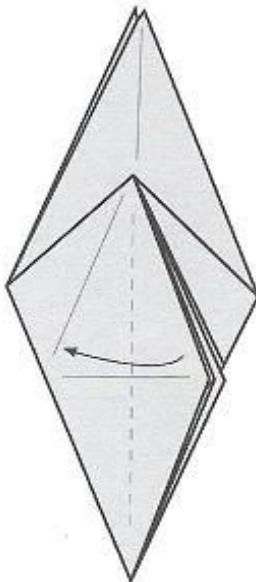

68

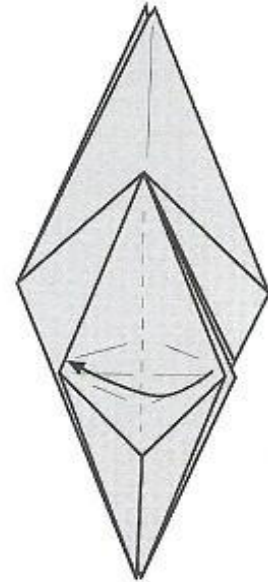

69

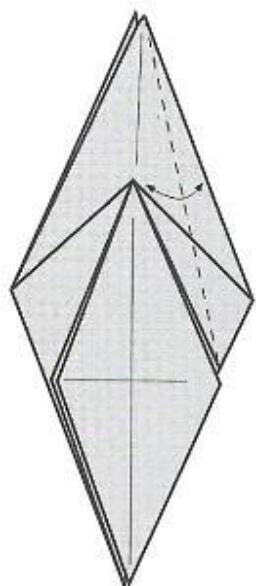

70

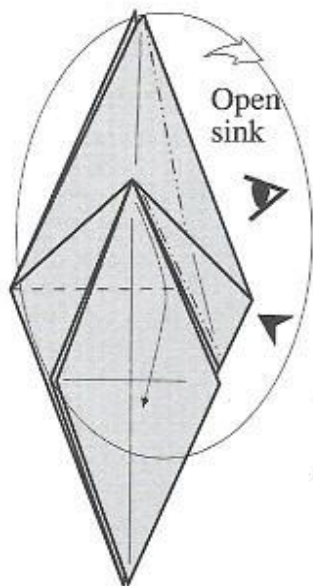

71

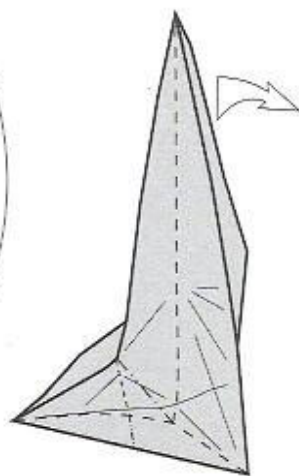

72-3D

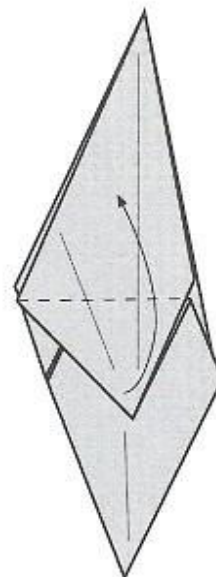

73

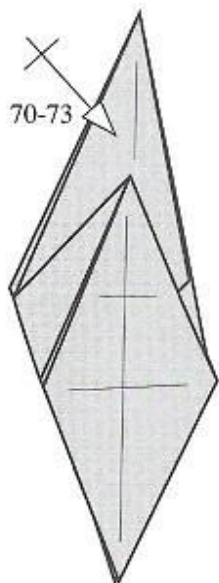

74

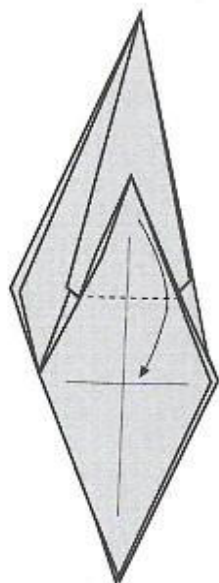

75

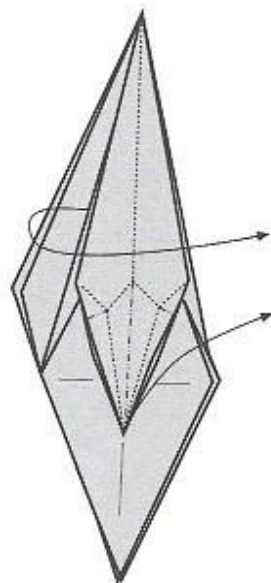

76

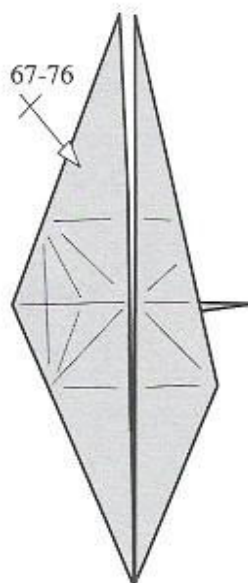

77

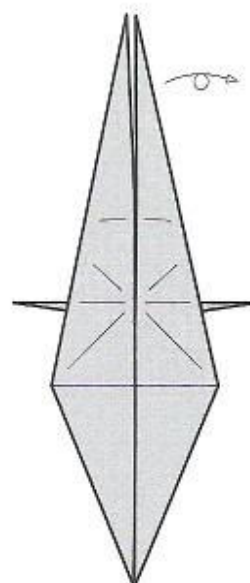

78

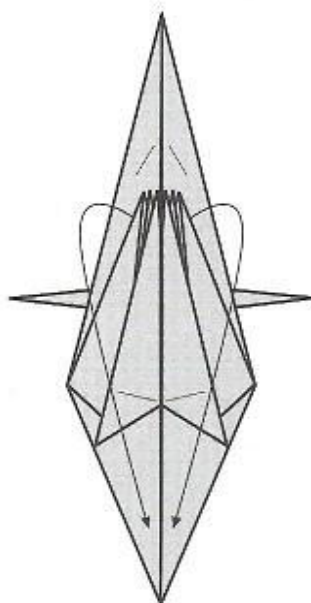

79

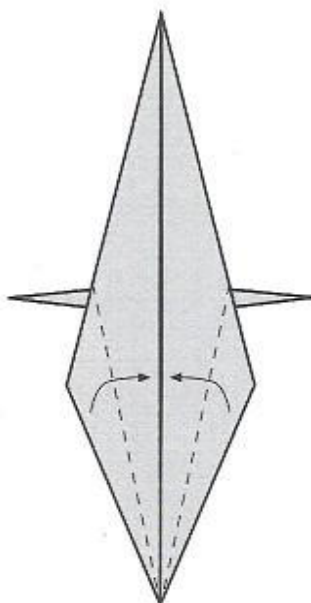

80

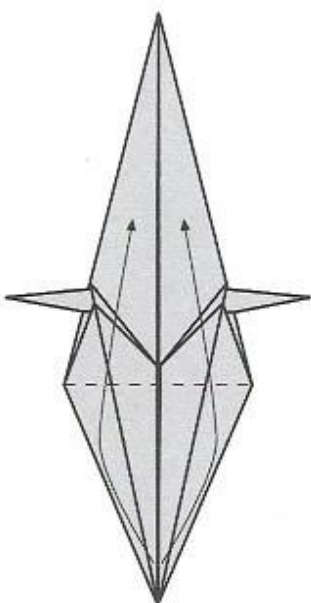

81

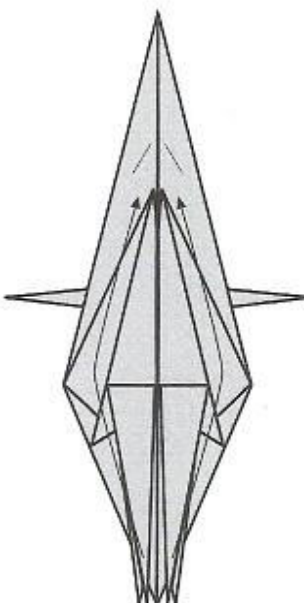

82

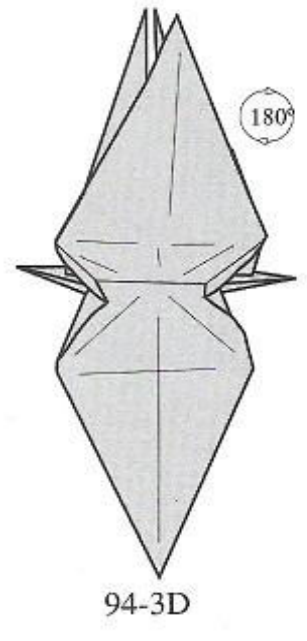
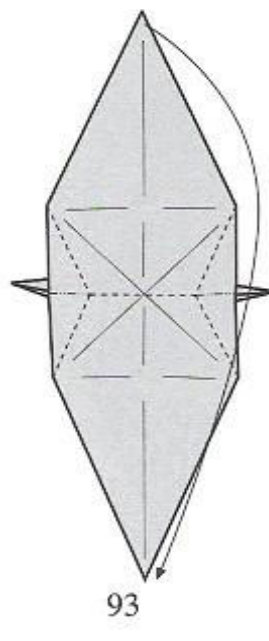
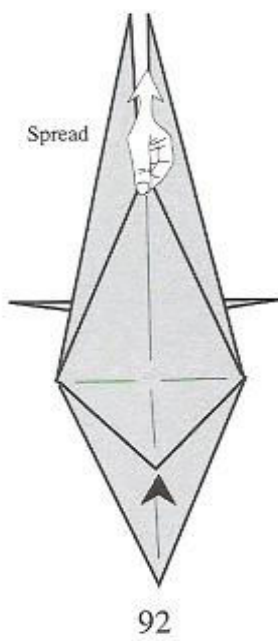
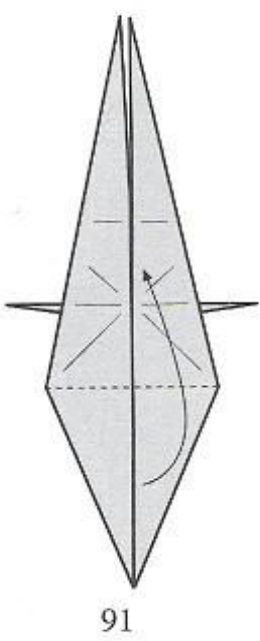
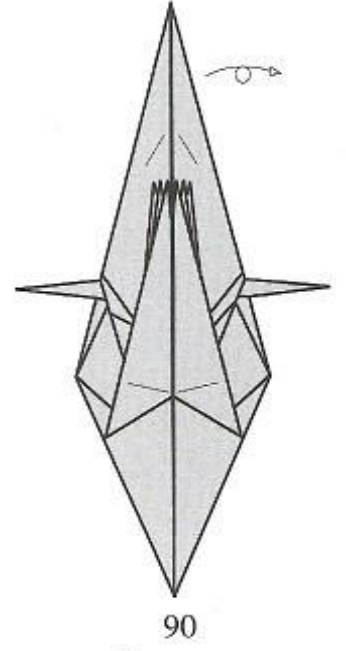
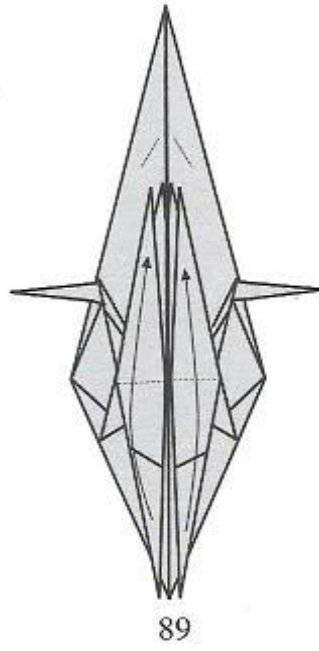
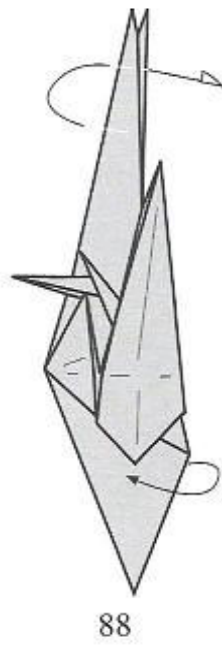
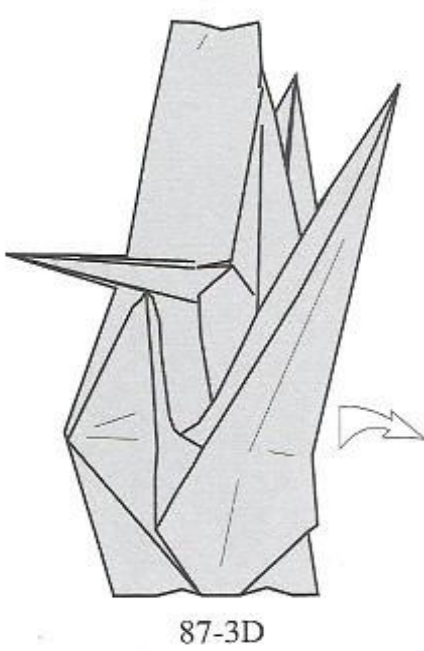
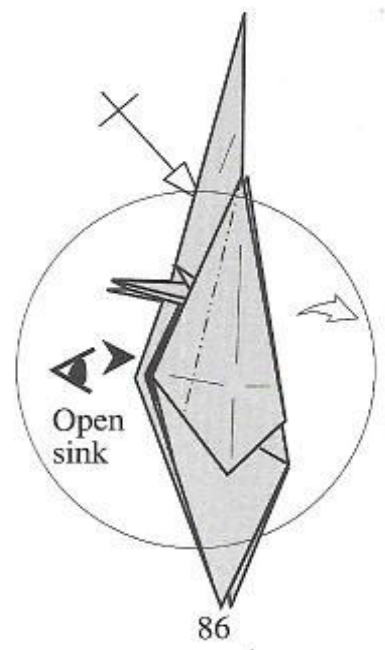
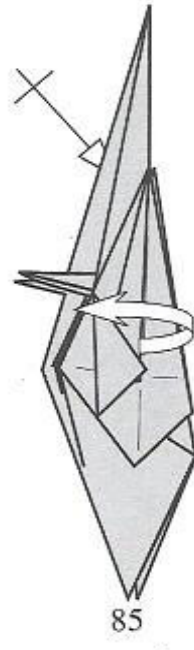
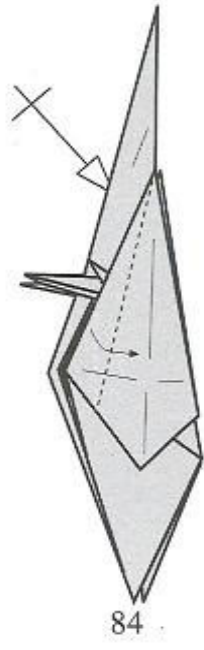
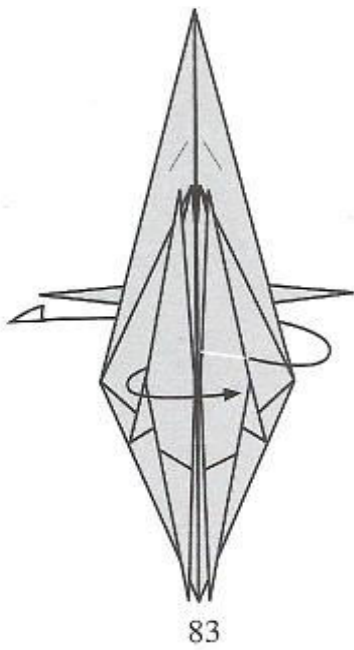

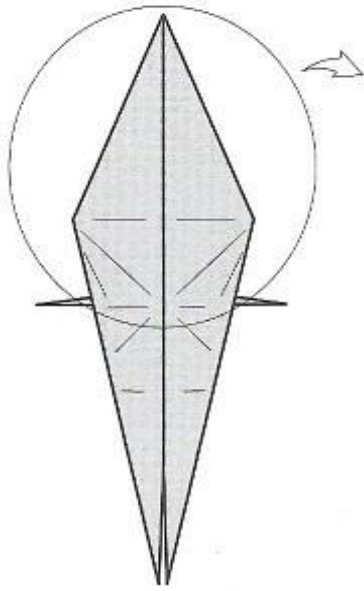

95

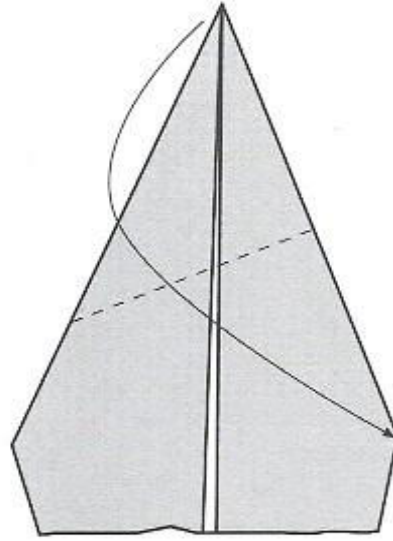

96

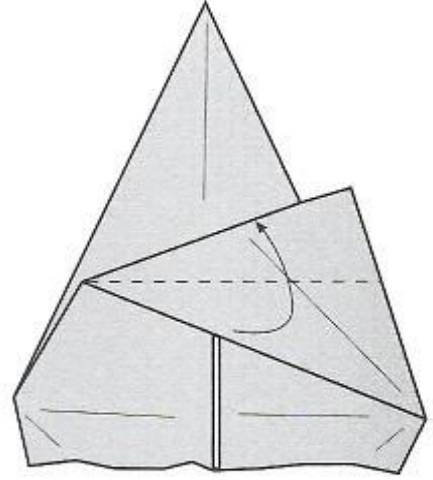

97

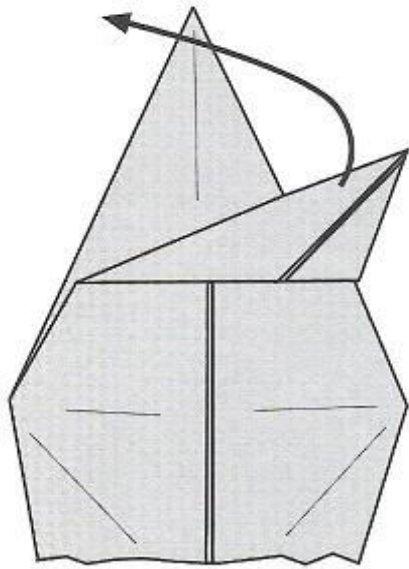

98

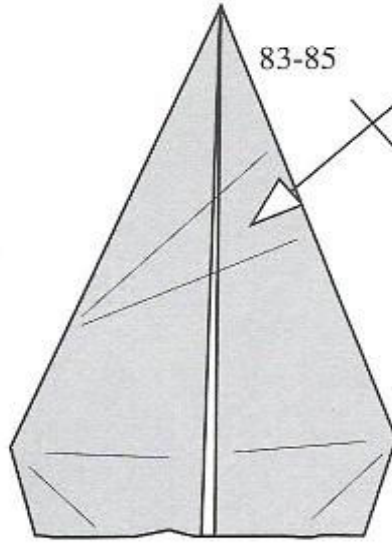

99

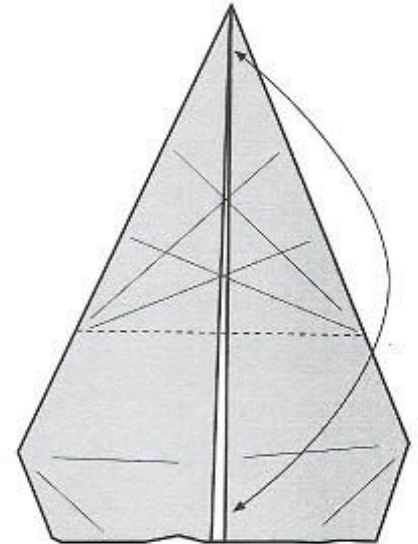

100

Two layers

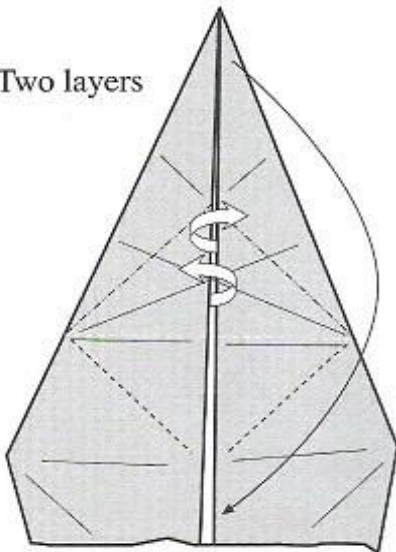

101

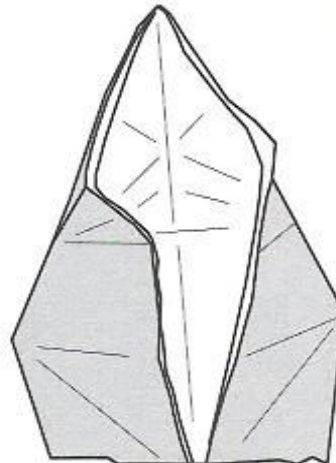

102-3D

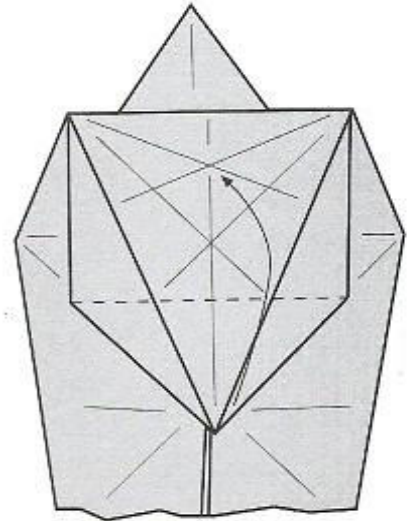

103

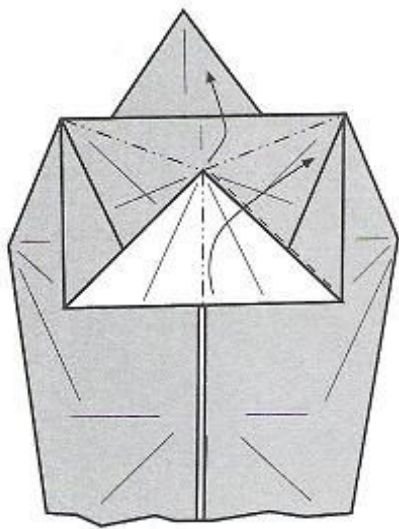

104

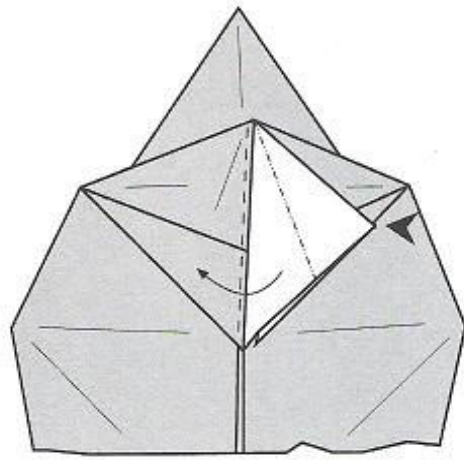

105

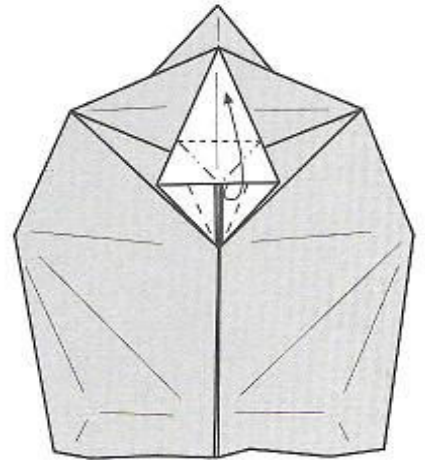

106



107

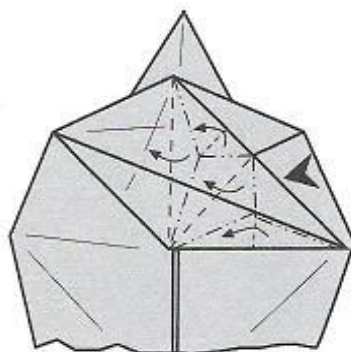

108

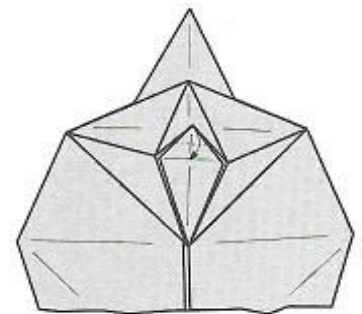

109

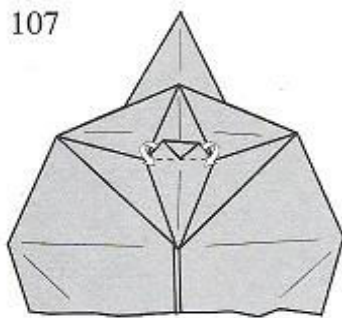

110

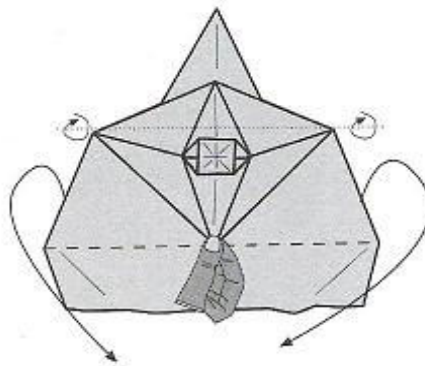

111

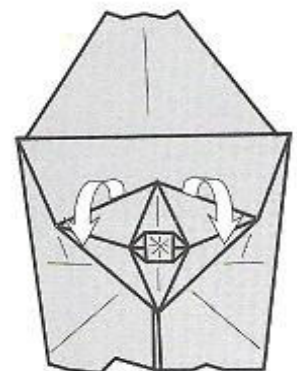

112

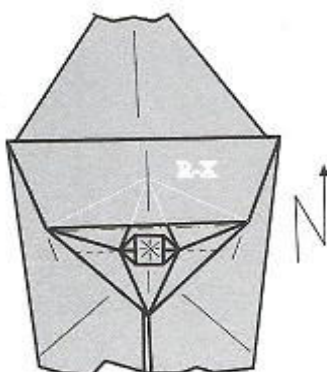

113

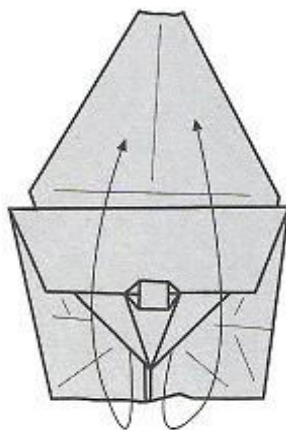

114

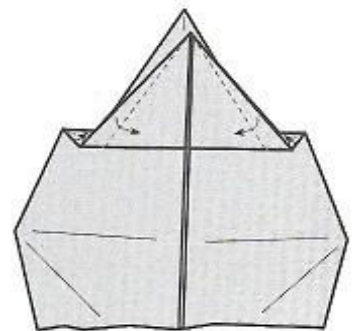

115

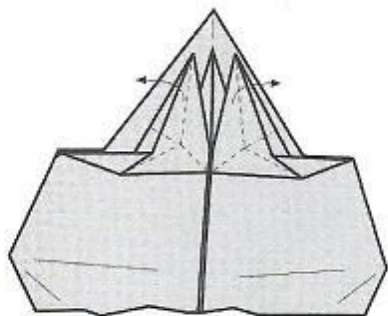

116

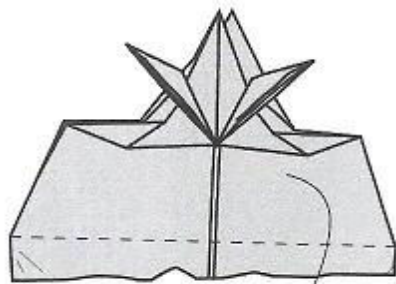

117

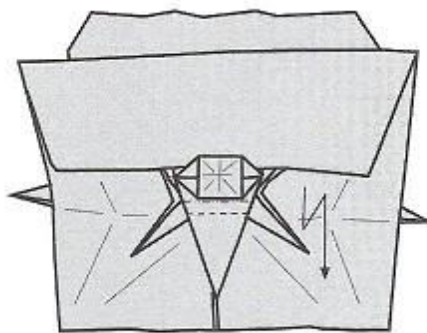

118

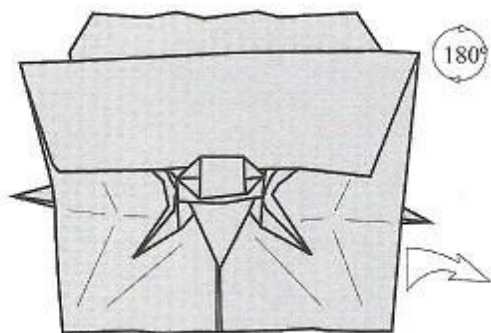

119

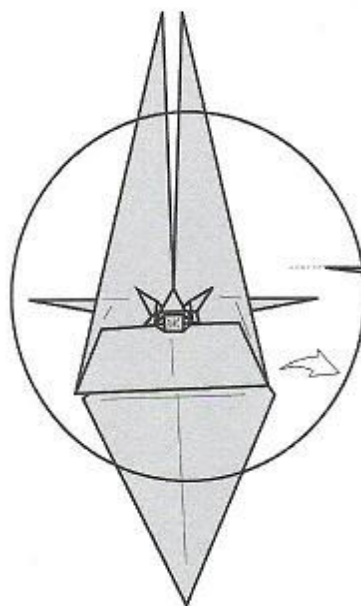

120

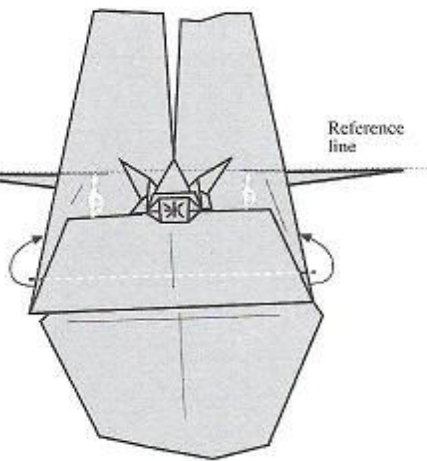

121

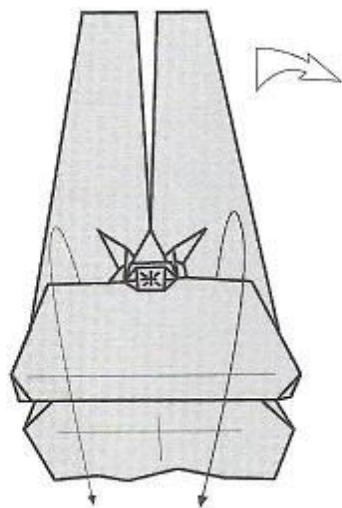

122

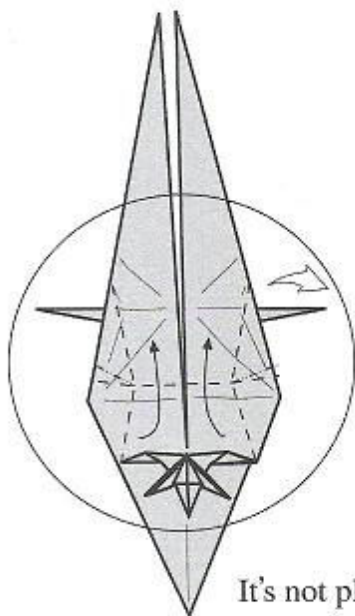

123

It's not plain

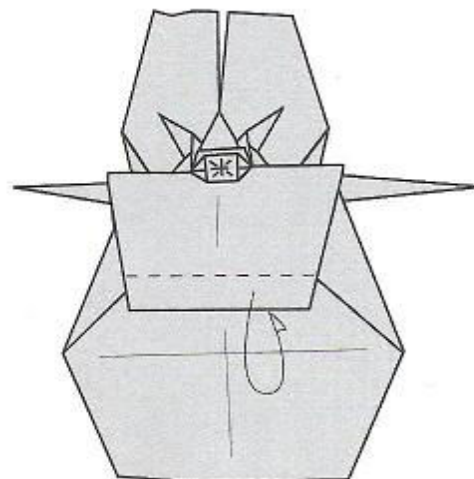

124

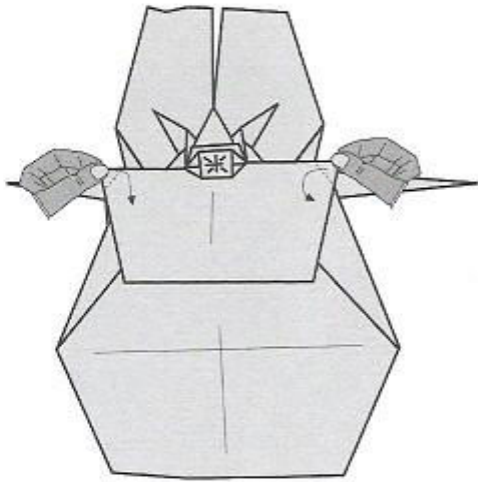

125

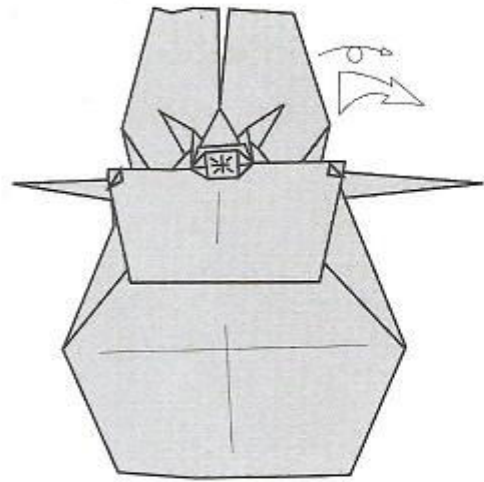

126

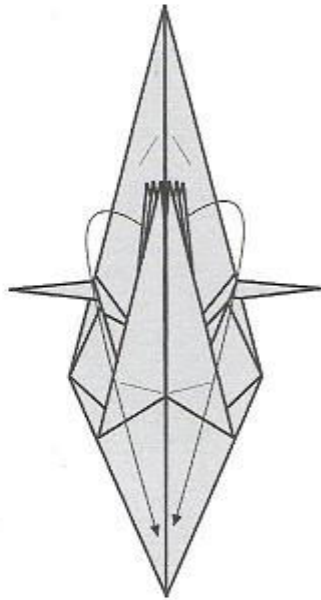

127

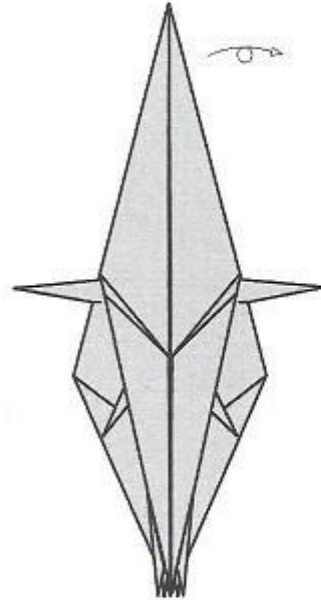

128

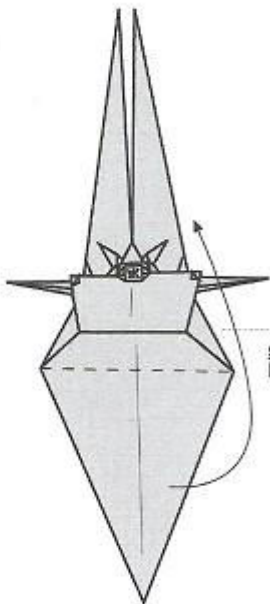

129

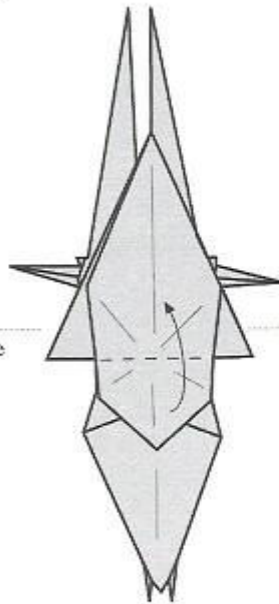

130

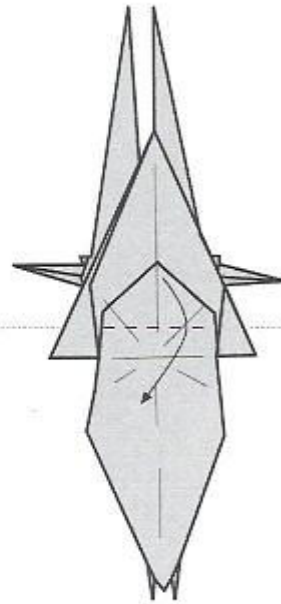

131

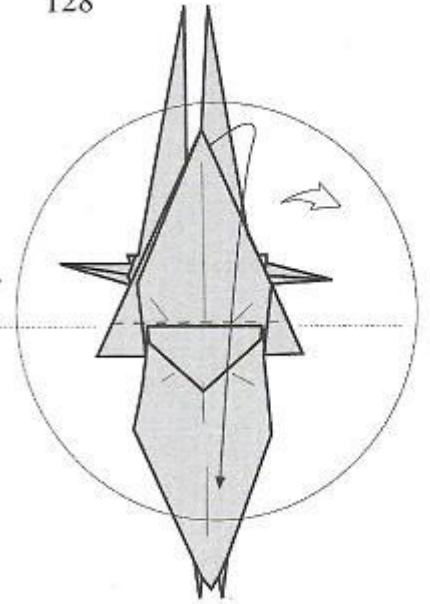

132

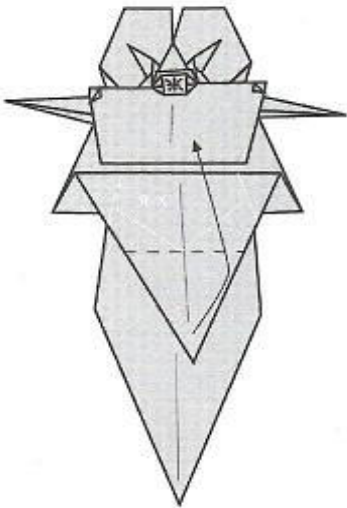

133

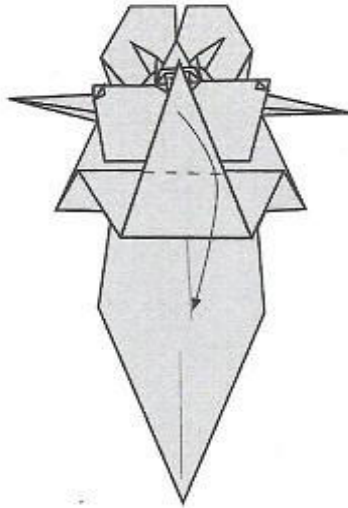

134

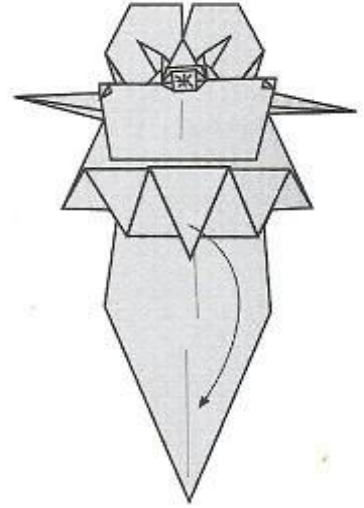

135

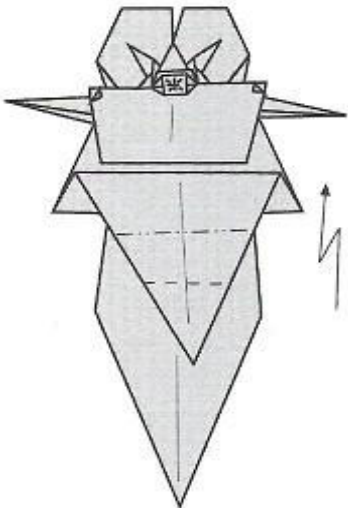

136

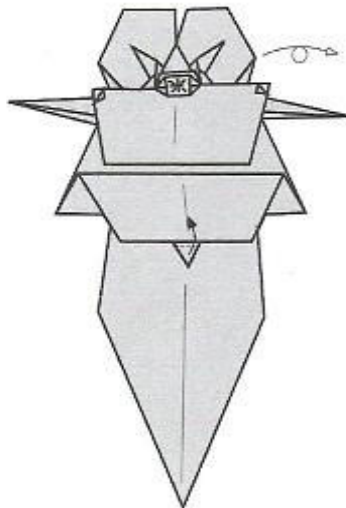

137

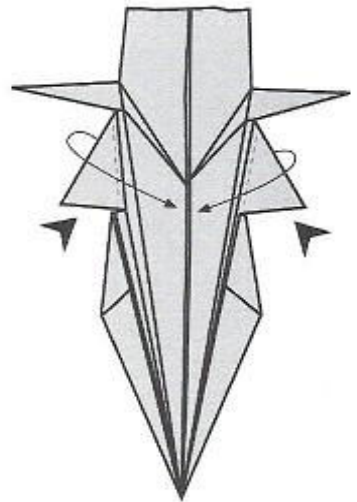

138

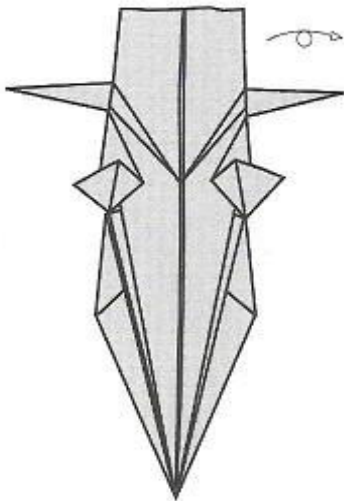

139

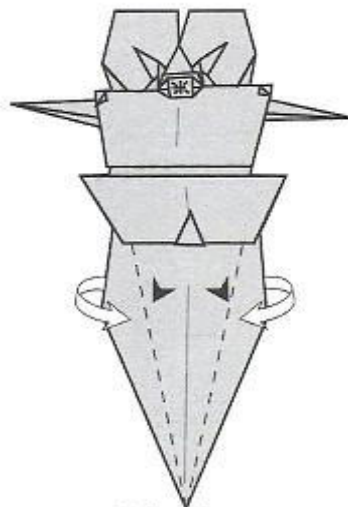

Color change

140

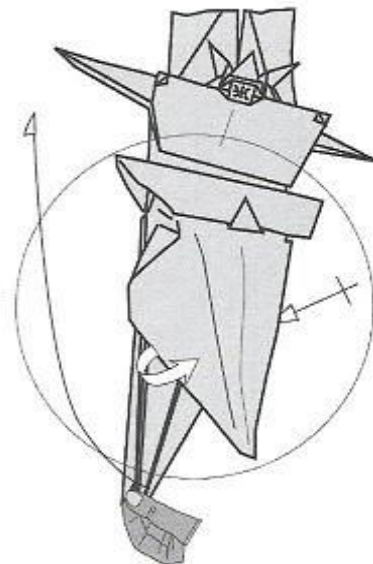

141-3D

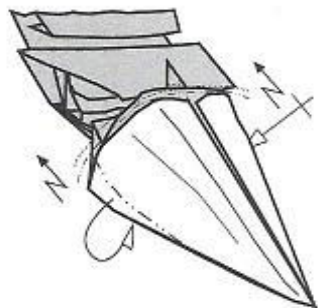

142

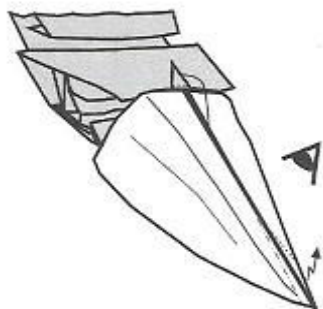

143

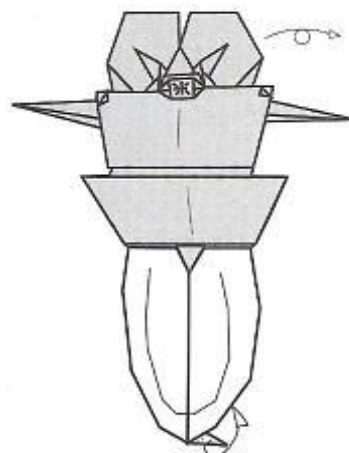

144

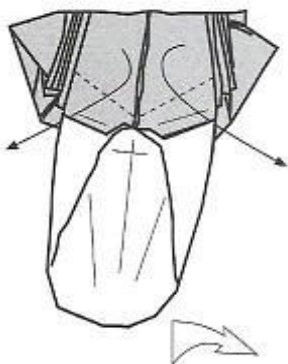

145

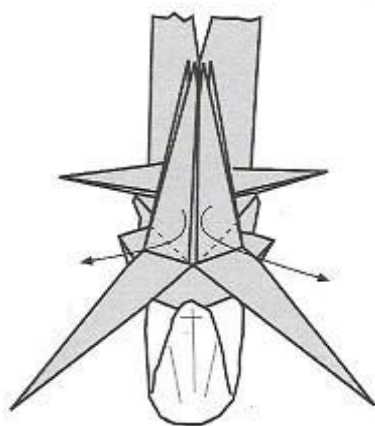

146

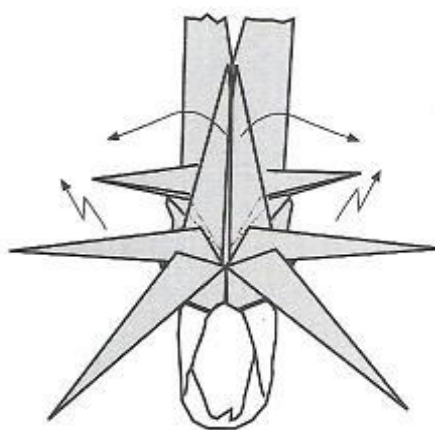

147

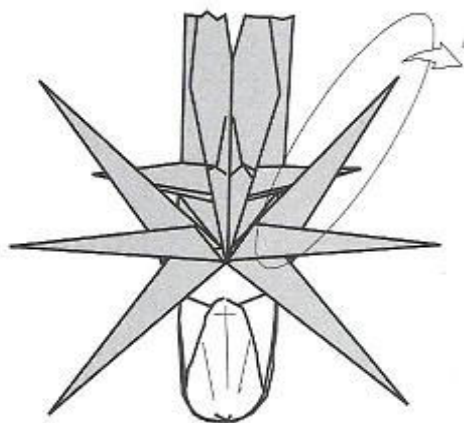

148



149

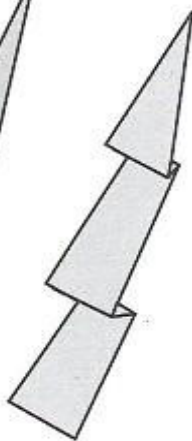

150

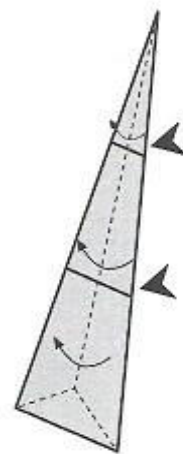

151



152

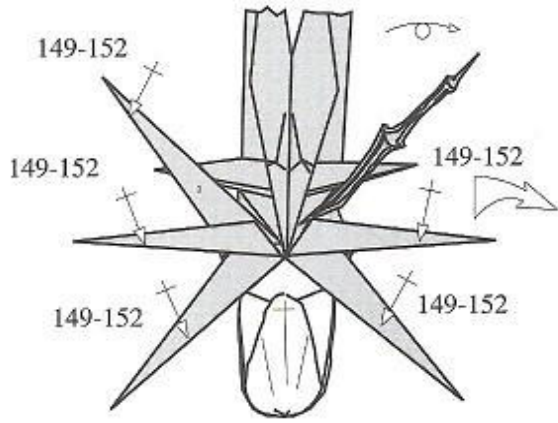

153

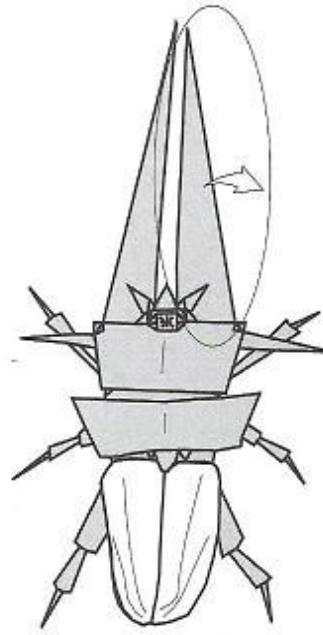

154

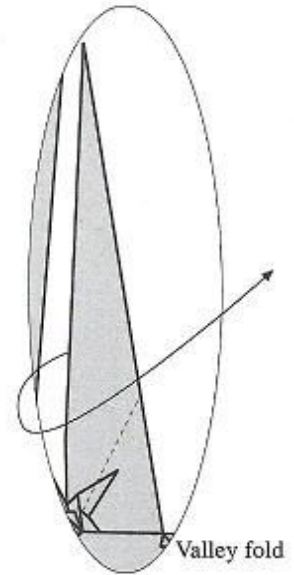

155

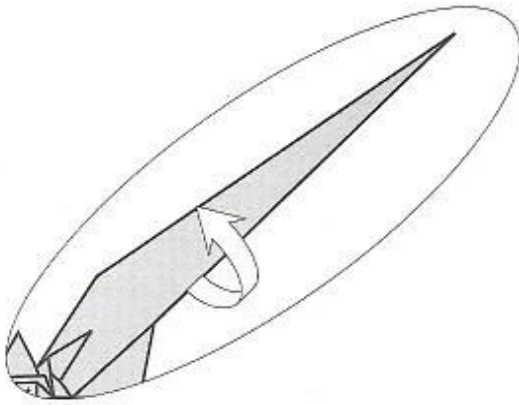

156

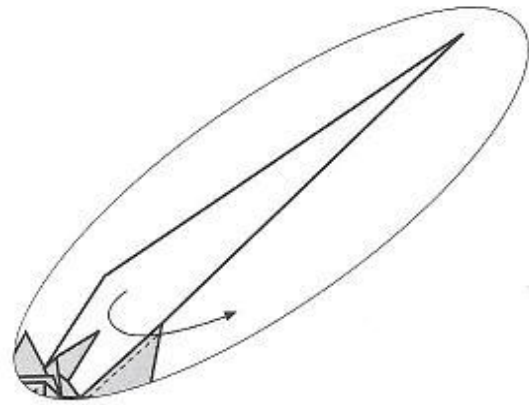

157

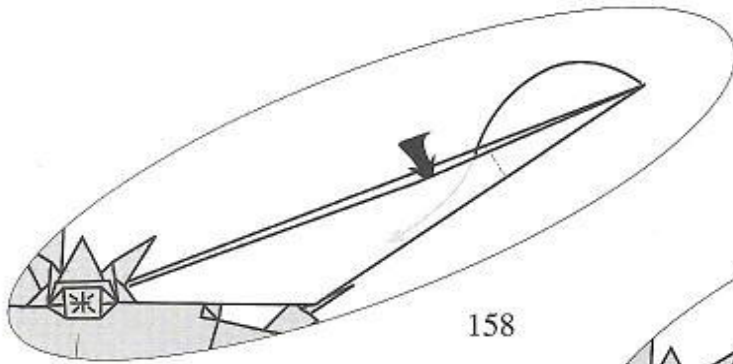

158

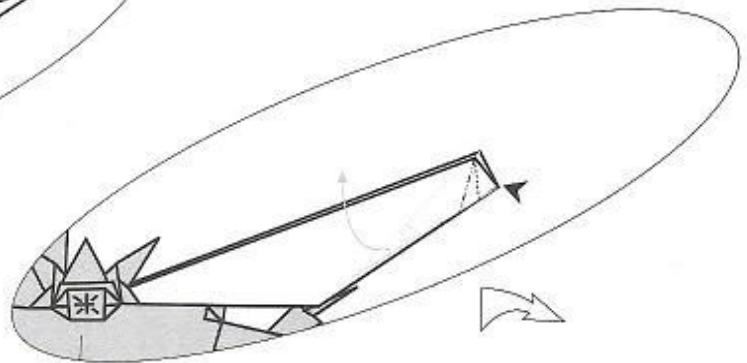

159

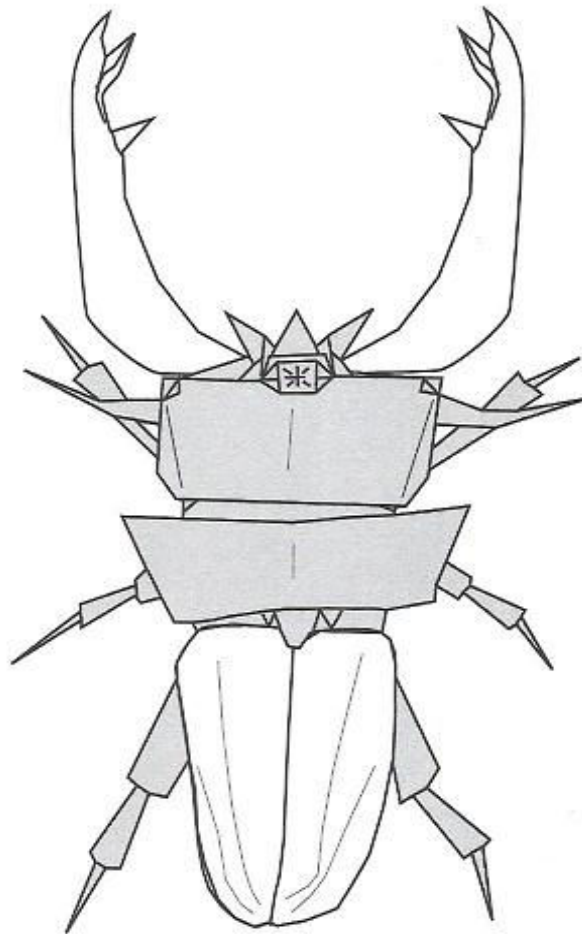
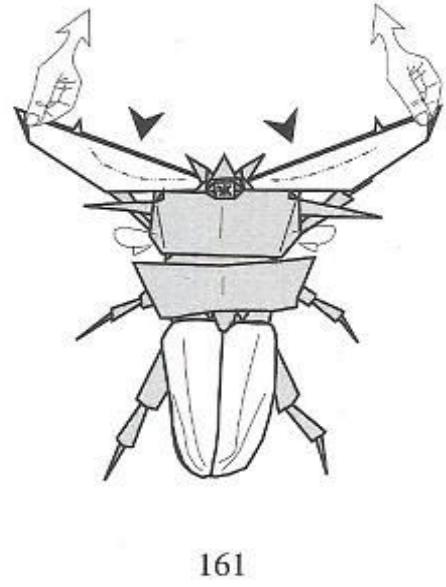
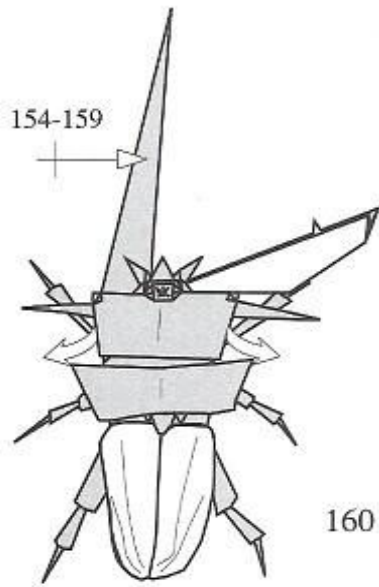

**Rhinoceros
Beetle flying**
(*Dynastes neptunus*)

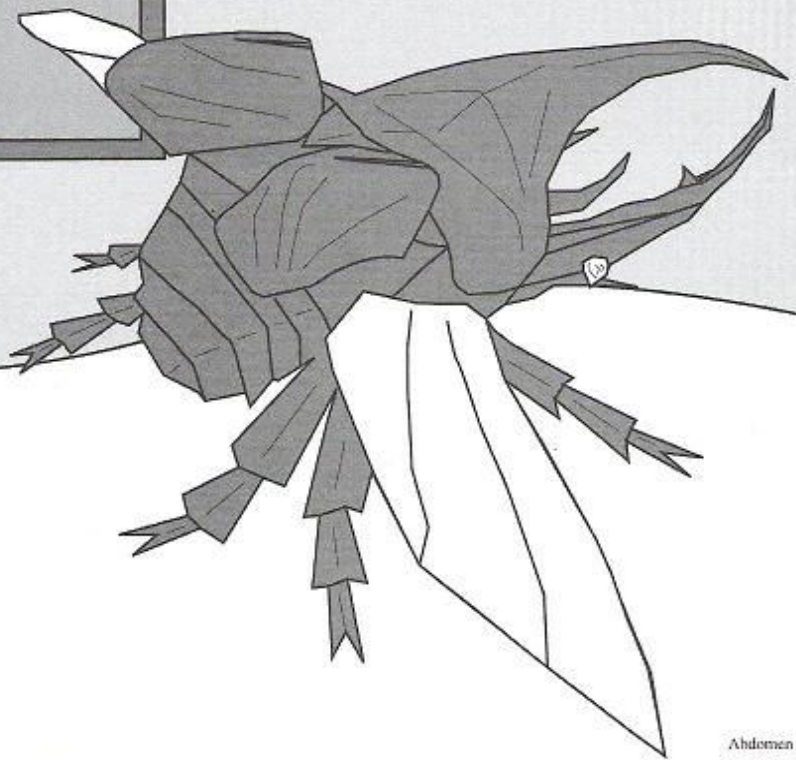

The paper should be dark (black or bluish black) for the body and yellow or white for the wings. Thin paper (tissue or tissue-foil) of dimensions 7.9x7.9 inches (20x20 cm) or greater is recommended.

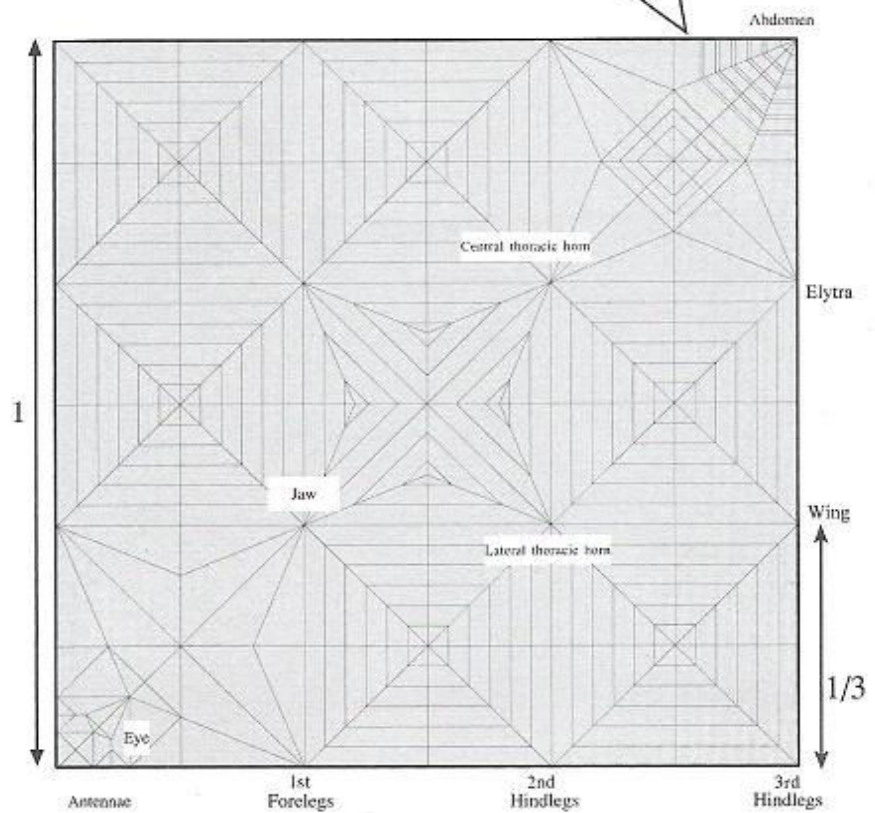
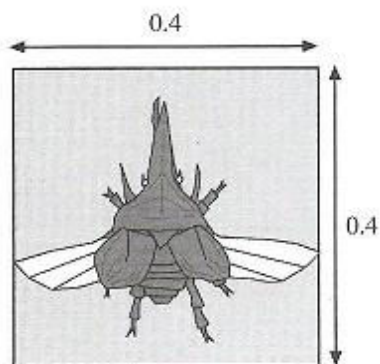

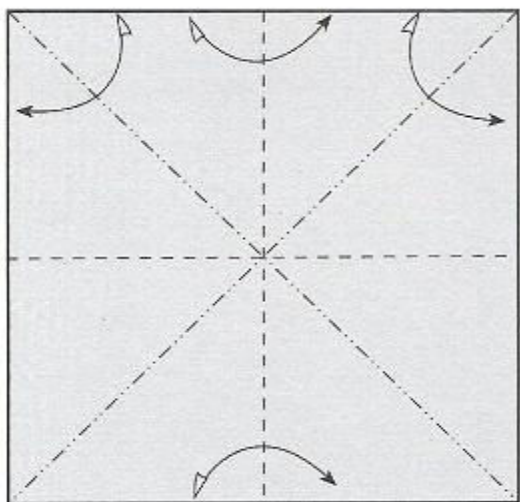

1 ⊖

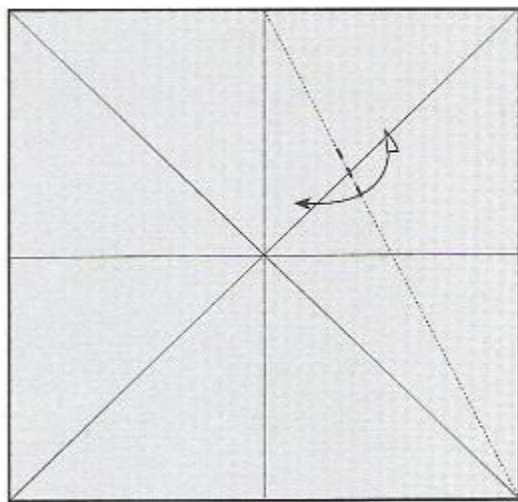

2

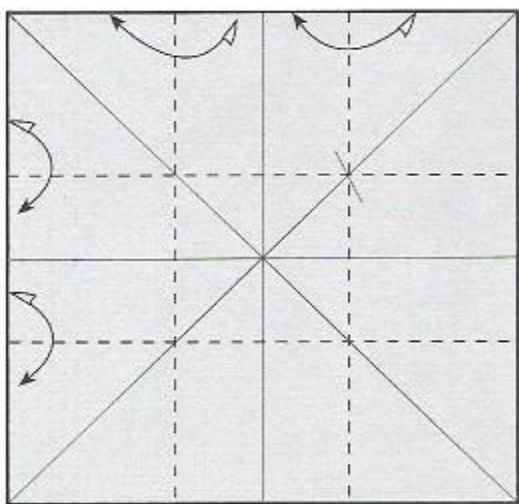

3

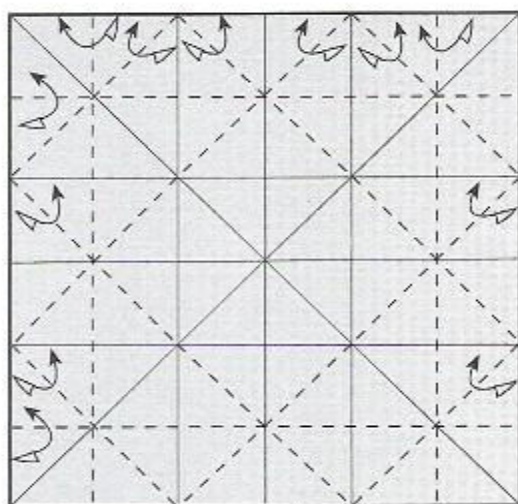

4

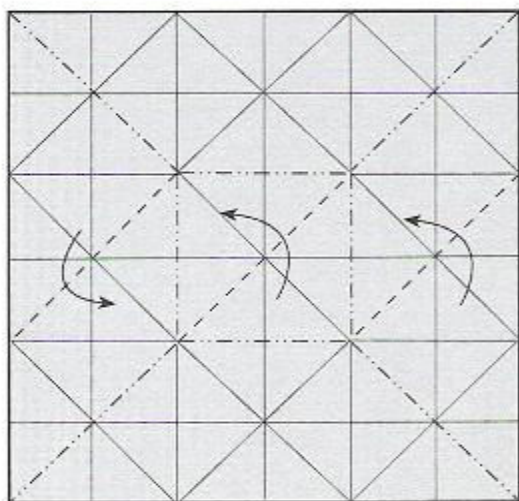

5

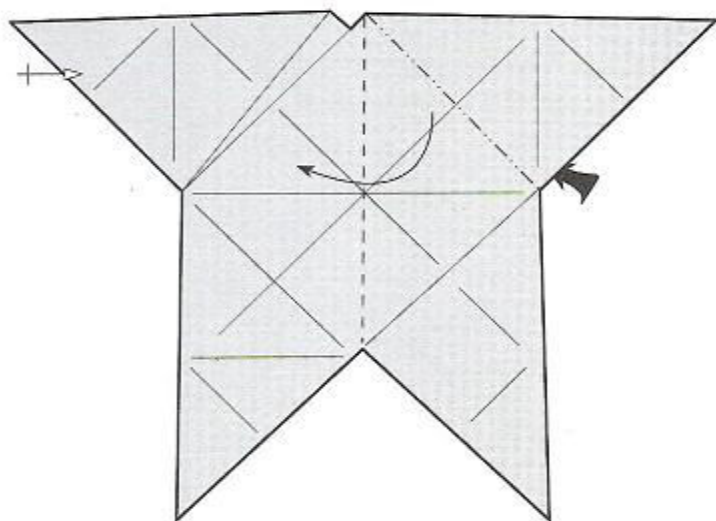

6

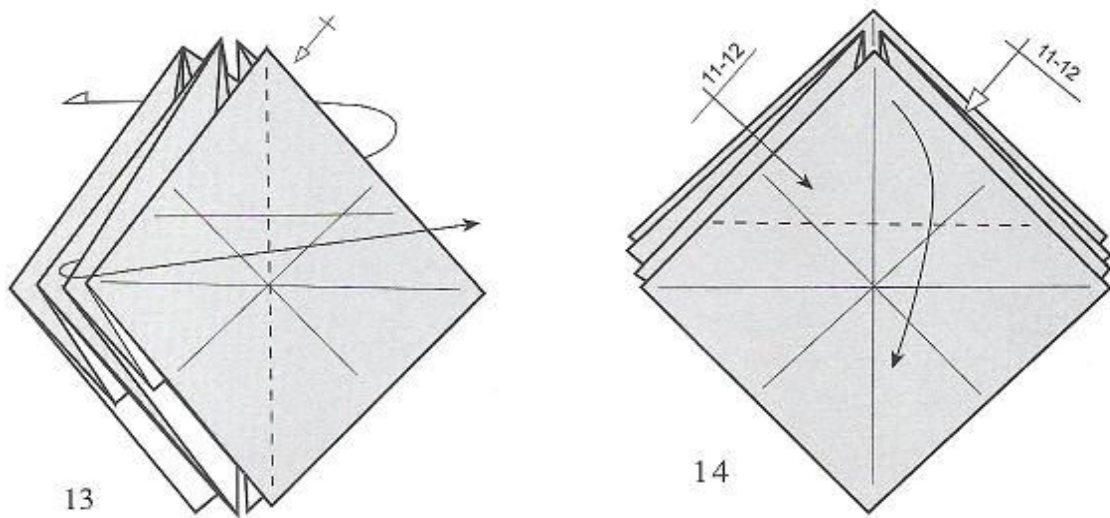
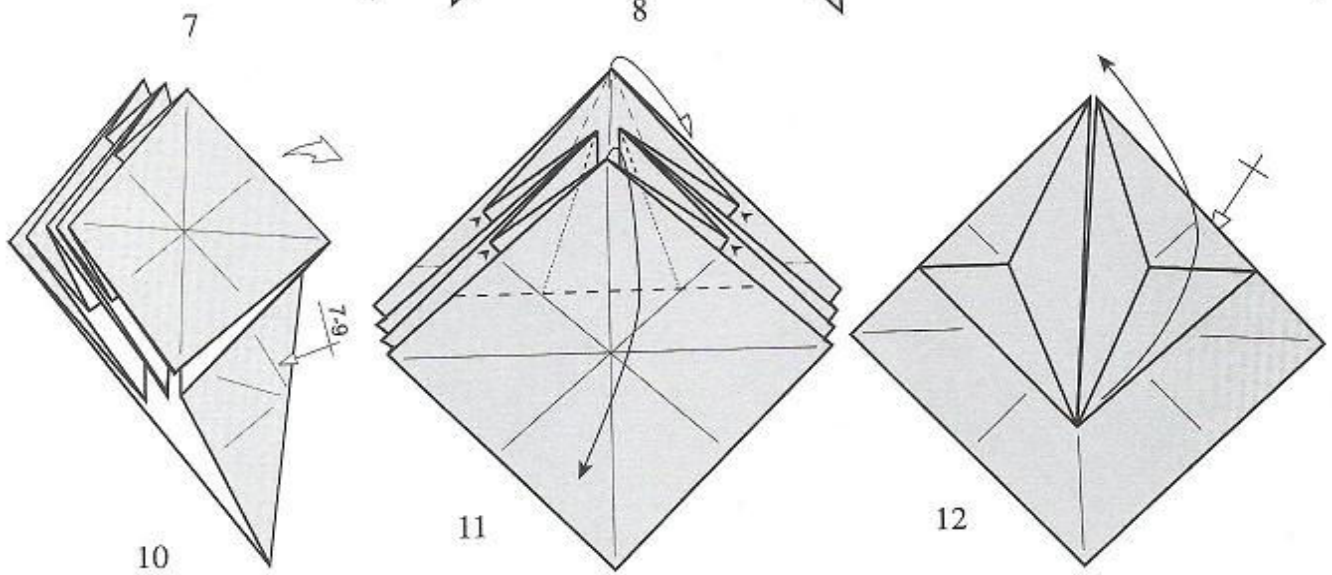
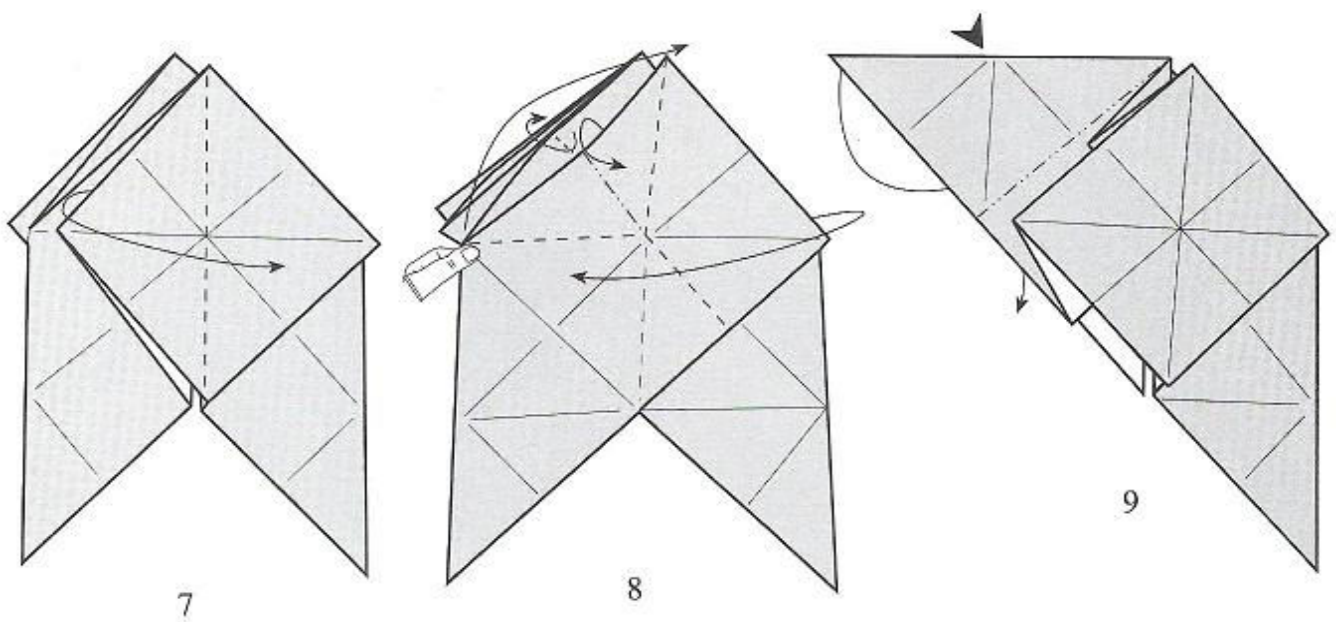

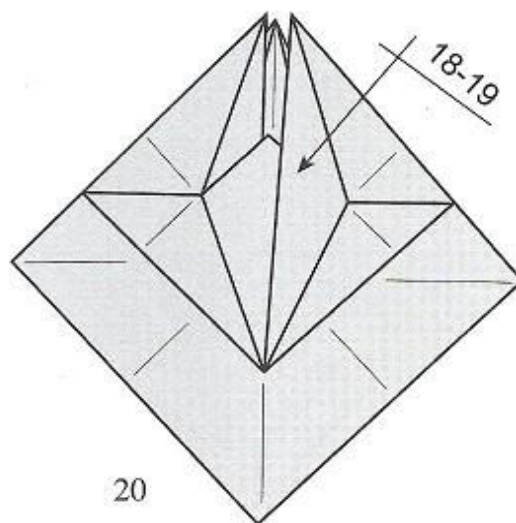
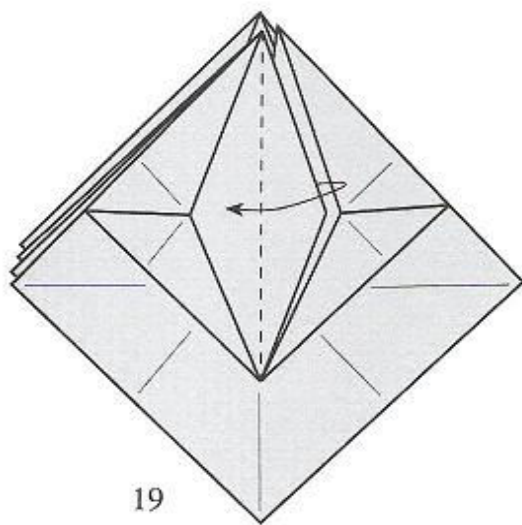
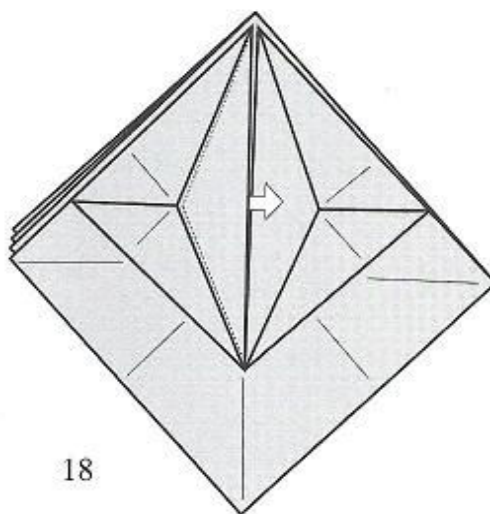
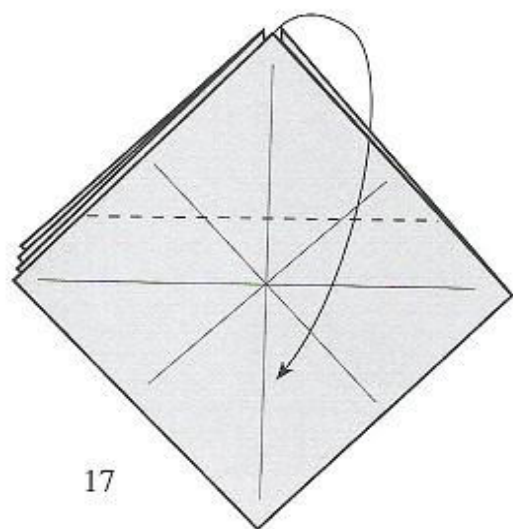
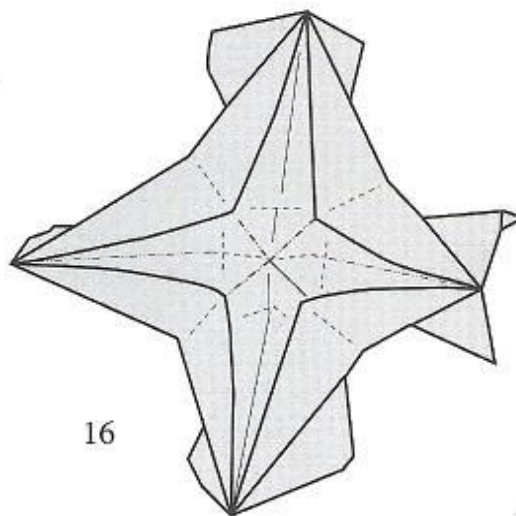
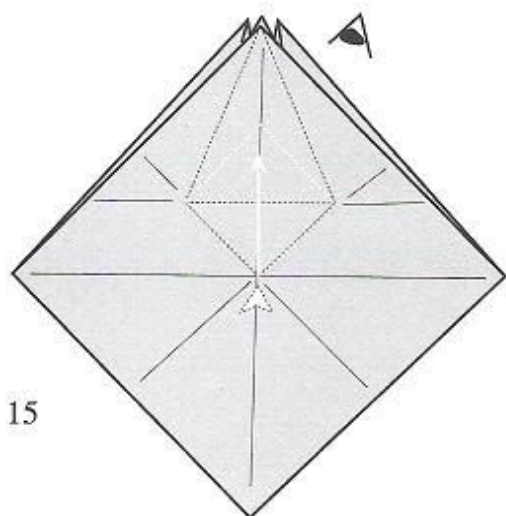

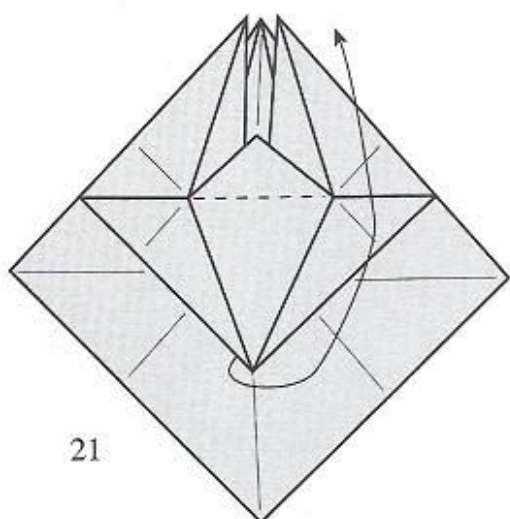

21

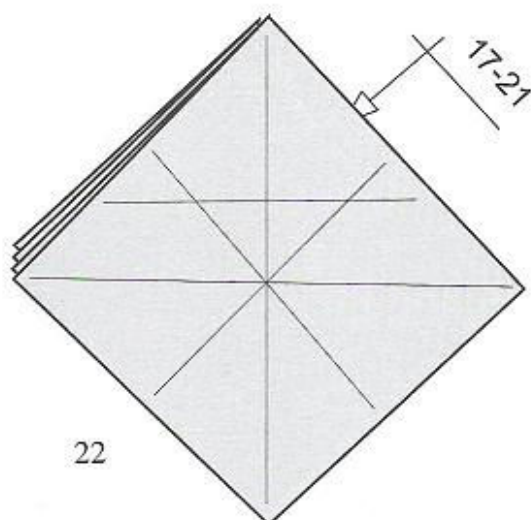

22

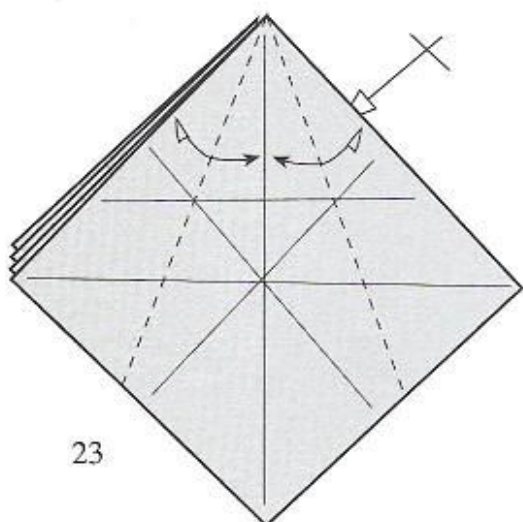

23

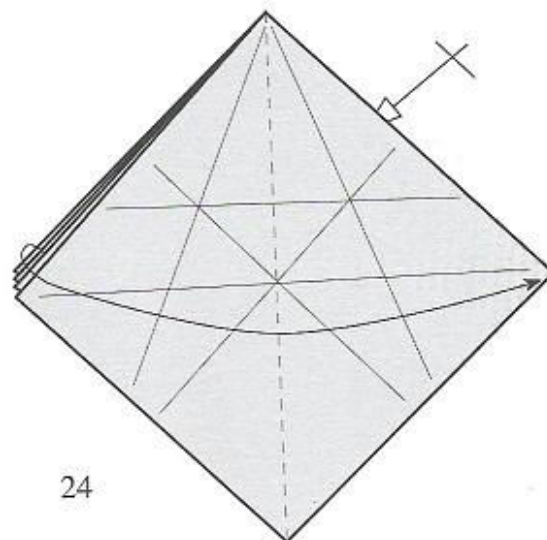

24

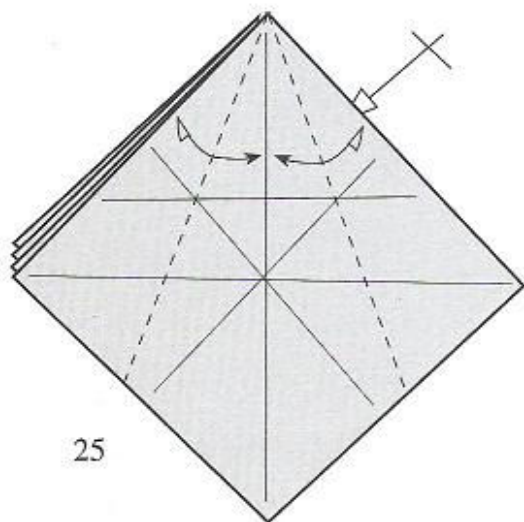

25

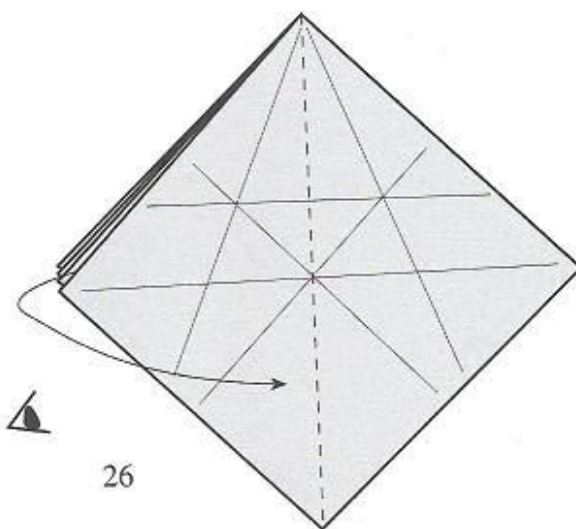

26

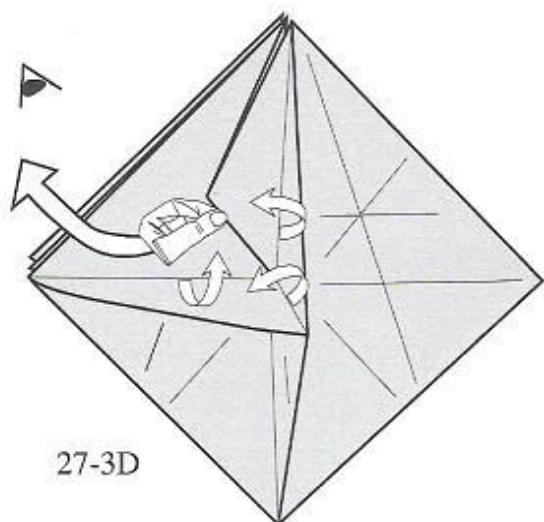

27-3D

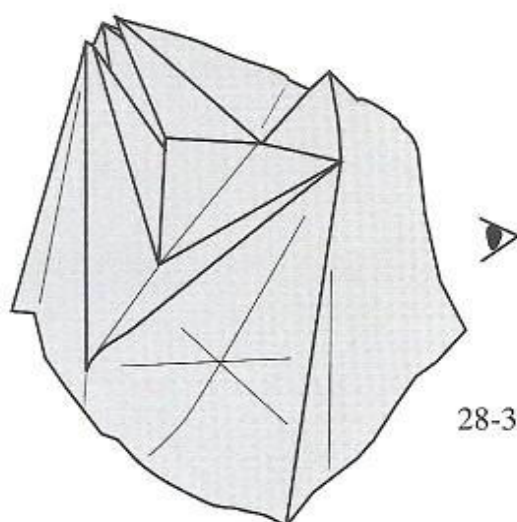

28-3D

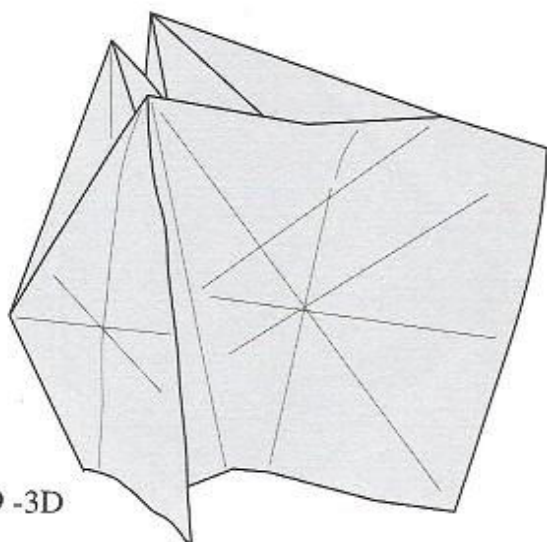

29-3D

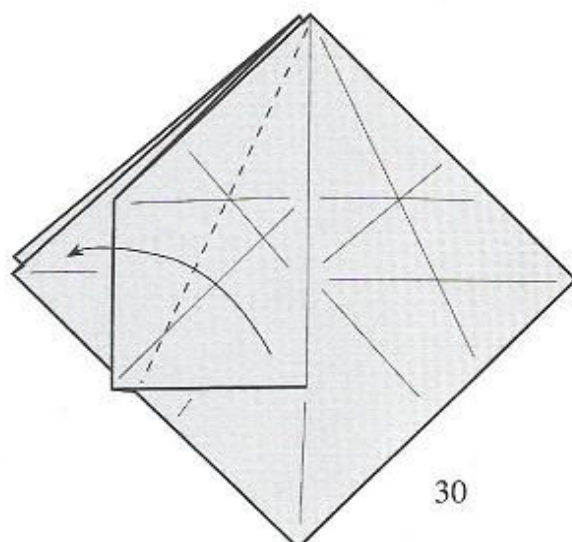

30

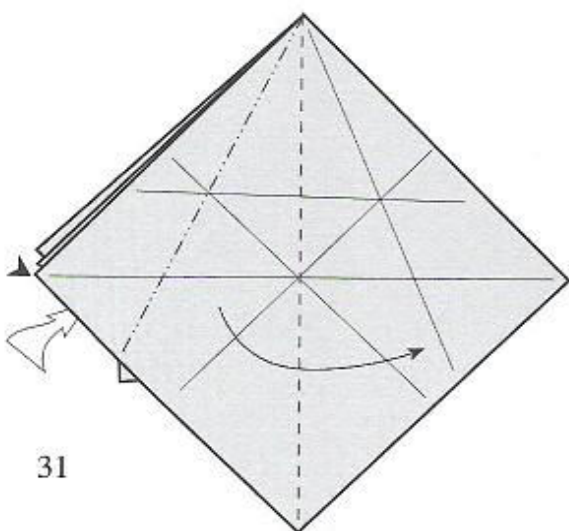

31

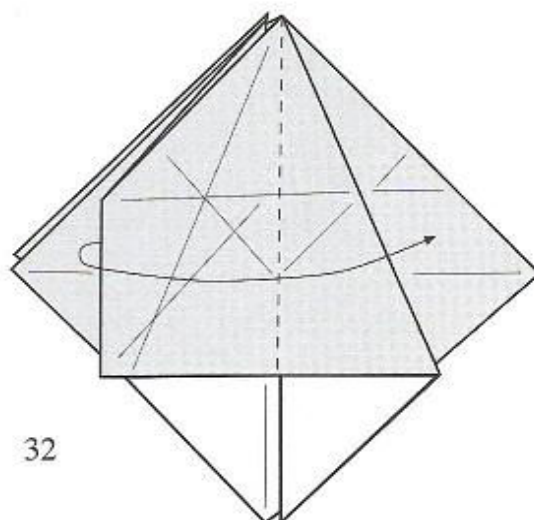

32

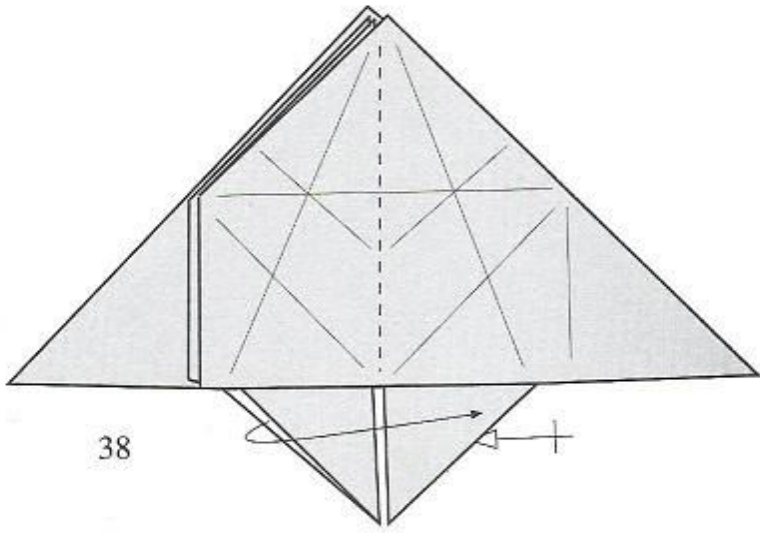
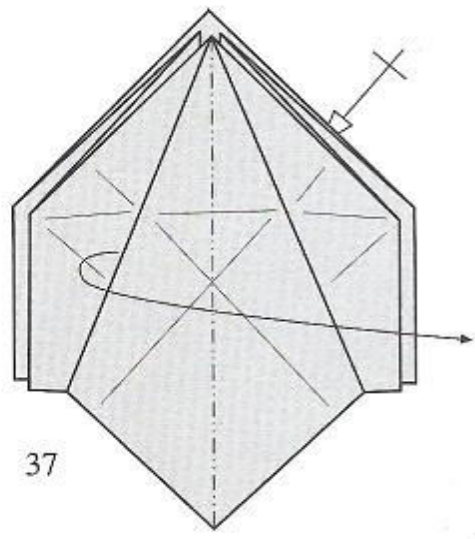
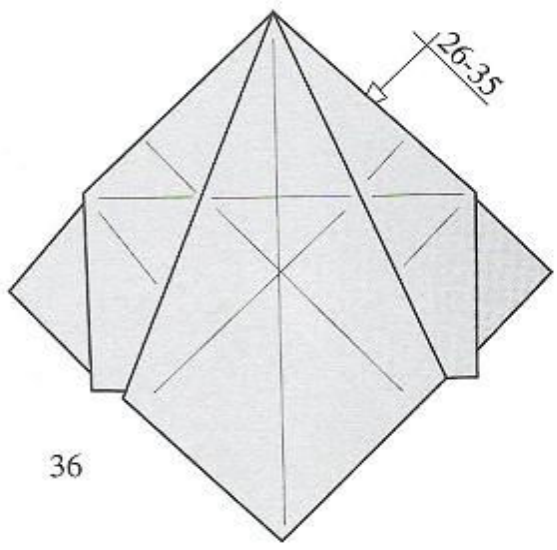
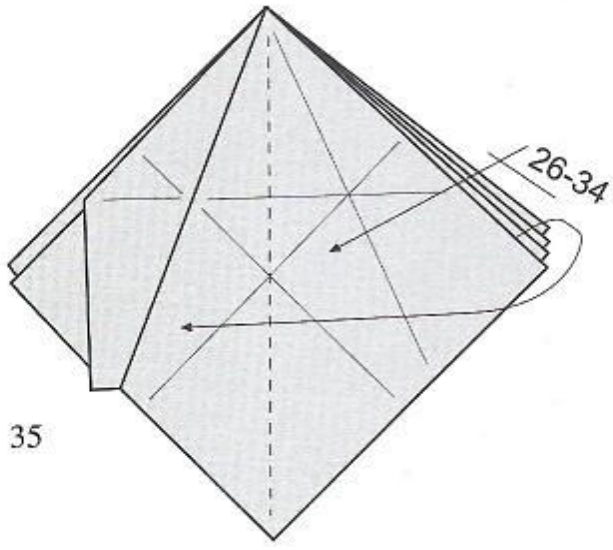
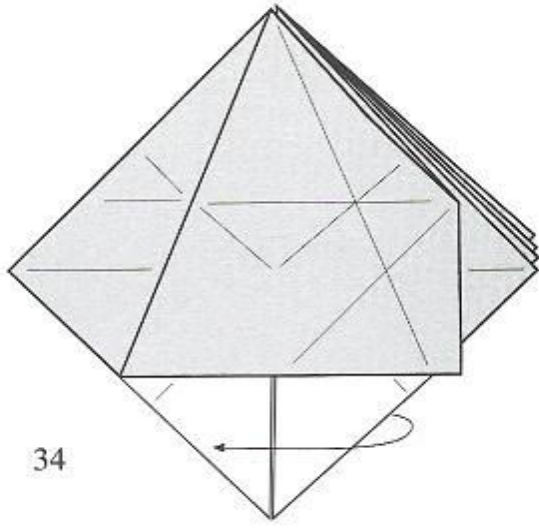
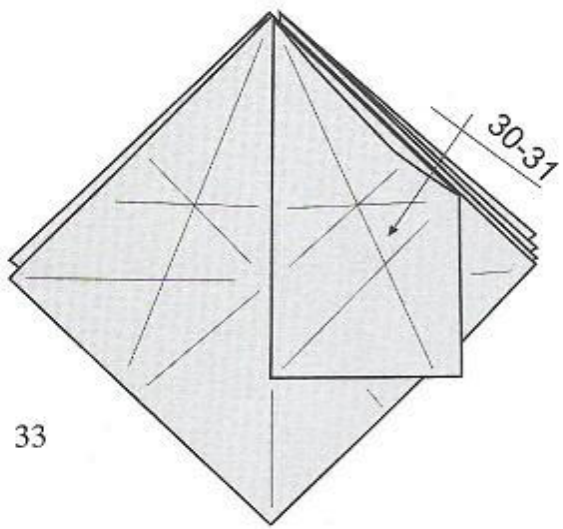

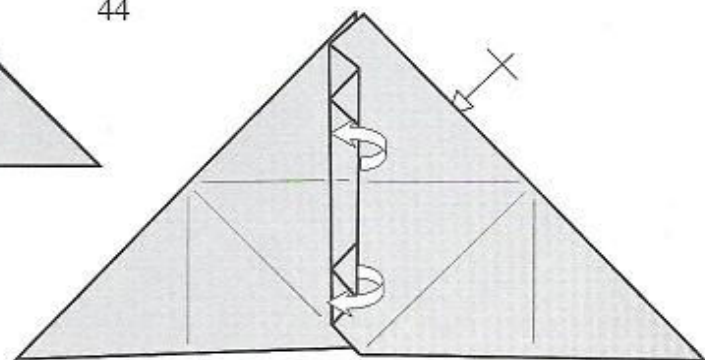
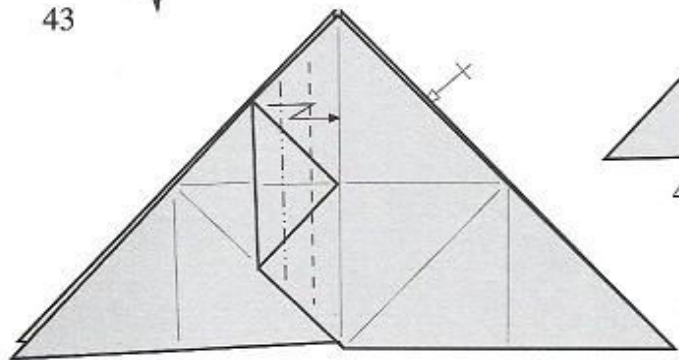
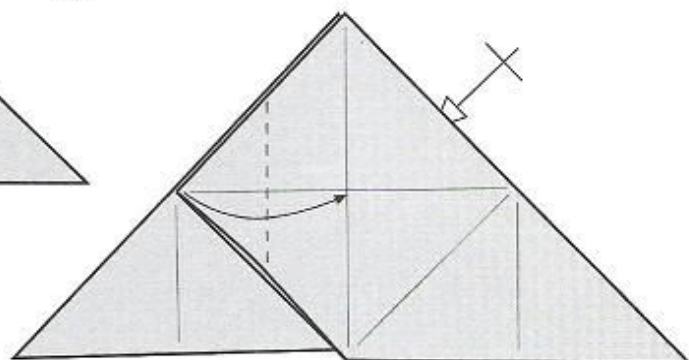
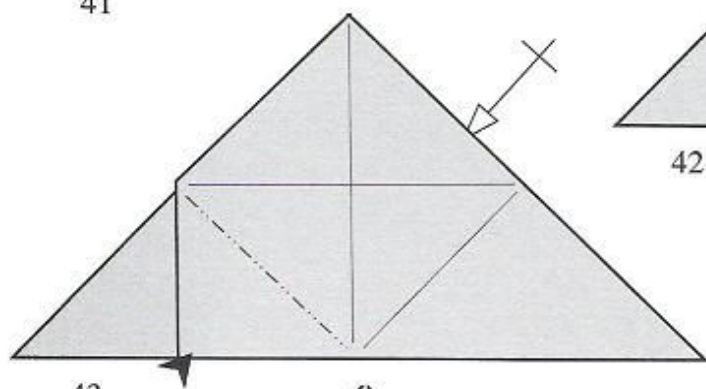
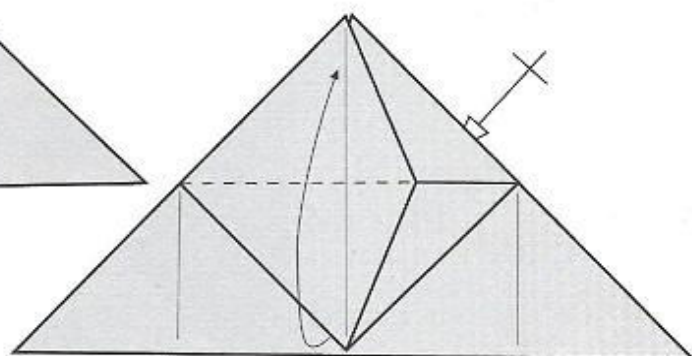
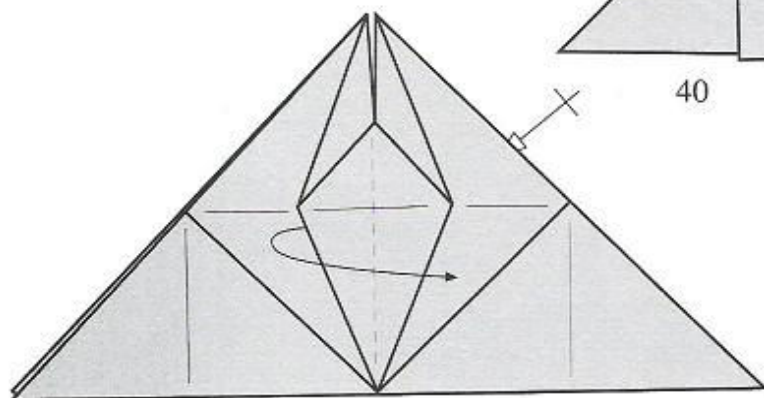
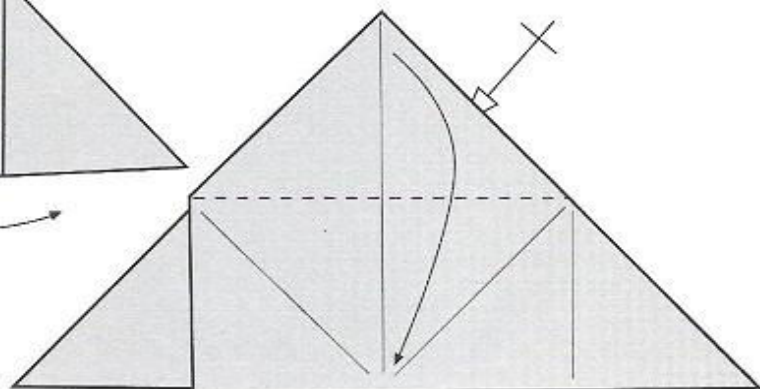
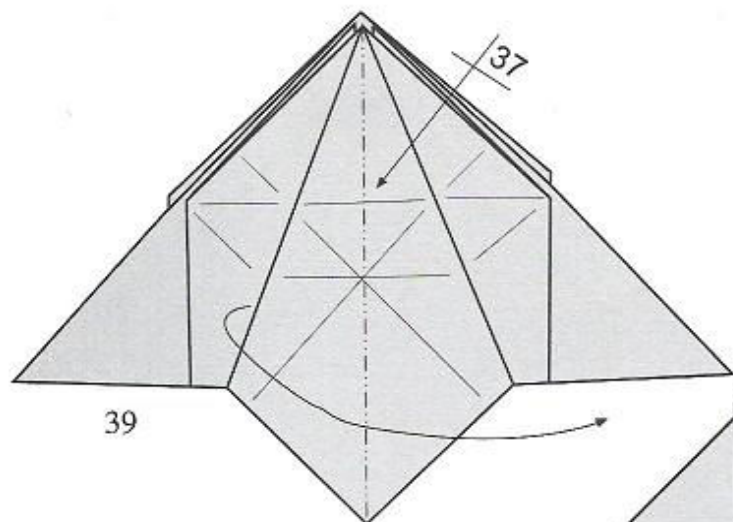

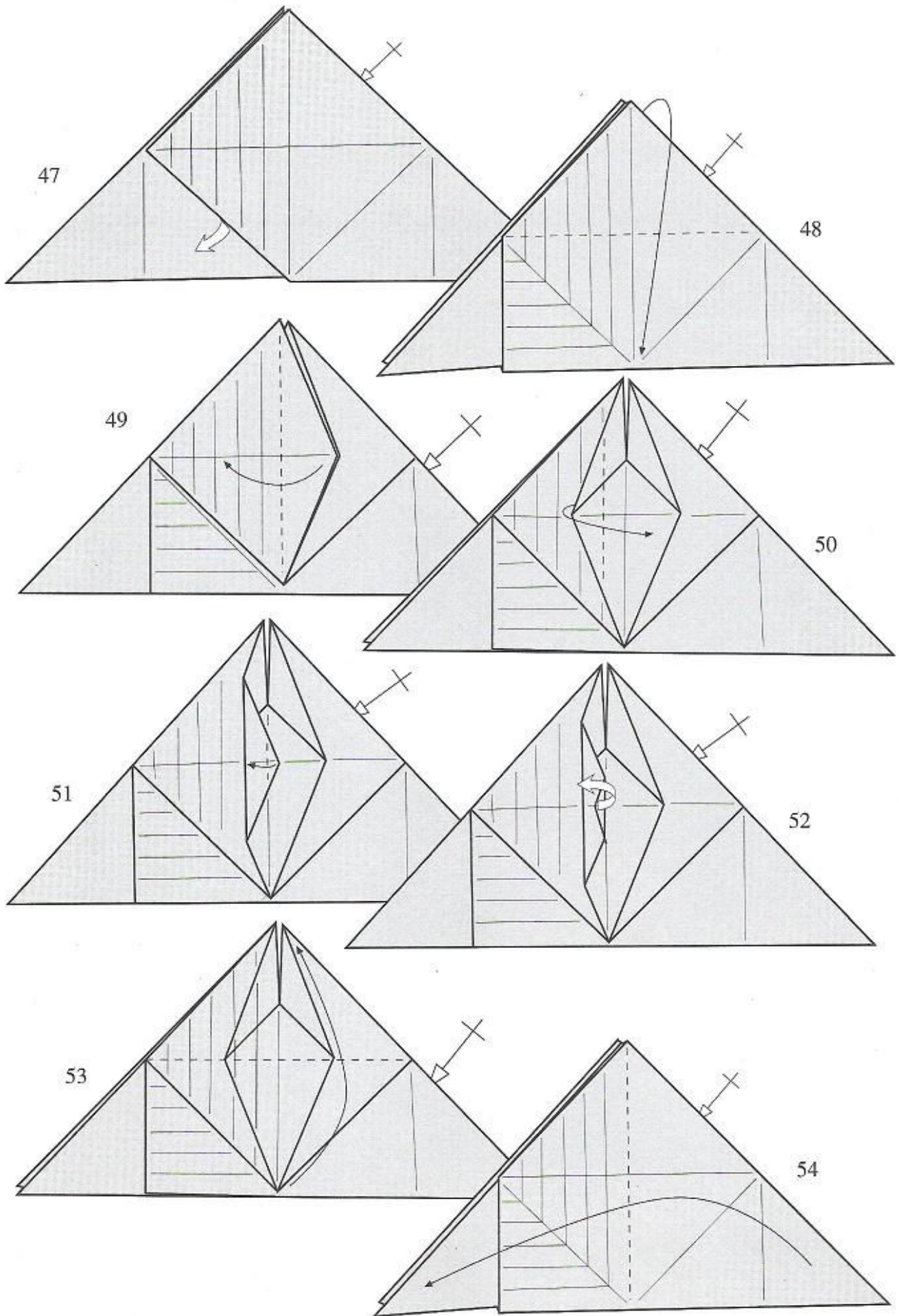

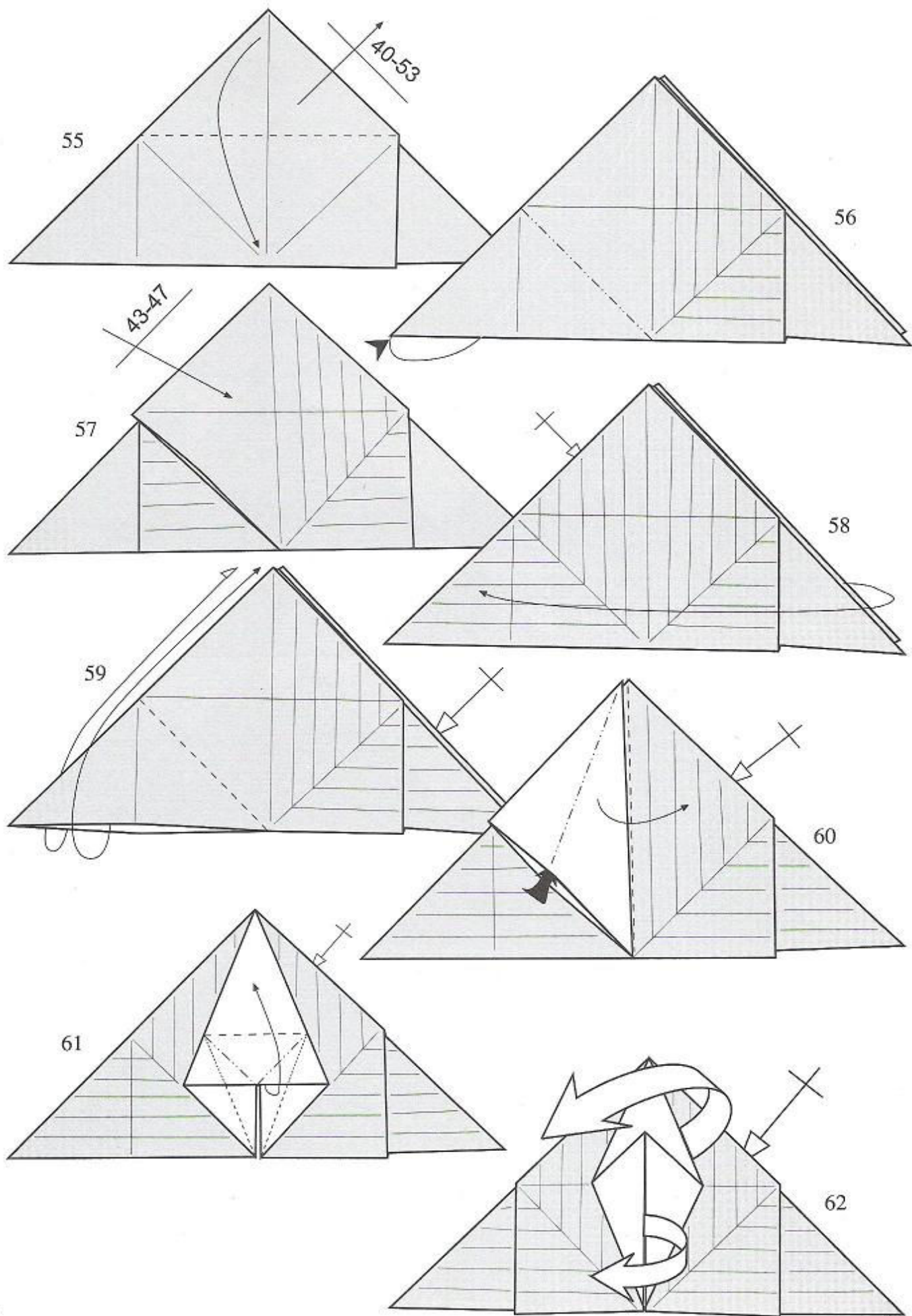

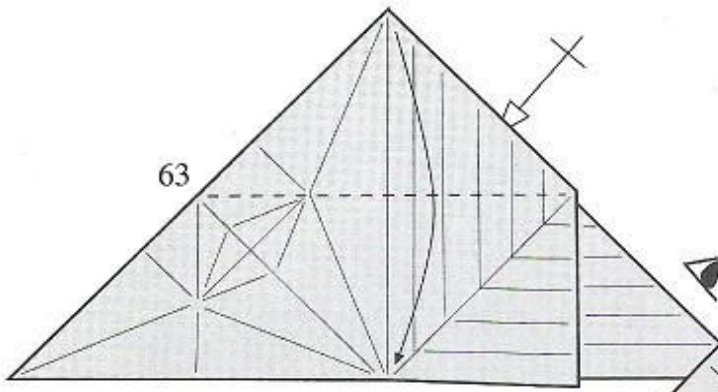

63

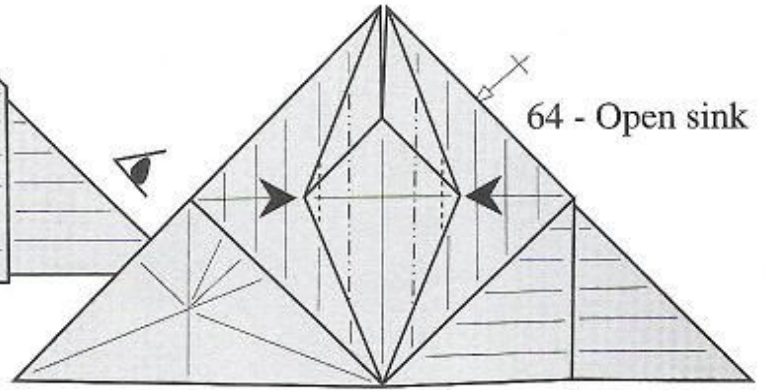

64 - Open sink

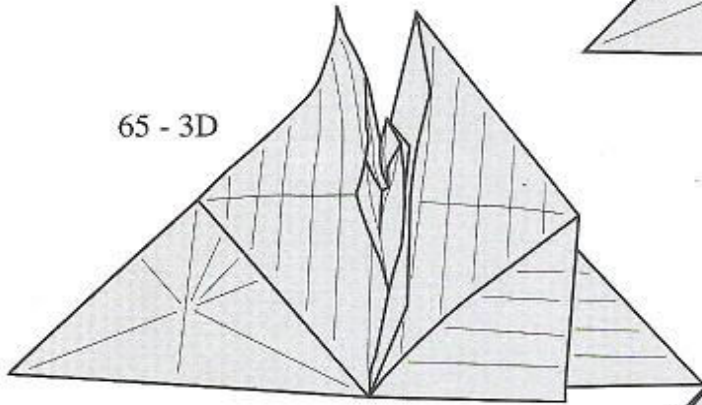

65 - 3D

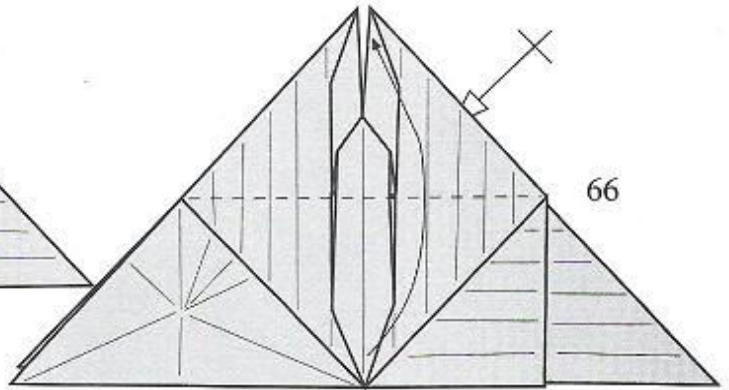

66

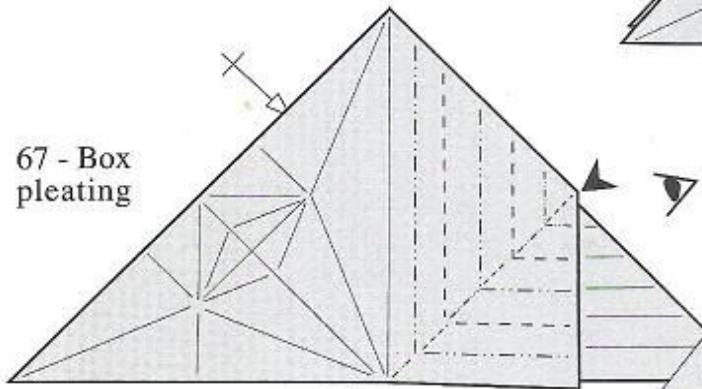

67 - Box pleating

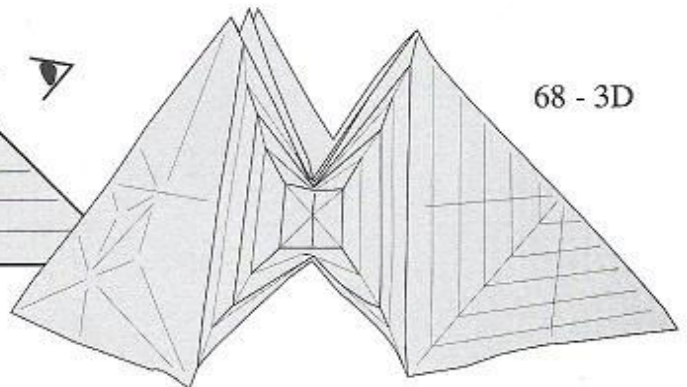

68 - 3D

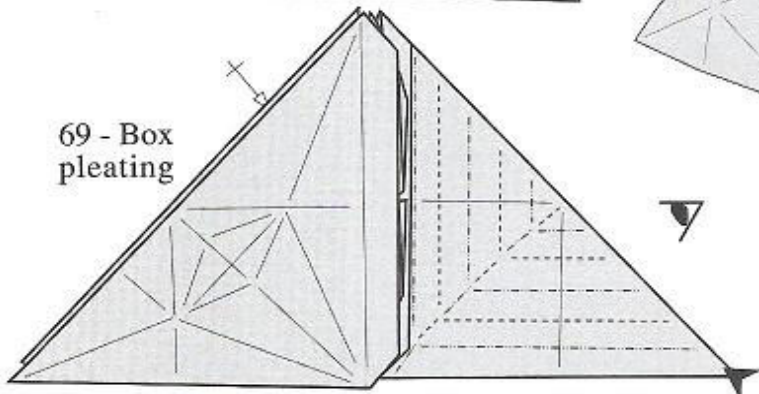

69 - Box pleating

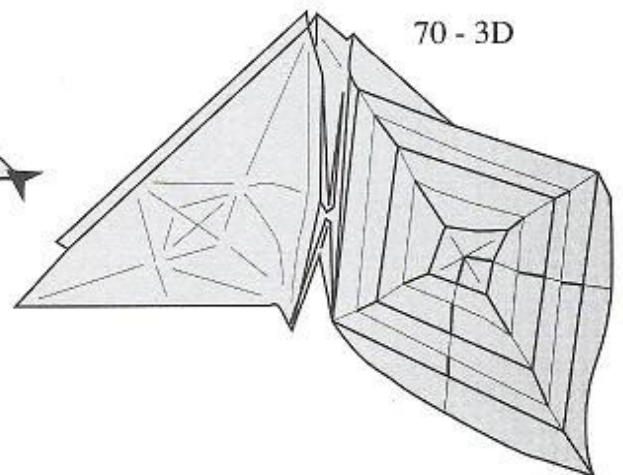

70 - 3D

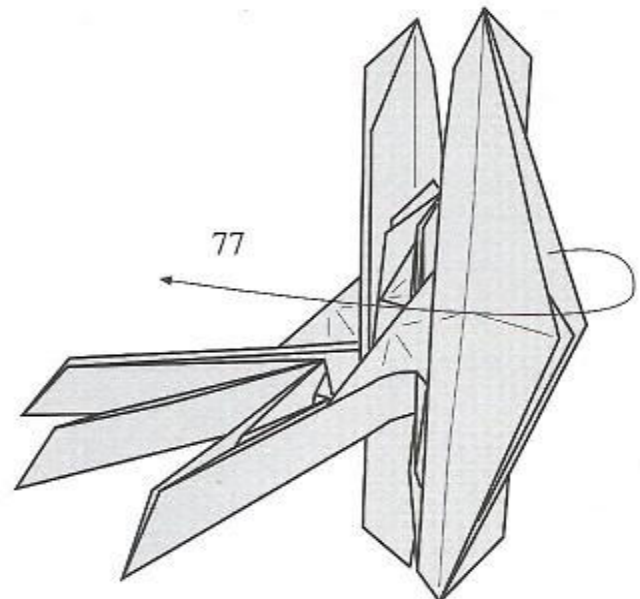
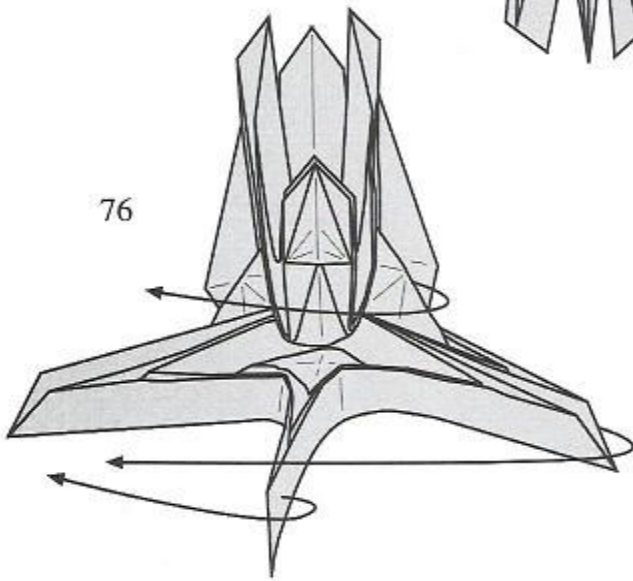
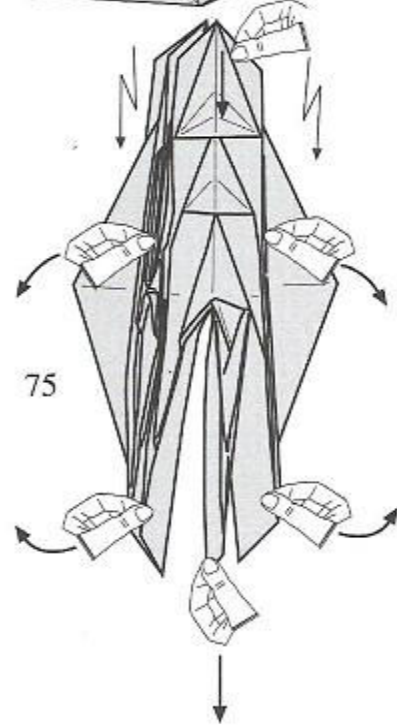
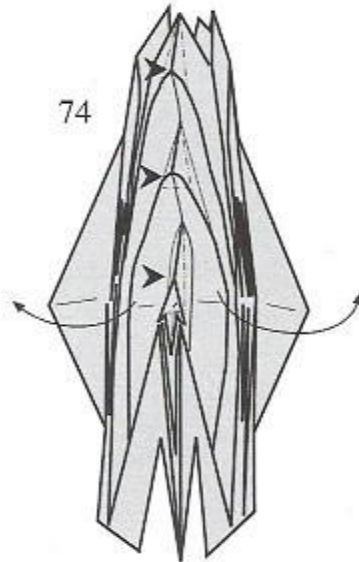
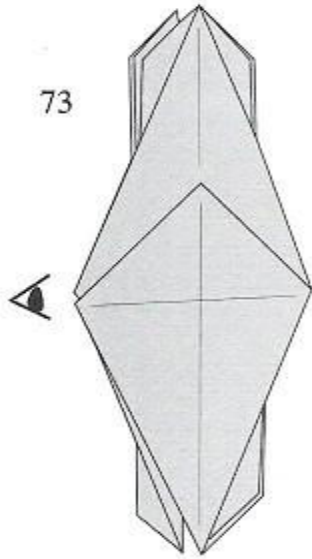
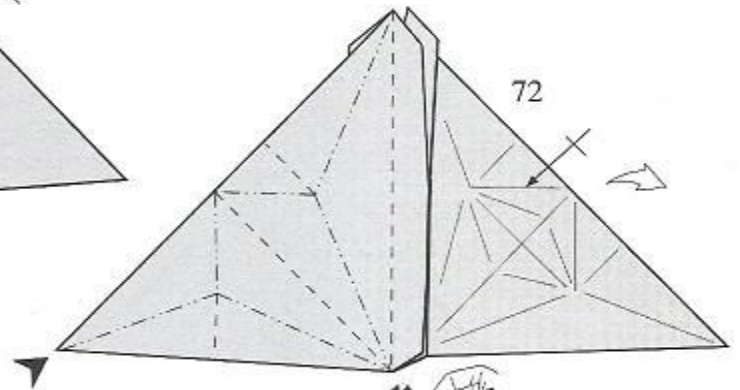
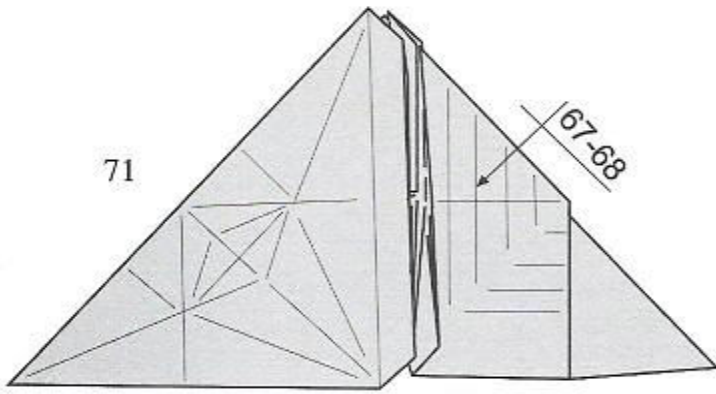

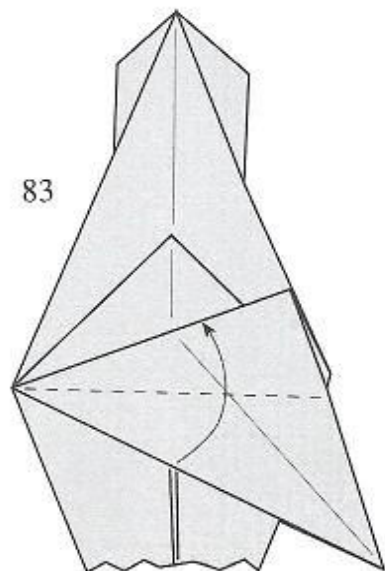
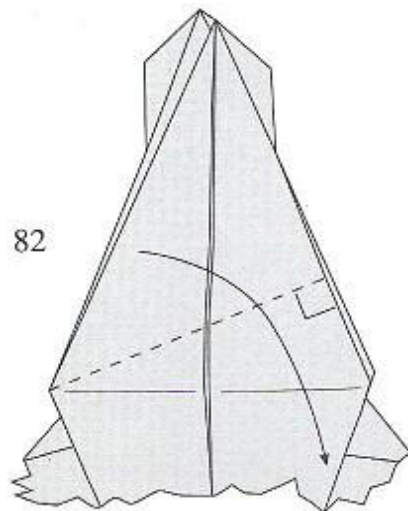
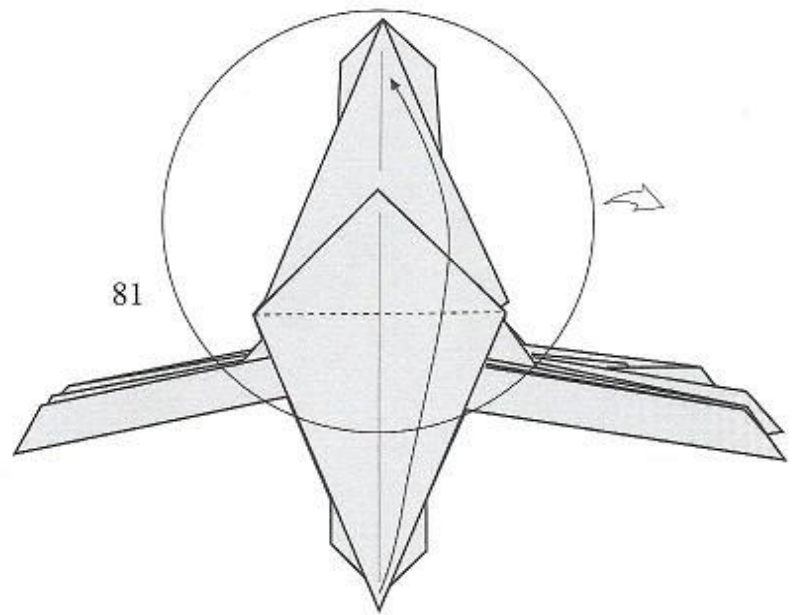
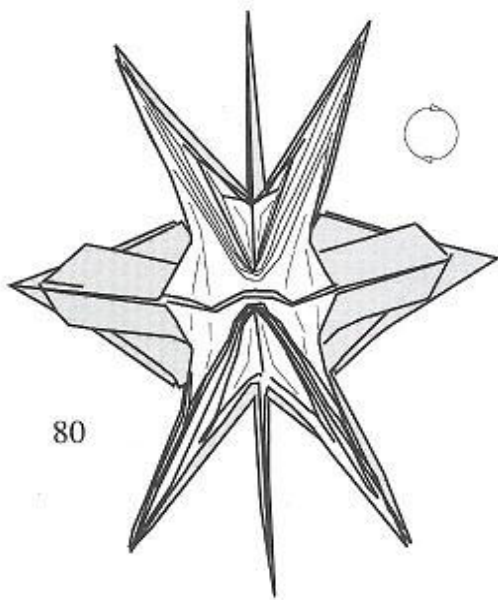
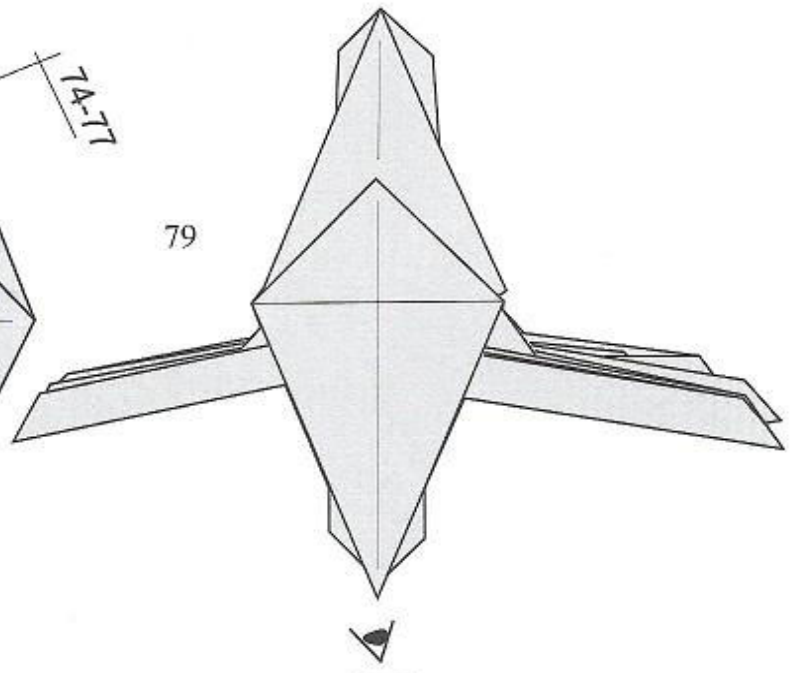
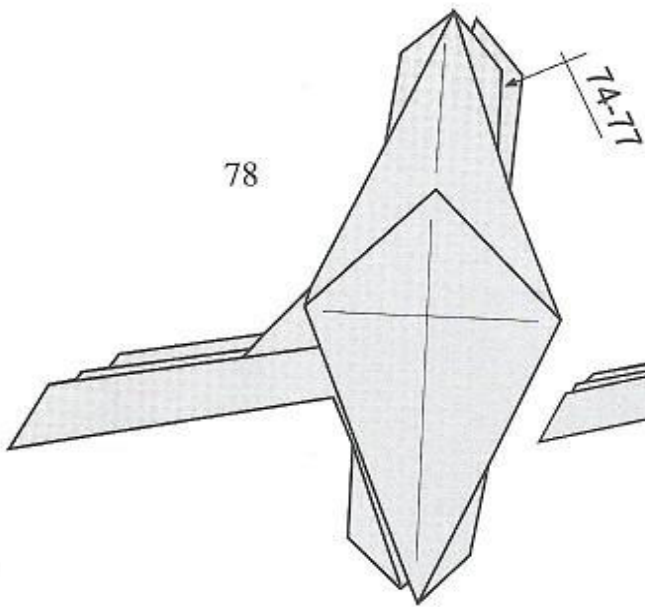

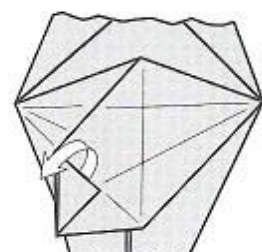
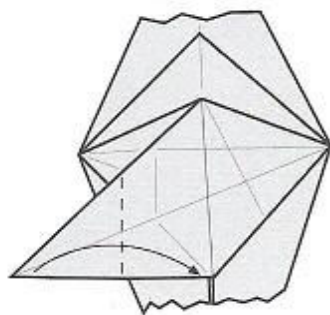
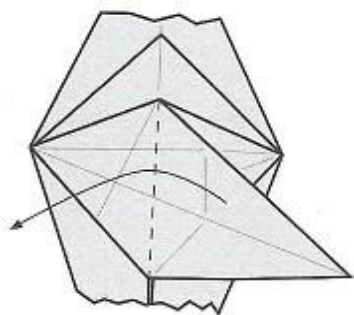
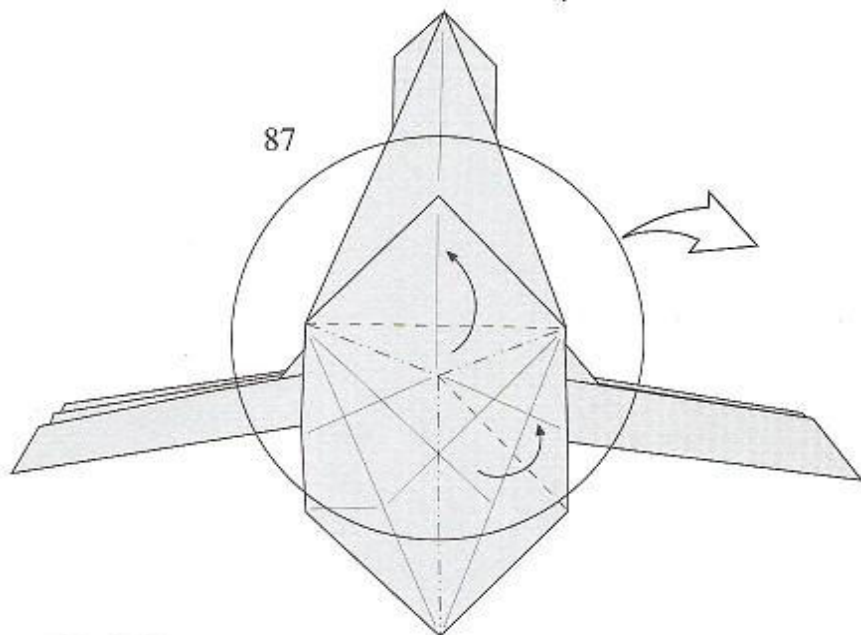
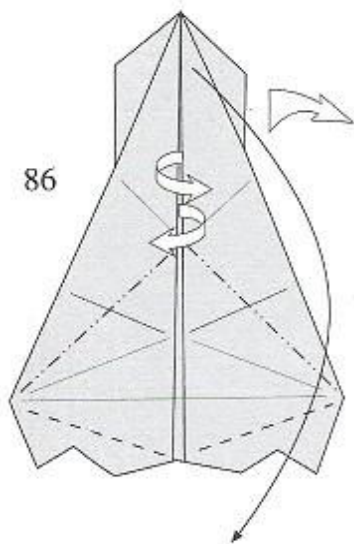
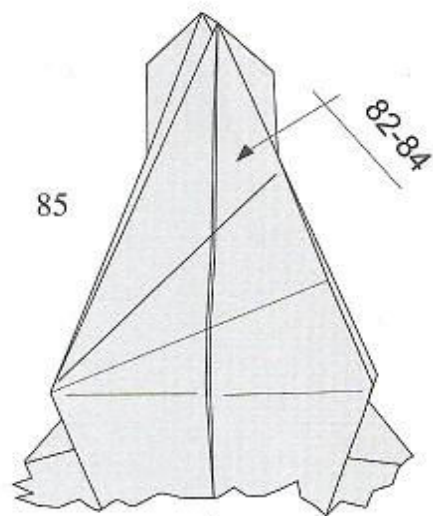
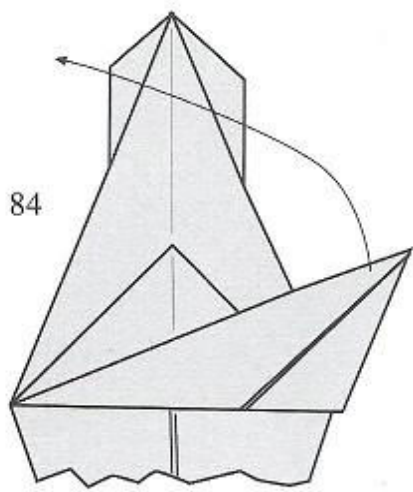

88

89

90

91

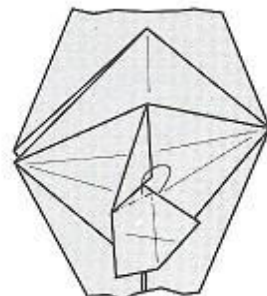
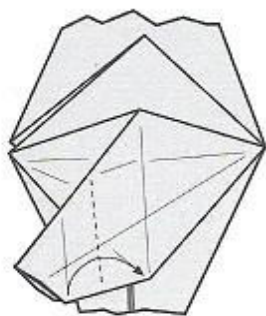
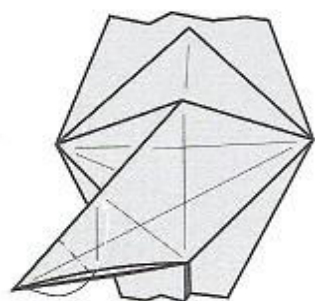

92

93

94

95

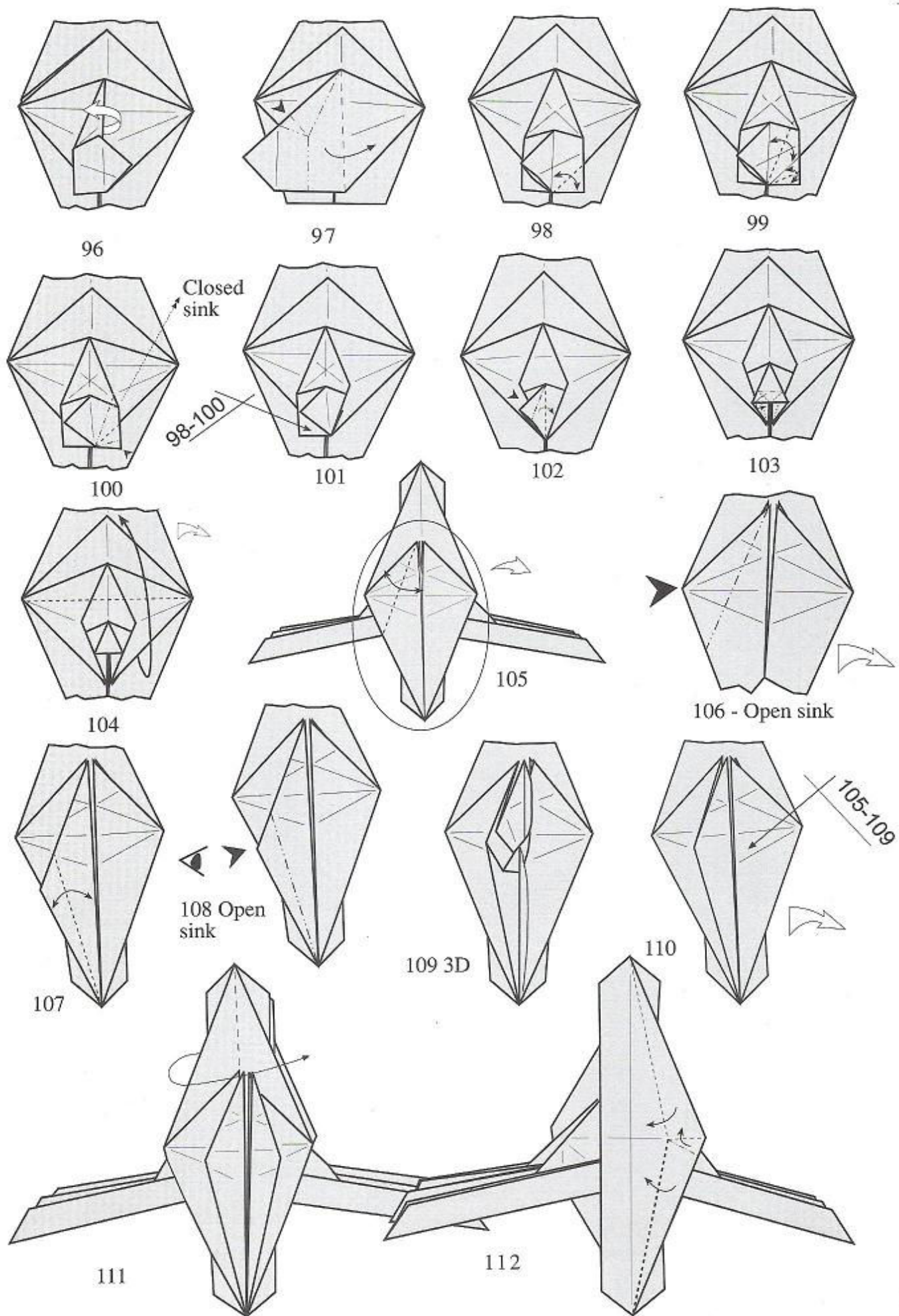

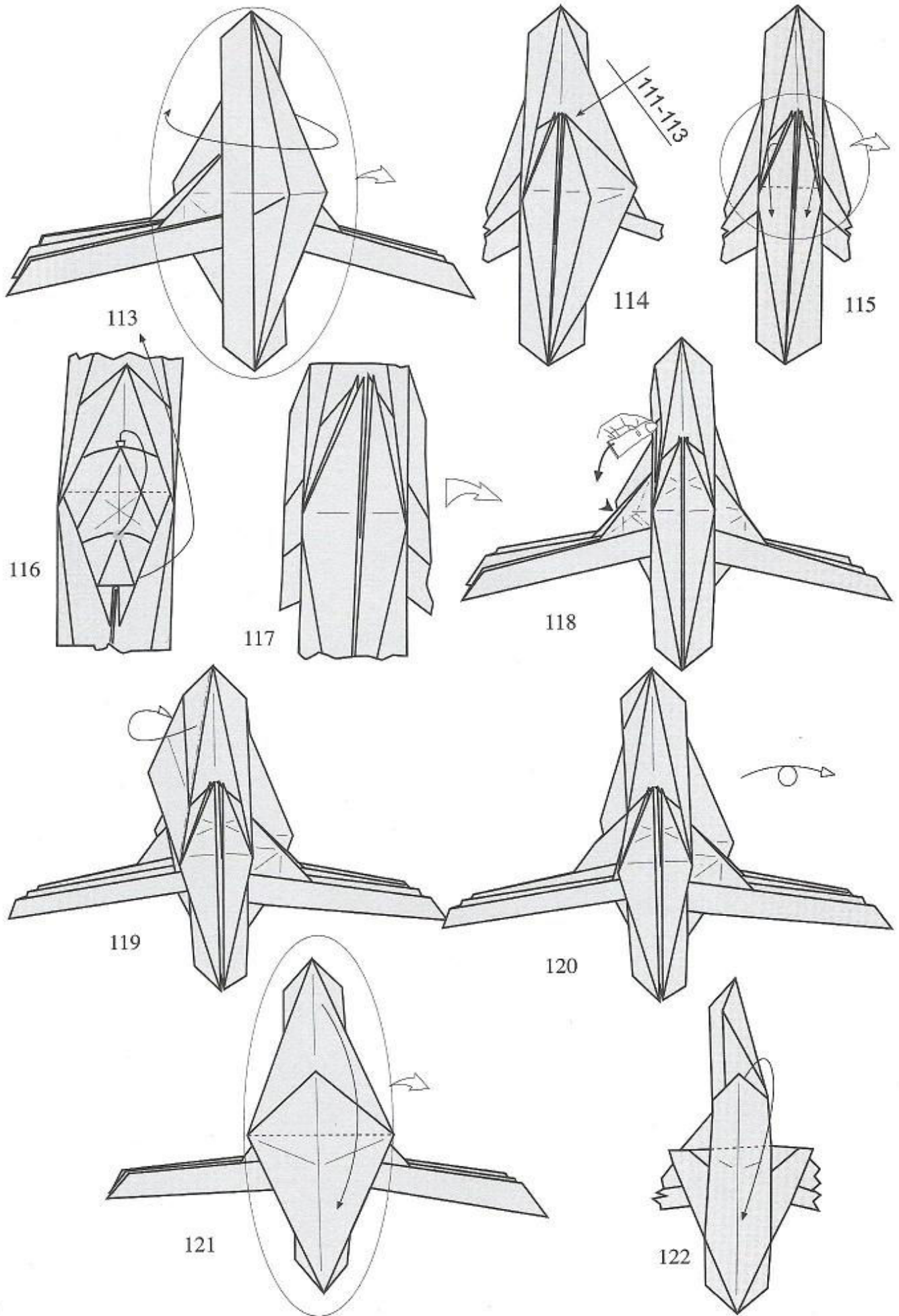

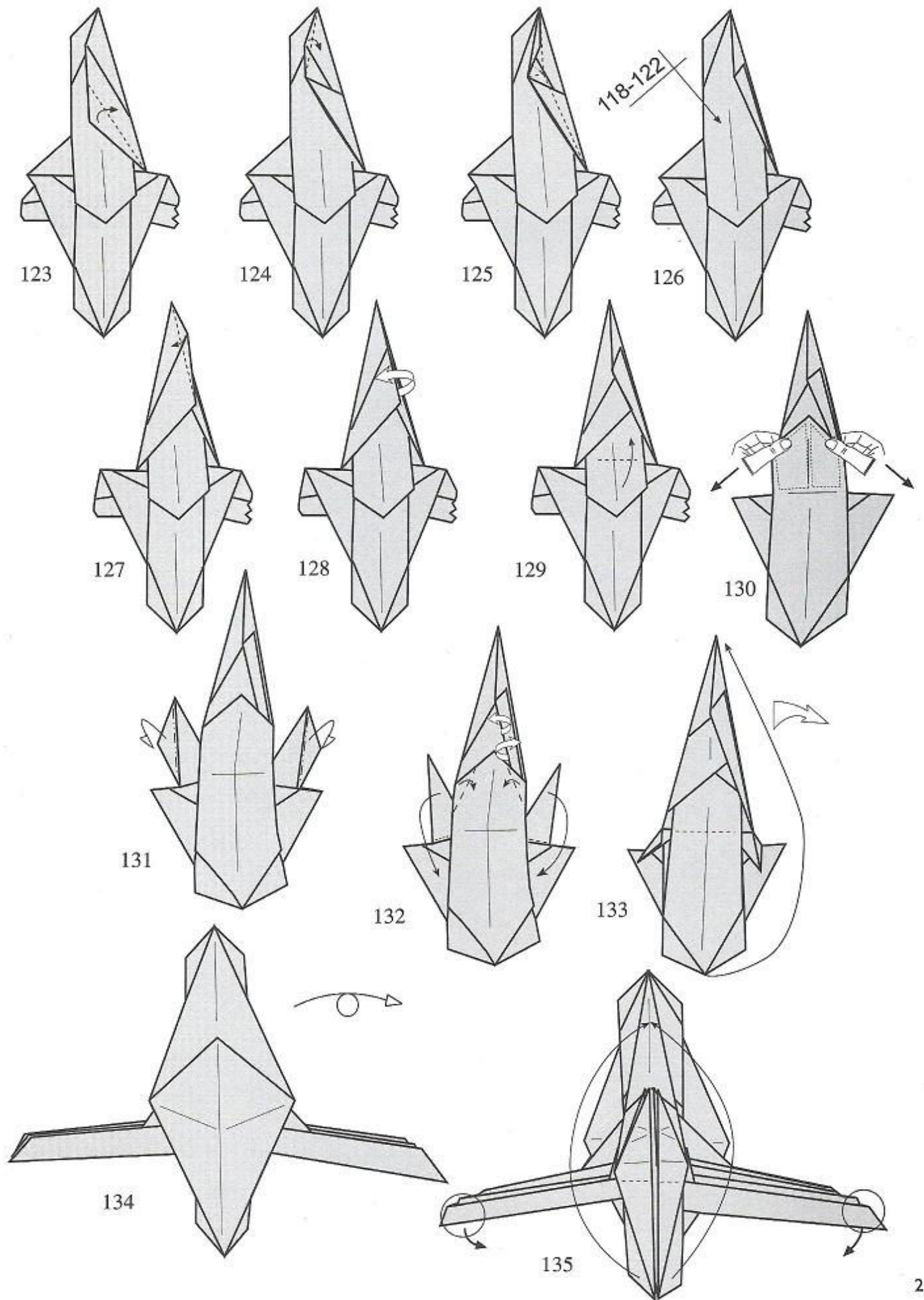

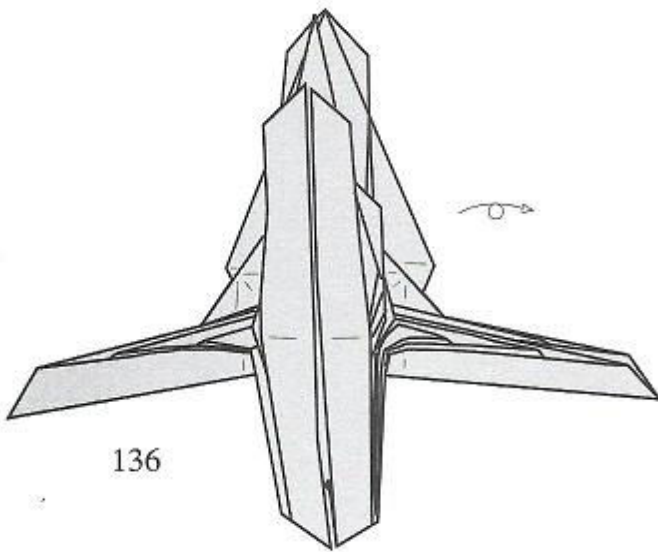

136

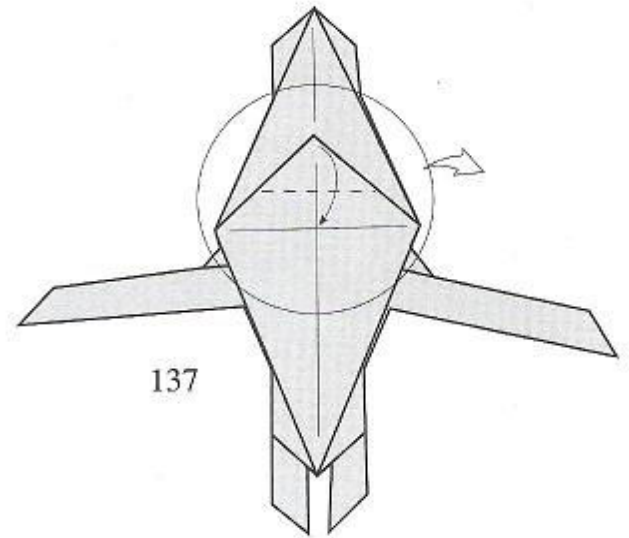

137

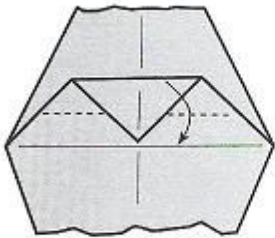

138

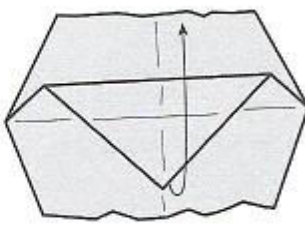

139

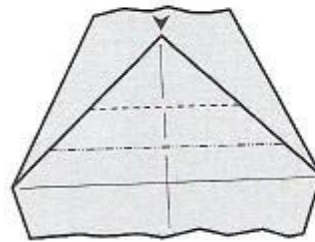

140 Open sink

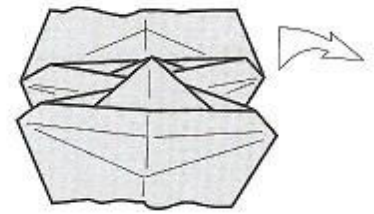

141

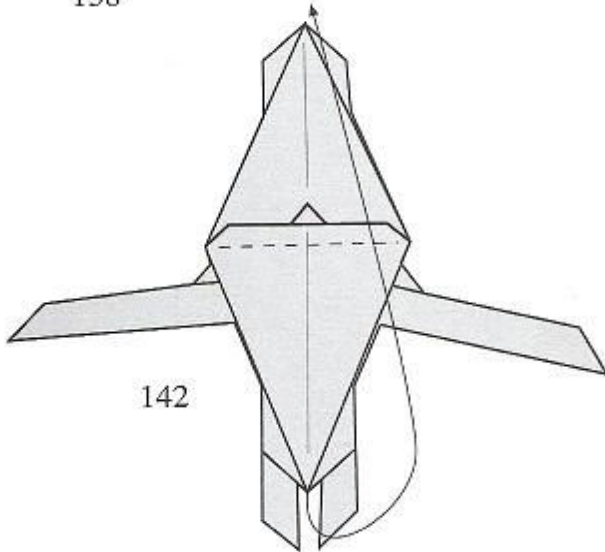

142

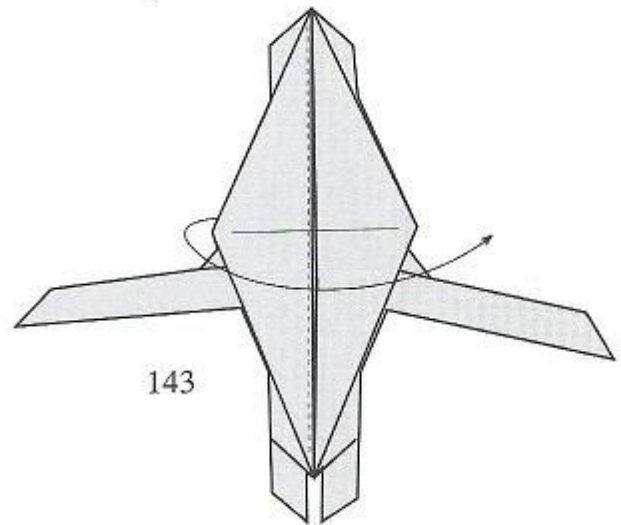

143

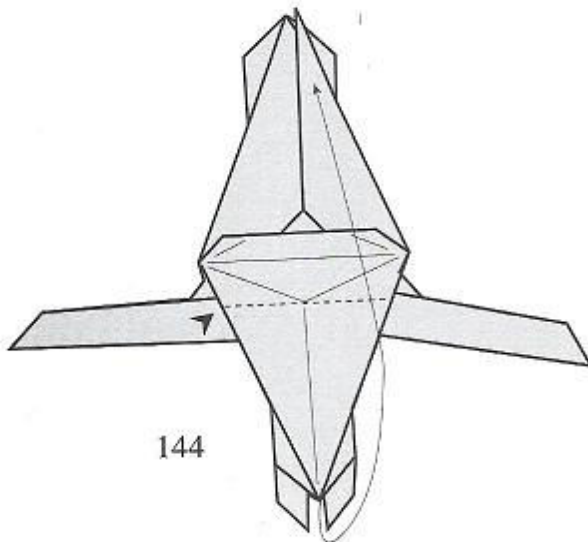

144

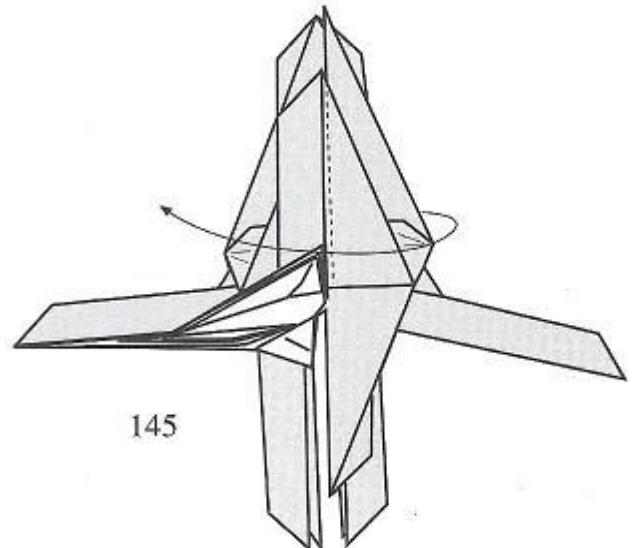

145

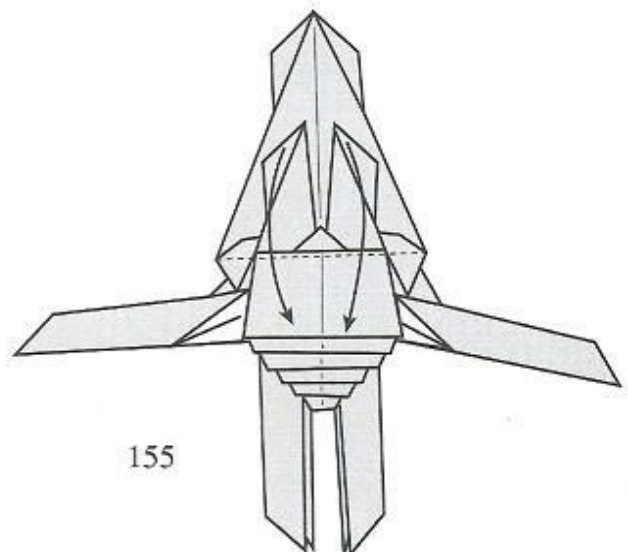
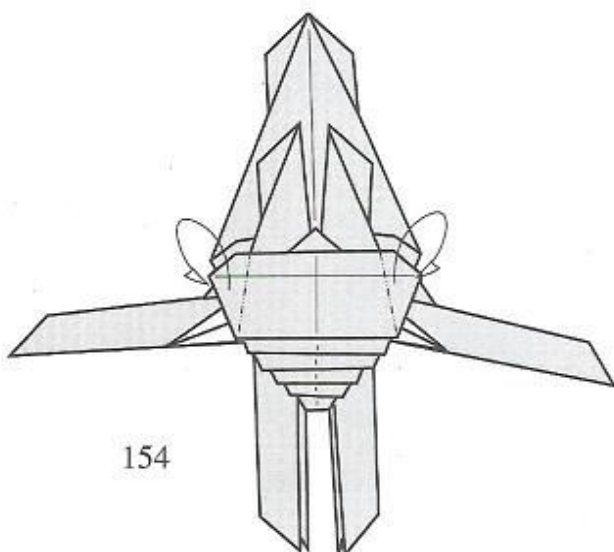
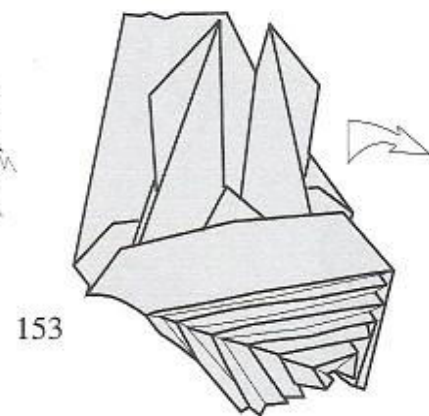
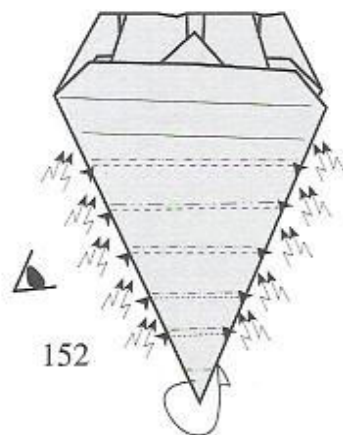
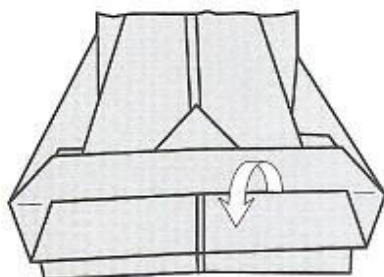
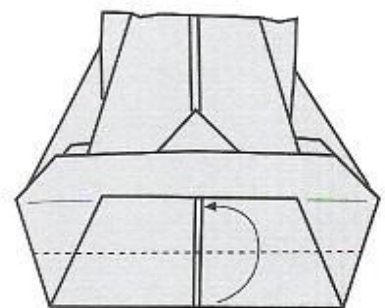
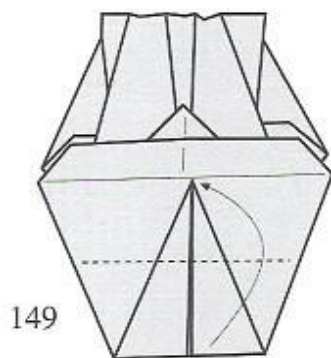
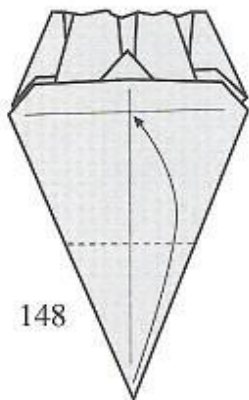
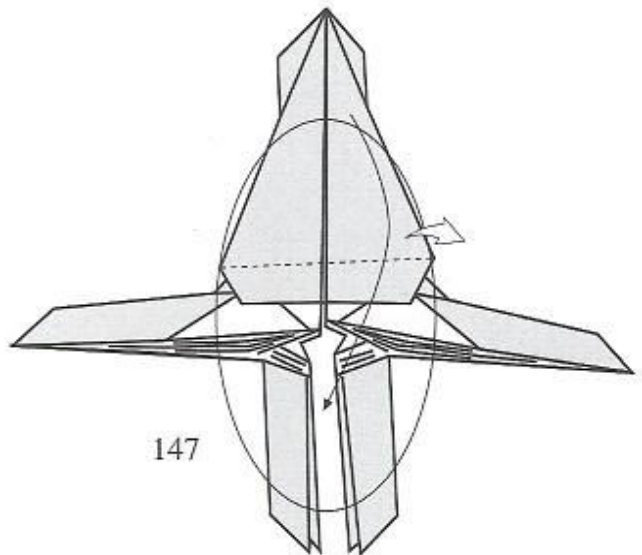
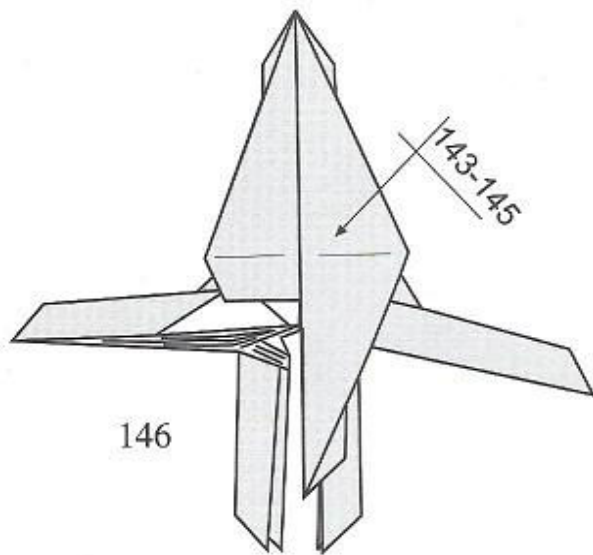

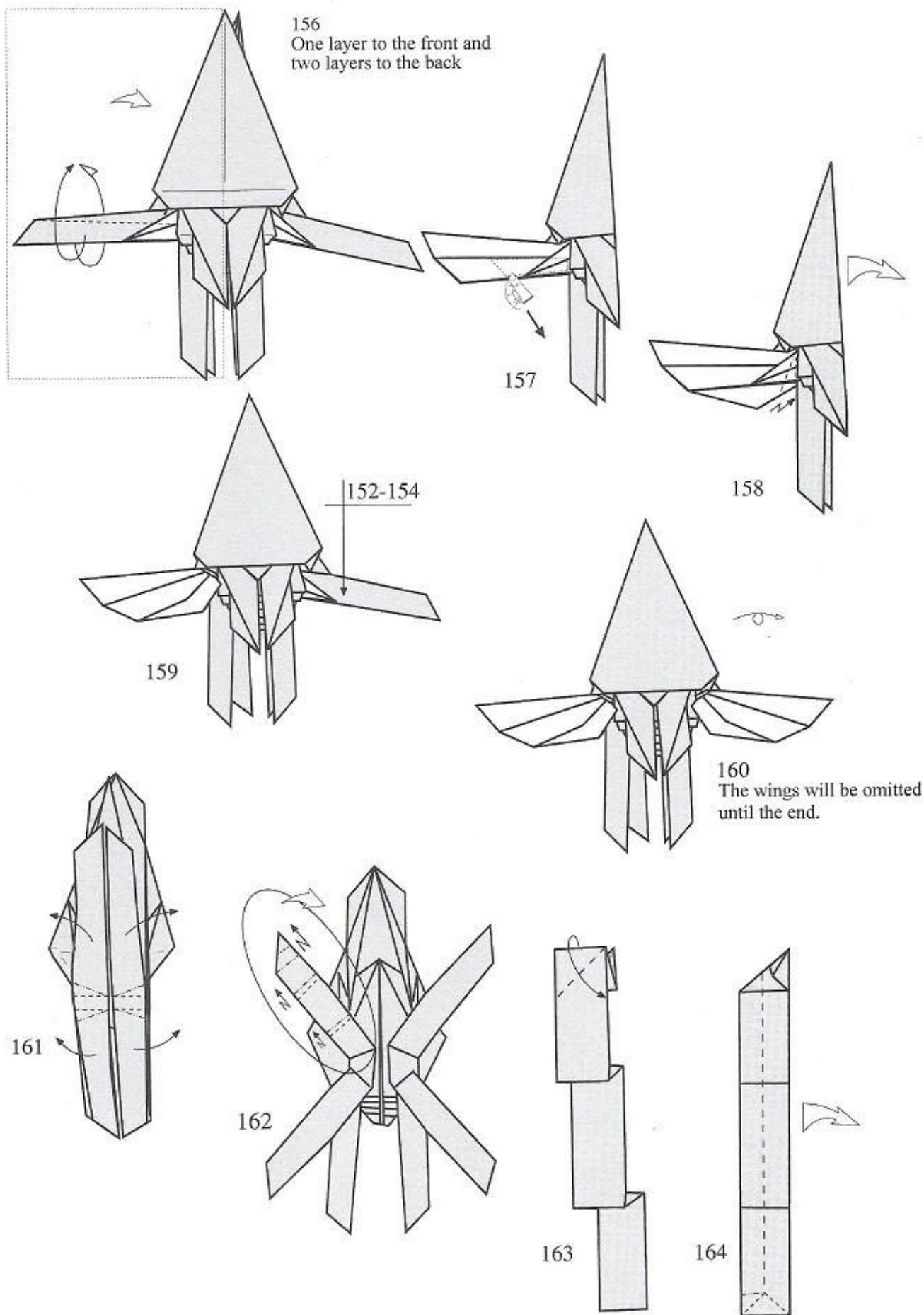

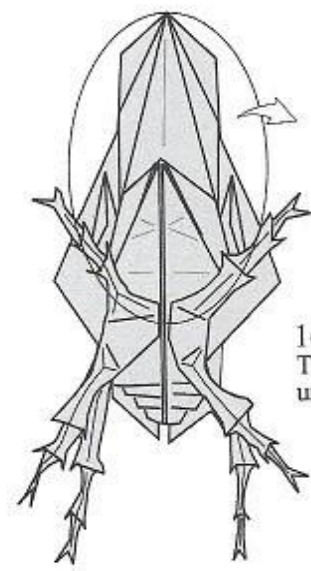
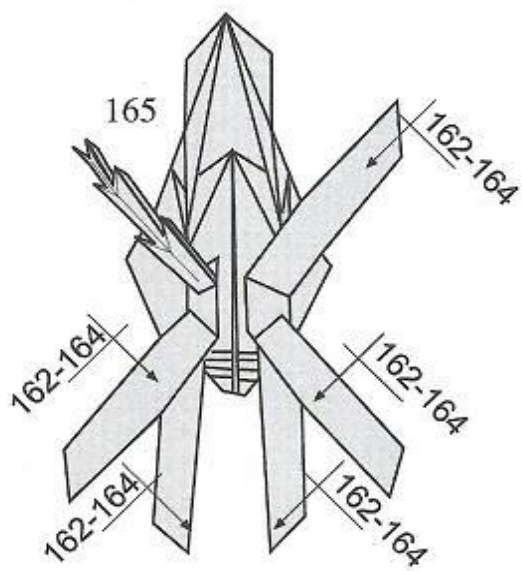

166
The legs will be omitted until the end.

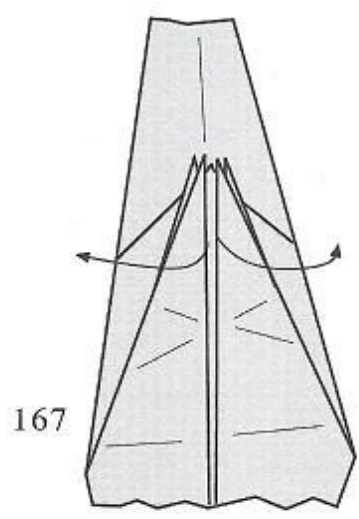

167

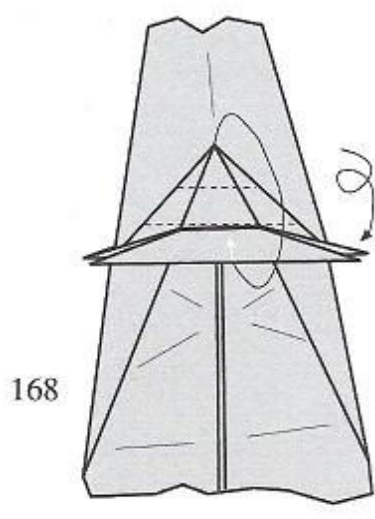

168

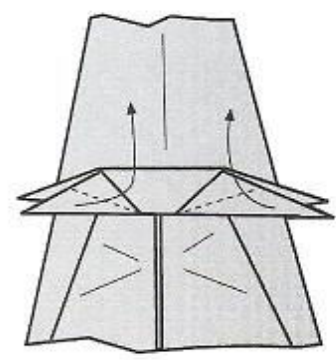

169

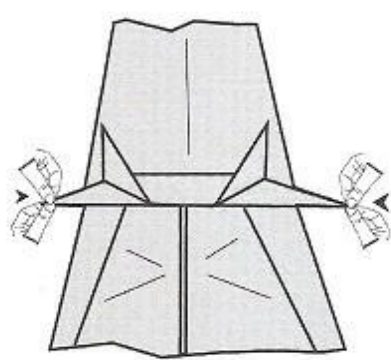

170

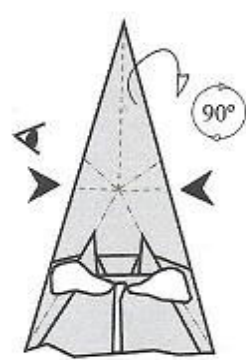

171

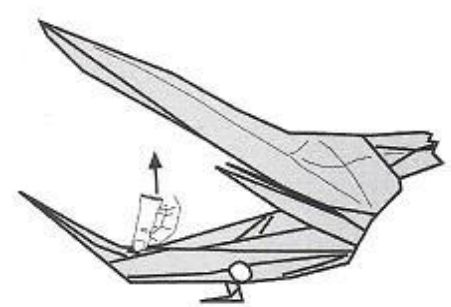

172

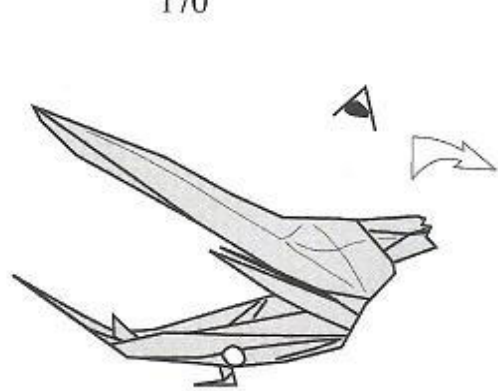

173

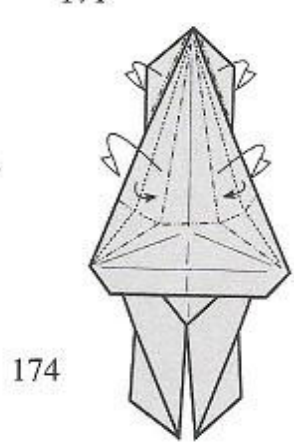

174

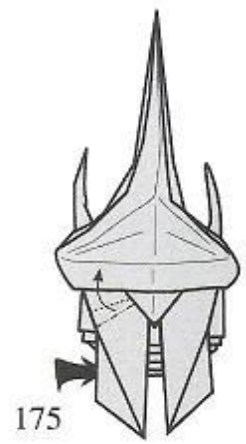

175

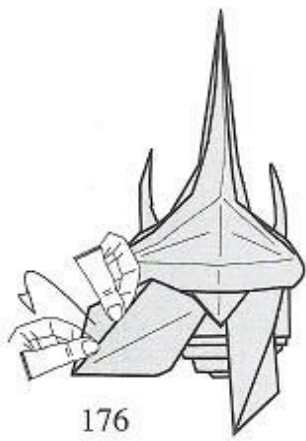

176

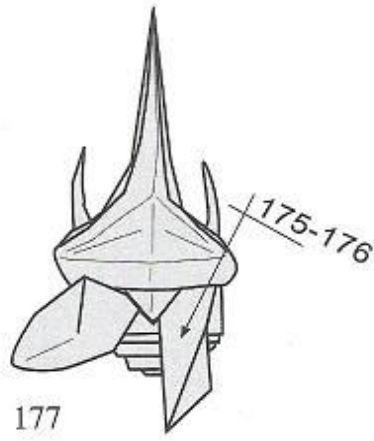

177

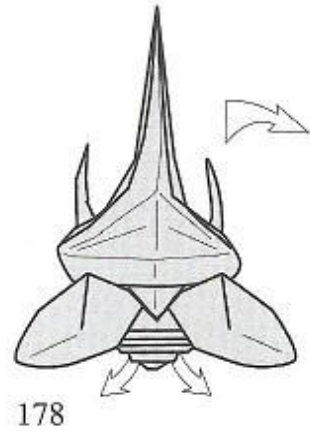

178

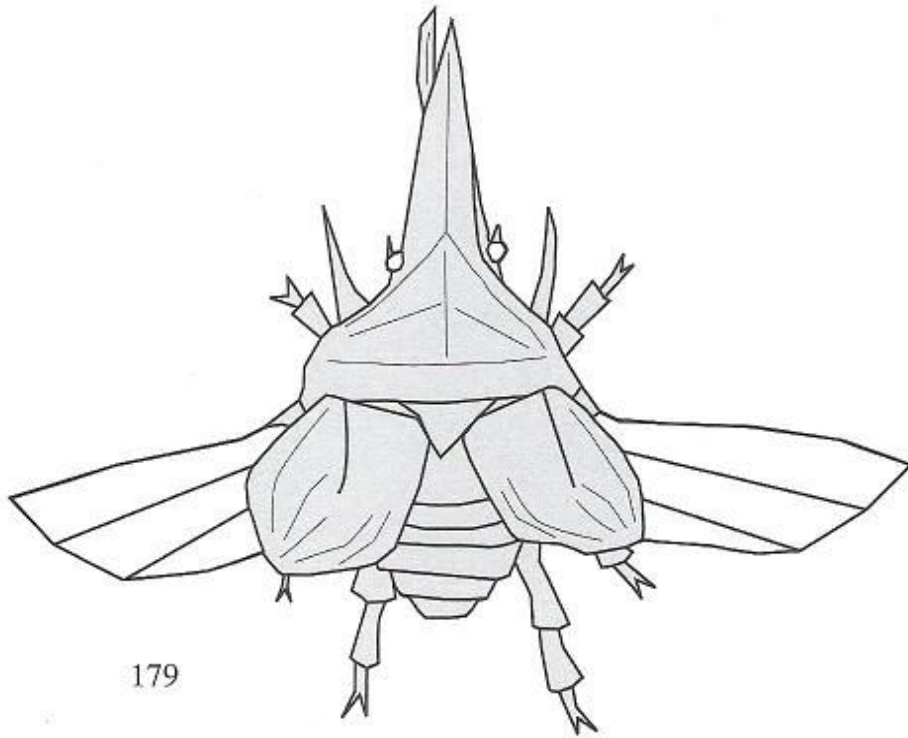

179

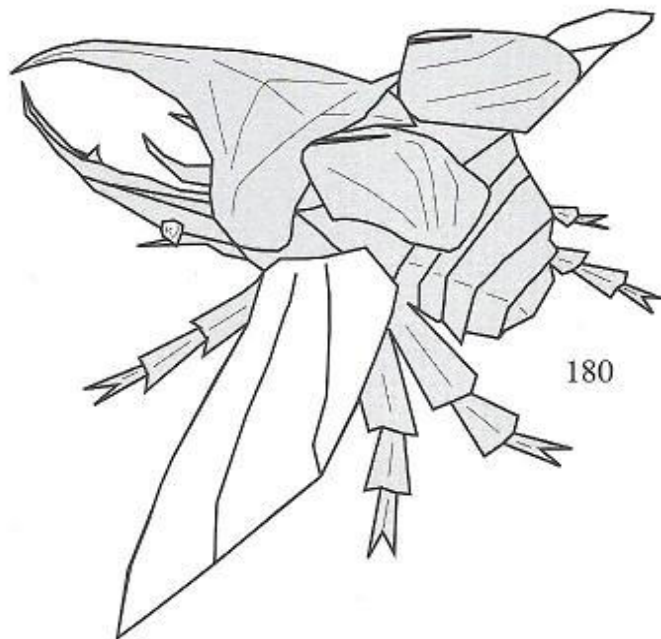

180



Swan swimming

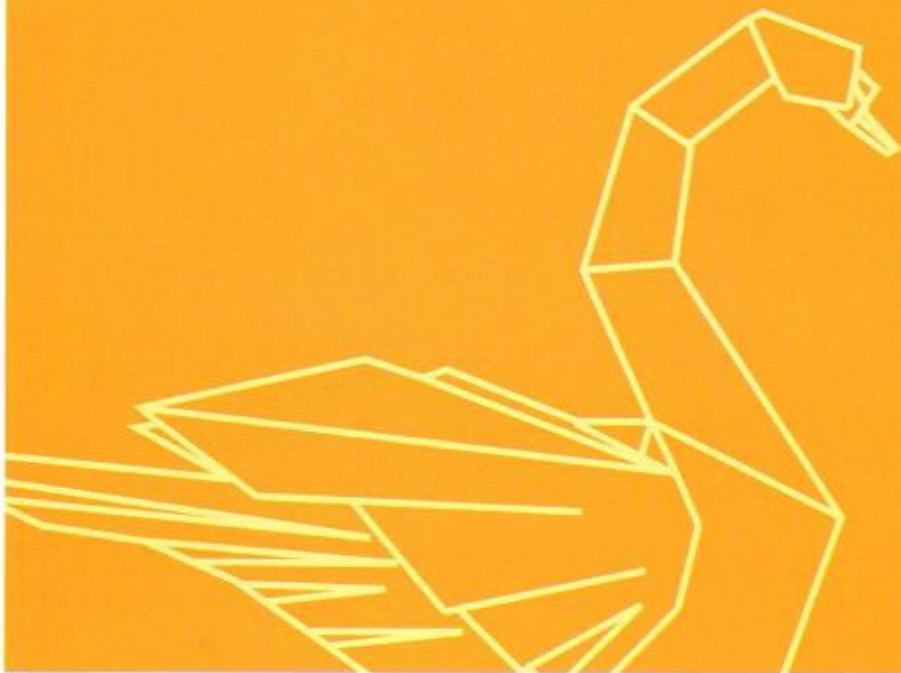



Macaw

Dugong





Narwhal

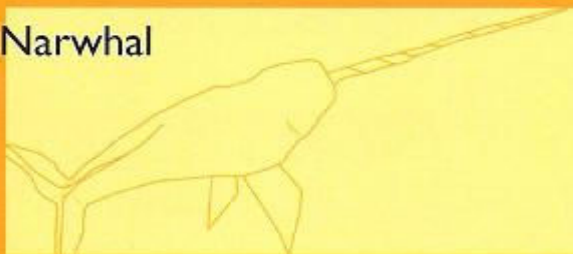

Sea Lion





Black Widow



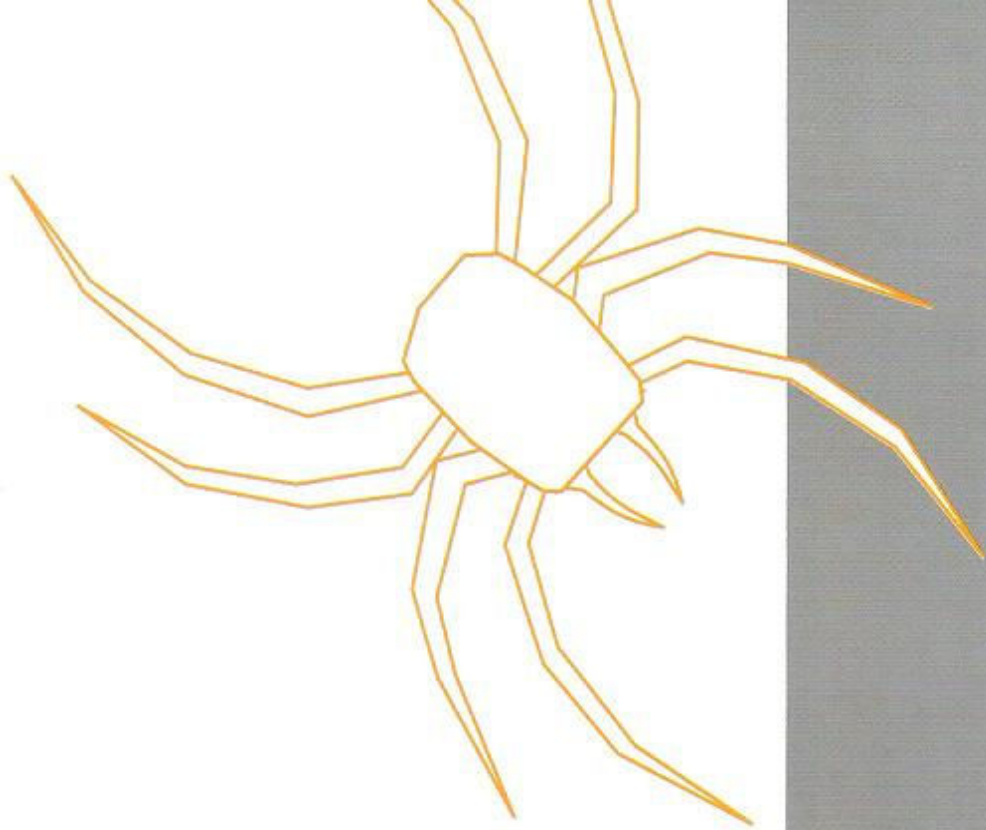

Harvestman (*Phalangium*)

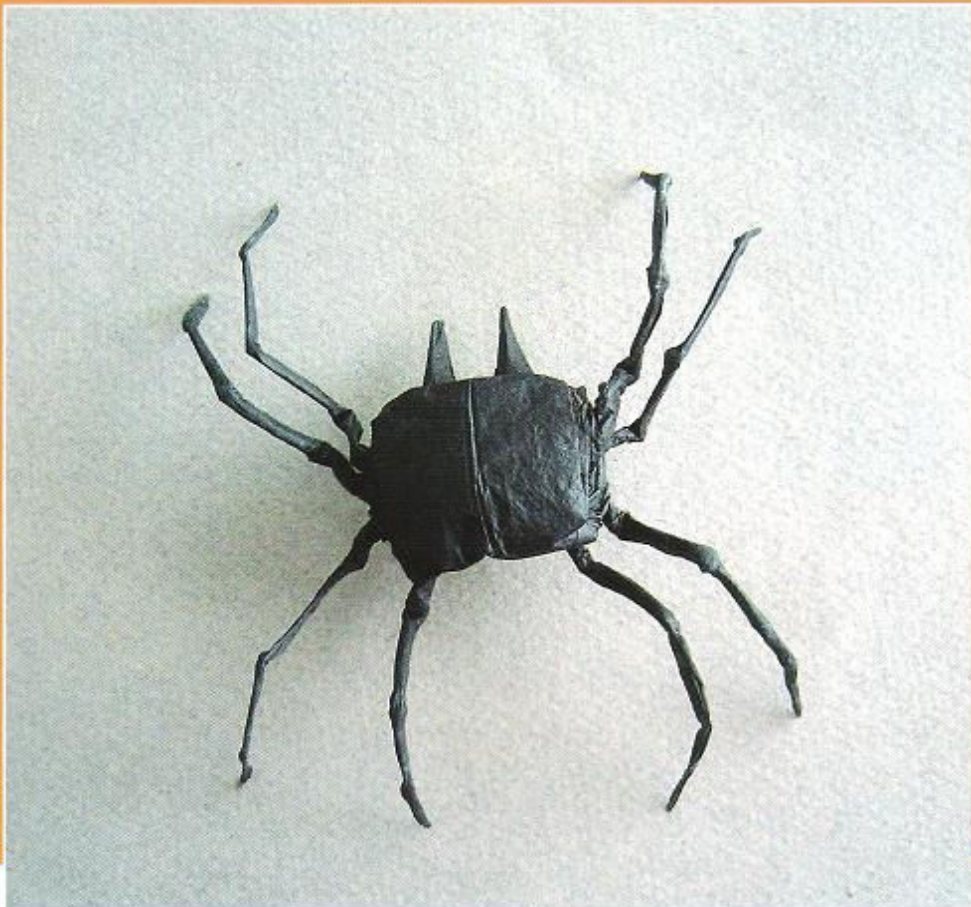



Stingray

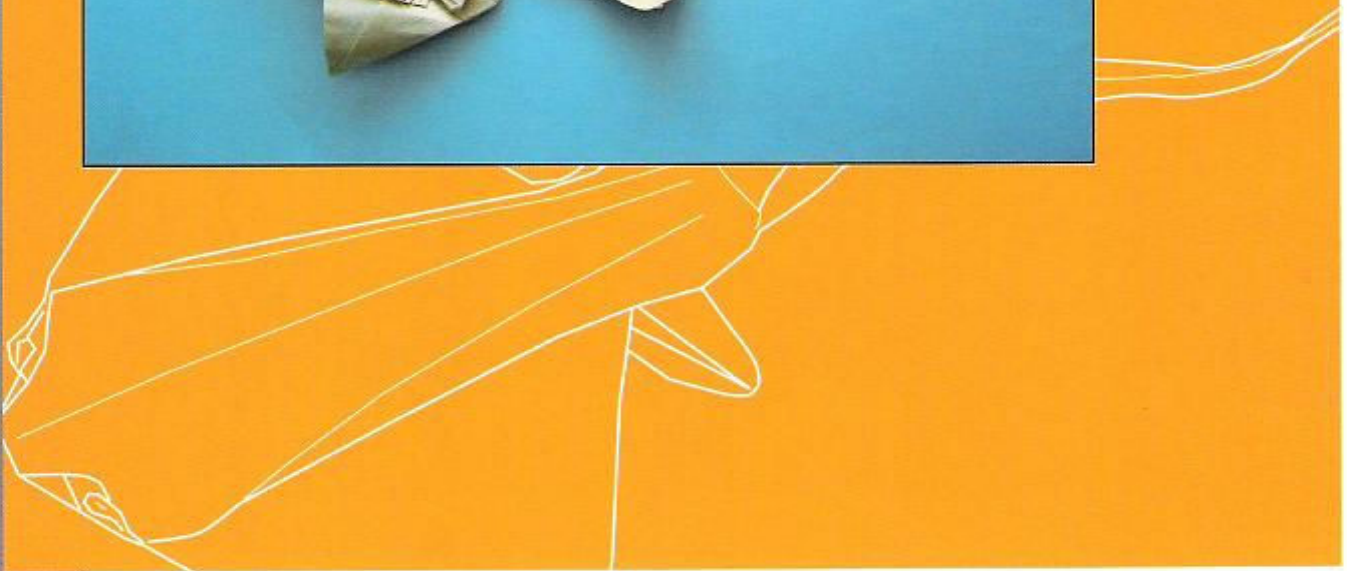
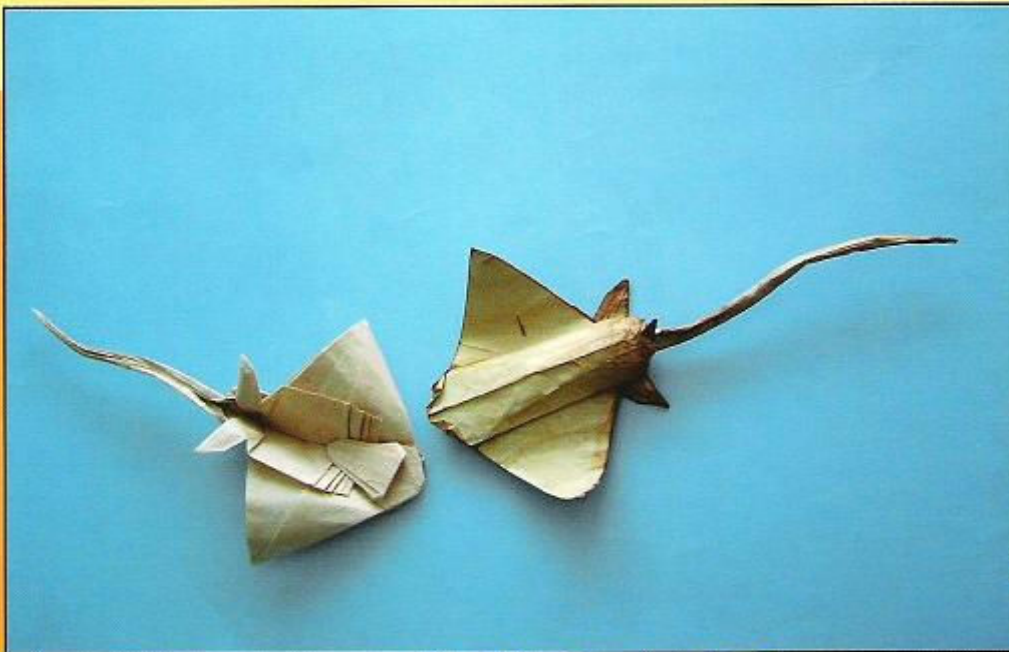

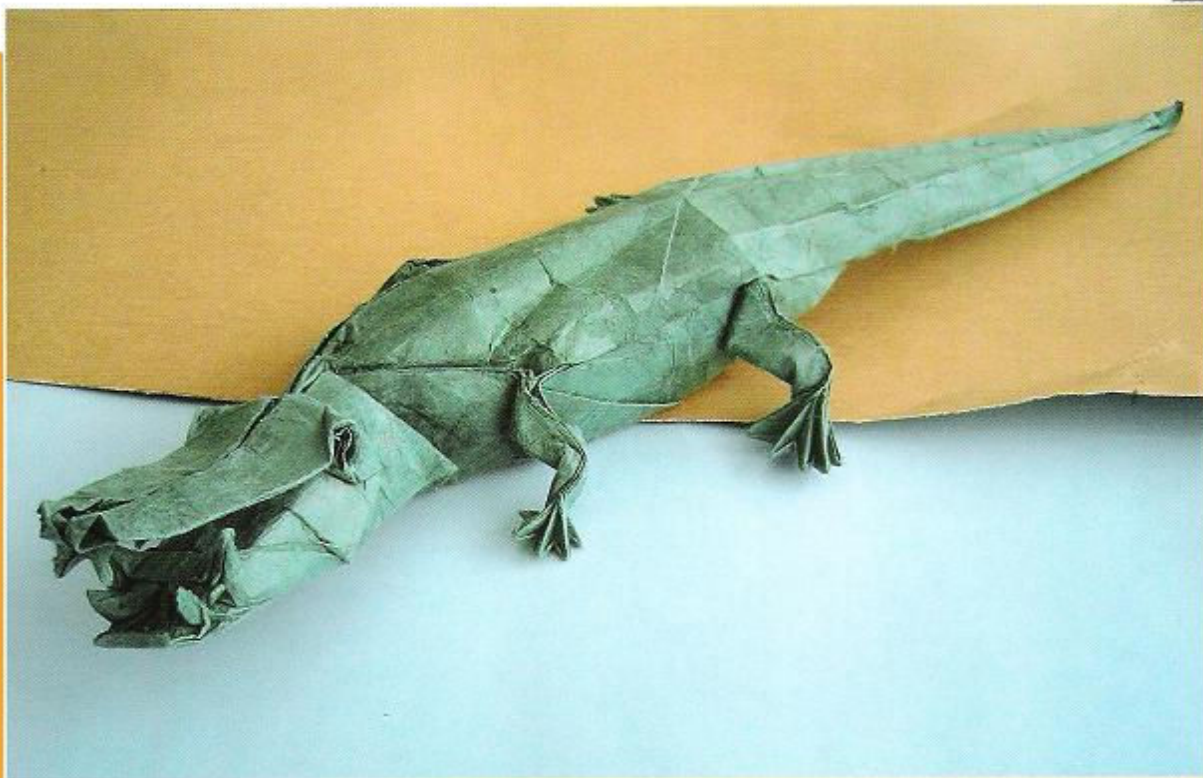

Crocodile

Star

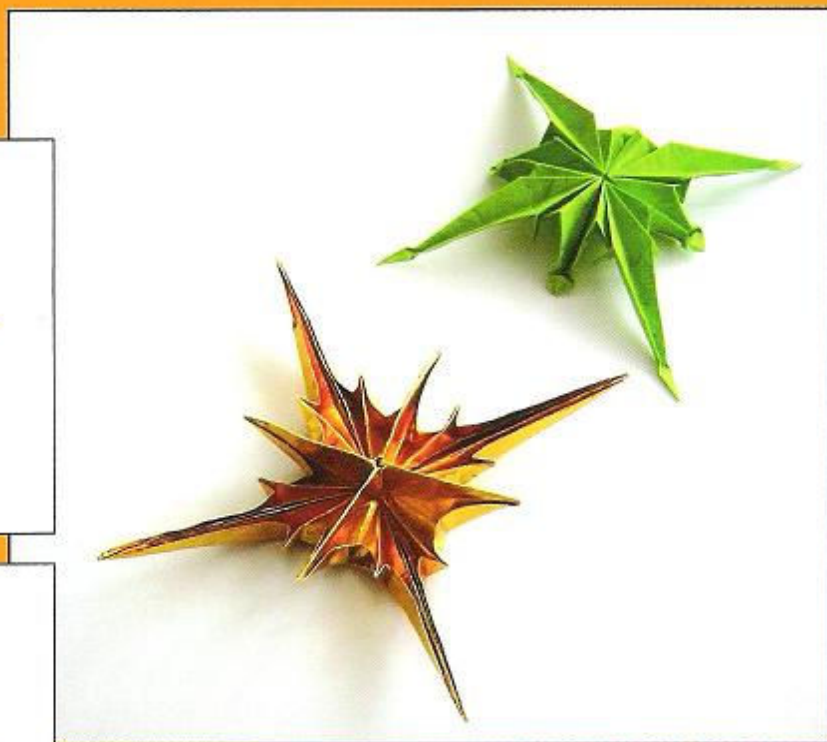

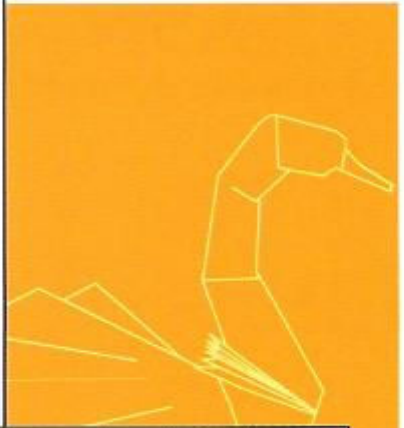

Swan



Walking Stick



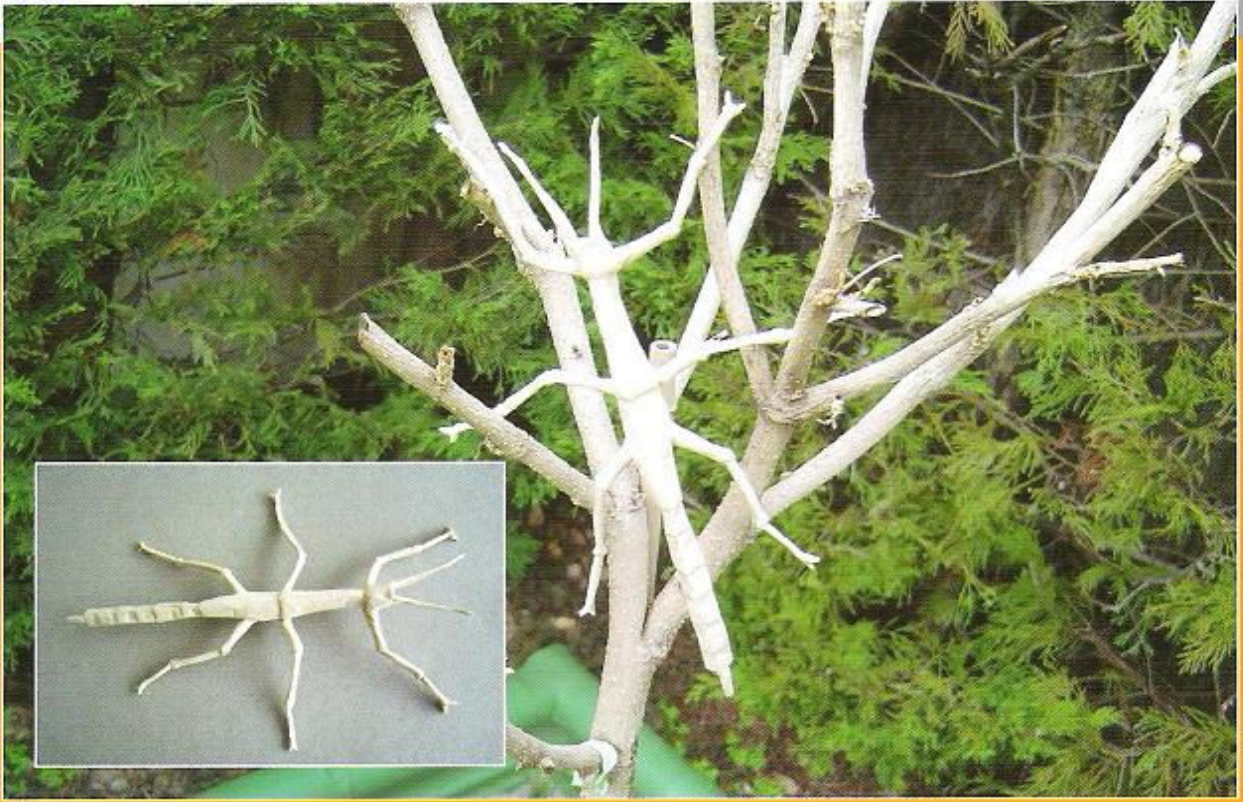

Leaf Mantis

Stick Insect





Black Ant

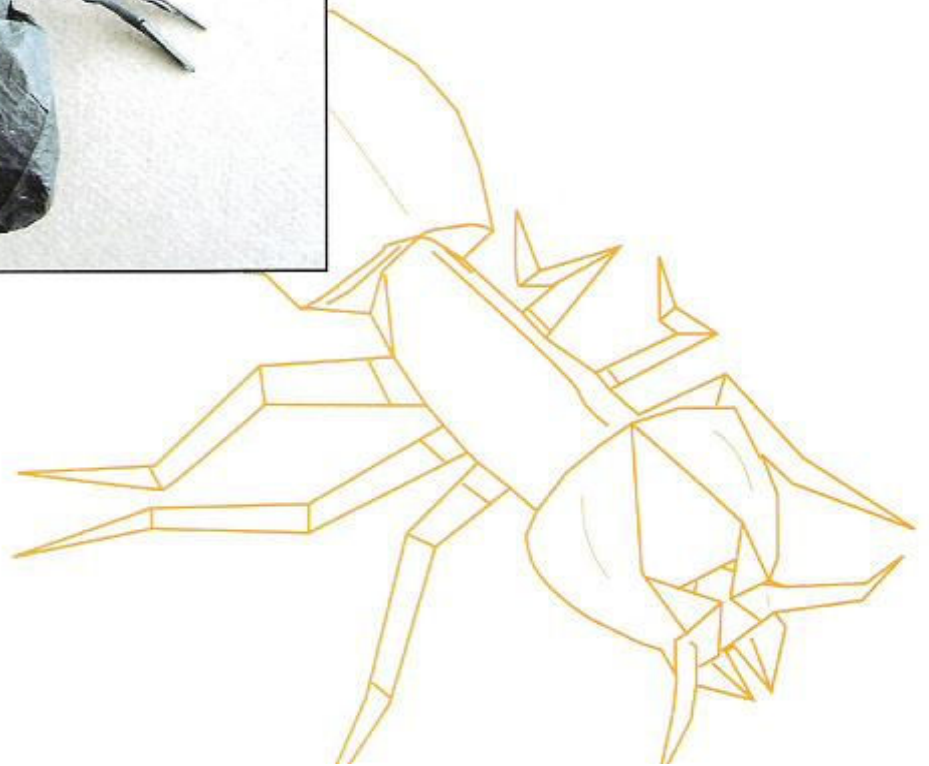
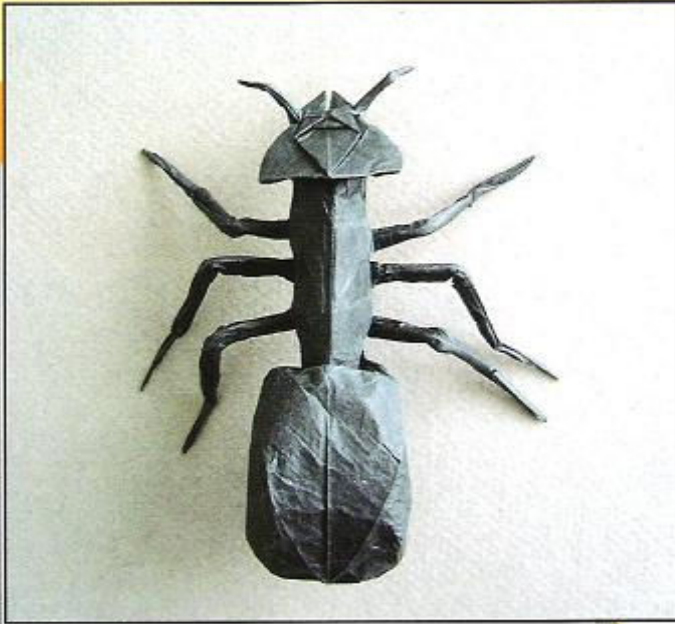



Crayfish

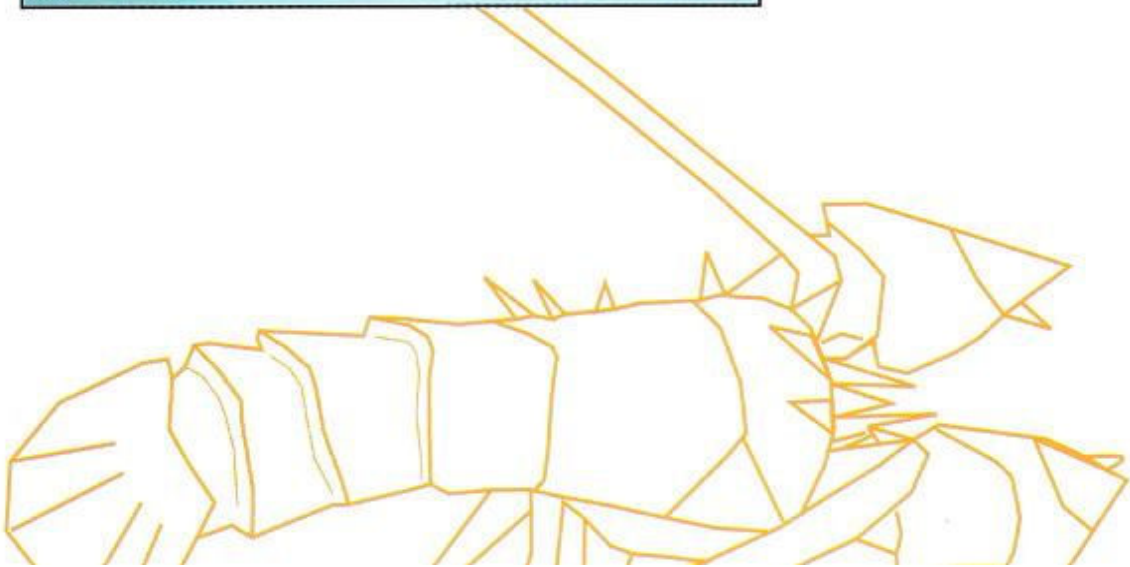

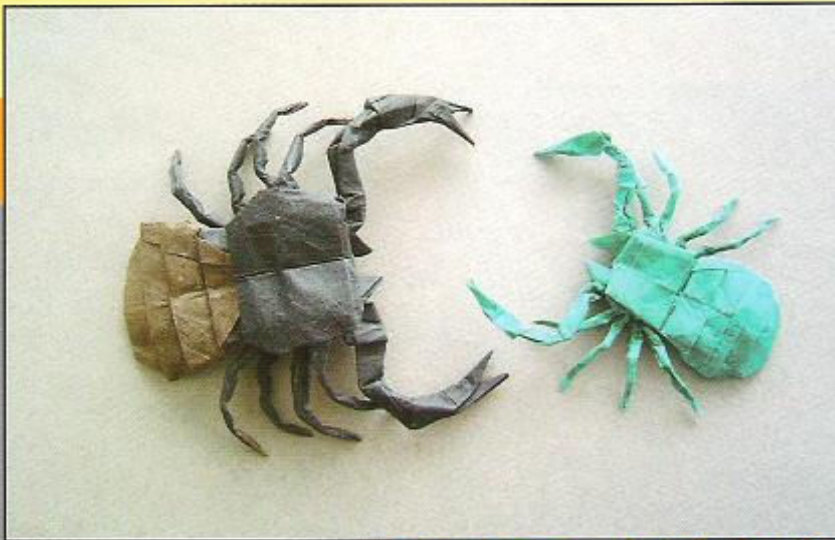

Pseudoscorpion

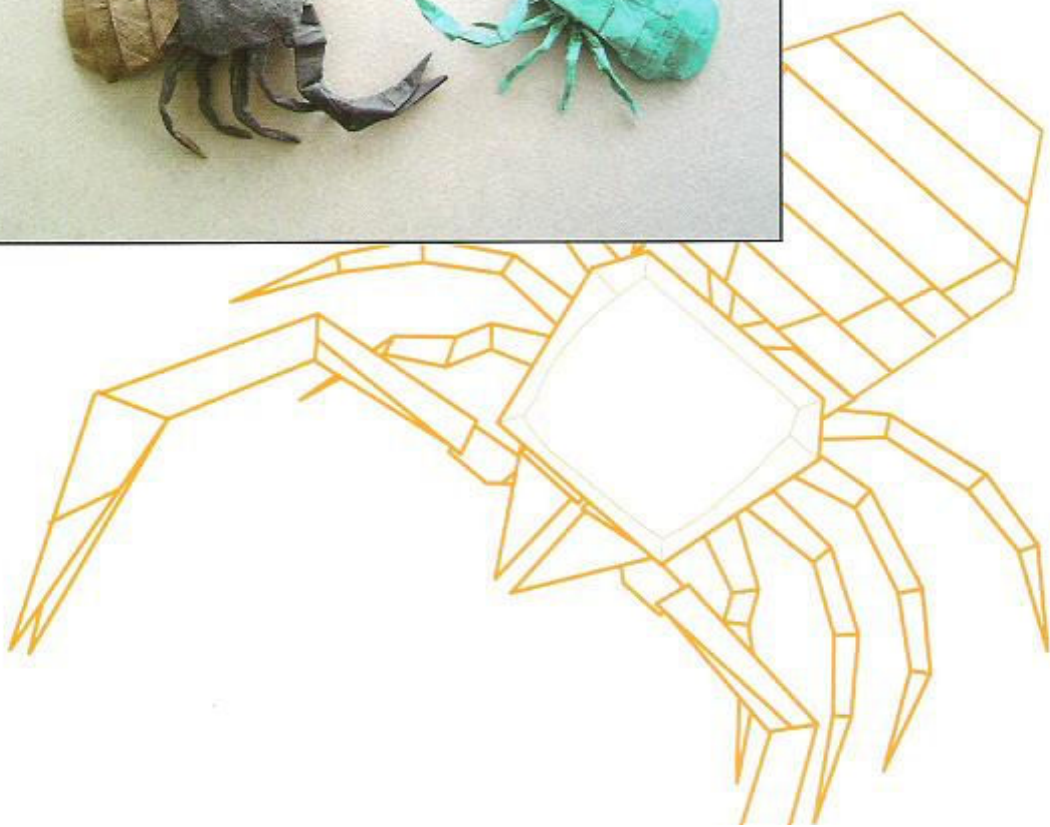



Scorpion (*Buthus*)

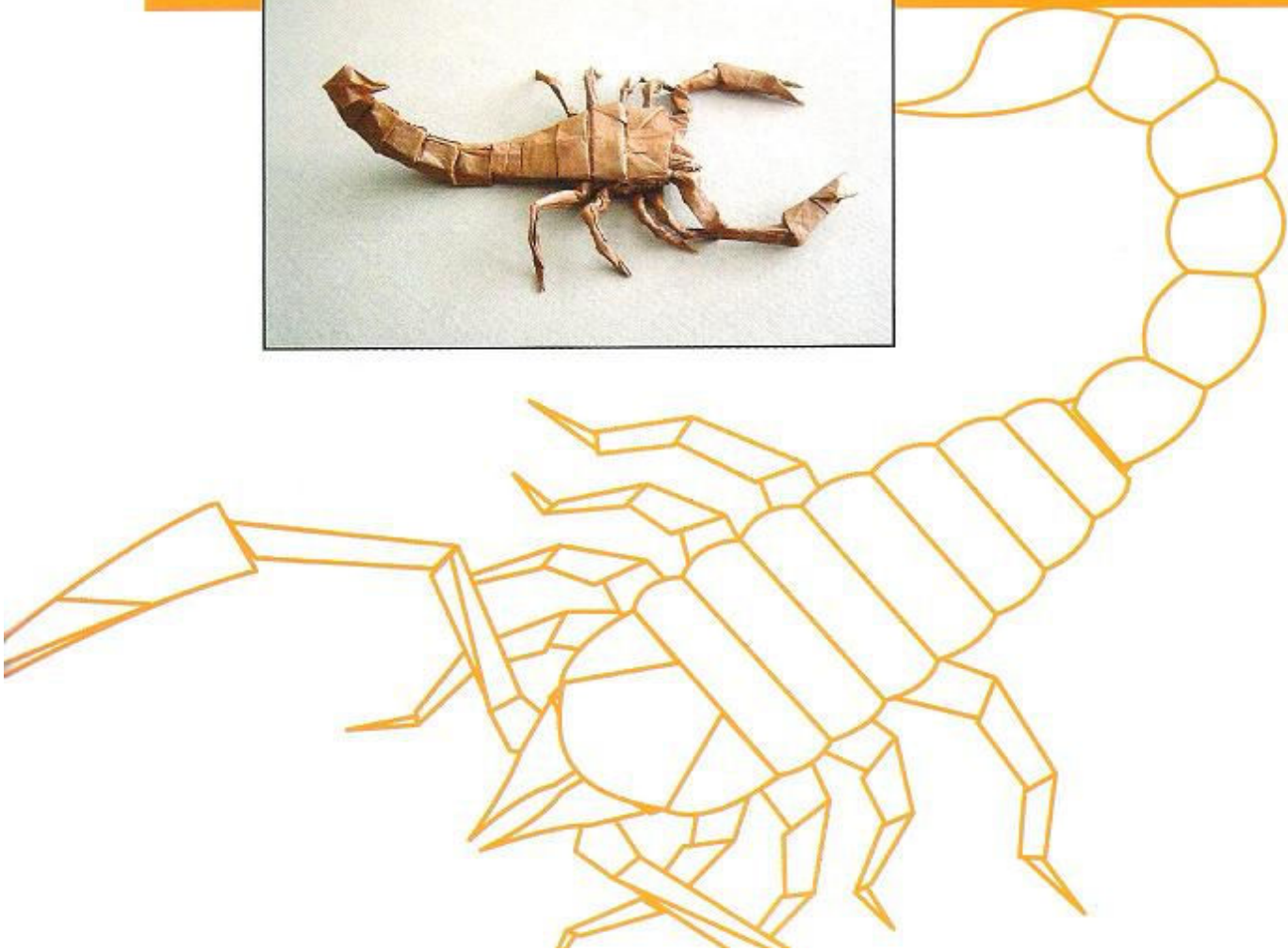
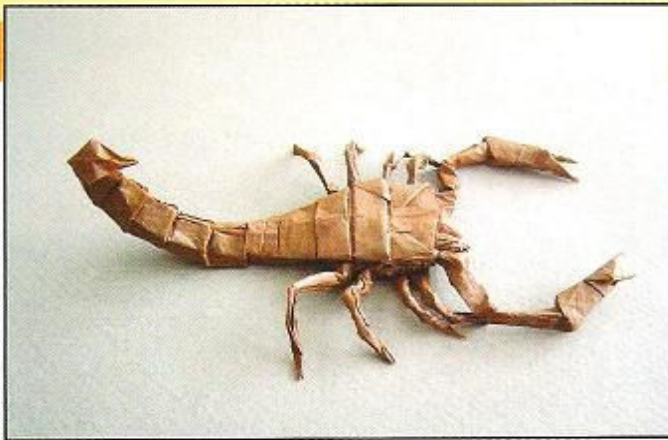



Stag Beetle (*Cyclommatus imperator*)



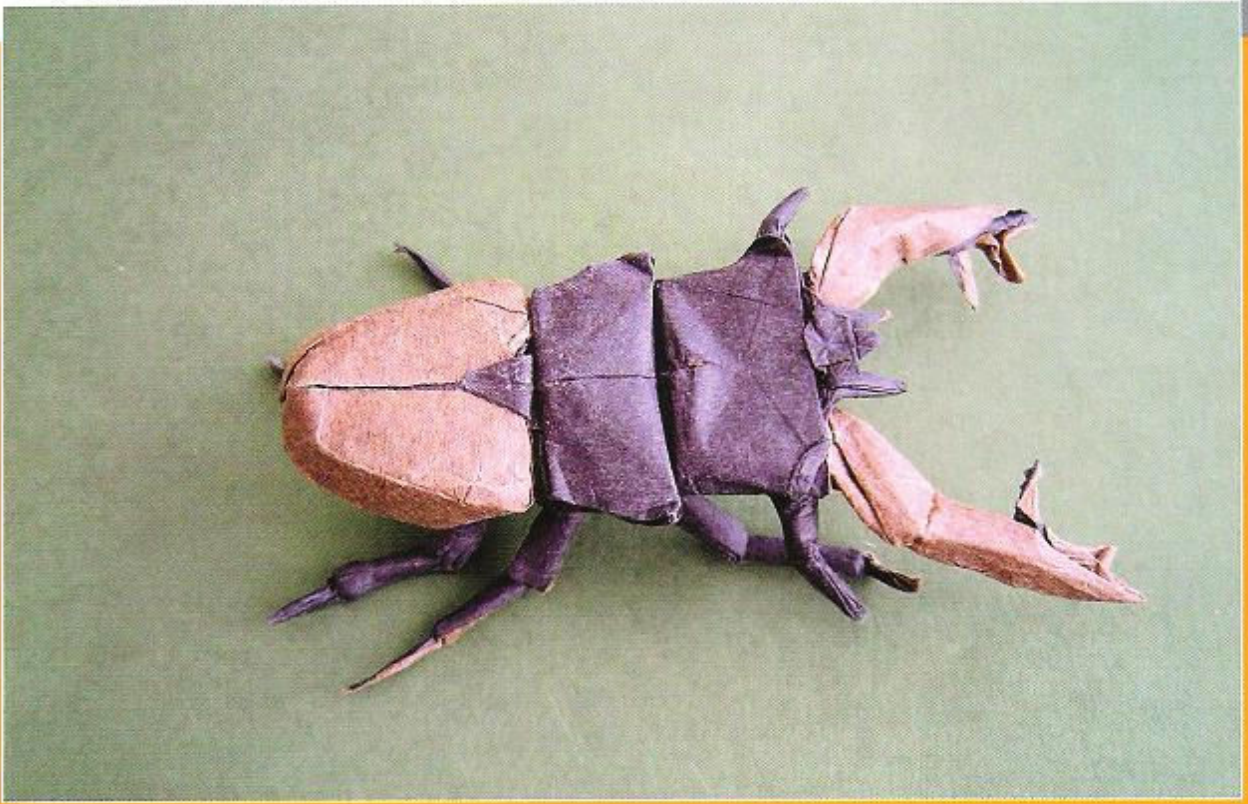

European Stag Beetle
(*Lucanus cervus*)

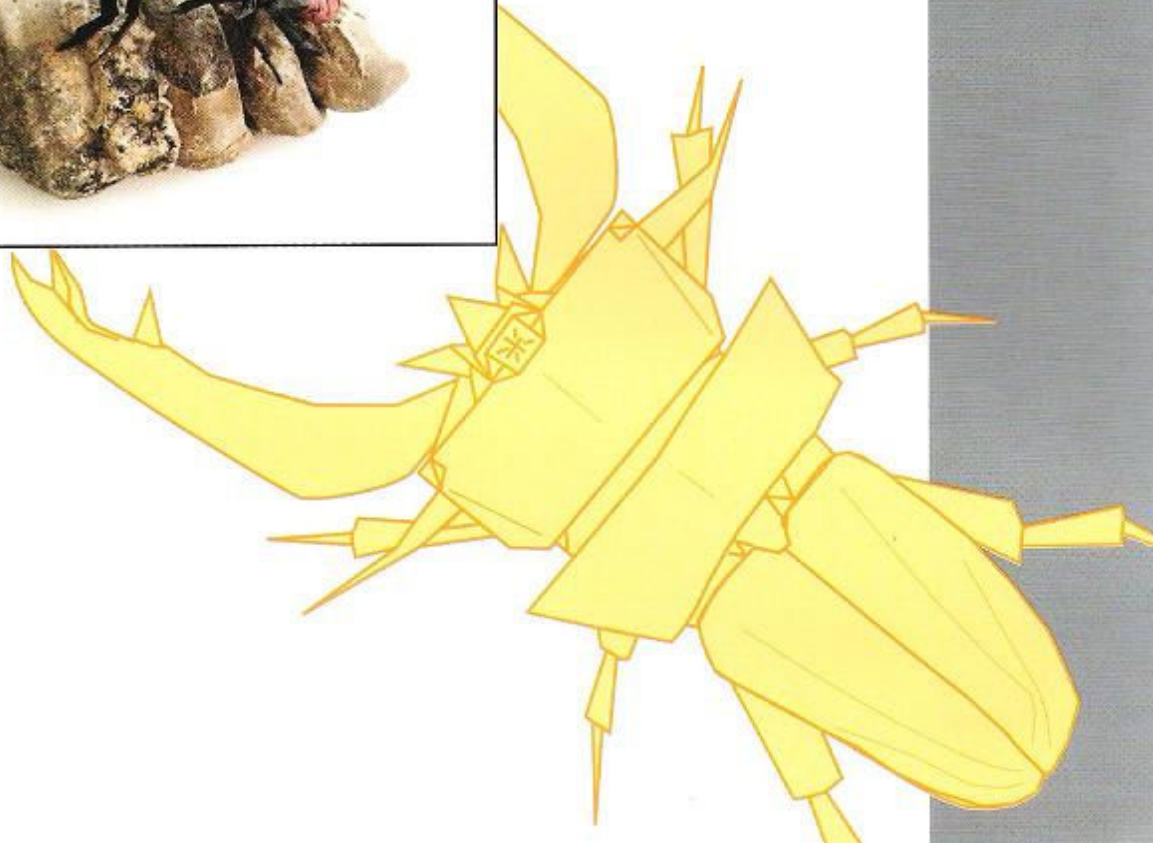



Rhinoceros Beetle flying (*Dynastes neptunus*)

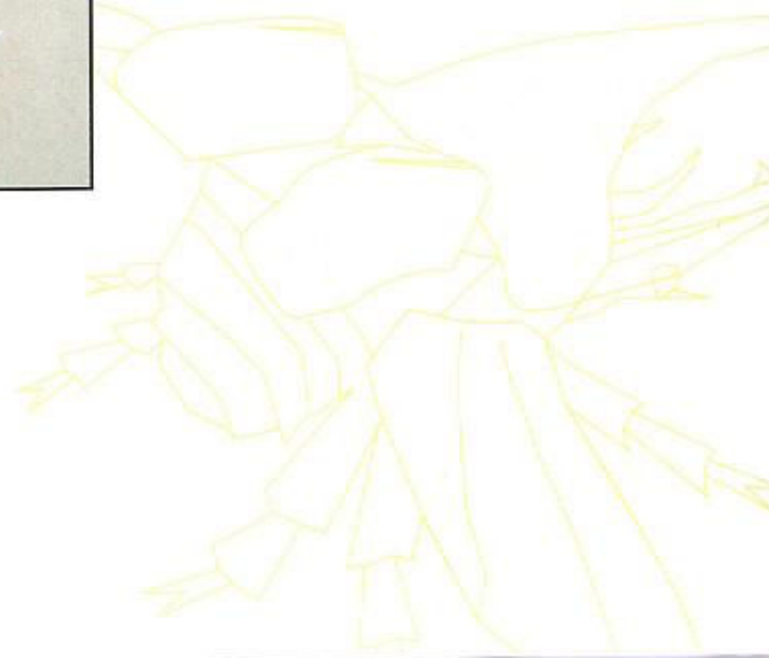
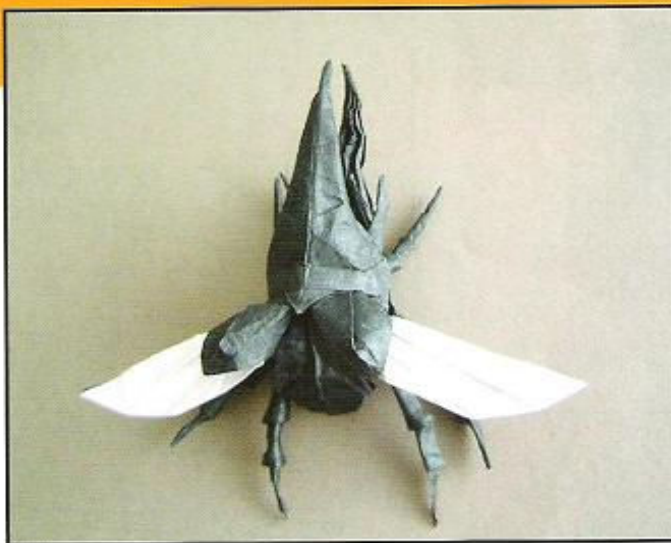

ORIGAMI

Menagerie

Origami enthusiasts will treasure this inventive collection of realistic animal and insect models. Created by a Spanish master of *papiroflexio*, or paperfolding, these intricate figures range in complexity from intermediate to extremely advanced. The 21 patterns come with detailed explanations of folding techniques and amazing finishing touches. The author includes instructions on how to prepare the paper for the figures, some of which use thick wet paper to achieve remarkable effects.

Starting with the simplest and advancing to the most demanding, the models include aquatic life—two kinds of swans, a dugong (sea cow), a narwhal, a sea lion, a stingray, a crayfish, and a crocodile—a macaw, a black widow spider, and an incredible assortment of insects—two types of scorpions and stick insects, a leaf mantis, a black ant, and three varieties of beetles. More than 2,000 illustrations, 35 of them in bold color, offer step-by-step directions.

Dover (2008) English translation of *Imaginando en papel*, originally published in Spanish by Editorial Miguel A. Salvatella, S. A. Barcelona, Spain, 2006. 272pp. 8 $\frac{3}{8}$ x 11. Paperbound.



See every Dover book in print at
www.doverpublications.com

Cover design by Pete Bonahue